

INSTALLATION INSTRUCTIONS FOR LAMINATE FLOORS

MEGALOC TWIN INSTALLATION SYSTEM

EN / REV. 1.9 / 03.26

1. PREPARATION/STORAGE

Acclimatisation

Allow CLASSEN laminate flooring to acclimatise prior to installation. To do this, stack the unopened boxes crosswise for at least 48 hours in the area where they will be installed [1]. Please store the boxes at a distance of at least 30 cm from outside walls, heat sources and air conditioning systems. The temperature should be at least 18 °C (64 °F) and the relative humidity 40–60%.

Inspection of the product

Please check the product for damage and obvious defects prior to installation. Do not install planks that were already damaged prior to installation [2].

It is recommended that you install the floor covering in daylight or good lighting; otherwise, there is a risk that defects will not be detected. In the event of a subsequent complaint, no refund can be provided for planks that are installed despite an obvious defect.

2. SUBFLOOR CONDITION

Old coverings:

Existing old coverings such as carpet, needle felt or PVC floor coverings must be removed completely [3]. The subfloor must be firm, clean [5], level and dry (ready for installation according to DIN 18365, DIN 18202). The moisture content of the subflooring must be checked and must not exceed 1.8 CM-% for cement screed and 0.3 CM-% for anhydrite screed or anhydrite flowing screed [4].

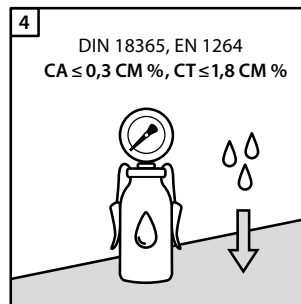
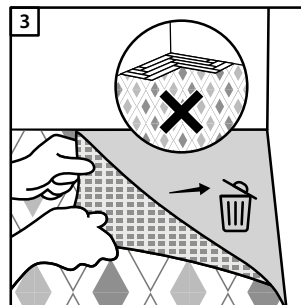
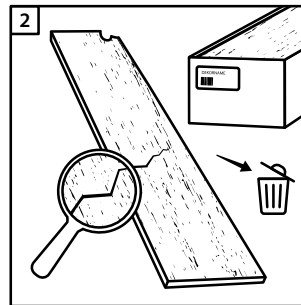
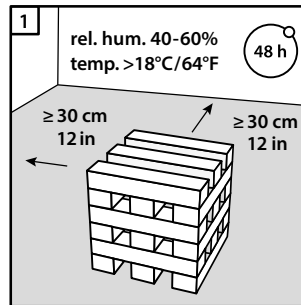

The evenness of the subfloor is of particular importance.

[6] Levelling is required for:

- Height differences of more than 2 mm/m
- Uneven joints between adjacent areas

Mineral Subfloors and Tiles:

For installation on mineral subfloors, always use a vapour barrier with an SD value of at least 75 m (see item 4). For subfloors that are in direct contact with the ground, adequate site-provided damp-proofing must be in place.

Wood Subfloors:

For subfloors made of wood or wood-based materials, ensure that the subfloor is level, vibration-free, dry, free of mould and insect infestation and sufficiently ventilated. The moisture content must not exceed 10%. The use of a PE film as a vapour barrier is not permitted on wooden subsurfaces (to prevent condensation).

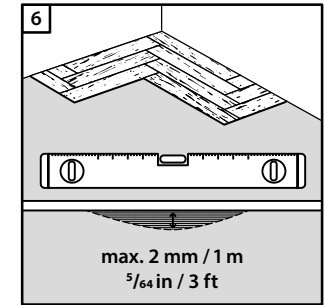
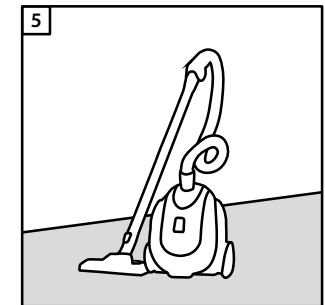

3. INSTALLATION MATERIAL AND TOOLS

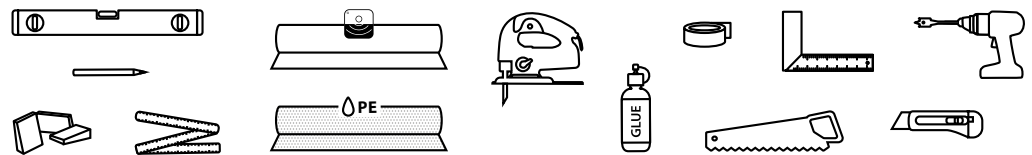

Rev. 1.9 / 11.25

- Spirit level, screeding level
- Vapour barrier, SD value > 75 m (PE film at least 0.2 mm)
- Impact sound underlay max. 3 mm thickness and min. CS value 120 kPa, min. CC value 20 kPa, DL25 min. 100,000 cycles
- Floor/transition profiles at room transitions (if required), end rails
- Folding rule, tape measure
- Angle bracket, bevel
- Carpet knife
- Pencil or felt pen
- 10 mm spacer wedges
- 50 mm wide moisture resistant adhesive tape
- Mitre saw, cross-cut saw
- D3 white glue.
- Optional: drill and drill bit, hacksaw, handsaw, laminate cutter

4. INSTALLATION UNDERLAYS

Installation underlays significantly affect the durability of the floor covering [7].

1. Vapour barrier
2. Impact sound underlay
3. Floor covering

Vapour barrier: PE film is essential as a vapour barrier on mineral subfloors to prevent damage caused by rising damp. This is achieved, for example, by a 0.2 mm thick polyethylene vapour barrier with an SD value of 75 m. The edges of the vapour barrier should overlap by approximately 20 cm and then be sealed with moisture-resistant tape. Allow the vapour barrier to go at least 2 cm up the wall and then cut it after fitting the skirting boards [8].

Impact sound underlay: The impact sound underlay affects sound transmission and thermal conductivity in particular, as well as the service life of the floor covering. The impact sound underlay must not exceed a maximum thickness of 3 mm. We recommend compliance with the elevated requirements of the EPLF (Association of European Producers of Laminate Flooring) with a minimum compressive strength (CS value) of 120 kPa (= 12 t/m²i).

In addition, the impact sound underlay should have a CC value of 20 kPa and a minimum DL25 value of 100,000 cycles [9a]

Requirement	Value	Unit
DL25	100.000	Cycles
CS	120	kPa at 0,5 mm compression
CC	20	kPa at 0,5 mm compression

ATTENTION! Do not use any additional impact sound insulation with products that have an integrated impact sound underlay [9b].

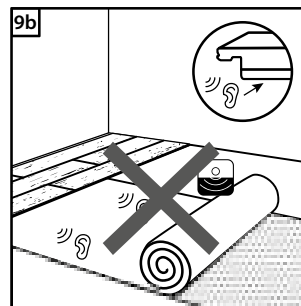
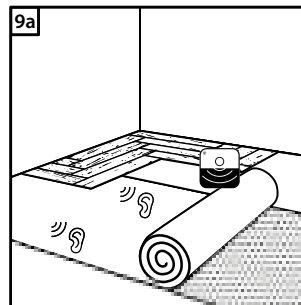
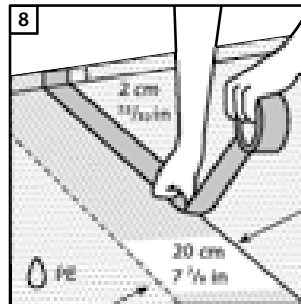
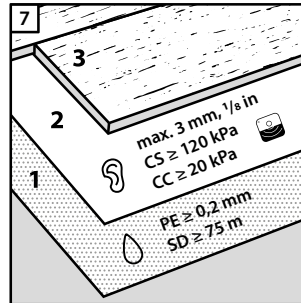

5. INSTALLATION OVER UNDERFLOOR HEATING

The floor covering can be installed without problems over underfloor heating systems (hot water-based and electric) provided these are permanently embedded in the screed and the surface temperature does not exceed 29 °C [10].

ATTENTION! Combining the flooring with electric heating foils laid/installed loosely on the screed is not permitted [11]. When installing over underfloor heating systems, the total thermal resistance of the floor covering and impact sound insulation must not exceed an R-value of 0.15 m²K/W. Please refer to the technical data sheets for the R-value of the floor covering. Prior to installation, the heating installer must conduct and document the prescribed initial and drying heat-up (further technical information can be found here: "Interface coordination for heated floor constructions" at www.flaechenheizung.de).

For underfloor cooling systems, the R-value (thermal resistance) must be less than 0.10 m²K/W and the formation of condensation must be prevented by a suitable control / automatic shut-off system.

A permanently stable installation requires a balanced indoor climate [12]. The optimum room climate for installing and using the floor covering is a relative humidity of 40-60% and a room temperature of 18-24 °C.

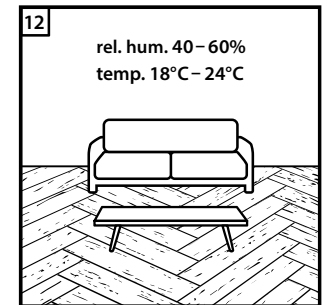
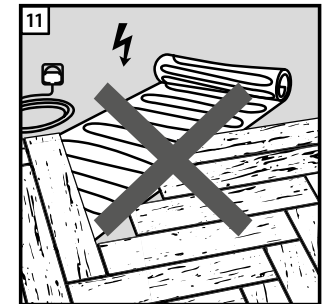
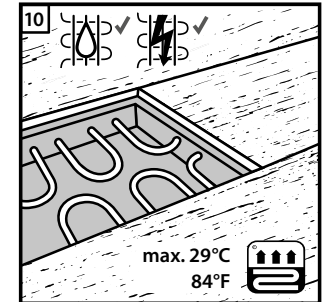

6. INSTALLATION

[12] The floor covering is intended for use in dry interiors under residential conditions, meaning a room temperature of 18-24 °C and a relative humidity of 40-60%.

The flooring is not suitable for outdoor use or unheated rooms (e.g., garden sheds, conservatories) or for areas exposed to excessive moisture, such as wetrooms, saunas or similar environments [14]. The floor covering must be protected against intense and direct sunlight to prevent damage.

Attention! [15] Floating floors must never be firmly attached to the subfloor!

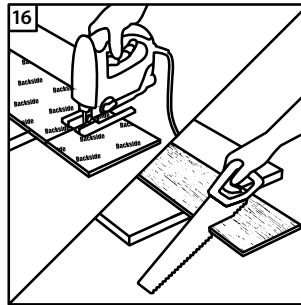
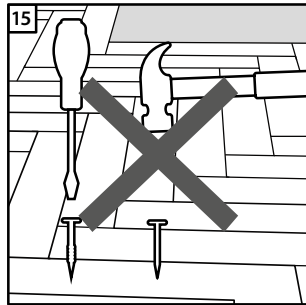
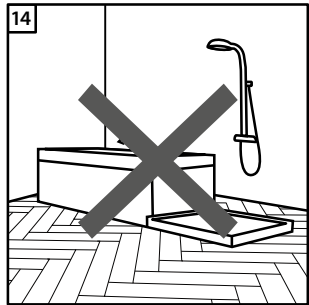

To prevent tears at the cut edge, ensure that the panels are aligned correctly when cutting:

- When cutting mechanically (e.g., with a jigsaw or circular saw), the elements should be laid with the decorative side facing downwards, as the saw teeth usually cut upwards, thereby causing any tearing damage to be on the reverse side.
- When cutting manually (e.g., with a laminate cutter or hand saw), it is advisable to work on the panels with the decorative side facing upwards to ensure a clean cut edge on the top side [16].

Movement joints of 10 mm must be maintained at transitions to other rooms and to all fixed components. Additional expansion joints must be provided for room dimensions greater than 8 m [17].

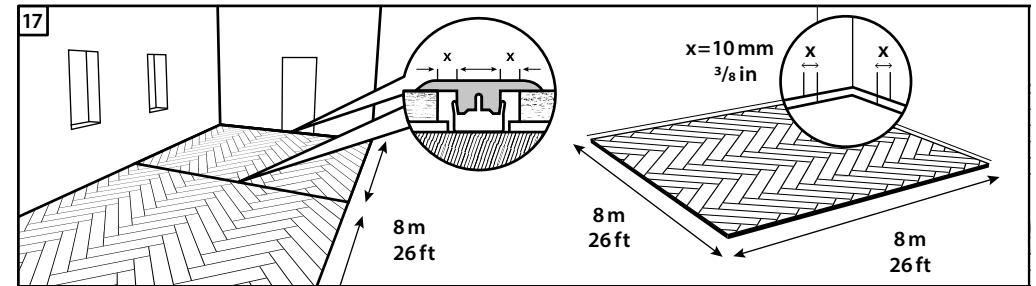

Additional expansion joints of 10 mm are to be provided at:

- All ascending components, such as heating pipes
- Fixed structural boundaries
- Around fixed objects, such as kitchen units, ovens and doorsteps
- Between individual rooms such as thresholds
- At the transition between two different floor coverings
- In rooms with complex floor plans
- Expansion joints existing on site are to be incorporated in the surface covering

The floor around wood-burning stoves must be protected from falling embers by a spark protection plate. The spark protection must extend at least 50 cm to the front and at least 30 cm on each side of the combustion chamber. To prevent the laminate floor from being firmly fixed in place by a fireplace, the spark protection panel must be separated from the rest of the floor surface by a 10 mm movement joint.

Please ensure that all applicable local legal requirements and building regulations are complied with.

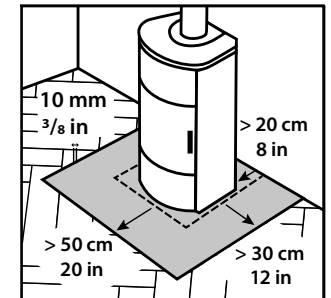

7. STEP-BY-STEP INSTALLATION

First, install the vapour barrier (see item 3) and the impact sound insulation underlay prior to installing the first element. Ensure the individual strips of the impact sound insulation underlay are laid edge to edge without overlapping.

TIP! Use adhesive tape to attach the butt edges of the impact sound insulation together. This will prevent the individual strips from slipping.

Before starting the installation, clean and measure the width of the room.

Selecting the installation pattern:

There are two pattern variants to choose from:

- **V1 – 45°-herringbone pattern**, symmetrical variant, laying starts from the centre of the room
- **V2 – 90°-herringbone pattern**, asymmetrical variant, laying starts from one corner of the room

You must choose one of the two installation patterns **before starting** the installation work. Once begun, you cannot change the laying direction or pattern (between V1 and V2) [13].

General installation instructions (for both variants):

- Before joining two panels, make sure that all profile areas are **free of contamination**. Chips, wood debris or other foreign matter must be completely removed to ensure a proper connection.
- **No special tools** are required for laying. Using a hammer or forcing the elements into place can damage the profile connection and should be avoided.

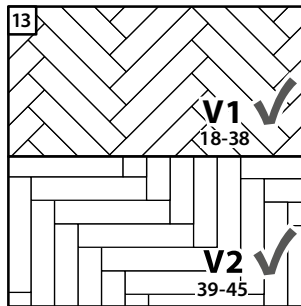

- After locking two panels together, **carefully check the edge symmetry along the V-groove**. There must be no visible or noticeable misalignments or differences in height. Precise alignment from the very first panel is crucial in order to avoid dimensional deviations as you continue and to ensure uniform, high-quality installation. Take particular care to ensure that the planks are laid at a **right angle (90°)**. This must be precisely maintained from the outset and **checked regularly** during installation, as even the smallest deviations can affect the overall appearance of the herringbone structure.

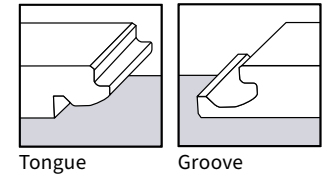

INSTALLATION PATTERN VARIANT V1

45° herringbone pattern starting from the centre line of the room

For an even and centred installation pattern, proceed as follows [18]:

1. Divide the width of the room into two equal halves and mark the centre at each end of the room.
2. On the wall from which you want to begin the installation, move 4.63 cm to the right of this centre point and mark this new point.
3. Repeat this process on the opposite wall.
4. Connect the two points. This serves as a precise reference line for the installation.

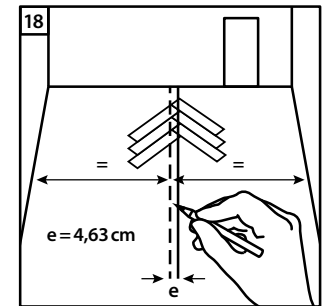

Start the installation with the starting triangle (“centre herringbone”) [19–25]:

- Place one plank in front of you with the groove on the long side facing you – this is your **guide plank**.
- Insert the short side of the first plank (**plank 1**) into the groove of the guide plank so that the groove on the long side of this plank also faces you.
- Now take another plank (**plank 2**) and insert the tongue of the long side into the groove of the guide plank at an angle of approx. 30°. Carefully slide the plank until it is flush with plank 1, and then snap it down so that it locks in place.
- Check that planks 1 and 2 are positioned at a precise 90° angle to each other. Make any slight adjustments needed.
- Now lay the next plank (**plank 3**) by inserting the tongue of the long side into the groove of plank 1 at an angle of 30°. Carefully slide the plank until it is flush with plank 2 and snap it down to lock it in place.
- Continue adding planks at 90° angles in this manner, alternating between the left and right sides of your triangle.
- Once you have laid 3 planks on each side you can remove the guide plank. To do this, carefully tilt it at a 45° angle to disengage the connection between planks 1 and 2.
- Now carefully slide the starting triangle to the wall and align it precisely with the previously marked reference line. Be sure to maintain a distance of at least 10 mm from the wall as an expansion joint. The point of the starting triangle and the 90° angle between the adjacent planks (planks 5 and 6) must run exactly along the reference line. The result is called the centre section or centre herringbone.

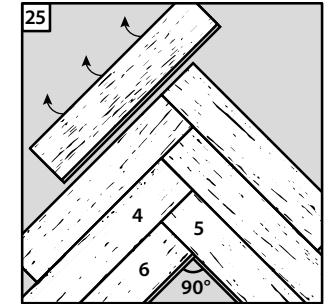
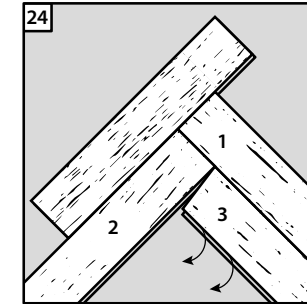
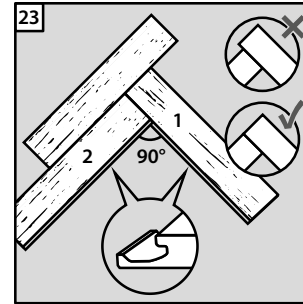
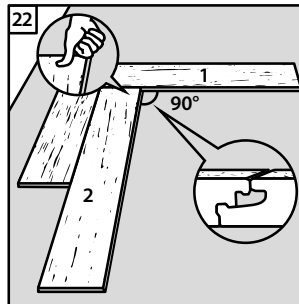
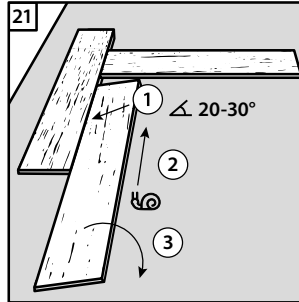
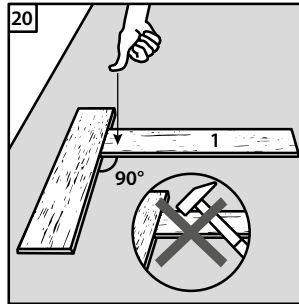
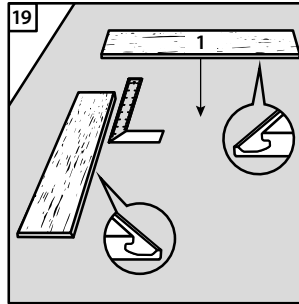

Important! Take special care to ensure that all elements are positioned at exactly 90° to each other. None of the joints should have moved apart after moving the planks. If they have it will be necessary to adjust or reinstall the individual planks. Since the exact positioning of this centre section affects all subsequent installation steps, it is vital to pay special attention to its alignment.

Adding to the centre herringbone [26, 27]:

- Once all the connections of the centre herringbone are tight and correctly angled, the pattern can be extended on both sides as shown to form a symmetrical herringbone “W” until no more complete panels can be used. Refer to the installation diagram for the exact sequence for adding to the centre section.
- The “W” pattern is continued until no more complete panels can be used. Make sure that the centre herringbone remains precisely aligned with the reference line you drew earlier to ensure a uniform and harmonious installation pattern.
- Regularly check the pattern for exact symmetry, joint alignment and right angles.
- Avoid installing the “W” pattern asymmetrically by only installing a single herringbone, as this can lead to gradual angular deviations and joint openings [28, 29].

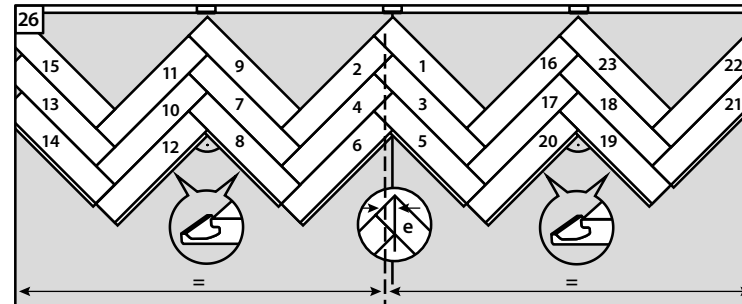

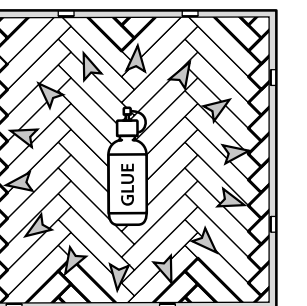
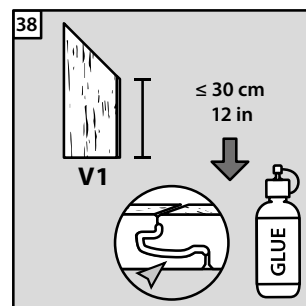
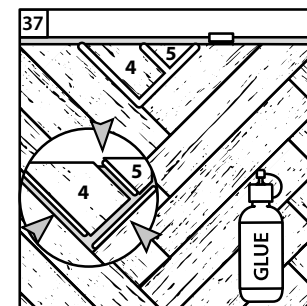
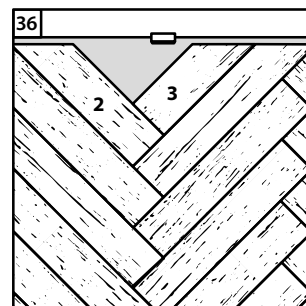
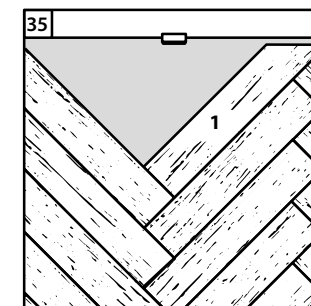
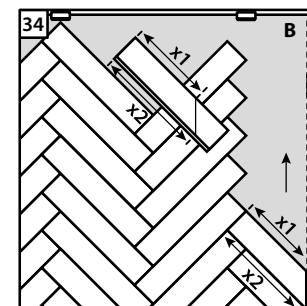
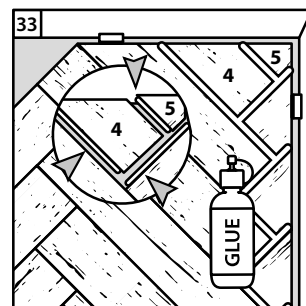
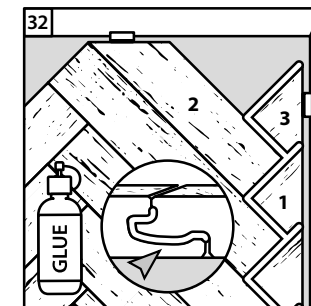
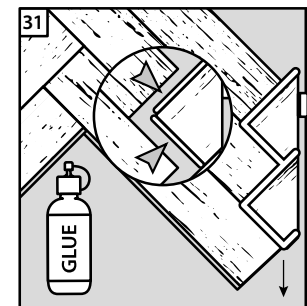
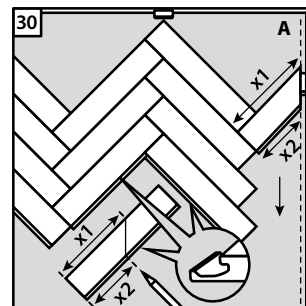
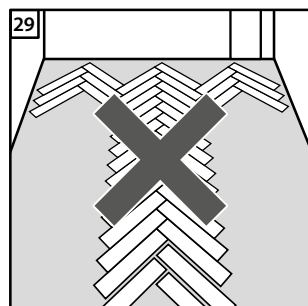
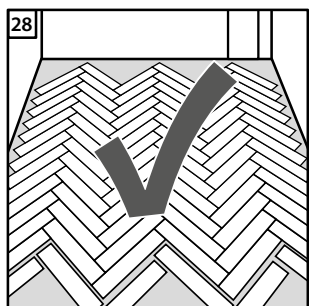
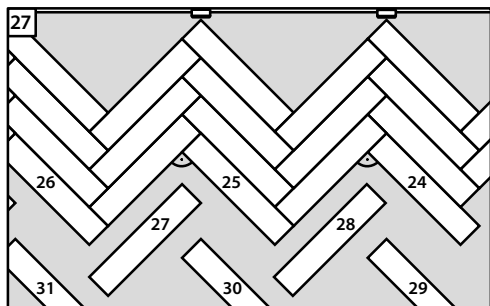

Trim and lay edge planks [30-38]:

- Cut the edge planks at a precise 45° angle using a cross-cut saw or mitre box.
- Maintain the expansion joints of at least 10 mm at all walls.
- Offcuts and triangular remnants with an edge length of less than 15 cm are glued together using wood glue (white glue D3).
- If using glue, make sure that any excess is removed immediately and completely with a damp cloth in order to preserve the long-term surface appearance.
- Clamp the cut elements together until the glue has completely hardened in order to ensure a stable connection.

Important! Complete planks are generally laid without glue. Glue is only applied to connect individual panels and does not affect the fundamentally floating installation of the overall surface.

Final inspection:

- Regularly check the pattern for exact symmetry, joint alignment and right angles.

INSTALLATION PATTERN VARIANT V2

90° herringbone pattern starting from a corner of the room [13, 39-45]

Start of installation:

- Start by placing a guide plank in front of where the starting triangle (centre herringbone) is to be formed.
- Begin the starting triangle as for the 45° pattern by laying three planks at a time at a 90° angle, alternating between the left and right sides.
- Remove the guide plank after laying the sixth plank. Carefully tilt it at a 45° angle to disengage the connection to planks 1 and 2.
- Then carefully slide the starting triangle into the left-hand corner of the room and align it precisely. Be sure to maintain a uniform distance of at least 10 mm from the wall to allow for the necessary expansion joint.
- Check that all elements are positioned at exactly 90° to each other and that no joints are open.

Continuing installation:

- After alignment, continue laying planks on both sides of the centre section following the established pattern.
- With this pattern variant, the plank sections are cut and adjusted at a 90° angle.
- Please note that sections shorter than 30 cm or narrower than 13 cm must be glued together using a suitable wood glue (D3 white glue).
- Glue the cut elements immediately after aligning the centre section and clamp them together until the glue has completely hardened.
- Regularly check the joint formation and the angle to ensure a uniform and high-quality installation pattern.

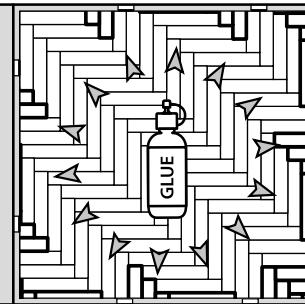
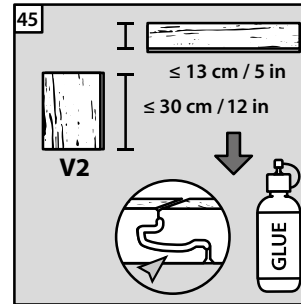
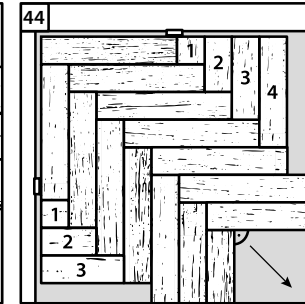
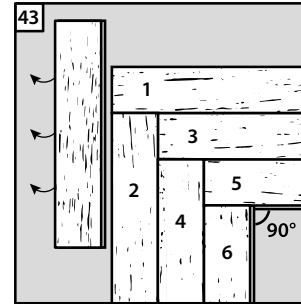
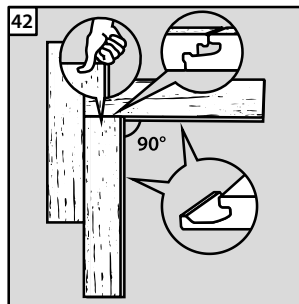
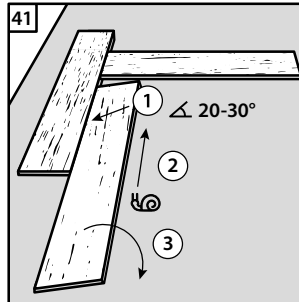
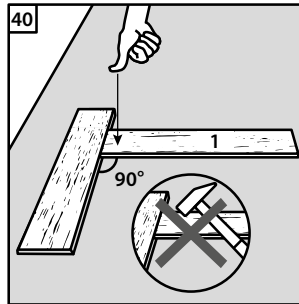
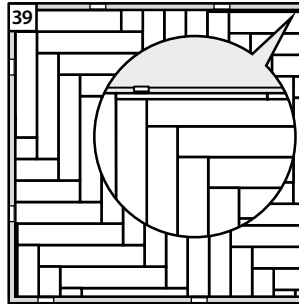

Tip: Working in tight spaces [46]

When working in tight spaces, proceed as follows:

1. Place the element:
Set the element in place on its long side at an angle of approximately 30° and then lower it to around 10°.
2. Insert a shim:
Slide a shim under the long side of the element that has already been laid, close to the point where the top edge of the new element will click into place.
The shim should lift the long side by about 3–5 mm to make it easier to lock the top side.
3. Engage the top side end and remove the wedge:
Lock the new element in place by lowering it the remaining 10°. While doing so, press lightly on the edge with your thumb until the profile clicks into place and there is no longer any height offset.
Then remove the shim and install the next element the same way.

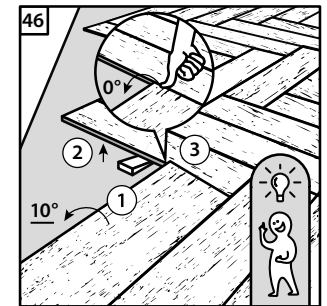

ATTENTION! [47, 48] There must be a 10 mm expansion joint with respect to pipes and any other vertical objects on site. When installing planks around pipelines, cut the holes approximately 20 mm larger than the diameter of the pipe. Then cut through the centre of the holes and use glue to put the pieces back together.

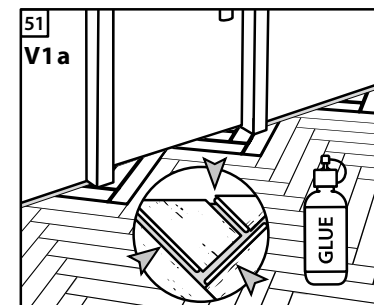
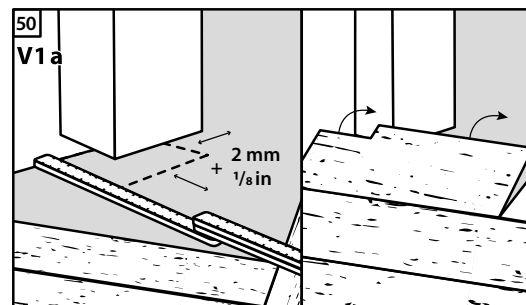
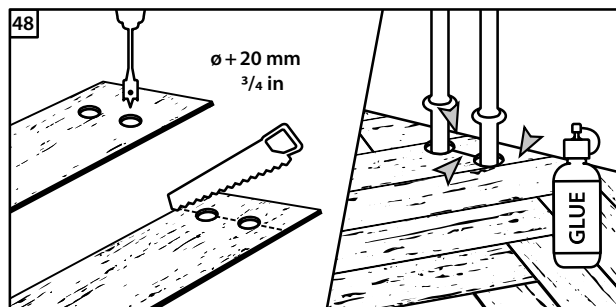
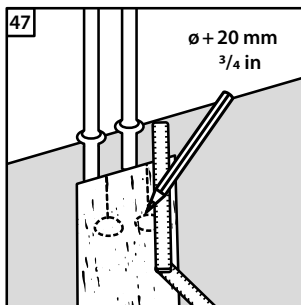

(Pattern variant V1b) The door frames are not shortened for this variant. Make sure that an expansion gap of 10 mm is maintained between all bordering components, including door frames. Carefully measure the width and depth of the door frame, add 10 mm to each side and transfer the measurements to the plank. Cut the plank to size and check for correct fit before installing it. Install the cut elements and ensure that the elements in the door area are firmly bonded to each other [49-51].

Installation near doors:

Shorten door frames so that the planks fit underneath (**pattern variant V1a**) or maintain an expansion gap of 10 mm between the door frame and the laminate flooring (**pattern variant V1b**).

Take extra care when laying and gluing the plank sections in the door area with particular care, as transition areas between rooms are usually subject to increased wear and tear.

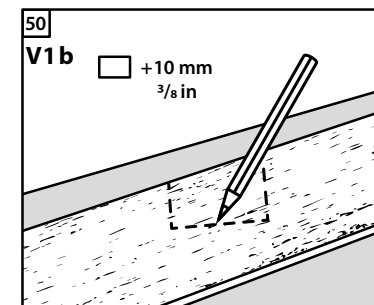
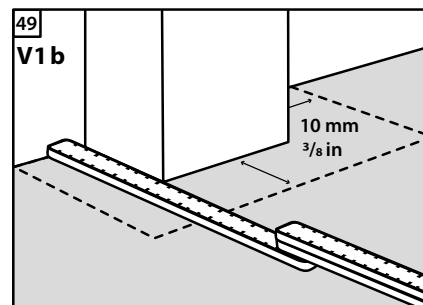
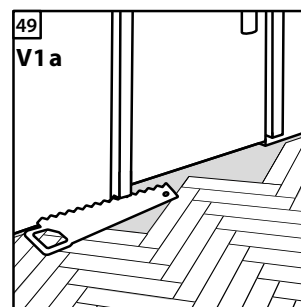

(Pattern variant V1a) Shorten the door frames so that the panel and impact sound insulation can be easily laid underneath with a gap of 2-3 mm. Measure the depth and width of each door frame and add 2 mm to each side. Transfer this measurement to the plank and cut it to size. Install the cut elements and ensure that the elements in the door area are always firmly bonded to each other [49-51].

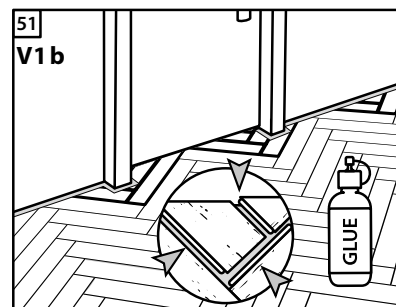

After installation:

Remove any shims used during installation for ensuring expansion joints to the wall.
Check that the indicated expansion joint spacing (at least 10 mm) to fixed components has been maintained throughout. If this is not the case, the flooring must be trimmed accordingly to ensure the necessary freedom of movement.

Install suitable skirting boards on the walls. The boards must avoid jamming or compressing the laminate in order to guarantee that the flooring has the necessary freedom of movement.
Carefully remove loose dirt and dust using a broom or a vacuum cleaner with a hard floor attachment.

8. GENERAL INFORMATION

Value retention [52–54]:

The use of felt glides under chair, table and furniture legs, suitable scraper mats and entrance mats of adequate size (textile mats, etc.), which must be cleaned regularly and replaced when necessary, and suitable office chair pads can prevent scratches and extend the life of your floor covering. Always use type W chair castors (soft). Interactions with other materials (e.g., discolouration under floor mats or carpets) cannot be ruled out and do not constitute grounds for complaint. Therefore, check the compatibility of the overlays in advance if at all possible. Do not place damp plant pots or the like directly on the flooring; always use suitable underlays.

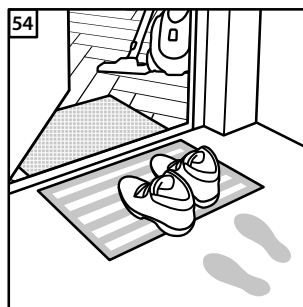
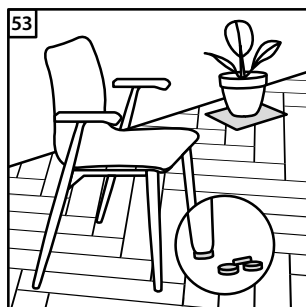
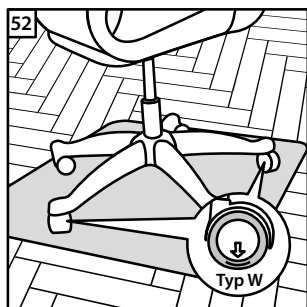

Cleaning and care [55]:

Classen Megaloc Twin Laminate Flooring is delivered ready for use and with a sealed surface. For this reason, never sand down the flooring or treat it with varnish or solvents.

Do not use cleaning agents that contain abrasive or film-forming substances.

It is best to clean the floor with a vacuum cleaner (hard floor attachment) or damp with clear water, if necessary adding a small amount of laminate cleaner.

Stubborn stains can be removed with undiluted cleaner and a cloth or non-scratch pad. Please follow the instructions in the Cleaning and Care Instructions for Laminate Flooring at

www.classen.com/service/downloadbereich/

Wipe up any spills immediately. Always remove water as quickly as possible.

Do not use steam cleaners, polishes, waxes or abrasive cleaners.

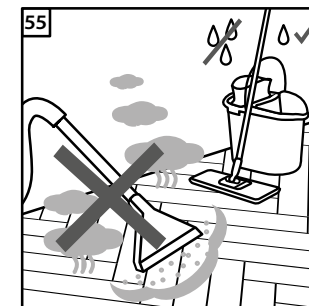

Disposal:

Residential: with normal household/bulky waste

Commercial: EU waste code No.: AW 170201

9. WARRANTY

To protect your warranty and guarantee claims, please be sure to keep the proof of purchase of your flooring. It is also helpful for you to keep a copy of these installation instructions, a packaging label and the production code printed on the back. This can be used to identify the production data later if required. The warranty declaration can be found at www.classen.com/service/downloadbereich/

DISCLAIMER

These installation instructions have been prepared to the best of our knowledge and with particular care. The details are based on practical experience and our own tests and correspond to our current state of knowledge at the time of publication. They are for informational purposes only and do not constitute a guarantee of product characteristics or suitability for specific purposes. We assume no liability for any printing errors, errors in standards or other mistakes. In addition, technical changes may result at any time from the continuous development of the products we produce and from changes to standards and public law documents. However, we cannot guarantee the installation result in each case due to the large number of possible applications (a complete list of which would be impossible) and because the conditions of storage, installation and construction sites are beyond our control.

The publication of this edition renders all previous editions invalid. Before use, please be sure to check our website at **www.classen.com**

If you have any questions about the product or processing, please contact our technical customer service hotline: **0800 1133313**



CLASSEN Holz Kontor GmbH
Werner-von-Siemens- Str. 18–20
DE 56759 Kaisersesch
www.classen.com
info@classen.de

**Intellectual
Property Rights:**

