

INSTALLATION INSTRUCTIONS FOR LAMINATE FLOORING

MEGALOC AQUA PROTECT INSTALLATION SYSTEM

DE / REV. 2.7 / 04.26

1. PREPARATION/STORAGE

Acclimatisation:

Allow CLASSEN laminate flooring to acclimatise prior to installation. To do this, stack the unopened boxes crosswise for at least 48 hours in the area where they will be installed. Please store the boxes at a distance of at least 30 cm from outside walls, heat sources and air conditioning systems. The temperature should be at least 18°C (64°F), the relative humidity 40 - 60%.

Inspection of the products

Please check the products for damage and obvious defects prior to installation. Do not install boards that have already been damaged prior to installation.

It is recommended that you install the floor covering in daylight or good lighting; otherwise, there is a risk that defects will not be detected. In the event of a subsequent complaint, no refund can be provided for panels that are installed despite an obvious defect.

2. SUBSURFACE CONDITION

Existing old coverings such as carpet, needle felt or PVC floor coverings must be removed completely. The subsurface must be solid, clean, level and dry (ready for installation according to DIN 18365, DIN 18202).

The moisture content of the subsurfaces is to be checked and must not exceed 1.8 CM-% for cement screed and 0.3 CM-% for anhydrite screed or anhydrite flowing screed.

The evenness of the subsurface is of particular importance. Compensation needs to be provided for the following:

- Height differences of more than 2 mm/m
- Recesses between adjacent surfaces

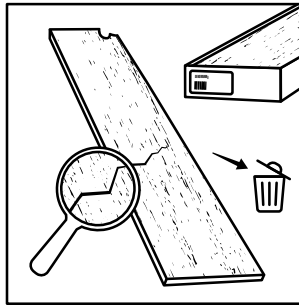
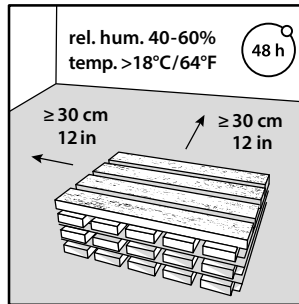
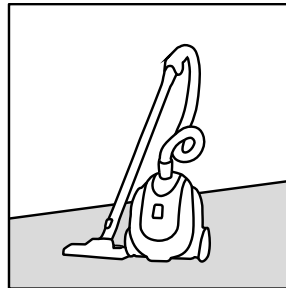
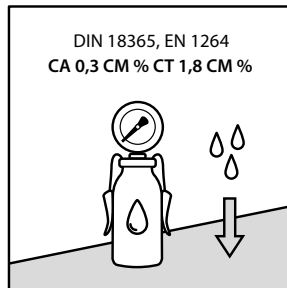
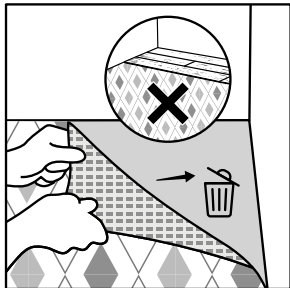

Mineral substraces and tiles

When installing on mineral substraces, always use a vapour barrier with an SD value of at least 75 m (see item 4). In the case of substraces that border on the ground, ensure that there is sufficient waterproofing on site.

Wood substraces

For substraces made of wood or wood-based materials, it must be ensured that the subsurface is level, vibration-free, dry, free of mould and insect infestation and sufficiently ventilated. The moisture content must not exceed 10%. The use of a PE film as a vapour barrier is not permitted on wooden substraces (prevention of condensation).

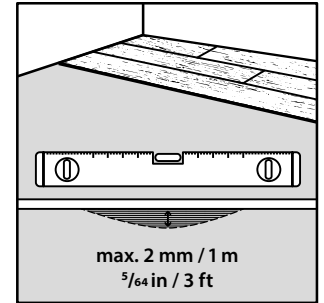

3. INSTALLATION MATERIAL AND TOOLS



- Spirit level, straight edge
- Vapour barrier, SD value > 75 m (PE film at least 0.2 mm)
- Impact sound underlay max. 3 mm construction height and min. CS value 60 kPa, min. CC value 20 kPa, DL25 min. 100,000 cycles
- Floor/transition profiles at room transitions (if required), end rails
- Folding rule, tape measure
- Angle bracket, bevel
- Carpet knife
- Pencil or felt pen
- 10 mm spacer wedges
- 50 mm wide moisture resistant adhesive tape
- Saw
- Hammer and tapping block (exclusively for installation under a door frame)
- Filling cord, e.g., a PE foam tape, silicone
- Optional: Drilling machine and drill, mitre saw, hacksaw, handsaw, laminate cutter

4. INSTALLATION UNDERLAYS

Installation underlays significantly affect the durability of the floor covering.

1. Vapour barrier
2. Impact sound underlay
3. Floor covering

Vapour barrier: A PE film as a vapour barrier on mineral substraces to prevent damage from rising damp is essential. This is fulfilled, for example, by a 0.2 mm thick polyethylene vapour barrier with an SD value of 75 m. The edges of the vapour barrier should overlap by approximately 20 cm and then be sealed with moisture-resistant tape. Allow the vapour barrier to run up the wall at least 2 cm and shorten it after attaching the skirting boards.

Impact sound underlay: In particular, the impact sound underlay affects sound transmission and thermal conductivity, along with the service life of the floor covering. The thickness of the impact sound underlay must not exceed max. 3 mm. We recommend compliance with the elevated requirements of the EPLF (Association of European Producers of Laminate Flooring) with a compressive strength (CS value) of min. 60 kPa (= 6 t/m²). In addition, the impact sound underlay should have a CC value of 20 kPa and a DL25 value of min. 100,000 cycles.

Requirement	Value	Unit
DL25	100.000	Cycles
CS	60	kPa at 0.5 mm compression
CC	20	kPa at 0.5 mm compression

Attention! For products with an impact sound underlay that is already integrated, no additional impact sound insulation may be used.

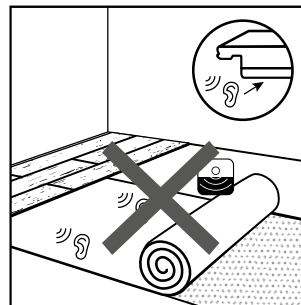
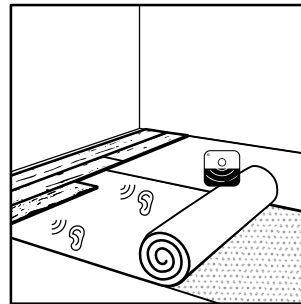
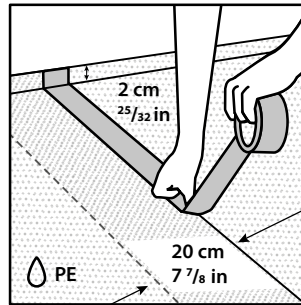
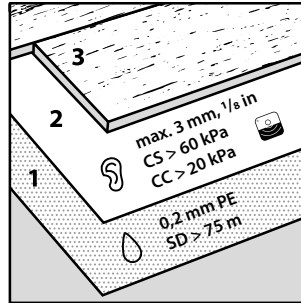

5. INSTALLATION ON UNDERFLOOR HEATING

The floor covering can be installed on underfloor heating systems (hot water and electric) without any problems if they are firmly installed in the screed and a surface temperature of 29°C is not exceeded.

Attention! A combination with electric heating foils, which are loosely laid / installed on the screed, is not permitted.

When installing on underfloor heating systems, the total thermal resistance of the floor covering and impact sound insulation must not exceed a value R of 0.15 m²K/W. For the R-value of the floor covering, please refer to the technical data sheets.

The impact sound insulation underlay to be used must always be suitable for use on a heated subfloor.

In principle, prior to installation, the heating engineer must carry out and document a functional and occupancy test in accordance with the regulations (further technical information can be found here: "Interface Coordination for Heated Underfloor Structures" at www.flaechenheizung.de).

For underfloor cooling systems, the R-value (thermal resistance) must be less than 0.10 m²K/W and the formation of condensation must be prevented by a suitable control / automatic shut-off system.

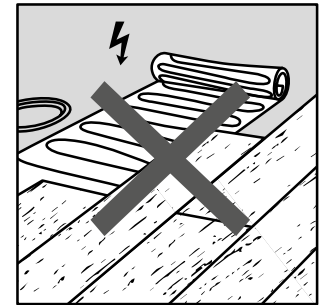
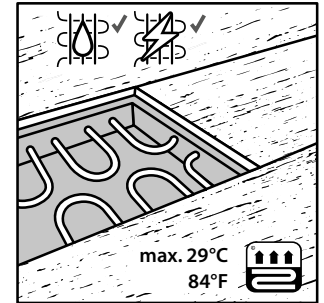

6. INSTALLATION

As a rule, the floor covering is installed in the longitudinal direction to the main light source.

The floor covering is intended for use in dry interiors under residential conditions.

Attention! Floors that are to be installed in a floating manner must never be firmly connected to the subsurface!

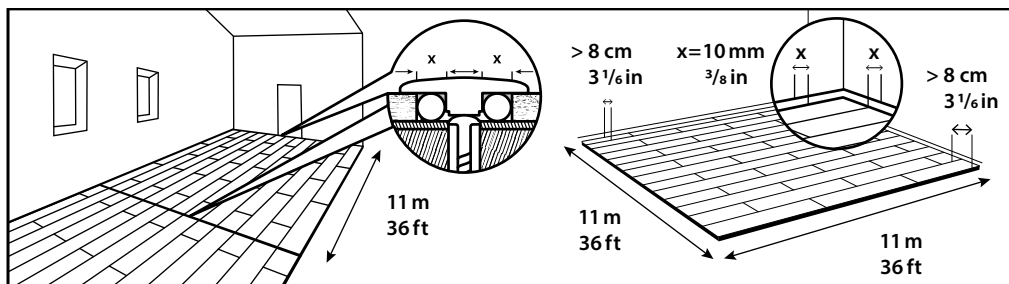
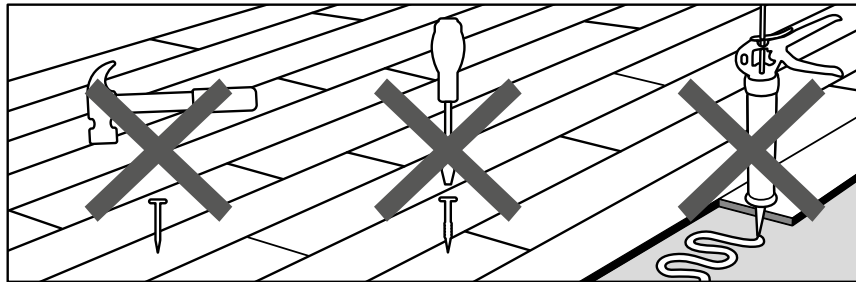
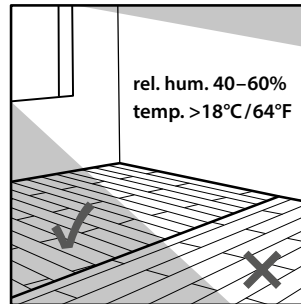

Movement joints of 10 mm must be maintained at transitions to other rooms and to all fixed components. For room dimensions of more than 11 m, additional expansion joints are to be provided.

- Additional expansion joints of 10 mm are to be provided at:
- All ascending components, e.g., heating pipes
- On-site limitations
- Around fixed objects like, e.g., kitchen units, ovens and doorsteps
- Between individual rooms, e.g., door threshold
- At the transition between two different floor covering

- In rooms with complex floor plans
- Expansion joints provided by the customer are to be incorporated in the surface covering

Around fireplaces, the floor must be protected from falling embers by a spark protection plate. For this purpose, the spark protection of at least 50 cm to the front and at least 30 cm to each side of the combustion chamber must be ensured. In order not to fix the laminate floor by the fireplace, the spark protection plate must be decoupled from the rest of the floor surface by a 10 mm movement joint.

Be sure to observe the legal requirements.

Installation in rooms with increased influence of humidity

CLASSEN Megaloc aqua protect is equipped with special moisture protection. Observe the special processing instructions under item 7 - Edge sealing.

ATTENTION! CLASSEN Megaloc aqua protect is not approved for installation in rooms with floor drains, in saunas or shower areas.

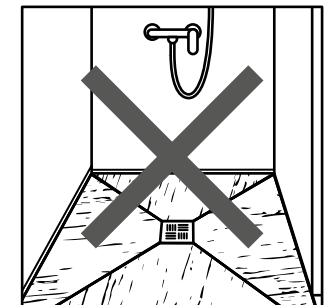
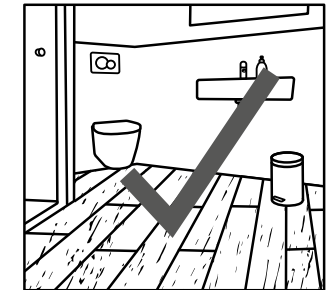
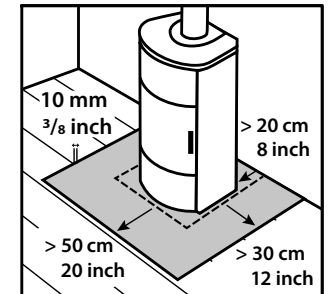

7. STEP-BY-STEP INSTALLATION

First, install the vapour barrier (see item 3) and the impact sound insulation underlay prior to installing the first element. Make sure that the individual strips of the impact sound insulation underlay are laid flush against each other, but do not overlap.

NOTE! Fix the butt edges together with adhesive tape. By doing so, you can avoid slipping of the individual strips.

Prior to starting the installation, clean the room and measure the width of the room. The minimum width of the elements of the first and last row should be at least 8 cm. If cutting is necessary, shorten the elements of the first row on the tongue side and the elements of the last row on the groove side.

NOTE! Start the installation on the side of the room where the door is located, so that the installation of the last row ends at a free wall without doors or other on-site obstacles.

Installation is always from left to right..

Place the first boards against the wall as “guide boards”, always with the long profile side with the tongue facing the wall.

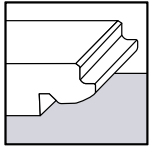

Tongue = wall side

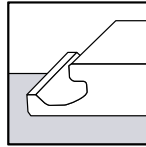

Groove = room side

These guide boards are laid with a gap and must not be connected to each other at the short edges, since they are only used for the correct installation of the first three rows and are then removed again.

Installation of the first row:

Connect the first board to the guide board by inserting the tongue of the long side into the groove of the long side of the guide board at an angle of 20° - 30° and slowly lowering it so that it locks into place. Make sure that the first board has a distance on the left edge of 10 mm from the wall. This distance is called the expansion joint.

The second board is installed to the right of the first board, by

- 1) inserting the tongue of the long side into the longitudinal groove of the guide board at an angle of 20° - 30°.
- 2) slowly sliding the second plank to the left until the planks butt together
- 3) lowering the second board to lock the cross profile

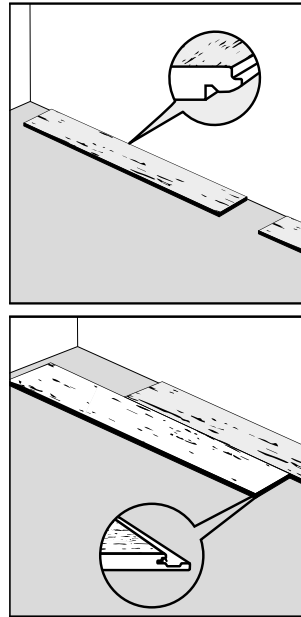
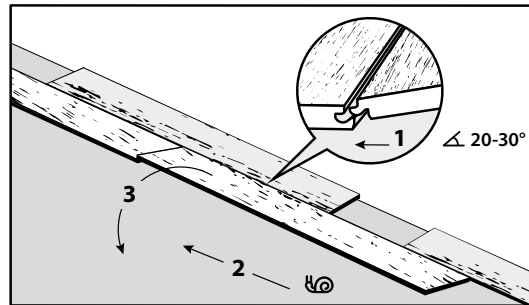

To do this, press down the second board in the area of the head profile several times, starting from the applied corner, in order to lock the head profile correctly.

ATTENTION! Never hit the elements together with a hammer, as this can irreparably damage the profile connections!

Continue in this way until the first row is completely installed.

Cut the last board to fit, making sure there is also a 10 mm expansion joint between the end of the row and the wall.

When cutting a board using a jigsaw, the decorative surface should face downwards to avoid cracks on the surface. If you use a hand or table saw, the decorative surface should face upwards.

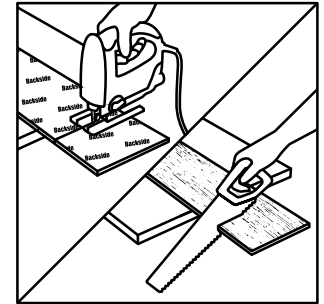
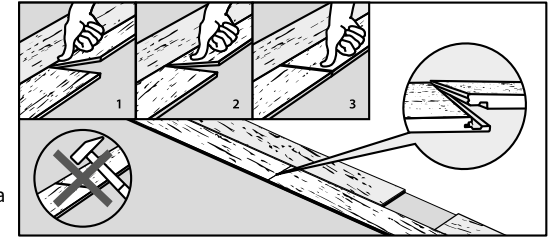

Installation of the second row and the following rows:

Use the remaining piece of the last board of each row to start a new row if the remaining piece is at least 1/3 of the length of a whole element and the short edges from row to row have an offset of at least 1/3 of the length of a whole element. If this is not possible, use a new board and cut it accordingly.

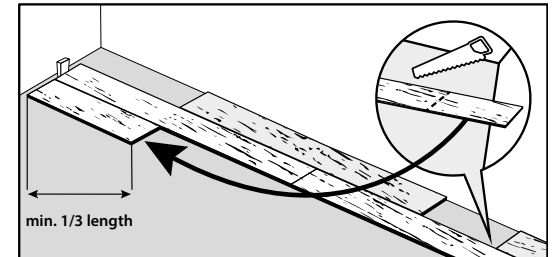

When the first three rows are installed, remove the guide boards and push the installed rows towards the wall, taking care to maintain an expansion joint of 10 mm to the walls.

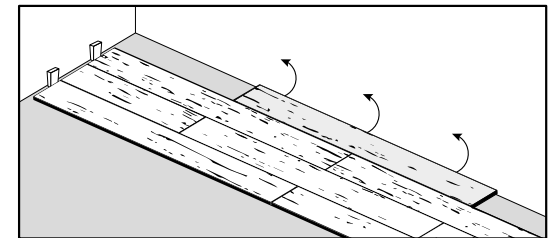

If necessary, the first row can now still be adjusted to the wall contour.

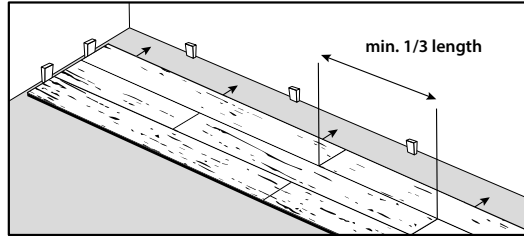

ATTENTION! An expansion joint of 10 mm must be maintained to pipes and all other objects rising on site. When installing boards around pipelines, cut the holes approximately 20 mm larger than the diameter of the pipe. Then cut through the centre of the holes and use glue to put the pieces back together.

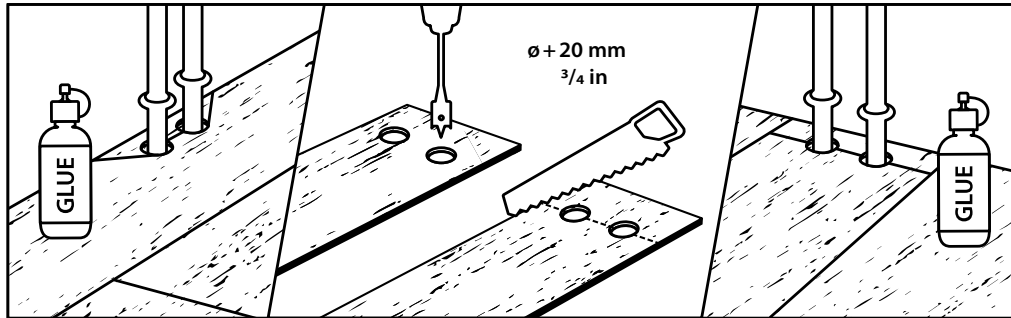
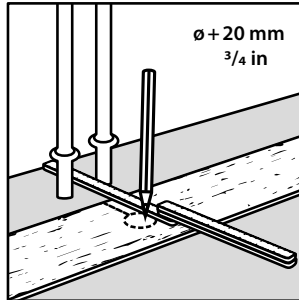

Installation in the area of doors:

Shorten door frames so that the boards fit underneath (installation variant V1) or maintain an expansion gap of 10 mm between the door frame and the laminate flooring (installation variant V2).

For both variants, ensure that the minimum board width is 8 cm and that the board connects next to the door opening and the door frame.

(V1) Remove the upper piece of the bottom groove cheek on the short edge of the previously installed board so that the tongue can slide into the groove unhindered. Using sandpaper (120 grit), sand along the bottom tongue of the long edge of the board to be installed 5 - 6 times, so that it is easier to slide the board under the door.

Connect the long spring side of the board to the previously installed row. Apply some wood glue to the bottom groove cheek and gently tap the board into place until it is connected to the previously installed board. For this purpose, always use a tapping block and always tap against the tapping block and never directly on the profile.

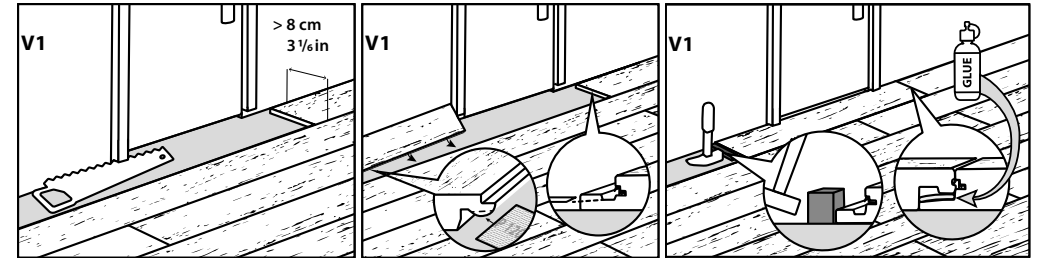

(V2) Measure the depth and width of each door frame and add 10 mm to both sides and depth. Cut the appropriate cut-outs in the board.

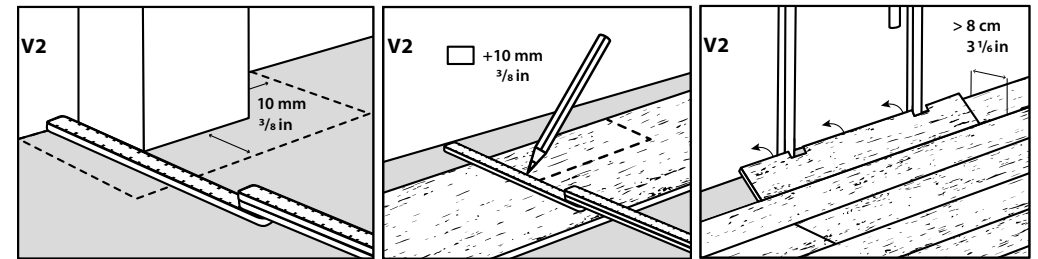

Remove all spacer wedges when the floor covering is completely installed.

Edge sealing:

Make a watertight seal by filling all expansion joints and the areas at the transition rails with a compressible filler cord, e.g., a PE foam tape, and cover them with a suitable silicone sealant.

DO NOT use acrylic sealants.

Install the baseboards only after the drying time of the sealant.

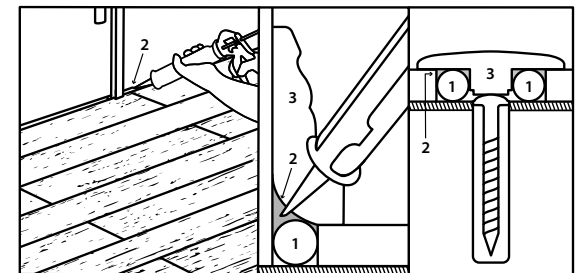

1: PE foam baker rod / PE Schaum Band, 2: Silicone / Silikon, 3: Molding / Leiste

Uninstalling the elements:

Prior to disassembling the floor, first angle the whole row and lift it out of the articulated joint on the longitudinal edge. Only then separate the individual elements from each other by sliding the elements apart parallel to the head edge.

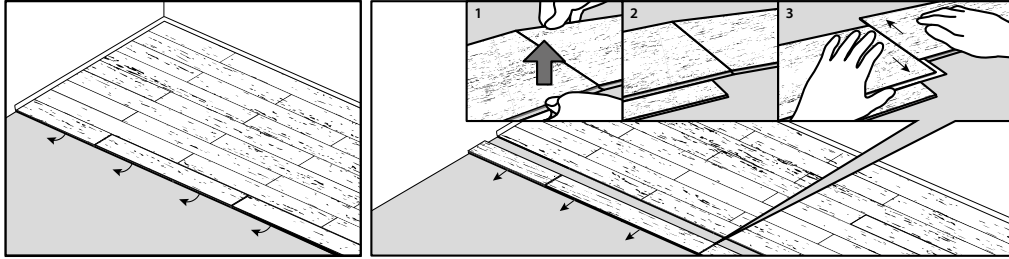

NOTE! Disassemble from right to left; it may be helpful to carefully lift the joined head edges slightly and place another floor element under the right end of the left element and then push the elements apart. Only a disassembly that is correct and damage-free ensures that the floor can be installed several times.

8. GENERAL NOTES

Value retention:

The use of felt glides under chair, table and furniture legs, suitable dirt-trapping and clean-running zones (textile mats, etc.), which must be replaced if necessary, and suitable office chair pads can prevent scratches and extend the life of your floor covering. Use chair castors of type W (soft). Interactions with other materials (e.g., discolourations under floor mats or carpets) cannot be ruled out and cannot constitute grounds for a complaint. Therefore, if possible, check the compatibility of the supports in advance. Do not place wet plant pots or the like directly on the ground; always use suitable underlays.

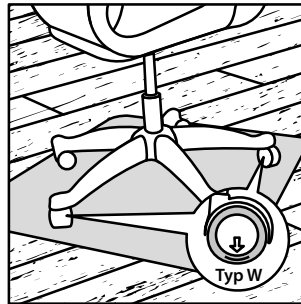
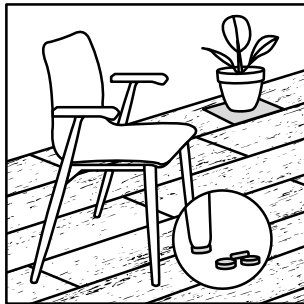

Cleaning and care:

Classen Megaloc aqua protect laminate floors are supplied ready-for-use and surface-sealed. Therefore, the floor must never be sanded or treated with varnish or treated with solvents.

Do not use cleaning agents that contain abrasive or film-forming substances.

It is best to clean the floor with a vacuum cleaner (hard floor nozzle) or damp with clear water, if necessary adding a small amount of laminate cleaner.

Stubborn stains can be removed with undiluted cleaner in conjunction with a cloth or non-scratch pad. Please follow the instructions in the Cleaning and Care Instructions for Laminate Flooring at

www.classen.com/service/downloadbereich

Wipe up any spills immediately. Always remove water as quickly as possible.

Do not use polishes, waxes or abrasive cleaners.

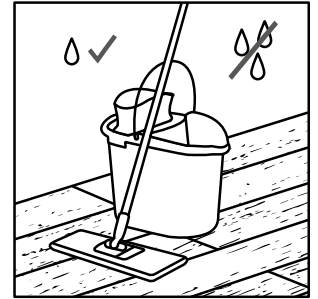

Disposal:

Personal: Via normal household/bulky waste

Commercial: EU waste code no: AW 170201

9. WARRANTY

To protect your warranty and guarantee claims, please be sure to keep the proof of purchase of your flooring. It is also helpful if you document a copy of these Installation Instructions, a packaging label and the production code printed on the back. This can be used to determine the production data later if required. The warranty declaration can be found at

www.classen.com/service/downloadbereich

Standard notice:

Subject to technical changes. Created on the basis of the current state of the art, which means that all previous versions are no longer valid

DISCLAIMER

These installation instructions have been prepared to the best of our knowledge and with particular care. The details are based on practical experience and our own tests and correspond to our current state of knowledge at the time of publication. They are for informational purposes only and do not constitute a guarantee of product characteristics or suitability for specific purposes. We assume no liability for any printing errors, errors in standards or other mistakes. In addition, technical changes may result at any time from the continuous development of the products we produce and from changes to standards and public law documents. However, we cannot guarantee the installation result in each case due to the large number of possible applications (a complete list of which would be impossible) and because the conditions of storage, installation and construction sites are beyond our control.

The publication of this edition renders all previous editions invalid. Before use, please be sure to check our website at **www.classen.com**

If you have any questions about the product or processing, please contact our technical customer service hotline: **0800 1133313**



CLASSEN Holz Kontor GmbH
Werner-von-Siemens-Str. 18–20
D-56759 Kaisersesch
www.classen.com
info@classen.de

**Intellectual
Property Rights:**

