



Rückschlagventil PN 40

Baulänge DIN 3202-4 M8 Innengewinde ISO 228/1

Werkstoff 1.4408 (AISI 316) Anwendungsbereich: -20°C bis max. +180°C

Piston Check Valves PN 40

end to end DIN 3202 part 4 series M8 Thread ISO 228/1

Material 1.4408 (AISI 316) Temperature Range: -20°C till +180°C

RV561

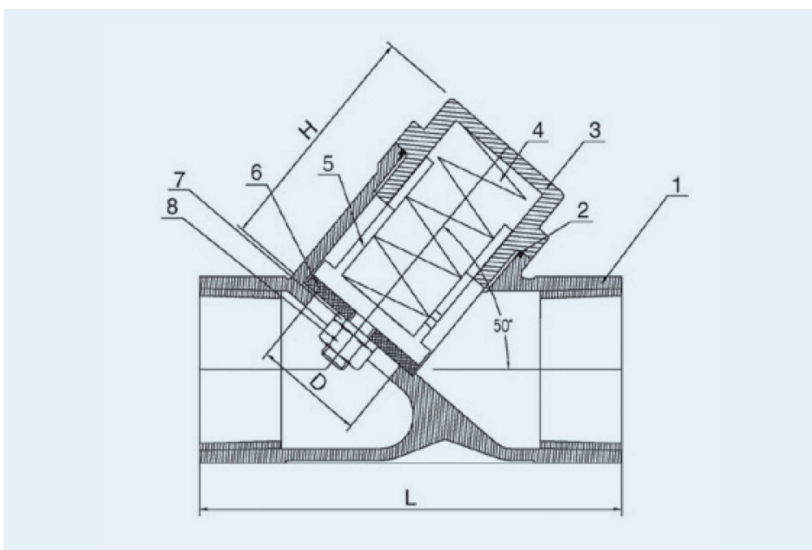

Nr. / No.	Teile / Parts	Material
1	Gehäuse / Body	CF8M / 316 / 1.4408
2	Gehäusedichtung / Body Seal	PTFE
3	Gehäuseoberteil / Bonnet	CF8M / 316 / 1.4408
4	Feder / Spring	SS316
5	Ventilkolben / Valve Piston	SS316
6	Sitzdichtung / Valve Seal	PTFE
7	Federring / Spring Washer	SS304
8	6-Kt. Mutter / Hex Nut	SS304

Abmessung					Gewicht	Artikelnummer	
	Dimension						
	DN	L	H	D	kg	Item No.	
1/4"	8	65,5	31,0	11,6	0,175	RV561014T	○
3/8"	10	65,5	31,0	12,5	0,170	RV561038T	○
1/2"	15	65,5	31,0	12,5	0,165	RV561012T	■
3/4"	20	75,5	40,0	18,0	0,270	RV561034T	■
1"	25	90,5	50,0	23,5	0,565	RV561100T	■
1 1/4"	32	111,0	55,0	31,4	0,720	RV561114T	■
1 1/2"	40	121,0	70,5	35,7	1,540	RV561112T	■
2"	50	151,0	87,0	45,5	2,505	RV561200T	■
2 1/2"	65	190,0	118,0	60,0	4,440	RV561212T	○
3"	80	220,0	136,0	76,0	5,976	RV561300T	○

Alle Maße in mm / All sizes in mm
Technische Änderungen vorbehalten / Technical changes reserved

■ Standard-Lagerartikel / warehouse stock ○ Auftragsbezogene Fertigung / order related production