

**0 INHOUD VAN DE KIT - CONTENU DU KIT - CONTENTS INSTALLATION KIT - INHALT KITT**

**TWINSTOR**

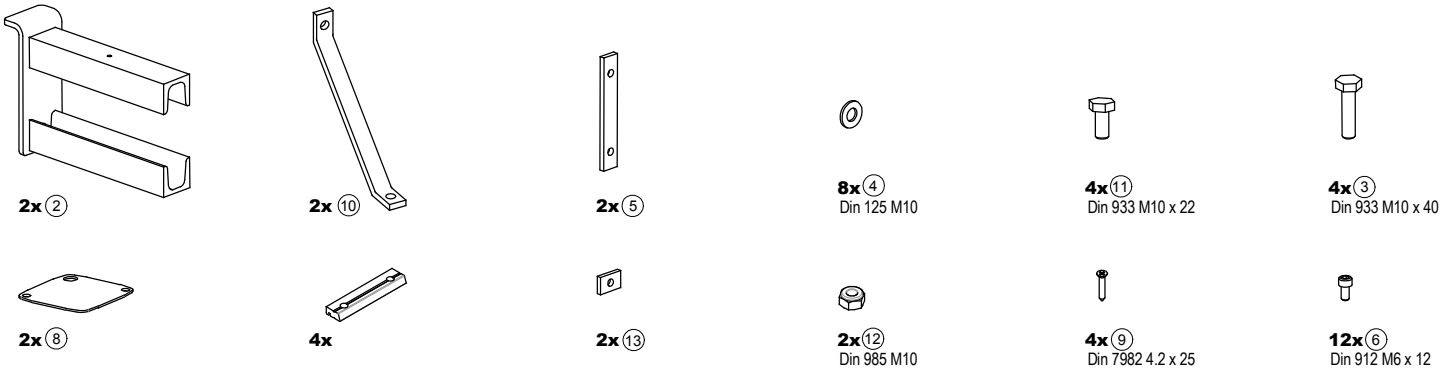

**1 MONTAGE VAN HET FRAME - MONTAGE DU CADRE  
INSTALLATION OF THE FRAME - MONTAGE DES FRAMES**

**2 OPTIE BLOEMBAK - OPTION BACA FLEURS -  
OPTIONAL FLOWERBOX - OPTION BLUMENKASTEN**

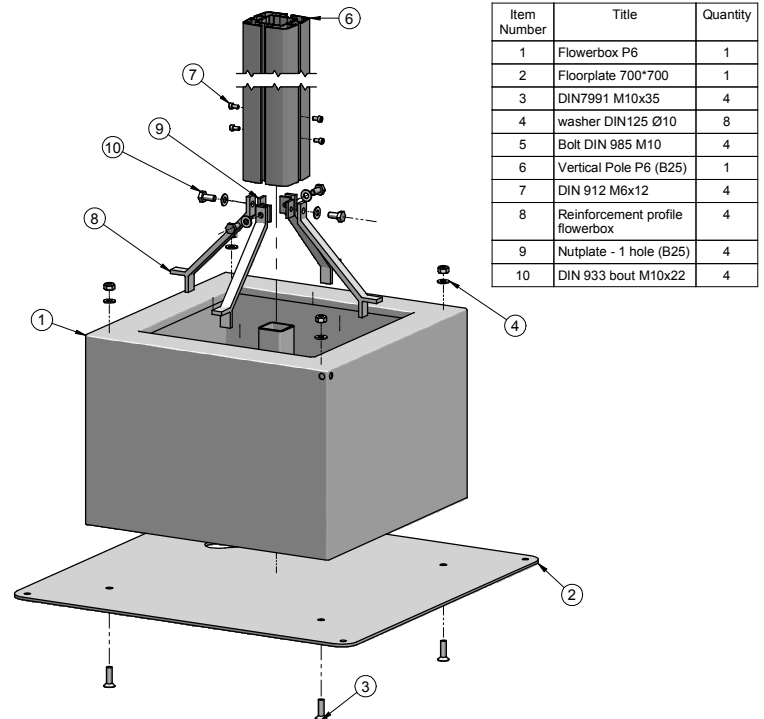
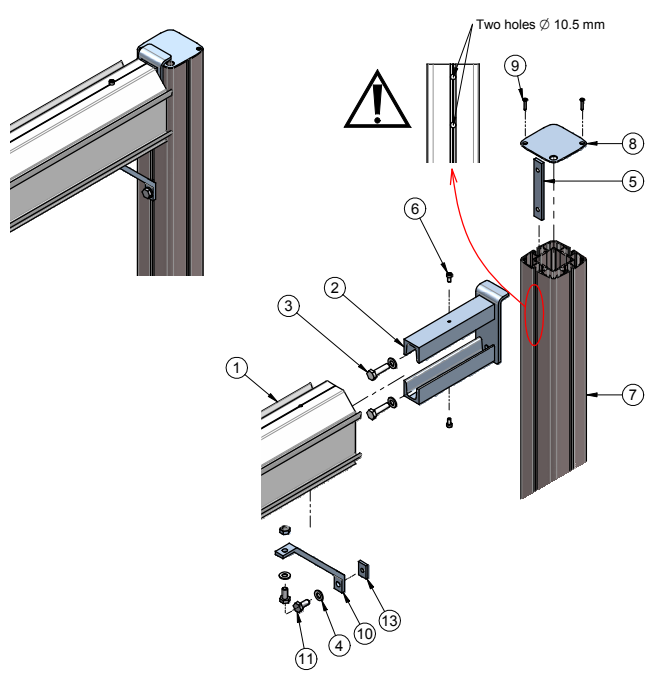

**3 MONTAGE GRONDANKER - MONTAGE DU PIED FIXE A ENTERRER - INSTALLATION OF THE GROUNDANCHOR - MONTAGE GRUNDANKER**

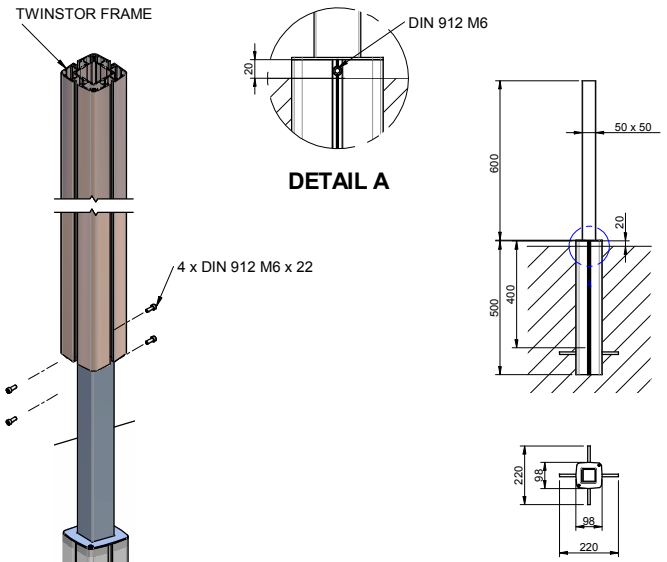
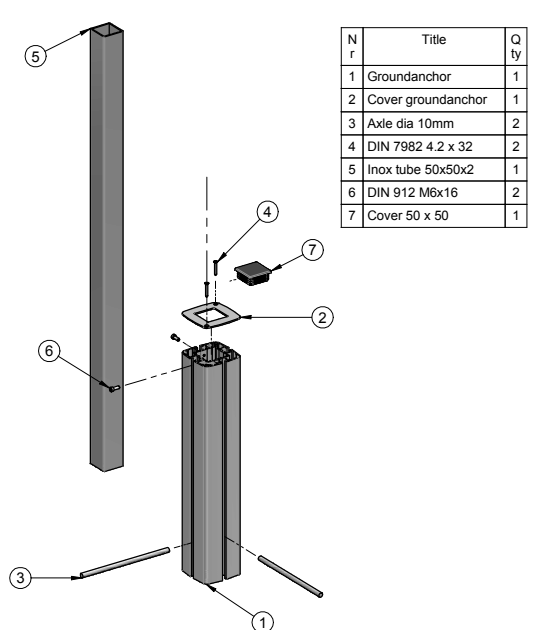

4

## BEVESTIGEN IJFELS - MONTER LES STORES - INSTALLATION OF AWNINGS - BEFESTIGUNG MARKISE

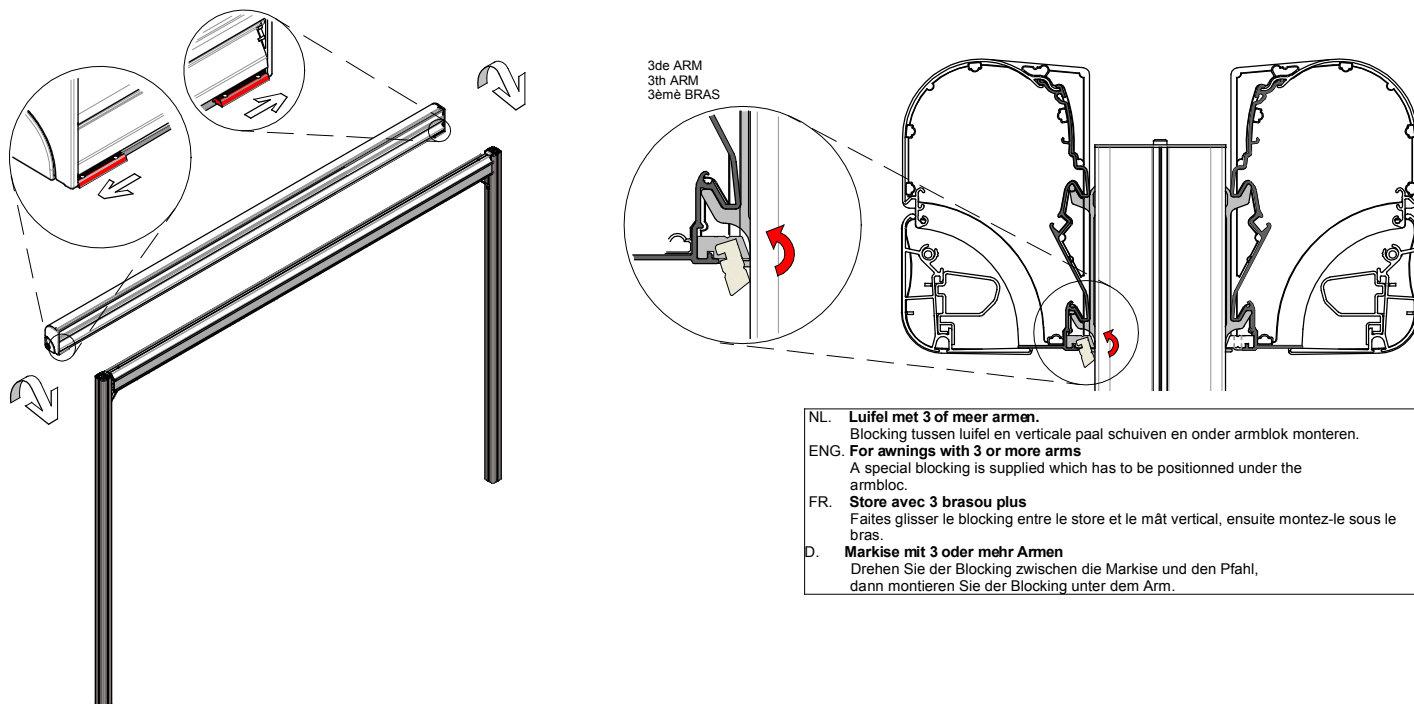

- NL. **Luifel met 3 of meer armen.**  
Blocking tussen luifel en verticale paal schuiven en onder armblok monteren.
- ENG. **For awnings with 3 or more arms**  
A special blocking is supplied which has to be positioned under the armbloc.
- FR. **Store avec 3 bras ou plus**  
Faites glisser le blocking entre le store et le mât vertical, ensuite montez-le sous le bras.
- D. **Markise mit 3 oder mehr Armen**  
Drehen Sie der Blocking zwischen die Markise und den Pfahl, dann montieren Sie der Blocking unter dem Arm.

5

## BEDRADING MOTOR - CABLAGE DU MOTEUR - WIRING OF THE MOTOR - VERDRAHTUNG MOTOR

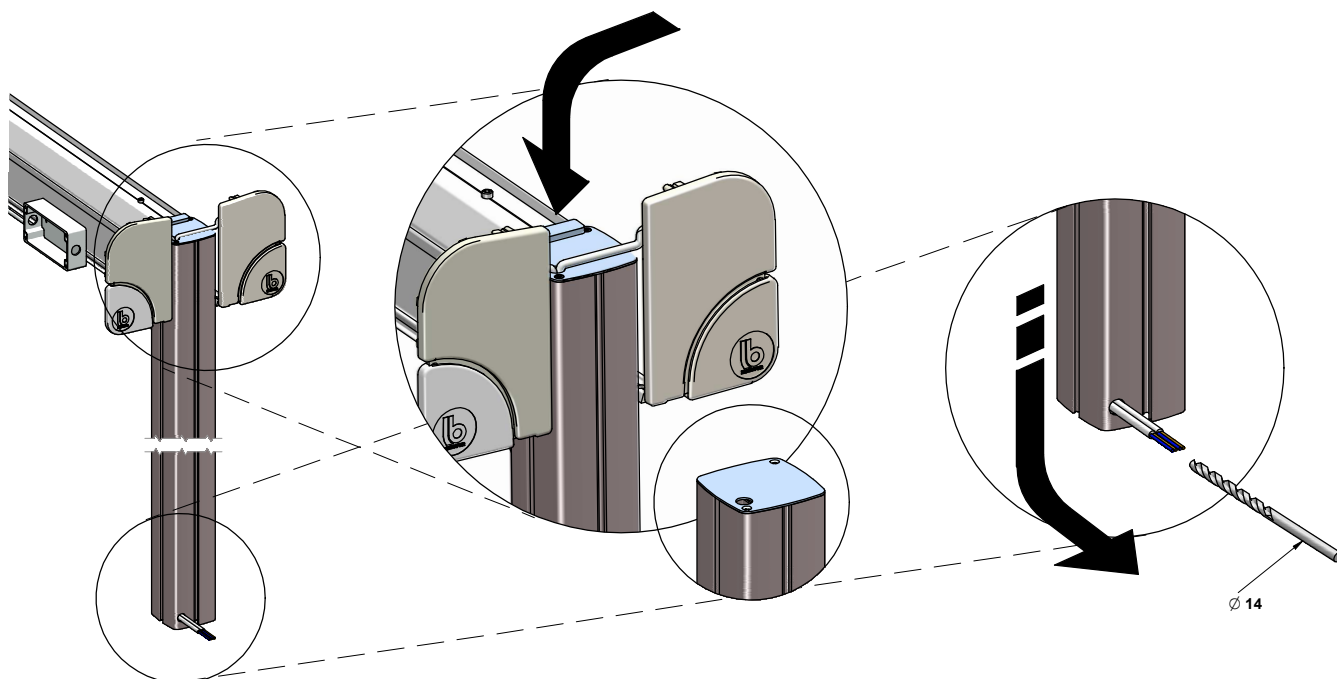

6

## BEDRADING VERWARMING - CABLAGE DU CHAUFFAGE - WIRING OF THE HEATING - VERDRAHTUNG HEIZUNG

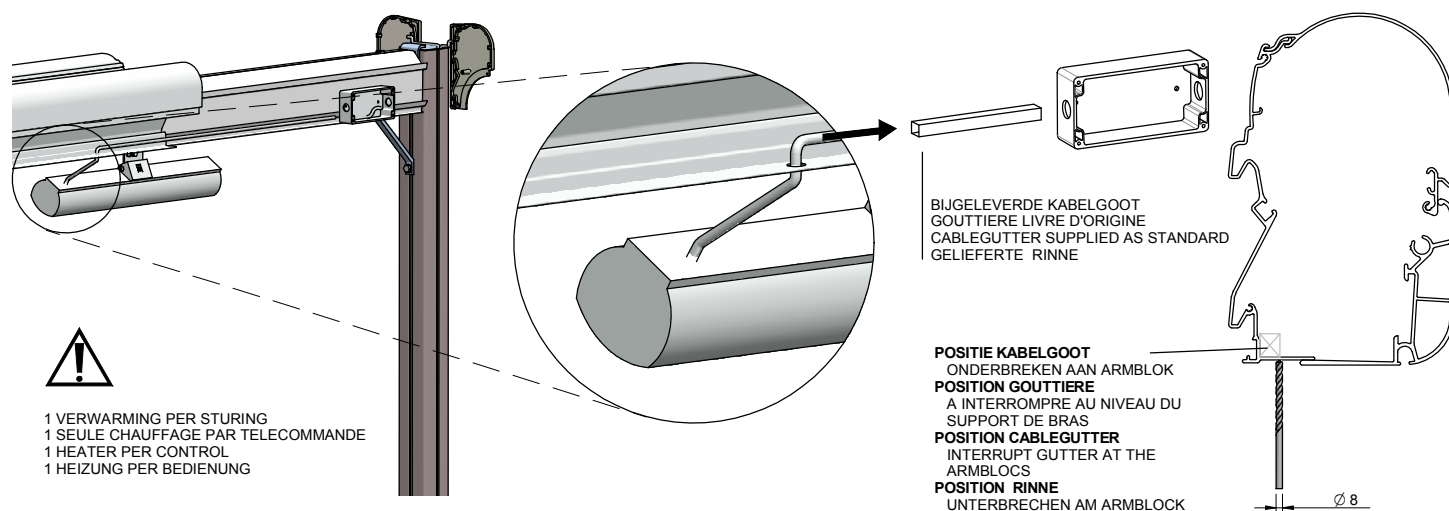

- 1 VERWARMING PER STURING  
1 SEULE CHAUFFAGE PAR TELECOMMANDE  
1 HEATER PER CONTROL  
1 HEIZUNG PER BEDIENUNG