

Three-phase Meter Quick Guide



1. Overview

DTSU666 series three phase four wire electronic energy meter(din-rail) is designed based on power monitoring and energy metering demands for electric power system, communication industry, construction industry, etc. as a new generation of intelligent instrument combining measurement and communication function, mainly applied into the measurement and display for the electric parameters in the electric circuit including three voltage, three current, active power, reactive power, frequency, positive&negative energy, four-quadrant energy, etc. Adopting the standard DIN35mm din rail mounting and modular design, it is characterized with small volume, easy installation and easy networking, Can be applied into Growatt Hybrid inverter and AC coupled inverter.

2. Technical Parameters

General Specifications		Enviroment	
Rated voltage	3×230/400Vac	Rated temperature	-10℃~+45℃
Reference frequency	50Hz/60Hz	Limit temperature	-25℃~+70℃
Specified operating voltage range	0.9Un~1.1Un	Relative humidity(average annual)	<75%
Extended operating voltage range	0.8Un~1.15Un	Atmosphere	63.0kPa~106.0kPa
Voltage line power consumption	≤1.5W/6VA	Installation category	CAT III
Input current	0.25-5(80)A	Degree of pollution	Conform to RoHS
Starting current	0.004Ib	Communication	
AC voltage withstand	2KV /5mA for 1 minute	Communication	RS485 output for Modbus RTU
Impulse voltage withstand	4KV-1.2/50uS waveform	Baud rate	9600
Max. Reading	9999999kWh	Pulse	400imp/kWh
Accuracy		Mechanics	
Active power	1% of range maximum	Din rail dimensions	100x72x65(LxWxH)
Reactive power	2% of range maximum	Mounting	DIN rail 35mm
		Sealing	IP51 (indoor)

3. Unpacking

Item	Number	Description
A	1	Three phase meter
B	1	Rs485 cable (standard length 5m)
C	1	User Manual

4. Dimension (Unit: mm)

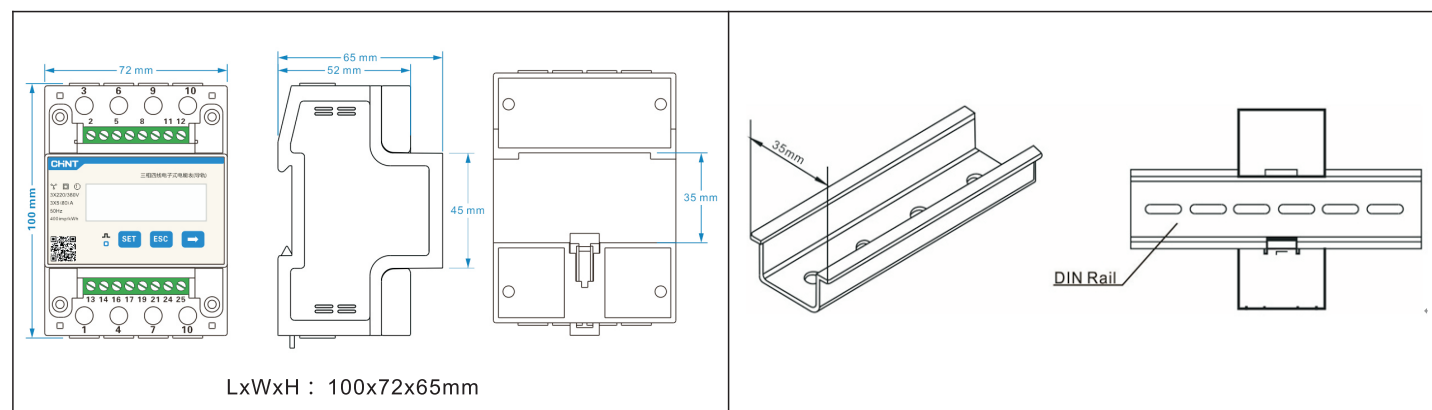

5. Installation

三相四线直接接入

Three-phase four-wire connected indirectly

Communication and pulse output terminal

LAN line 1-8 colors as below:

PIN	1	2	3	4
Clour	White orange	Orange	White green	Blue
PIN	5	6	7	8
Clour	White blue	Green	White brown	Brown

Note: We describe Growatt hybrid inverter as "SPH" as below.

a. When SPH series products are used in three-phase power grid system, please set the "Sensor: Cable CT" of SPH as "Sensor: Meter". More details, please refer to SPH user manual.

b. For example, when connecting three-phase energy meter, SPH gets the information of the sum of three-phase active power to process the logical control by RS485 communication. The following figure is a diagram of the SPH working system.

Note: As shown in the figure above, a switch must be installed at point A. In the process of use, if the SPH needs to be turned off, please turn off the switch at point A.

c. Install the three-phase energy meter in inlet AC distribution cabinet, and connect it to utility grid(L1, L2, L3) according to responding indicator mark. The arrow on the meter indicates the grid access port.

d. Connect the A+ (White-Blue) of Rs485 cable to Pin24 and B- (White-Orange) of it to Pin25.

e. Connect the end of the RS485 cable to SPH RJ45(Sensor) port.

f. The standard RS485 cable length is 5m. If the length is not long enough, please add another cable to extend the length.

Note:

1. Be careful the wire of input and output of L/N and the range of input voltage or current, if the data is outrange, it may destroy the meter.
2. Be careful the input and output of meter line, if lines are wrong, system will work in a wrong way.

Note: If there is no commuication(SP shows warning 401 or meter communication indicator is don't display), please check the communication LAN line, baud rate, and address.

6. Display

From the displayed interface, the electrical parameter and energy data are all primary side data (that is, the multiplied by current and voltage ratios). The energy measuring value will be displayed seven bits, with the displaying range from 0.00kWh to 9999999Mwh.

Diagram 1 Liquid crystal display

NO	Display interface	Instruction	NO	Display interface	Instruction
1		Positive active energy =10000.00kWh	10		Phase C current =5.002A
2		Reserve active energy =2345.67kWh	11		Combined phase active power =3.291kW
3		Communication protocol is ModBus-RTU. N1 indicates that there are 1 stop bits without parity. 9.600 indicates that the baud rate is 9600bps 001 indicating table address	12		Phase A active power =1.090kW
4			13		Phase B active power =1.101kW
5		Phase A voltage =220.0V	14		Phase C active power =1.100kW
6		Phase B voltage =220.1V	15		Combined phase power factor Pft=0.500L
7		Phase C voltage =220.2V	16		Phase A power factor Pfa =1.000L
8		Phase A current =5.000A	17		Phase B power factor Pfb =0.500L
9		Phase B current =5.001A	18		Phase C power factor Pfc = -0.500L

Note: This meter and SPH default communication address is 04, the baud rate is 9600, if the meter and SPH communication is not on, you can confirm the communication address and baud rate is accurate, view and modify the path as follows:

Button description: "SET" button represents "confirmation", or "cursor shift"(when input digits), "ESC" button represents "exit", "→" (↵) button represents "add". The input code is (default 701).

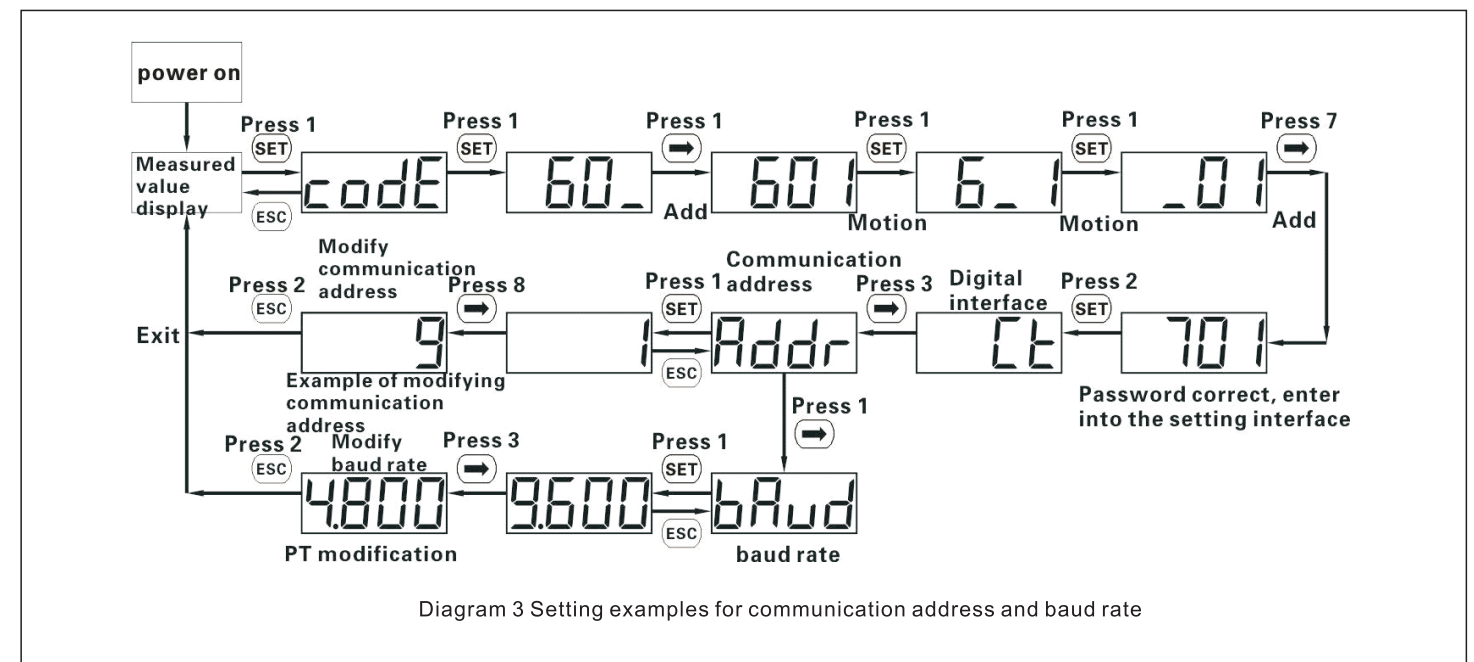
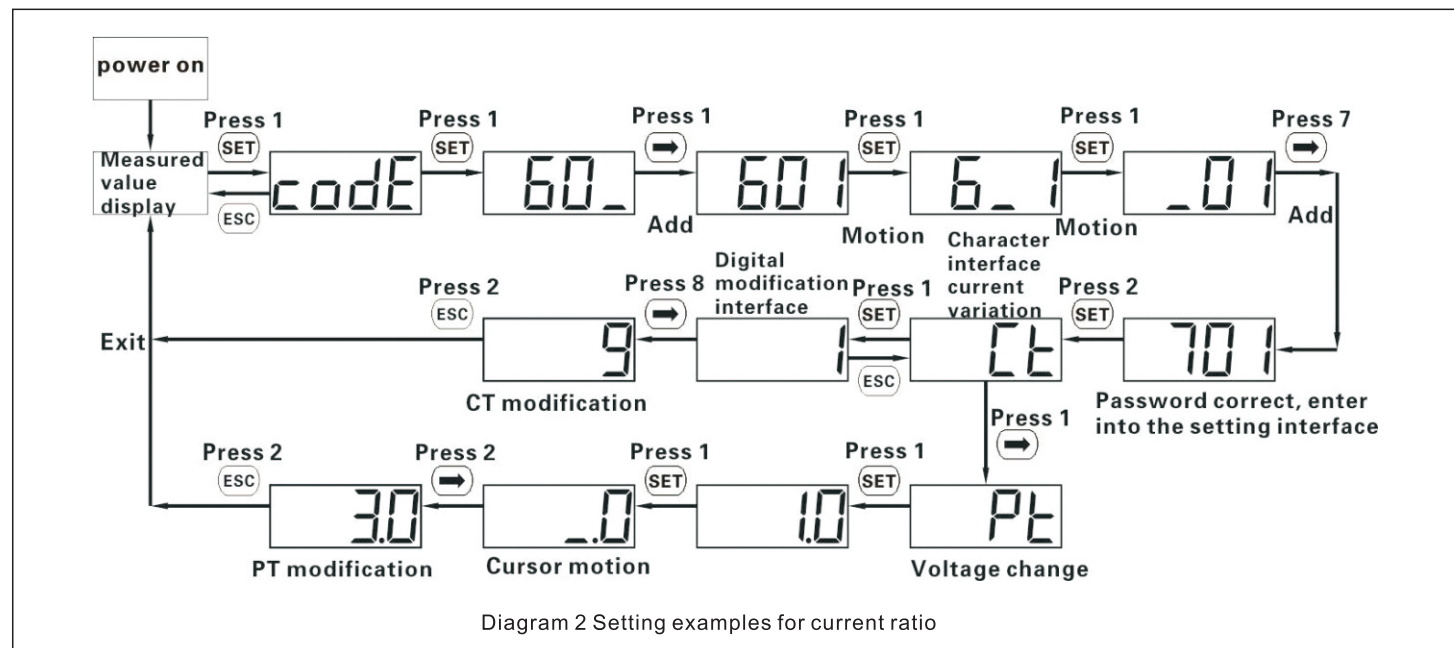

7. Trouble shooting

Fault phenomenon	Reason analysis	Elimination
Big deviation between electric energy measurement and actual value.	<ol style="list-style-type: none"> If it is wrongly connected, please reconnect based on the right wiring mode (see the wiring diagram). If not the above problems, please contact with the local supplier. 	<ol style="list-style-type: none"> Wiring error, voltage and current corresponding phase sequence is correct? If the ends of the incoming and downstream ends of the current transformers reversed?
The downstream power data and the upstream power data are not displayed in the SPH.	The downstream power data and the upstream power data are not displayed in the SPH.	<ol style="list-style-type: none"> Check the "CT mode" of SPH is "energy meter mode". Check the voltage between A+ and B- is within the range of +(4.4~4.5)V; Check the RS485 communication cable is right. That is to say the A+/B+ of energy meter is matched to A+/B- of SPH. Also, make sure the wiring is fixed firmly.



Download Manual



Growatt New Energy

Shenzhen Growatt New Energy Technology CO.,LTD
 No.28 Guangming Road, Shiyan Street, Bao'an District, Shenzhen, P.R.China
 T +86 0755 2747 1942
 E service@ginverter.com
 W www.ginverter.com
 GR-UM-170-A-01