



# CatchTheLight

## User Guide

REDEMPTION

MULTIPLAYER

VIDEO

CLASSIC

SPEED & REFLEX



Made in Europe by



King of Boxers



## WELCOME

Thank you for choosing our product!

Our machines are fully computerized coin-operated skill or strength testers used for amusement and entertainment. You can use them in bars, pubs, amusement parks and other places of entertainment.

We made sure that all the components used for production as well as the machine itself are made of best quality components and are safe for use.

Your machine is designed so that you can start using it right away.

# CAUTION

## SAFETY PRECAUTIONS

### BE SURE TO READ THE FOLLOWING

**Warning:** Always turn OFF power and unplug the game before opening or replacing any parts.

**Warning:** Always when unplugging the machine from electrical outlet, grasp the plug, not the cord.

**Warning:** Always connect the machine to grounded electrical outlet.

**Caution:** The wiring system is under voltage that is safe in normal use but may be harmful while improper use.

**Caution:** Always use digital multimeter, logic tester or oscilloscope for testing integrated circuits.

**Caution:** Do not connect or disconnect any of the integrated circuits while the machine is ON.

**Caution:** Do not install any fuse that does not meet the specified rating.

**Caution:** Do not subject the machine to extreme temperature variations.

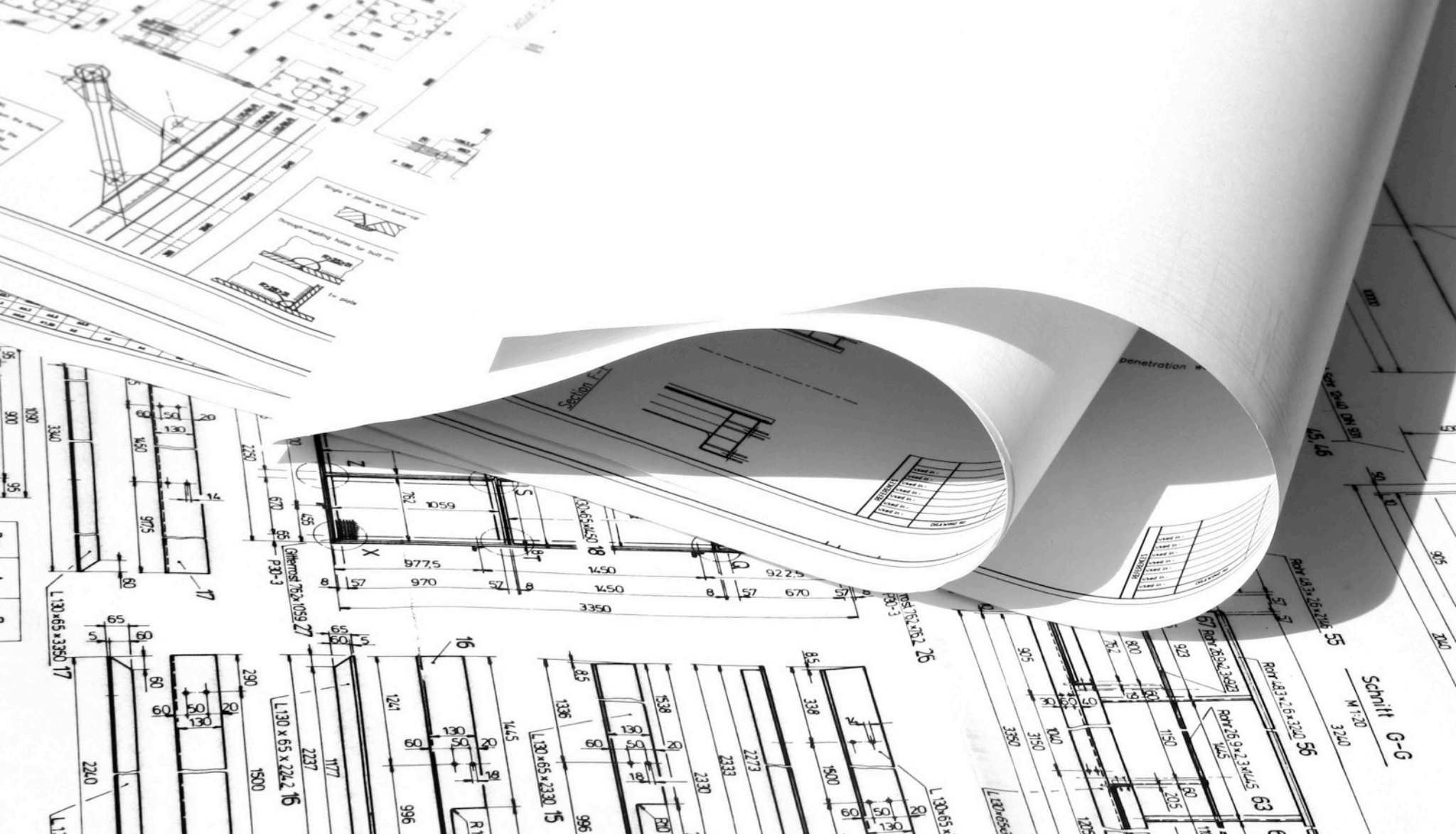

# MACHINE DESCRIPTION AND TECHNICAL SPECIFICATION

## What's in the package

Machine is supplied with a full range of accessories to help you get started right away.

- Key set for 2 locks.
- Preinstalled SD card.
- 4 legs with set of screws.
- Safety bar (wooden or pneumatic, stored inside the machine).

## **General information**

Game type: speed/reflex meter

Allocation: indoor

Construction: steel

Color: white

## **Operating dimensions and weight**

Width: 127cm / 50 inches

Depth: 79cm / 31 inches

Height: 87cm / 34 inches

Weight: 78.5kg / 173 lbs

## **Shipping Size and Weight in Cardboard Box**

Width: 128cm / 50"

Depth: 80cm / 32"

Box height: 43cm / 17"

Box on pallet height: 58cm / 23"

Machine in box weight: 82kg / 181lbs

Machine in box on pallet weight: 94kg / 208lbs

## **Shipping Size and Weight in Wooden Box**

Width: 134cm / 53"

Depth: 84cm / 33"

Box height: 48cm / 19"

Box on pallet height: 63cm / 25"

Machine in box weight: 124kg / 274lbs

Machine in box with pallet weight: 136kg / 300lbs

## **Electrical and operating requirements**

Power: 90V - 250V

Current frequency: 50Hz - 60Hz

Average power consumption: 30W

### **Currency**

Working with all kinds of bills, coins and tokens.

Possibility of installing both coin and bill acceptors.

### **Optional extensions**

- SMS acceptor.
- Two ticket dispensers.
- Coupon printer.

### **Casing and glass**

Casing: steel.

Glass: tempered glass, 6 mm / ¼ inch thick.

### **Display**

Segment display: red & blue score, credit and best score display with 88 flashing points.

Time display: 24 LED points.

### **Software regulated features**

- Volume.
- Credit settings.
- Ticket dispenser settings.
- Free-play mode.
- Button lit time.

- Lit buttons limit.
- Clear active credits.
- Default settings recovery.

**Notice:** See full description of software regulated features in the [Settings](#) section.

## Operation modes

1. OFF
2. Normal operation mode
  - a. Standby
  - b. Waiting for START
  - c. Game
3. Settings
4. Software update

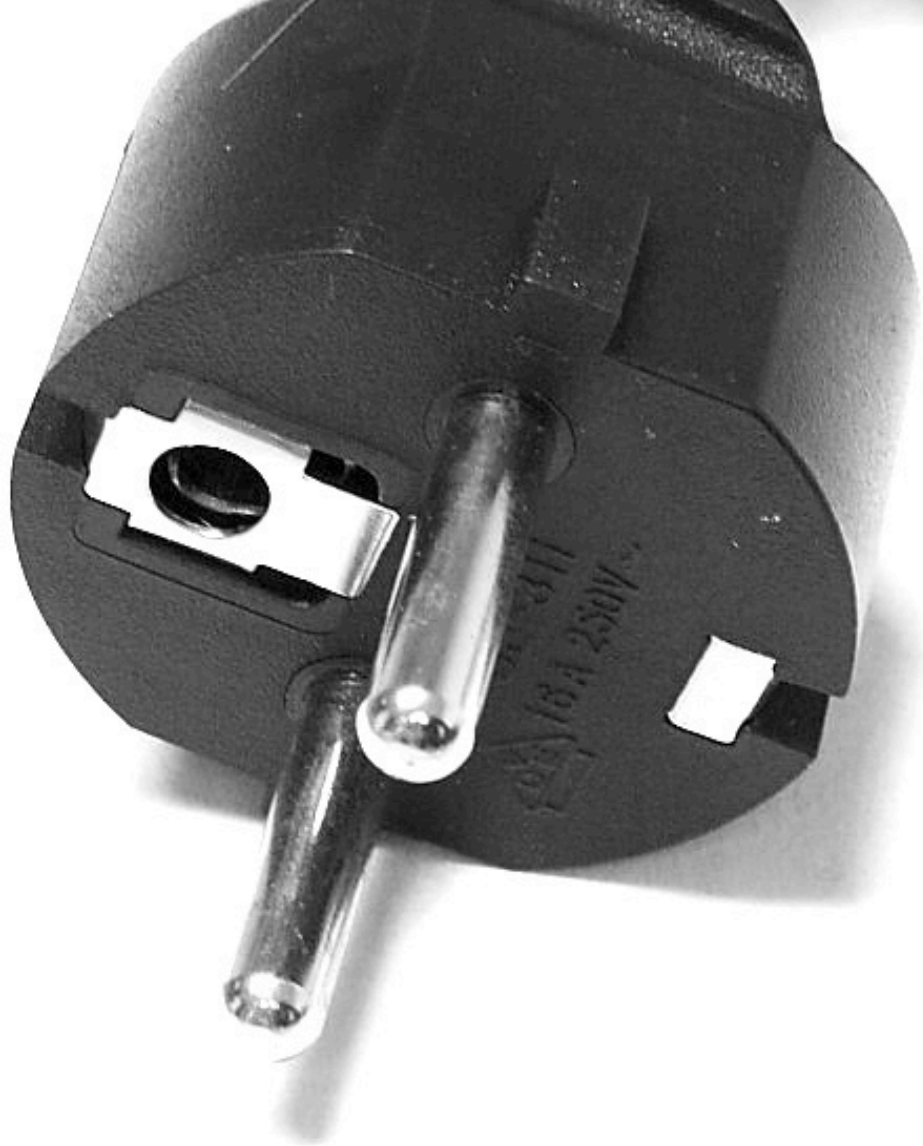

## INSTALLATION AND MAINTENANCE

The machine is designed so that you can set it up quickly and start using it right away.

### Installation

1. Take the machine to desired location.

**Warning:** Do not install the machine in areas that would present an obstacle in case of an emergency.

**Caution:** To move the machine for transport, use a forklift and take care not to hit the package. Do not stack any objects on top of the machine, as this may cause damage.

2. Take the machine out of the shipping box.

3. Install machine legs.

**Notice:** Legs are stored inside the machine or in a separate package (depending on shipment conditions). Set of screw is stored inside the money box.



**Notice:** Make sure that the machine stands securely on the ground.

**Caution:** Always use safety bar when working with open machine.

4. If the machine is cold, open machine and wait about 30 minutes for the electronics to warm up.

5. Connect the power cord to power outlet and check if machine is working.

## **Volume adjustment**

1. Turn ON the machine and wait for normal operation mode.

2. Open machine and locate main board.

3. Use UP to navigate to position VPL in settings menu.

4. Press ENT and use UP and DOWN buttons to adjust volume value.

5. After adjusting press ENT to confirm new setting.

6. Press ESC to go back to normal operation mode.

## **Cleaning**

Use paper towels and window cleaner to clean the machine.

Do not apply window cleaner or any other liquid directly on the machine. Instead apply it on the paper towel.

**Caution:** Machine works under high voltage. Always turn machine OFF before cleaning.



# HOW TO

## HOW TO PLAY

1. Insert coin or bill.
2. Press START button and wait for the buttons to illuminate.
3. Press lit buttons until time runs out.
4. Watch your score on the display.
5. Collect your tickets.

**Notice:** ticket dispensers are optional.

# ADJUST

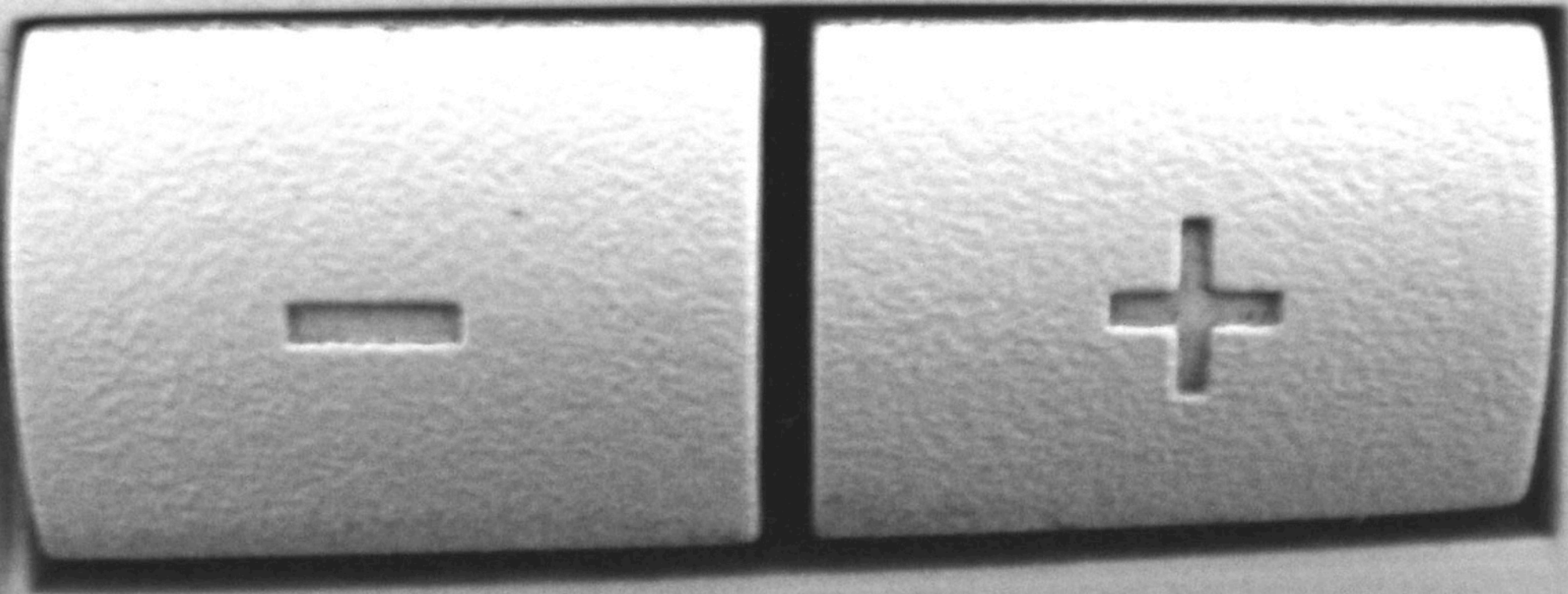

## SETTINGS

### How to access and browse through settings menu

1. Turn ON the machine and wait for normal operation mode.

**Notice:** Find out more about machine operation modes in [Machine description and technical specification](#) section.

2. Open machine and locate main board.

**Caution:** Machine works under high voltage.

3. Press UP to enter settings menu. Use UP and DOWN to browse the menu.

4. Use ENT to enable value changing mode. Use UP and DOWN to adjust value. When done use ENT to save changed value.

**Notice:** You can also use lit buttons at the top of the machine.

## Settings description

		Description
02		Game counter
04		Dispensed tickets counter
21	<b>CAC</b>	Coin acceptor type (serial/parallel)
23	<b>PL1</b>	Credits quantity for one pulse on first channel of coin acceptor
24	<b>PL2</b>	Credits quantity for one pulse on second channel of coin acceptor (if used)
25	<b>PL3</b>	Credits quantity for one pulse on third channel of coin acceptor (if used)
26	<b>PL4</b>	Credits quantity for one pulse from bill acceptor
41	<b>VPL</b>	Machine volume
43	<b>LoD</b>	Button lit time
44	<b>NoL</b>	Lit buttons at one time limit
45	<b>GAT</b>	Game time in seconds
46	<b>FrE</b>	Free play mode
61	<b>tDt</b>	Ticket dispenser mode (continuous /pulse)
62	<b>T 1</b>	Tickets for winner *
63	<b>T 0</b>	Tickets for loser *
64	<b>PT1</b>	Extra tickets - first stage point threshold **
65	<b>nT1</b>	Extra tickets - first stage ticket quantity **
66	<b>PT2</b>	Extra tickets - second stage point threshold **
67	<b>nT2</b>	Extra tickets - second stage ticket quantity **
68	<b>PT3</b>	Extra tickets - third stage point threshold **
69	<b>nT3</b>	Extra tickets - third stage ticket quantity **
70	<b>PT4</b>	Extra tickets - fourth stage point threshold **
71	<b>nT4</b>	Extra tickets - fourth stage ticket quantity **
81	<b>CrE</b>	Clear active credits
82	<b>dFL</b>	Restore default settings

\* - Set ticket quantity that winner and loser will get when the game is over.

\*\* - Set point threshold and ticket quantity to reward players for reaching high scores.

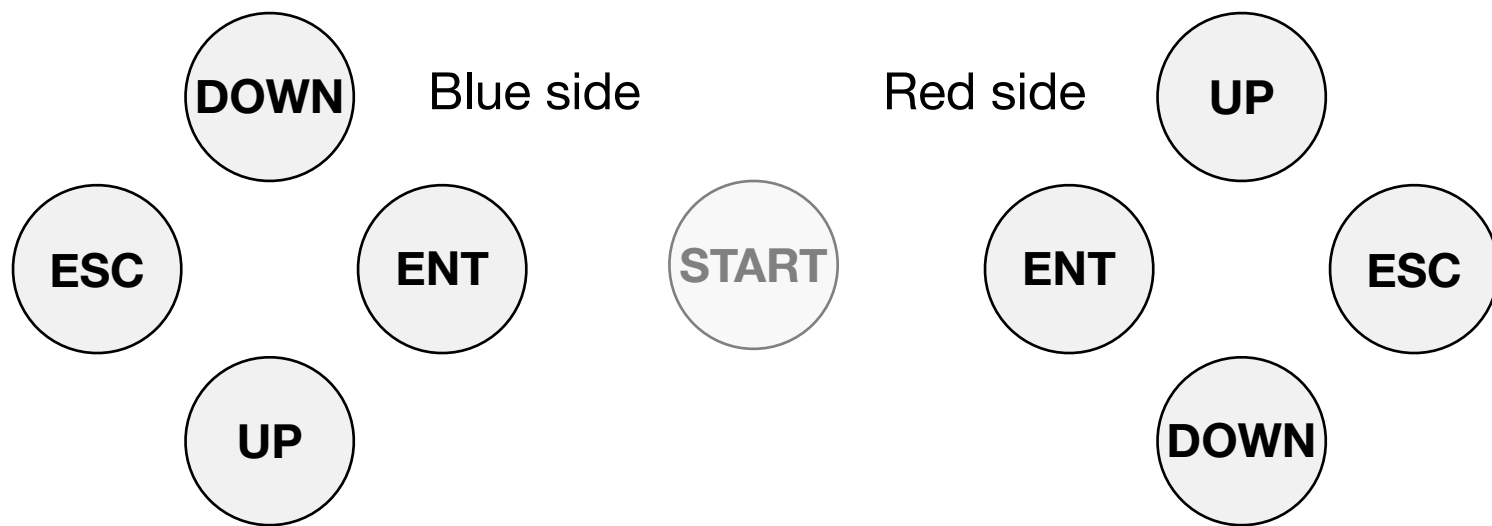

### How to exit settings and apply changes

All values are stored immediately after making any changes. You don't have to reboot the machine in order to apply changes.

Browse through the menu using UP and DOWN buttons. To exit the menu press ESC or restart the machine.

### How to read counters

Counters can display large numbers (up to 6 digits) and are using both scores displays. For example: when reading tickets counter, you'll see:

- **002** on the left display
- **491** on the right display

It means that the machine gave **2.491** tickets. Number on the credit display is just an order number of this settings menu position and it's not relevant to the counter value.



## ELECTRONICS DESCRIPTION

### Button switch

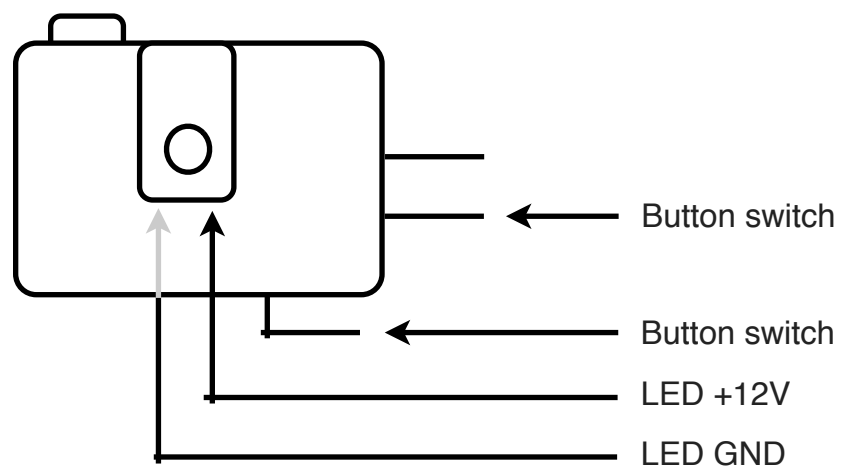

## Main board general description

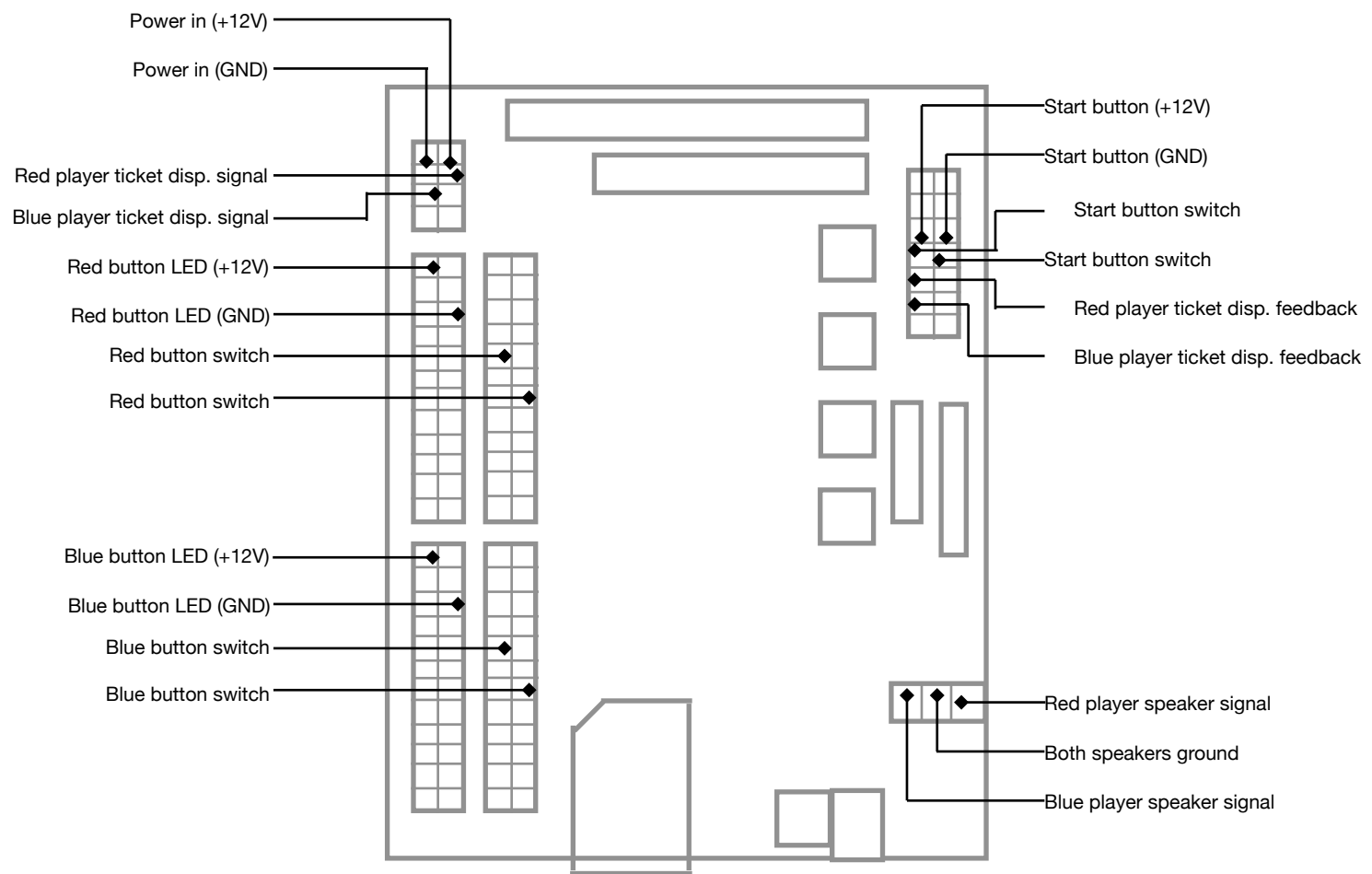

## Coin-acceptor connector

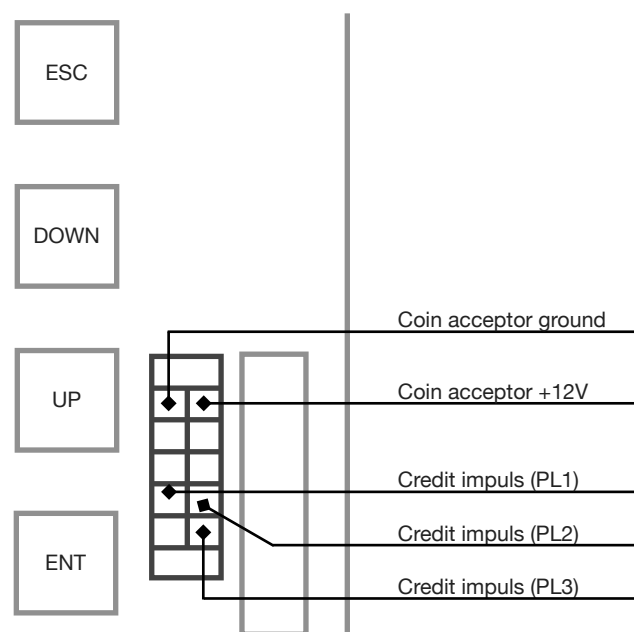

## Bill-acceptor connector

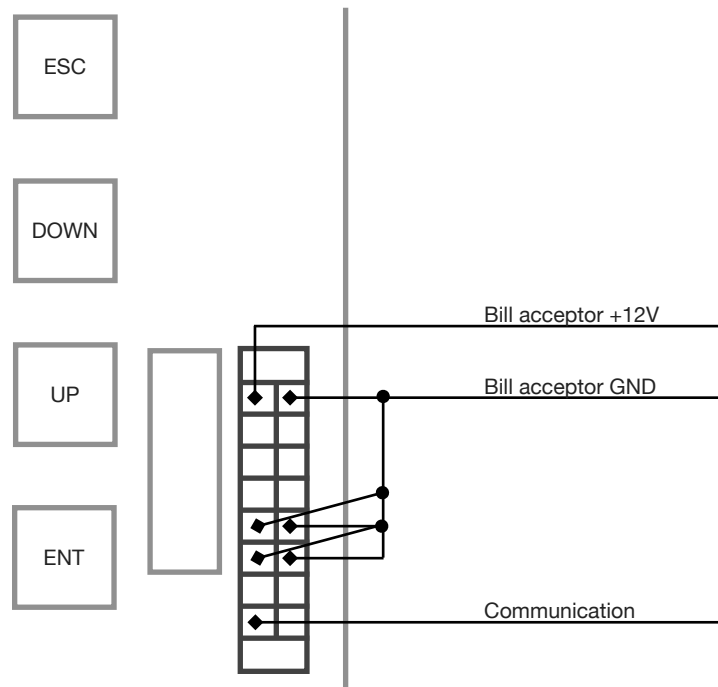

## Buttons and displays

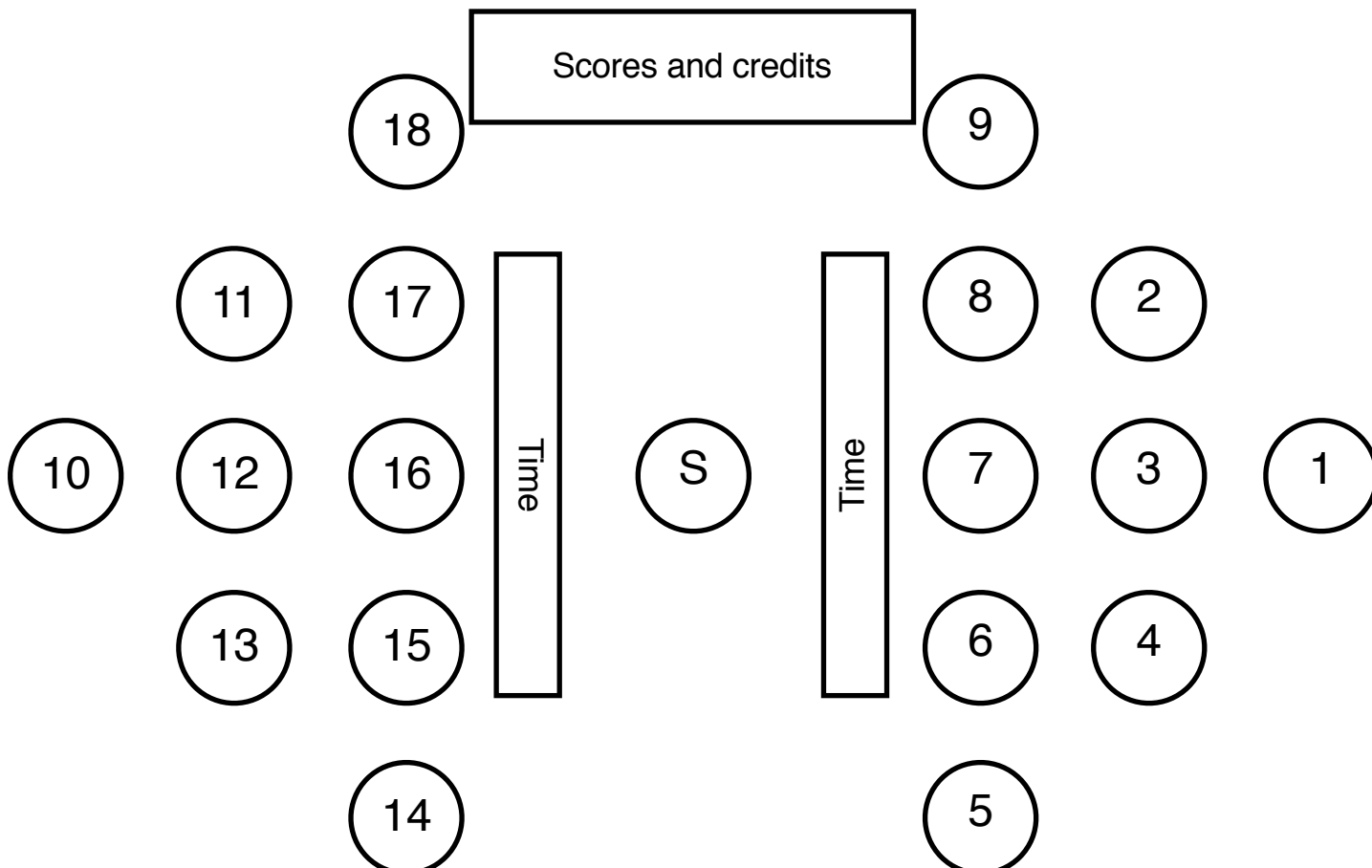





## SD CARD REPLACEMENT AND SOFTWARE UPDATE

### **Card replacement**

1. Turn OFF the machine, open it and locate SD card on the main board.
2. Press the card and it will pop out of socket.
3. Insert new card securely.
4. Close the machine and turn it on.

### **SD card software update**

1. Turn ON the machine and check current software version on the credit display. Version number is displayed only when machine is initializing.
2. Turn OFF the machine, open it and locate SD card on the main board.

3. Press the card and it will pop out of socket.

4. Connect the card to your computer using a card reader.

**Warning:** Do not use Mac OS X. Macintosh operating system creates hidden indexing files on all connected drives. Those files can corrupt the main board.

**Notice:** Make sure that your card reader is high quality and the USB cable can power the reader. Some low-quality card readers need additional power supply to work correctly.

5. Check if on the SD card is an old .hex file. If so remove it and empty the trash.

6. Place new .hex file on the card.

**Notice:** You can request .hex file from Kriss-Sport Support.

7. Use your operating system hardware removal tool to safely remove the SD card from the reader.

8. Put the SD card back in the socket on the main board.

9. Turn on the machine and wait for the update procedure to complete.

**Notice:** While updating first you'll see „BOOT” message on the display, next „ENDBOO”, and finally „INIT”. After that machine will start normally.



## TROUBLESHOOTING

### **Machine won't turn on**

1. Check if power outlet is working correctly.
2. Check if power supply inside the machine is working (green LED should be on)
3. Check if power in connector is connected correctly to the main board.

### **No sound**

1. Check if volume setting is not set to 0.
2. Check if speakers are connected correctly to the main board and connectors are connected securely to each speaker.
3. Check if SD card is plugged in correctly.

4. Check if files on the SD card are in top directory and have correct names (game\_sta.mp3, game1.mp3 - game5.mp3, winner.mp3).

## **Support videos**

For technical support videos please visit our [YouTube channel](#). You'll find there our most recent guide as well as older step-by-step tutorials.



## SUPPORT AND CONTACT INFORMATION

### World wide

#### **Kriss-Sport**

Rybnicka Street No. 34  
Żory (ZIP: 44-240), POLAND

#### **Office:**

fax: +48 32 43 42 328  
mail: [info@kriss-sport.com](mailto:info@kriss-sport.com)

#### **Manager:** Łukasz Bohosiewicz

phone: +48 50 17 45 222  
skype: lukasz\_bohosiewicz  
mail: [lukasz.bohosiewicz@gmail.com](mailto:lukasz.bohosiewicz@gmail.com)

#### **Technical support:** Krystian Stanik

phone: +48 60 15 21 140  
skype: kriss-sport-support  
mail: [support@kriss-sport.com](mailto:support@kriss-sport.com)



## WARRANTY TERMS

1. Kriss-Sport warrants that the machine will be free from defects in electronics (main board, power supply, wiring) and casing for a period of one year from the date of sale.
2. Buttons, button switches, CH923 coin acceptor, DG600F coin acceptor and Yenox ticket dispenser are covered with 3 months limited warranty.  
Comestero coin acceptor, WH coin acceptor and Entropy ticket dispenser are covered with 1 year limited producer warranty.
3. Warranty terms do not cover parts not included above.
4. Defect definition regarding casing: it will be considered as defective if un-welding or breaking takes place during warranty period. It does not include scratching or rubbing out of any metal part which results from heavy usage of the machine.

5. Defect definition regarding electronics: it will be considered as defective if any connection between subcomponents on a particular board fails or any of them stops working itself. It does not include damages which occurred due to misuse, unauthorized connection or modifications.
6. Kriss-Sport should be informed of the defect immediately after it occurred. The faulty part should be dispatched to Kriss-Sport as soon as possible.
7. Customer pays for shipping the part to Kriss-Sport.
8. Kriss-Sport pays for shipping the part back to customer only if the part is still covered by the warranty.
9. Kriss-Sport will diagnose that the defects were not caused by vandalism, improper use, neglect, unauthorized modifications, repair, setup or testing.
10. If the product prove defective during the warranty period, Kriss-Sport, at its option, shall:
  - a. Repair the defective part by means of telephone support or depot service at no charge for parts or labor.
  - b. Replace the defective part with a comparable product which may be new or refurbished.
11. Only parts recommended and approved by Kriss-Sport are covered by Kriss-Sport warranty terms.
12. Any unauthorized modifications will automatically void any existing warranty.
13. Under no circumstances shall Kriss-Sport be held of responsible for loses in profit, usage or accidental serious damage to the machine.

# COPYRIGHTS

This document is published under CC BY-NC-ND 3.0 license.

You are free to copy, distribute and transmit this document under the following conditions:

- Attribution — You must attribute the work in the manner specified by the author or licensor (but not in any way that suggests that they endorse you or your use of the work).
- Noncommercial — You may not use this work for commercial purposes.
- No Derivative Works — You may not alter, transform, or build upon this work.

© 2013 Kriss-Sport

[www.kriss-sport.com](http://www.kriss-sport.com)

[www.kriss-sportusa.com](http://www.kriss-sportusa.com)



