

Distributed by:

SEGA Amusements International Ltd.

Europe

Phone: +44 (0) 208 391 8090
Fax: +44 (0) 208 391 8099

United States of America

Phone: +1 (847) 364 9787
Fax: +1 (630) 860 7775
Email: sales@segaarcade.com
Web: www.segaarcade.com

E&OE (Errors & Omissions Excepted)

PIXEL CHASE

OWNER'S MANUAL

PIXEL CHASE

OWNER'S MANUAL



IMPORTANT

- Before using this product, read this manual carefully to understand the contents herein stated.
- After reading this manual, be sure to keep it near the product or in a convenient place for easy reference when necessary.

PRECAUTIONS BEFORE USE

The following safety precautions are given throughout this manual. They must be strictly followed to protect those who install, use or maintain this product as well as to protect players, visitors and property.

For safety reasons.

The following suggestions should be adhered to:

 **WARNING**
Disregarding could result in serious injury.

 **CAUTION**
Disregarding could result in injury or product damage.

The following graphic suggestions describe the types of precautions to be followed.

 Indicates that care should be taken.

 Indicates a matter which must be performed.

 Forbidden.

Certain procedures require a qualified in-shop maintenance person or industry specialist. For such instructions, a qualified person must take care of the jobs.

- Otherwise an electric shock, machine trouble, or a serious accident may result.
- Replacing the machine parts, inspecting and maintaining the machines, and troubleshooting must be assigned only to a qualified in-shop maintenance person or industry specialist. This booklet gives instructions that hazardous jobs in particular must be handled by an industry specialist. Qualified in-shop maintenance person and industry specialist are defined as follows.

Qualified in-shop maintenance person

- A service staff shall have experience in operations of game machines. The staff shall be responsible for assembly, installation, inspection and maintenance of the machine.

Industry specialist

- An industry specialist must be engaged in designing, manufacturing, inspecting and servicing amusement machines. He or she must have an education in electrical, electronic and mechanical engineering, and routinely maintain and repair amusement machines.

PRECAUTIONS FOR USE

WARNING

Be sure to consult an industry specialist when setting up, moving or transporting this product

- This product should not be set up, moved or transported by any one other than an industry specialist.
- When installing this product, set the 4 leg levelers evenly on the floor and make sure that the product is installed stably in injury or accident
- When installing this product, do not apply undue force on movable parts. Otherwise, injury and accident may result, or the product may be damaged.

This machine is for indoor use only. Do not install outside.



Do not place the machine near emergency exits.



Protect the machine from:

Rain or moisture.

Direct sunlight

Direct heat from air-conditioning and heating equipment, etc.

Hazardous flammable substances.

failure to observe these warnings may result in injury, accidental damage or malfunction.



Do not place containers holding chemicals or water on or near the machine.



Do not place object near the ventilating holes.



Do not bend the power cord or place heavy objects upon it.



Never connect or disconnect the power cord with wet hands.



Never remove the power by pulling the power cord, always use the power sw.



PRECAUTIONS FOR USE

CAUTION

Be sure to use indoor wiring within the specified voltage requirements. It is not recommended to use extension cables. If for some reason an extension cable must be used then please ensure that the rating of the extension cable matches that of the machine specifications or greater. Never use a multi-connection extension cable.

Be sure to use the attached power cord.



Do not lay the power cord where people walk through.



Be sure to ground this product.



Do not exert excessive force when moving the machine.



For proper ventilation, keep the machine at least 100mm (4") away from the walls.

Do not alter the system related dipswitch settings.

PRECAUTIONS FOR USE

CAUTION

If there is any abnormality such as smoke, bad smell or abnormal noise being emitted from the machine, immediately turn OFF the main power switch and unplug the power cord.



- Using the machine in abnormal conditions may result in a fire hazard or accidents.

In case of abnormality

1. Turn OFF the main power switch.
2. Unplug the power cord from the machine.
3. Contact your nearest dealer.

Do not leave the power cord plugged in incorrectly or covered with dust. 

Do not plug or unplug the power cord with wet hand. 

In handling the power cord, follow the instructions below. 

- Do not damage the power cord.
- Do not bend the power cord.
- Do not heat the power cord.
- Do not bind the power cord.
- Do not sandwich the power cord.
- Do not modify the power cord.
- Do not twist the power cord.
- Do not pull the power cord.
- Do not stand on the power cord.
- Do not drive a nail into the power cord.

If the power cord or power plug becomes damaged, stop using the machine immediately and ask your nearest dealer to replace the parts.

PRECAUTIONS FOR USE

CAUTION

Do not use this machine anywhere other than industrial areas.



- Using in a residential area or an area next to a residential area could affect signal reception of radios, television sets, telephones, etc.

When opening or closing the glass door, always hold the glass with one hand and move the door gently. If the glass door is opened or closed carelessly, your hand or fingers may get trapped or pinched or the glass may smash.

When moving the machine, do not push the glass section. Tempered glass is used but it can still smash if pressed hard. If the glass smashes, personal injury can occur to the player or bystanders.

For safety reasons, do not allow any of the following people to play the game.

- Those who have high blood pressure or heart problem.
- Those who are intoxicated or under the influence of drugs.
- Pregnant women.
- Those who are not in good health.
- Those who have experienced muscle convulsions or loss of consciousness when playing video games, etc.
- Even players who have never been adversely affected by light stimulus might experience dizziness or headache depending on their physical condition when playing the game.
- Those who have neck or spinal cord problems.

To avoid injury from falls and electric shock due to spilled drinks, instruct the player not to place items such as drinks on the machine.

To avoid electric shocks and short circuits, do not allow customers to put hands, fingers or extraneous matter into the openings of the machine or small opening in or around the doors.

To avoid falls and resulting injury, immediately stop the customer from leaning against or climbing upon the machine.

Instruct guardians of small children to keep an eye on their children at all times.

Children cannot sense danger. Allowing small children to get near a player who is playing the game may result in the child being bumped, stuck or knocked.

PRECAUTIONS FOR USE

WARNING

Be sure to turn OFF the main power switch and unplug the power cord from the product before inspecting or cleaning the machine.



When replacing parts, be sure to use parts of the correct specification. Never use parts other than those specified.



Opening inside the machine shall be done by a machine specialist or engineer qualified to do so as high current and voltages are present inside.



If the sub power switch of the service panel is turned OFF without turning OFF the main power switch of the power supply unit, some parts in the units remain live. When opening the back door, be sure to turn OFF the main power switch and unplug the power cord from the receptacle.



Strictly refrain from disassembly and repair of parts which are not indicated in this manual, as well as settings and remodeling.



To clean the game machine, wipe it with a soft cloth dampened in a neutral detergent.

- Using thinner or other organic solvent or alcohol may decompose the material.
- Electrical shock or equipment failure could be caused by water entering the inside of the machine.

CAUTION

Components in the game are sensitive to vibrations and impact. Care should be used when moving and transporting the game machine. Be sure not to let the machine tip over.

Before moving the machine, be sure to turn OFF the main power switch, unplug the power cord from the receptacle and remove the power cord from the machine.



Before moving take the machine, off the levelers and move it on the casters.



Avoid excessive force while moving the machine.

- When setting up, inspecting, maintaining, moving or transporting this product, follow the procedures and instructions set forth in this manual and perform such work safely.
- Do not set up, handle, inspect, maintain, move or transport this product under conditions equivalent to the condition of "WARNING" or "CAUTION" specified in this manual.
- If a new owner is to have this product as a result of transfer, etc., be sure to give this manual to the new owner.

 **WARNING**

Servicing and maintenance work of the contents herein stated should be performed by the SERVICEMAN stipulated as per IEC Standard. Those who do not have technical expertise and knowledge other than the SERVICEMAN are not allowed to perform the work herein stated. Executing aforementioned work by such non-technical personnel can cause serious accidents that may endanger life.

Parts replacement, maintenance inspections and troubleshooting should be carried out by site maintenance personnel or other qualified professionals. This manual includes directions for potentially dangerous procedures which should only be carried out by professionals with the appropriate specialised knowledge.

The site maintenance personnel or other qualified professionals mentioned in this manual are defined as follows:

Site maintenance personnel:

Individuals with experience in maintaining amusement equipment, vending machines, etc., working under the supervision of the owner/operator of this product to maintain machines within amusement facilities or similar premises by carrying out everyday procedures such as assembly, maintenance inspections, and replacement of units/expendable parts.

Activities to be carried out by site maintenance personnel:

Amusement equipment/vending machine assembly, maintenance inspection and replacement of units/expendable parts.

Other qualified professionals:

Persons employed by amusement equipment manufacturers, or involved in design, production, testing or maintenance of amusement equipment. The individual should have either graduated from technical school or hold similar qualifications in electrical/electronics/mechanical engineering.

Activities to be carried out by other qualified professionals:

Amusement equipment/vending machine assembly, repair/adjustment of electrical/electronic/mechanical parts.

Waste of Electrical and Electronic Equipment (WEEE) Statement.

The WEEE (Waste of Electrical and Electronic Equipment) directive places an obligation on all EU based manufacturers and importers of Electrical and Electronic Equipment to take back products at the end of their useful life. Sega Amusements Europe Ltd accepts its responsibility to finance the cost of treatment and recovery of redundant WEEE in the United Kingdom in accordance with the specified WEEE recycling requirements.

The symbol shown below will be on all products manufactured from 13th August 2005, which indicates this product must NOT be disposed of with other normal waste. Instead, it is the user's responsibility to dispose of their waste equipment by arranging to return it to a designated UK collection point for the correct recycling of waste electrical and electronic equipment.

For more information about where you can send your waste equipment for recycling contact your local authority office.

For non-UK users contact your local authority office for information on the recycling of Waste Electrical and Electronic Equipment.

Battery Recycling Statement.

The EC Directive on Batteries and Accumulators (2006/66/EC) aims to minimise the impact of batteries on the environment and encourage the recovery of the materials they contain. To achieve increased collection and recycling of waste batteries, the Directive places 'producer responsibility' obligations on manufacturers and importers of portable, industrial and automotive batteries.

The symbol shown below will be on all equipment fitted with batteries from 26th September 2008 and indicates they must NOT be disposed of with other normal waste. Instead, it is the user's responsibility to dispose of used batteries by arranging to return them to a designated collection point for the correct recycling.

For more information about where you can send your waste batteries for recycling contact your local authority office.



* Contents

1. SPECIFICATION AND DIMENSIONS (2p)	11 . ASSEMBLING PIXEL CHASE Ass'y (22p)
1-1. DIMENSIONS	11-1 AC POWER SWITCH Ass'y
1-2. SPECIFICATION	11-2 POWER SMPS Ass'y
	11-3 NOISE FILTER Ass'y
	11-4 PIXEL MAIN BOARD Ass'y
	11-5 CASH BOX Ass'y
2. Name of Parts & Label Location (3p)	11-6 CASH BOX BODY Ass'y
	11-7 FRONT TITLE ACRYL Ass'y
2-1 NAME OF PARTS	11-8 SCORE BOX BOTTOM LED Ass'y
2-2 STICKER LOCATION	11-9 SCORE PART FLEXIBLE Ass'y (RED)
	11-10 SCORE PART FLEXIBLE Ass'y (BLUE)
	11-11 SCORE PART FLEXIBLE Ass'y (GREEN)
	11-12 SCORE PART LIGHT Ass'y
3. COMPONENTS (4p)	11-13 SCORE PART LIGHT Ass'y _mir
	11-14 PIR SENSOR BASE Ass'y
	11-15 SCORE PART LIGHT CENTER Ass'y
	11-16 SPEAKER Ass'y
4. Function (5p)	11-17 SPEAKER Ass'y _ mir
4-1. Description of Switch of LCD Display Board	11-18 BALL DROP STOP OPERATION Ass'y
4-2. Sound Volume	11-19 BALL STOPPER DOOR BRKT Ass'y
4-3. Description of DIP Switch	11-20 SCORE BOX COVER Ass'y
	11-21 MIDDLE BALL PROTECT Ass'y
	11-22 SCORE FND BOX Ass'y
	11-23 TICKET BOX Ass'y
5. Menu Chart (6p)	11-24 FRONT MIDDLE DOOR ASSY
	11-25 FRONT SCORE TICKET Ass'y
	11-26 CREDIT FND Ass'y
	11-27 MIDDLE WOOD PANEL Ass'y
6 Setup Mode (7p)	11-28 MIDDLE SIDE ACRYL FRAME Ass'y
6-1. How to Setup	11-29 MIDDLE SIDE PANEL Ass'y
6-2. Game Mode	11-30 MIDDLE SIDE PANEL Ass'y _ mir
6-3. The no.of ticket to score range	11-31 PIXEL MODULE Ass'y
	11-32 REAR BALL REBOUND PROTECT Ass'y
	11-33 BILLBOARD SIDE UPPER BALL STOP Ass'y
	11-34 BILLBOARD SIDE UPPER BALL STOP Ass'y _ mir
	11-35 BILLBOARD BACK LIGHT Ass'y
7. Test MODE (15p)	11-36 BILLBOARD BACK LIGHT COVER Ass'y
7-1. How to Test Mode Setup	11-37 BILLBOARD CENTER Ass'y
7-2. Check the Status of Sensors and Switches.	11-38 BILLBOARD SIDE LIGHT ACRYL Ass'y (UP RED)
	11-39 BILLBOARD SIDE LIGHT ACRYL Ass'y (DOWN BLUE)
	11-40 BILLBOARD SIDE Ass'y
	11-41 BILLBOARD SIDE Ass'y _ mir
8. BOOKKEEPING & CLEAR mode (19p)	11-42 BILLBOARD BONUS FND Ass'y
8-1. How to get access to bookkeeping data	11-43 CASTER Ass'y
	11-44 CASTER Ass'y _ mir
	11-45 FRONT CABINET Ass'y
	11-46 FRONT CASE Ass'y
	11-47 FRONT CASE Ass'y
9. Errors (20p)	11-48 REAR CABINET Ass'y
	11-49 REAR CASE Ass'y
	11-50 REAR CASE Ass'y
10. TROUBLESHOOTING (21p)	11-51 ASSEMBLING PIXEL CHASE ALL FIX Ass'y
10-1. <Error Code "1">	
	12 . WIRE DIAGRAM (58p)
	13 . SHEET (63p)

1. SPECIFICATION AND DIMENSIONS

1-1. DIMENSIONS

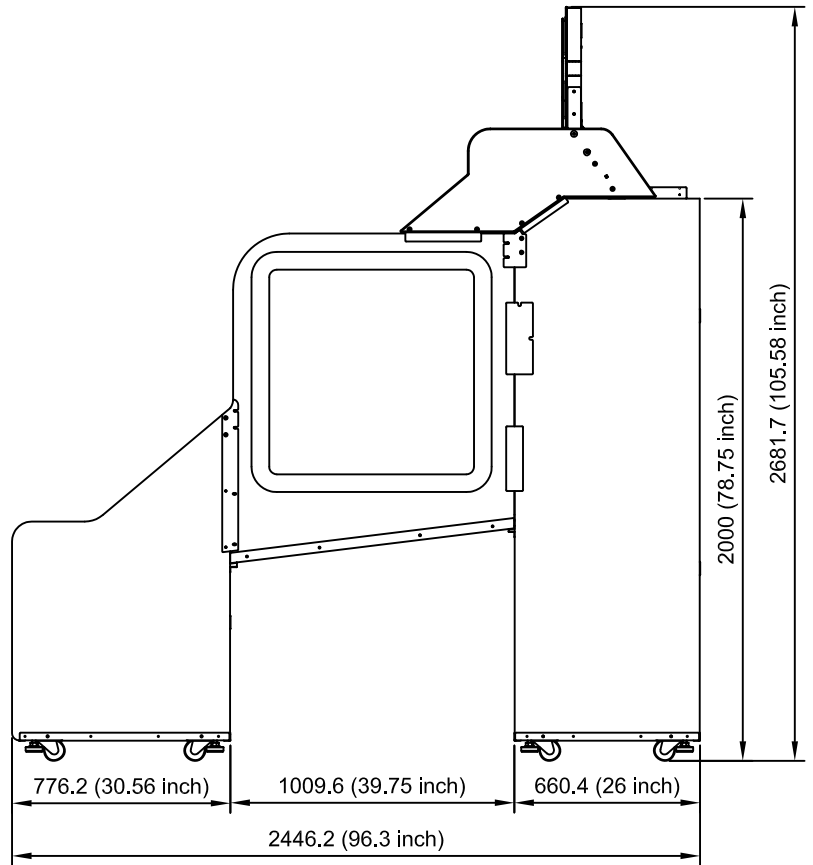
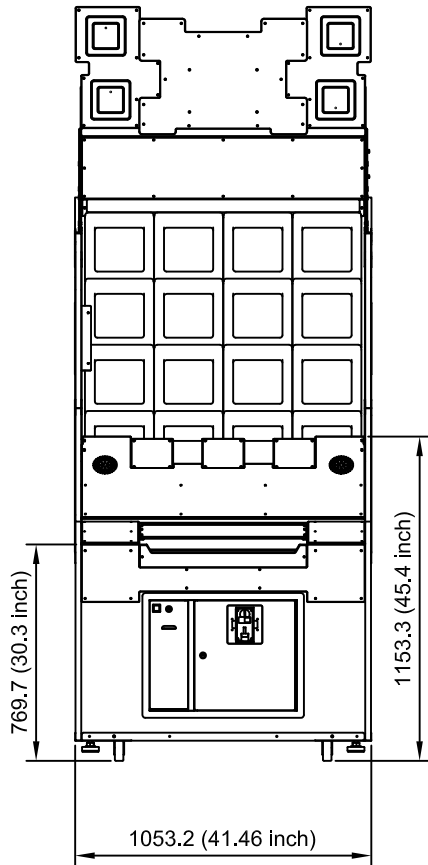

1-2. SPECIFICATION

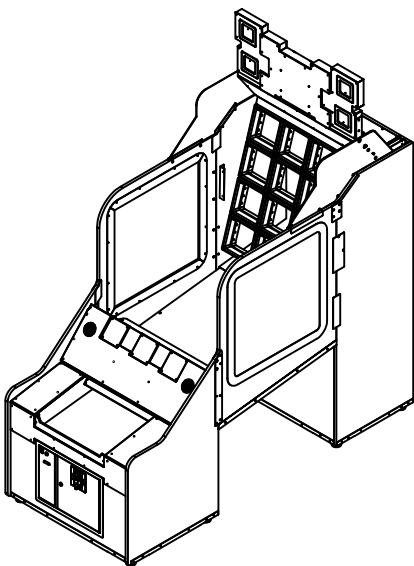

NOMINATED VOLTAGE RANGE	AC 120V	AC 230V
NOMINATED FREQUENCY RANGE	50Hz / 60Hz	50Hz / 60Hz
AVERAGE POWER CONSUMPTION	245W (2.1A)	245W (1.1A)
MAXIMUM POWER CONSUMPTION	285W (2.4A)	285W (1.3A)
WEIGHT	335Kg (738.6 lb)	335Kg (738.6 lb)

2. Name of Parts & Label Location

2-1. NAME OF PARTS

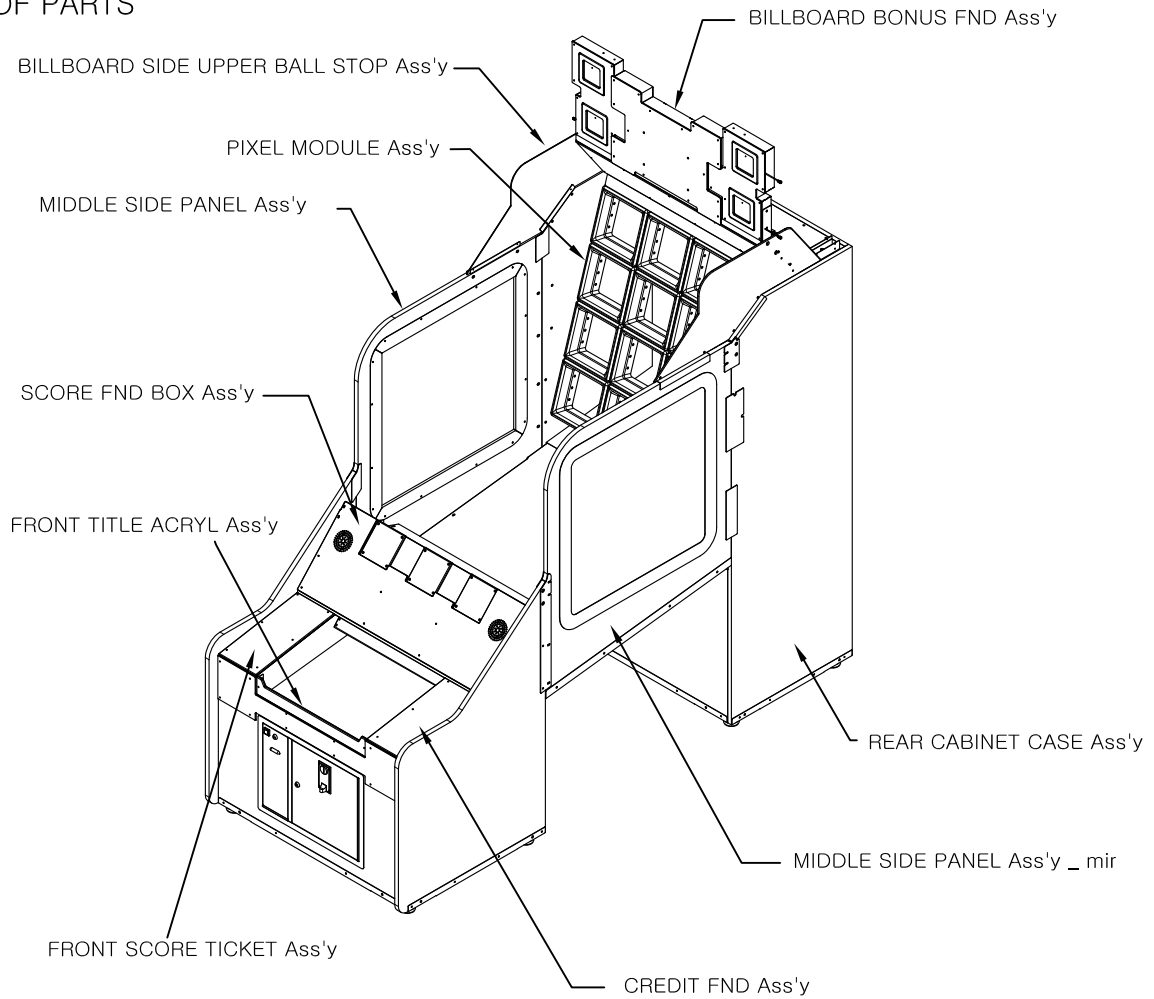

2-2. STICKER LOCATION

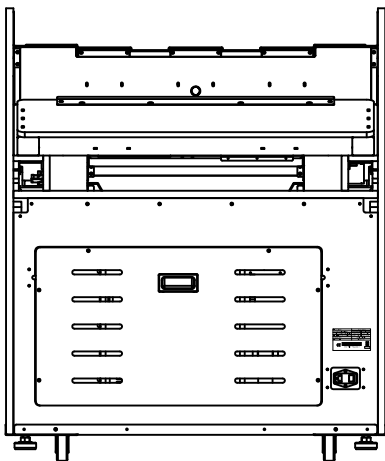

MODEL NAME	PIXEL CHASE	
	POWER REQUIREMENTS	AC 120V, 50-hz / 60-hz
AVERAGE POWER CONSUMPTION	245W (2.1A)	245W (1.1A)
MAXIMUM POWER CONSUMPTION	285W (2.4A)	285W (1.3A)
WEIGHT (KG)	335Kg (738.6 lb)	
MODEL NO.	KM-PIX-001	

KM-PIX-1800001

3. COMPONENTS

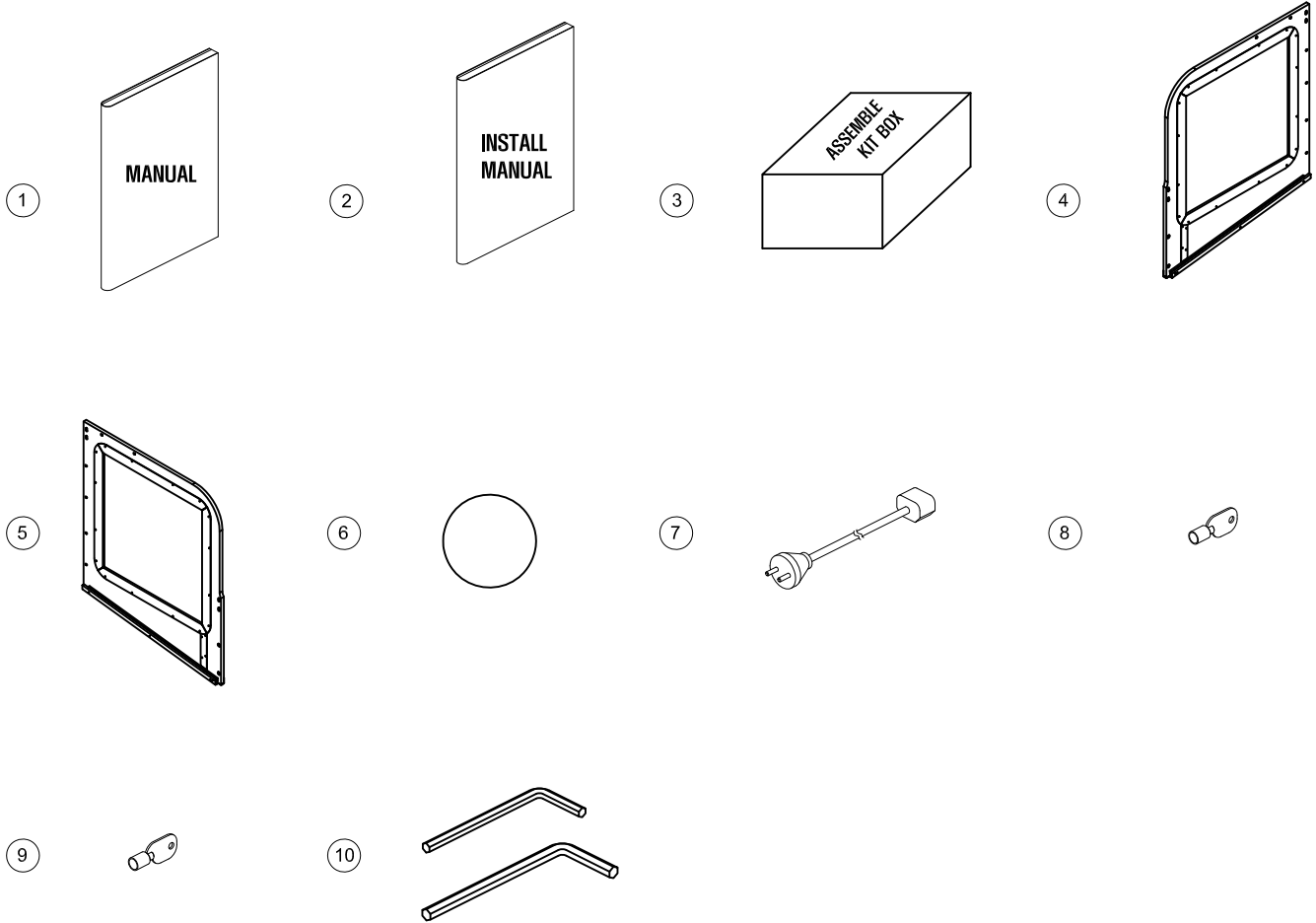

* Key, AC POWER CORD, WRENCH are inserted in the ASSEMBLY KIT BOX.

NO.	PART NAME	SPEC.	QUANTITY	CODE NO.
1	MANUAL	PIXEL CHASE	1	MPIXOMAN001
2	INSTALL MANUAL	PIXEL CHASE	1	MPIXOMAN002
3	ASSEMBLY KIT BOX	BOX	1	
4	MIDDLE SIDE PANEL Ass'y	ASSEMBLE (조립품)	1	APIXOASM026
5	MIDDLE SIDE PANEL Ass'y_mir	ASSEMBLE (조립품)	1	APIXOASM027
6	BALL (φ 75)	φ 75	50EA	MPIXOBAL001
7	AC POWER CORD (3M)	125V-7A(0.75)	1	MELEOACP001
		250V-10A(0.75)		MELEOACP008
		250V-13A(0.75)UL (BF3)		MELEOACP006
8	DOOR KEY / TICKET BOX KEY	7001	2	MZZZOKEY032
9	CASH BOX KEY	6001	2	MZZZOKEY013
10	WRENCH	3mm	1EA	MXXXOREN004
		4mm		MXXXOREN002

RECOMMENDATION

Please put the appropriate number of balls into the machine to let players enjoy the game.

The recommended number of balls is 15, but you can adjust the quantity for the needs of your operation.

4. Function

4-1. Description of Switch of LCD Display Board

(LCD Display Board)

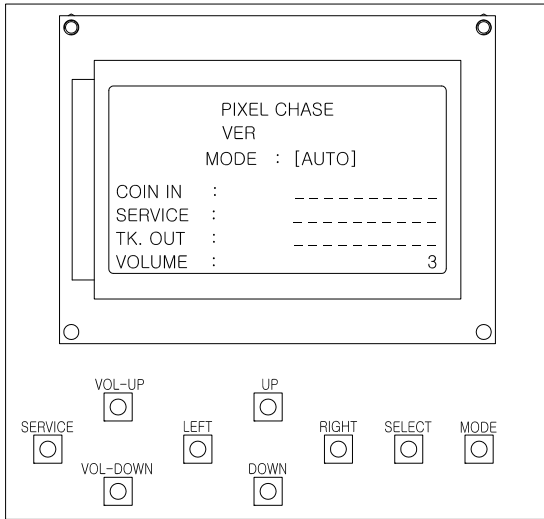

- 1) [Service] : Service Credit
- 2) [Vol-Up /Down] : To adjust Volume
- 3) [Up / Down] : To move up or Down in the menu / To adjust setup value
- 4) [Left / Right] : To move a cursor Right or Left to change a figure
A figure blinks when a cursor moves.
- 5) [Select] : To Select / Enter into the Menu
- 6) [Mode] : To exit or return to upper menu

4-2. Sound Volume

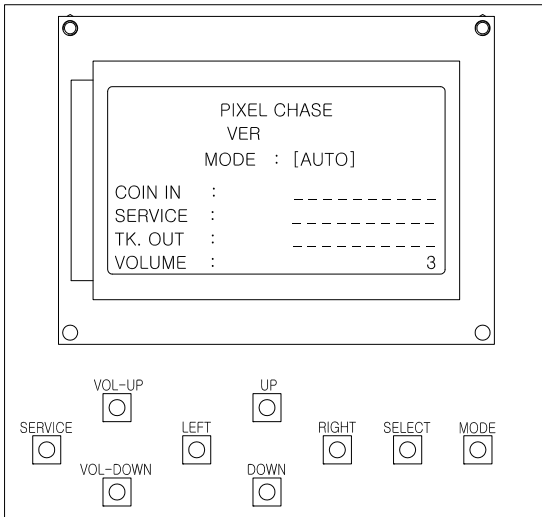

Volume Range : 0~7

4-3. Description of Dip Switch

(MAIN BOARD DIP SW)

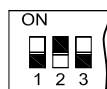
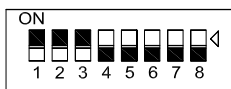

- ➔ BLACK UP = ON
- ➔ BLACK DOWN = OFF

ON : fun game (no tickets)
OFF : Ticket game

Pattern No.0~9

5. Menu Chart

* Press MODE button for 3 sec to enter Menu List

Push UP/DOWN button to move up or down in the menu list and press SELECT button.

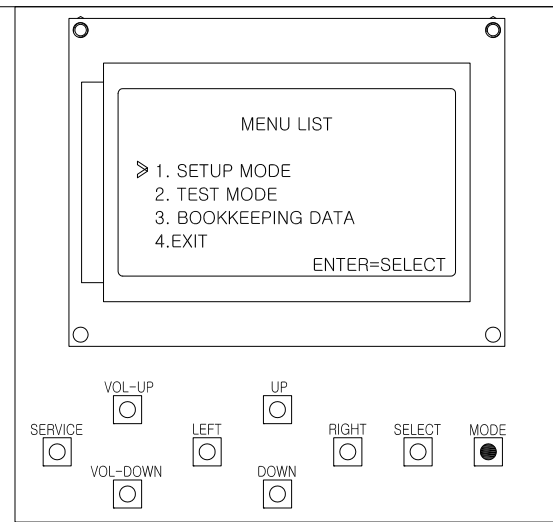
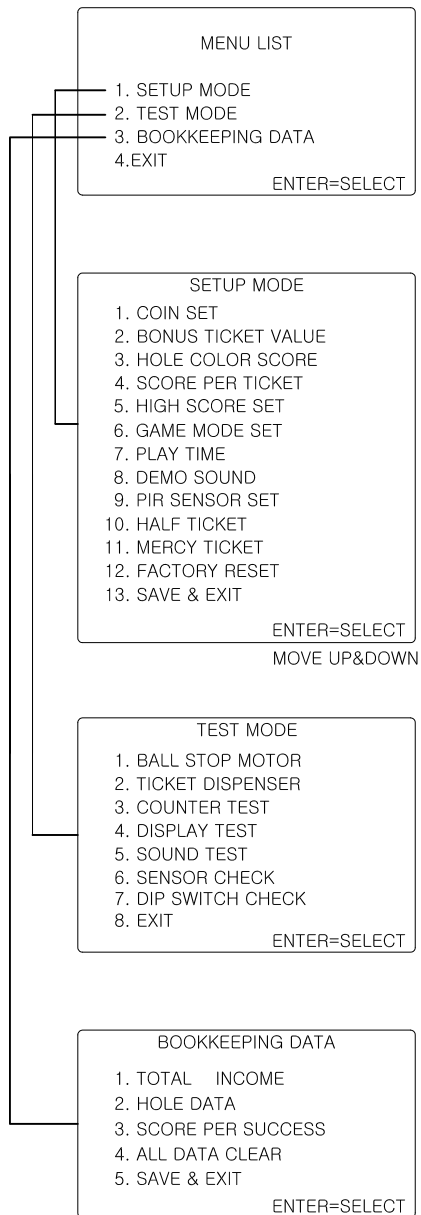

6. Setup Mode

* This mode allow Game Setting to be modified for Operation of the Game Machine.

6-1. How to Setup.

- 1) Press MODE button for 3 sec to enter Menu List
- 2) Push UP/DOWN button to move to the setup mode and press SELECT button.
- 3) Push UP/DOWN button to move up or down in the setup menu and press SELECT button.
- 4) Press UP/DOWN button to move a cursor. / Push LEFT/RIGHT to change a figure.

(A figure blinks when a cursor is moved.)

- 5) Press Mode button to move to upper menu.

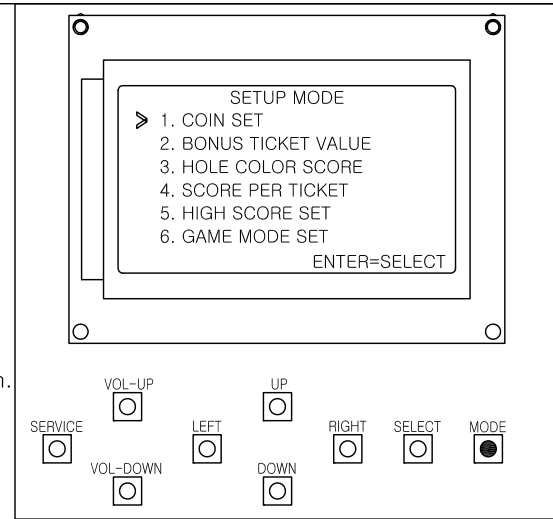

```

SETUP MODE
1. COIN SET
FREE PLAY : OFF
[ 4 ] COIN      1 CREDIT
EXIT = MODE KEY
    
```

Price per play (Set the no. of Coins)

Range : 0~20

Default : 4 Coin / 1 Credit

Unit : 1 Coin / 1 credit

0 COIN: Free Play Mode

```

SETUP MODE
2. BONUS TICKET VALUE
ACCUMULATED : [ 0 ]
START VALUE : [ 500 ]
END VALUE : [ 500 ]
EXIT = MODE KEY
    
```

No. of accumulated Bonus per credit/game

Accumulated : No. of tickets accumulated per game

Range : 0~10 Default : 0 Unit : 1 0 : NONE.

Start Value : Bonus ticket start value on Bonus FND

Range : 0~1000 Unit : 1

End Value : Maximum bonus ticket value

Range : 0~1000 Unit : 1

* Range of end value changes in accordance with value setting of Start Value.

* Numbers keep going up while holding Left or Right button.

```

SETUP MODE
3. HOLE COLOR SCORE
BLUE COLOR : [ 500 ]
GREEN COLOR : [ 700 ]
RED COLOR : [ 1000 ]
EXIT = MODE KEY
    
```

HOLE COLOR SCORE

BLUE - Range : 1~1000 Default : 500

GREEN - Range : 1~1000 Default : 700

RED - Range : 1~1000 Default : 1000

Unit : 1

```

SETUP MODE
4. SCORE PER TICKET
[45100] = 80TK
[35100]~[45000] = 60TK
[25100]~[35000] = 40TK
[15100]~[25000] = 30TK
[10100]~[15000] = 20TK
[ 100]~[10000] = 10TK
EXIT = MODE KEY
    
```

TICKETS PER SCORE (Change score range or ticket value)

SCORE — Range : 100~99,900

Unit : 100

TICKET — Range : 1~999

Unit : 1

<How to change a figure>

When you enter the tickets per score menu, the score range blinks. Change range using Left/Right button. If you want to change quantity of the tickets, move to Ticket using Up/Down button and press Select button. Change no. of ticket per score range using Left/Right button.

```

SETUP MODE
5. HIGH SCORE SET
HIGH SCORE : [ 65,000 ]
HIGH SCORE RST : [ 200 ]
HIGH SCORE FREE GAME : [ 1 ]
EXIT = MODE KEY
    
```

HIGH SCORE SET (To set the Highest Score to win Bonus)

HIGH SCORE — Range : 10,000~80,000

Default : 65,000

Unit : 500

HIGH SCORE RESET — Range : 0~500

Default : 200

Unit : 1

HIGH SCORE FREE GAME — Range : [1], [OFF]

No of accumulated game play to reset the highest score.

When it is reached, the highest score is reset and changed to high score default value.

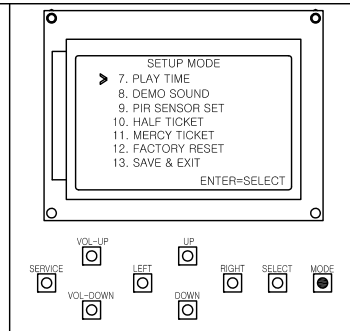

SETUP MODE
6. GAME MODE SET

MODE : [AUTO]

EXIT = MODE KEY

GAME MODE SETTING

Range : [TORNADO] , [SPIN] , [CHANGE] , [DROP] . [AUTO]
Default : [AUTO]

<How to change Game Mode>

Enter the Game Mode set and change MODE pressing Left/Right button.

SETUP MODE
7. PLAY TIME

[30] sec

EXIT = MODE KEY

Play time per credit

Range : 10~60
Default : 30 sec
Unit : 1

SETUP MODE
8. DEMO SOUND

[5] MIN

EXIT = MODE KEY

Demo sound ON/OFF

Range : (Off) , (1 ~ 10 MIN) , (Always)
Default : 5 MIN
Unit : 1

SETUP MODE
9. PIR SENSOR SET

[OFF] CHECK

EXIT = MODE KEY

Set sensor detection frequency.

Range : (OFF) , (1 ~ 10)
Default : OFF
Unit : 1

* When the sensor is detected up to the set number of times, it makes alarm sound and forfeits the game.

SETUP MODE
10. HALF TICKET

[0]

EXIT = MODE KEY

Ticket Value (Half Ticket Option)

Range : (0) Normal , (1) Half
Default : 0
Unit : 1

SETUP MODE
11. MERCY TICKET

[0]

EXIT = MODE KEY

Mercy Ticket

Range : (0 ~ 10)
Default : 0
Unit : 1

SETUP MODE
12. FACTORY RESET

YES NO

Clear the all setup value and return to default setting

SETUP MODE
13. SAVE & EXIT

YES NO

Save&Exit or Exit without saving

YES : Save&Exit
NO : Exit without saving

6-2. Game Mode.

*TORNADO

The specific pattern (2xRED hole, 3xGreen hole order) lighting moves in a square spiral shape
 When the ball enters the hole, the movement of lighting stops for a while. (About 3 sec)

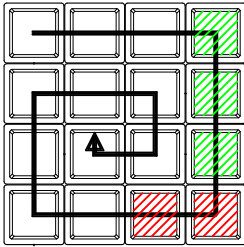

*SPIN

As shown in the drawing below, the lighting color pattern rotates within 2x2 target holes for every 5 seconds.

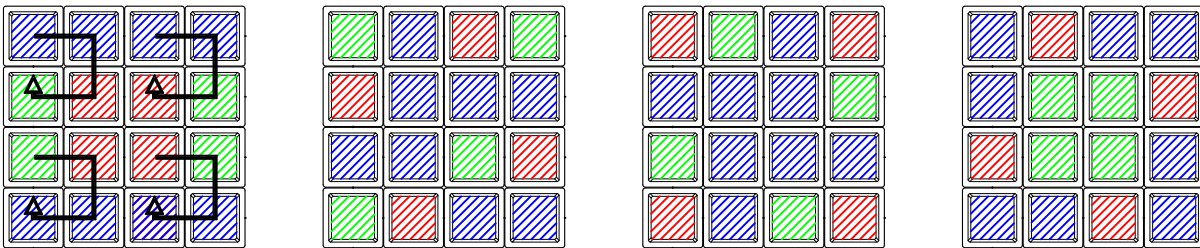

*CHANGE

As shown in the drawing below, the lighting color pattern changes every 5 seconds.

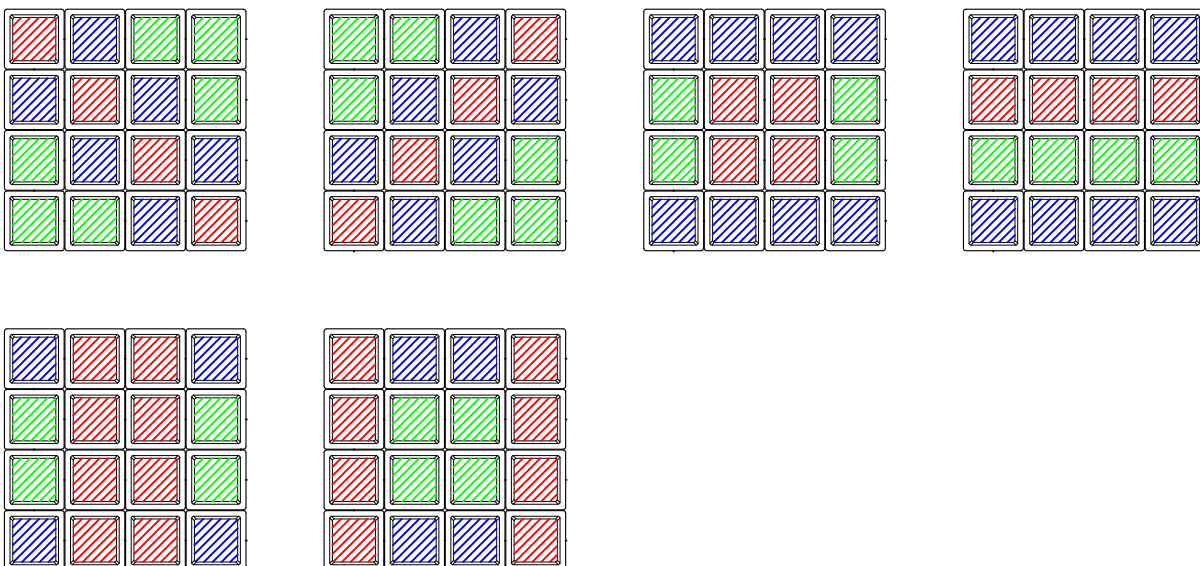

*DROP

RED color pixels are shifted downward row by row

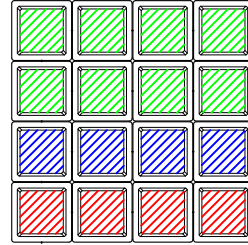
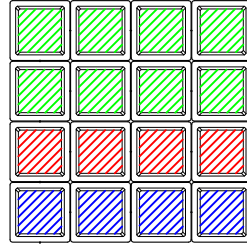
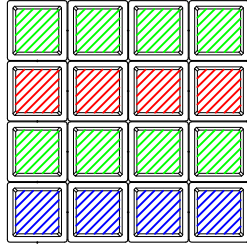
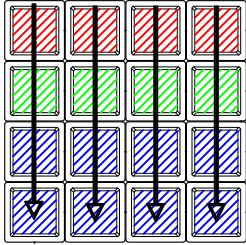

*AUTO

4 different game patterns rotate

6-3. The no.of ticket to score range

Setup Example #0 CEC

Set DIP switch to :
P0
(MAIN BOARD DIP SW)

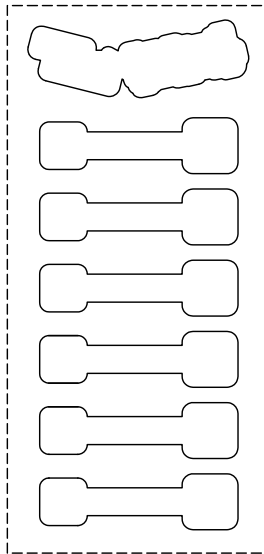
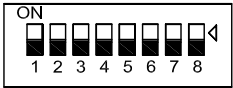

→	BONUS	→	
→	OVER 45,100	→	10 Ticket
→	35,100 ~ 45,000	→	6 Ticket
→	25,100 ~ 35,000	→	4 Ticket
→	15,100 ~ 25,000	→	3 Ticket
→	10,100 ~ 15,000	→	2 Ticket
→	100 ~ 10,000	→	1 Ticket

Set 'Bonus' to maximum of :

50

Setup Example #1

Set DIP switch to :
P1
(MAIN BOARD DIP SW)

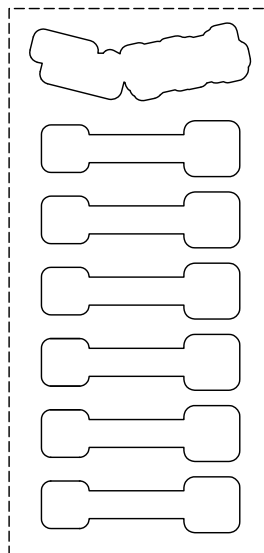

→	BONUS	→	
→	OVER 45,100	→	20 Ticket
→	35,100 ~ 45,000	→	10 Ticket
→	25,100 ~ 35,000	→	8 Ticket
→	15,100 ~ 25,000	→	6 Ticket
→	10,100 ~ 15,000	→	4 Ticket
→	100 ~ 10,000	→	2 Ticket

Set 'Bonus' to maximum of :

100

Setup Example #2

Set DIP switch to :
P2
(MAIN BOARD DIP SW)

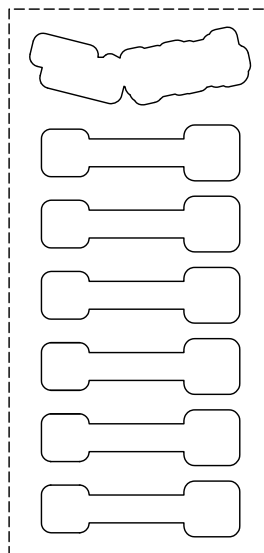
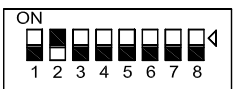

→	BONUS	→	
→	OVER 45,100	→	30 Ticket
→	35,100 ~ 45,000	→	20 Ticket
→	25,100 ~ 35,000	→	15 Ticket
→	15,100 ~ 25,000	→	10 Ticket
→	10,100 ~ 15,000	→	8 Ticket
→	100 ~ 10,000	→	6 Ticket

Set 'Bonus' to maximum of :

250

Setup Example #3

Set DIP switch to :
P3
(MAIN BOARD DIP SW)

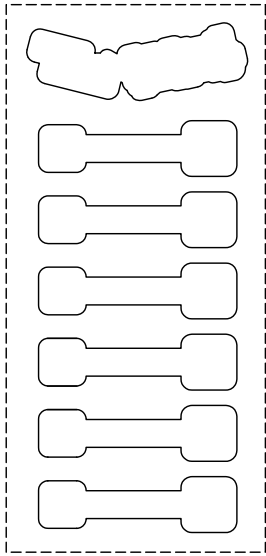
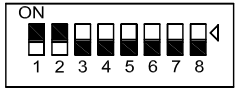

→	BONUS	→	
→	OVER 45,100	→	40 Ticket
→	35,100 ~ 45,000	→	30 Ticket
→	25,100 ~ 35,000	→	20 Ticket
→	15,100 ~ 25,000	→	15 Ticket
→	10,100 ~ 15,000	→	10 Ticket
→	100 ~ 10,000	→	6 Ticket

Set Bonus' to maximum of :

250

Setup Example #4

Set DIP switch to :
P4
(MAIN BOARD DIP SW)

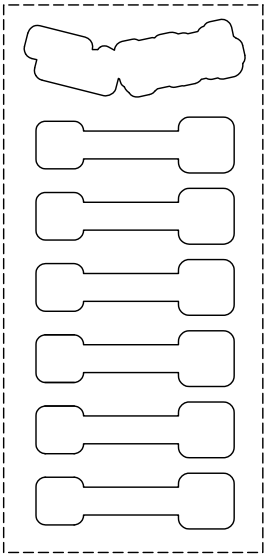
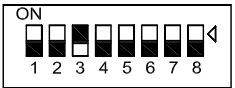

→	BONUS	→	
→	OVER 45,100	→	50 Ticket
→	35,100 ~ 45,000	→	40 Ticket
→	25,100 ~ 35,000	→	25 Ticket
→	15,100 ~ 25,000	→	15 Ticket
→	10,100 ~ 15,000	→	10 Ticket
→	100 ~ 10,000	→	8 Ticket

Set Bonus' to maximum of :

250

Setup Example #5

Set DIP switch to :
P5
(MAIN BOARD DIP SW)

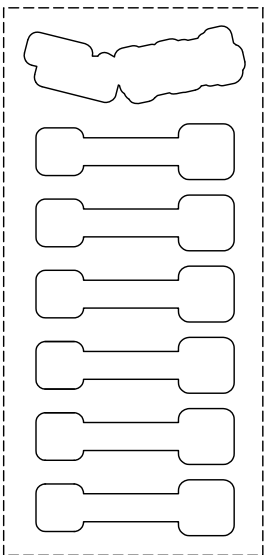
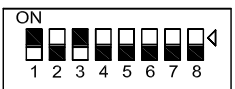

→	BONUS	→	
→	OVER 45,100	→	70 Ticket
→	35,100 ~ 45,000	→	50 Ticket
→	25,100 ~ 35,000	→	30 Ticket
→	15,100 ~ 25,000	→	20 Ticket
→	10,100 ~ 15,000	→	15 Ticket
→	100 ~ 10,000	→	10 Ticket

Set Bonus' to maximum of :

500

Setup Example #6

Set DIP switch to :
P6
(MAIN BOARD DIP SW)

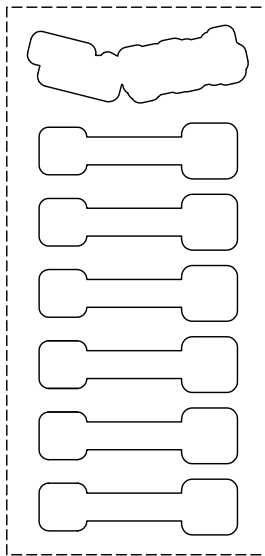
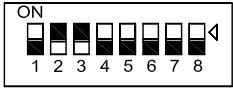

→	BONUS	→	
→	OVER 45,100	→	70 Ticket
→	35,100 ~ 45,000	→	50 Ticket
→	25,100 ~ 35,000	→	35 Ticket
→	15,100 ~ 25,000	→	20 Ticket
→	10,100 ~ 15,000	→	15 Ticket
→	100 ~ 10,000	→	10 Ticket

Set Bonus' to maximum of :

500

Setup Example #7

Set DIP switch to :
P7
(MAIN BOARD DIP SW)

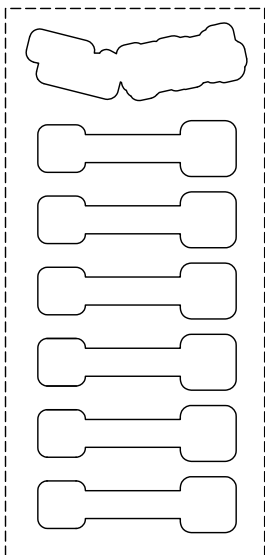

→	BONUS	→	
→	OVER 45,100	→	80 Ticket
→	35,100 ~ 45,000	→	60 Ticket
→	25,100 ~ 35,000	→	40 Ticket
→	15,100 ~ 25,000	→	30 Ticket
→	10,100 ~ 15,000	→	20 Ticket
→	100 ~ 10,000	→	10 Ticket

Set Bonus' to maximum of :

500

Setup Example #8

Set DIP switch to :
P8
(MAIN BOARD DIP SW)

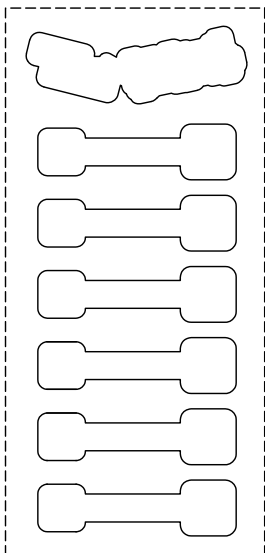
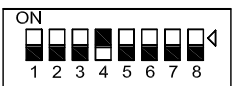

→	BONUS	→	
→	OVER 45,100	→	100 Ticket
→	35,100 ~ 45,000	→	70 Ticket
→	25,100 ~ 35,000	→	40 Ticket
→	15,100 ~ 25,000	→	30 Ticket
→	10,100 ~ 15,000	→	20 Ticket
→	100 ~ 10,000	→	10 Ticket

Set Bonus' to maximum of :

500

Setup Example #9

Set DIP switch to :
P9
(MAIN BOARD DIP SW)

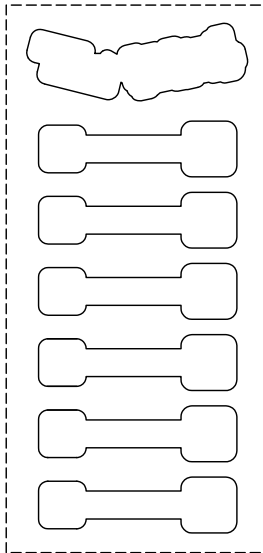

→	BONUS	→	
→	OVER 45,100	→	130 Ticket
→	35,100 ~ 45,000	→	100 Ticket
→	25,100 ~ 35,000	→	60 Ticket
→	15,100 ~ 25,000	→	40 Ticket
→	10,100 ~ 15,000	→	30 Ticket
→	100 ~ 10,000	→	20 Ticket

Set Bonus' to maximum of :

500

Setup Example #10

Set DIP switch to :
P10
(MAIN BOARD DIP SW)

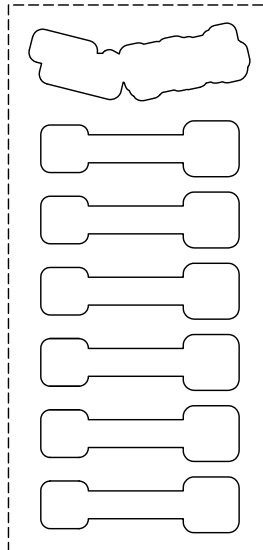

→	BONUS	→	
→	OVER 45,100	→	200 Ticket
→	35,100 ~ 45,000	→	150 Ticket
→	25,100 ~ 35,000	→	100 Ticket
→	15,100 ~ 25,000	→	70 Ticket
→	10,100 ~ 15,000	→	50 Ticket
→	100 ~ 10,000	→	30 Ticket

Set Bonus' to maximum of :

500

Setup Example #11

Set DIP switch to :
P11
(MAIN BOARD DIP SW)

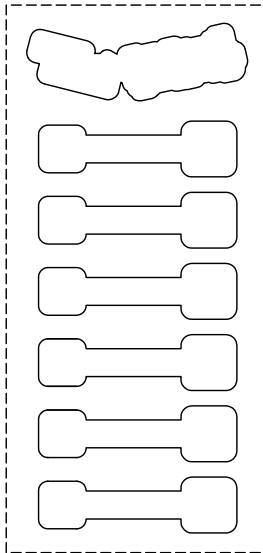

→	BONUS	→	
→	OVER 45,100	→	10 Ticket
→	35,100 ~ 45,000	→	6 Ticket
→	25,100 ~ 35,000	→	4 Ticket
→	15,100 ~ 25,000	→	3 Ticket
→	10,100 ~ 15,000	→	2 Ticket
→	100 ~ 10,000	→	1 Ticket

Set Bonus' to maximum of :

50

Setup Example #12

Set DIP switch to :
P12
(MAIN BOARD DIP SW)

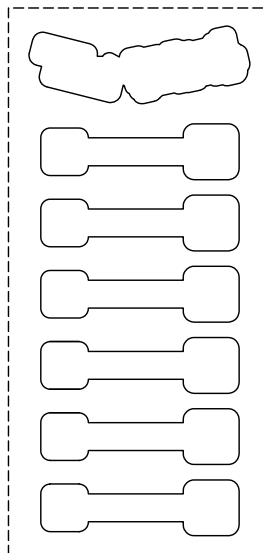

→	BONUS	→	
→	OVER 45,100	→	10 Ticket
→	35,100 ~ 45,000	→	8 Ticket
→	25,100 ~ 35,000	→	6 Ticket
→	15,100 ~ 25,000	→	5 Ticket
→	10,100 ~ 15,000	→	4 Ticket
→	100 ~ 10,000	→	3 Ticket

Set Bonus' to maximum of :

50

Setup Example #13

Set DIP switch to :
P13
(MAIN BOARD DIP SW)

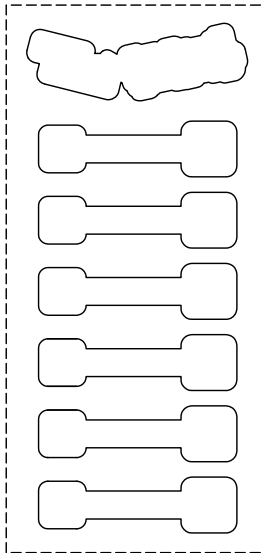
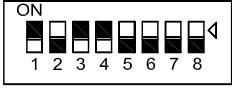

→	BONUS	→	
→	OVER 45,100	→	10 Ticket
→	35,100 ~ 45,000	→	8 Ticket
→	25,100 ~ 35,000	→	7 Ticket
→	15,100 ~ 25,000	→	6 Ticket
→	10,100 ~ 15,000	→	5 Ticket
→	100 ~ 10,000	→	4 Ticket

Set Bonus' to maximum of :

50

Setup Example #14

Set DIP switch to :
P14
(MAIN BOARD DIP SW)

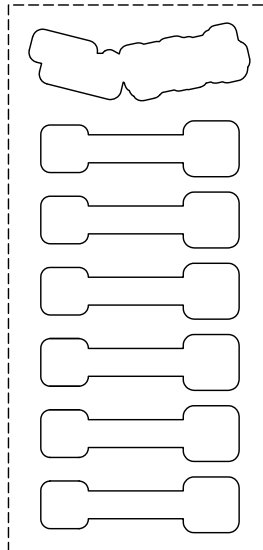
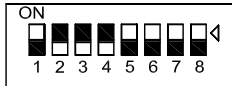

→	BONUS	→	
→	OVER 45,100	→	12 Ticket
→	35,100 ~ 45,000	→	10 Ticket
→	25,100 ~ 35,000	→	8 Ticket
→	15,100 ~ 25,000	→	6 Ticket
→	10,100 ~ 15,000	→	5 Ticket
→	100 ~ 10,000	→	4 Ticket

Set Bonus' to maximum of :

50

7. Test Mode

7-1. How to Test Mode Setup

- 1) Press MODE button for 3 sec to enter Menu List.
- 2) Press UP or DOWN button to move to TEST mode and push SELECT button.
- 3) Press UP or DOWN button to move to test menu and push SELECT button.
- 4) Conduct testing according to instruction.
- 5) Press MODE button to return to upper menu or mode

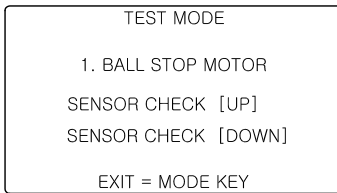
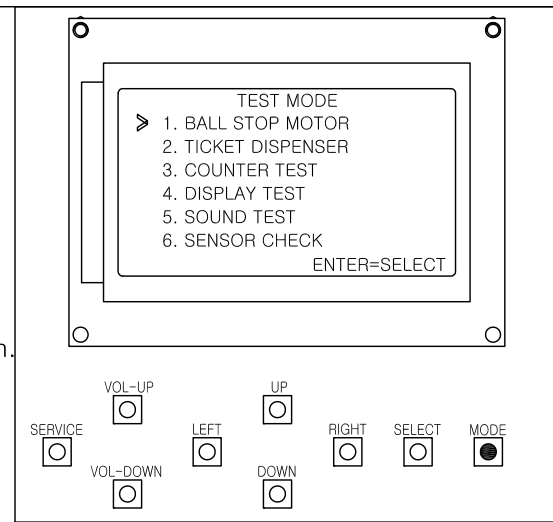

BALL STOP Motor Test

Press and hold RIGHT button to run BALL STOP motor.

- * SENSOR CHECK [UP] : Ball stop gate is open
- SENSOR CHECK [DOWN] : Ball stop gate is closed.

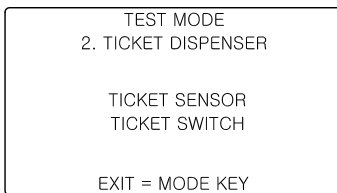

Ticket Dispenser Test

Press SELECT button to run Ticket Dispenser.

'Ticket Switch' is blinking whenever pushing Ticket Button.

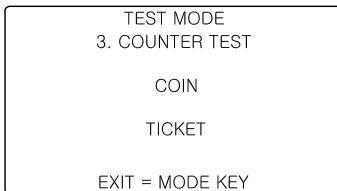

Counter Test

Push LEFT or RIGHT button to move and run counters.

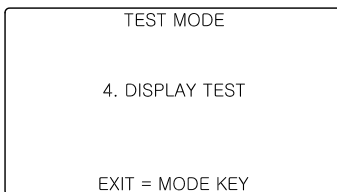

LED Display Test

Press SELECT button to do display test.

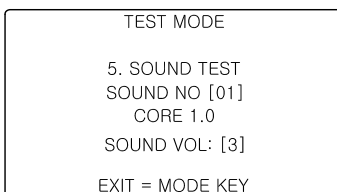

Sound Test

It plays next sound effect once Left/Right button is pressed.

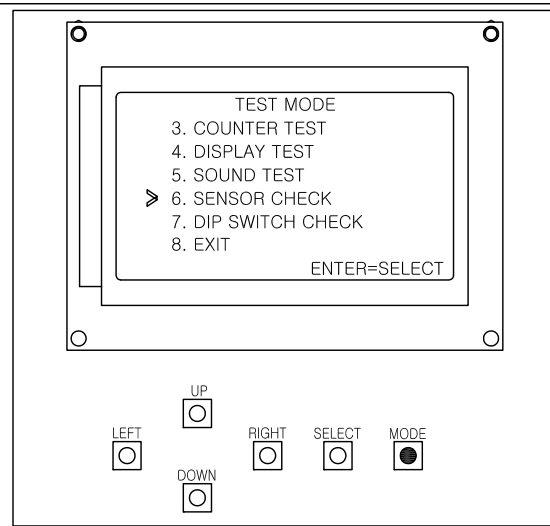

```

TEST MODE
6. SENSOR CHECK
01 02   03 04   05 06   07 08
09 10   11 12   13 14   15 16
T1SB   CO12   BMUS   BMDS
PIRS
EXIT = MODE KEY

```

To test operating status of the Sensors (refer to page 17, 18.)

```

TEST MODE
7.DIP SWITCH CHECK

1 1 1 0 0 0 0 0

```

Dip Switches

To check On/Off status of DIP switches of main board

0 = Off
1 = On

```

TEST MODE

8. EXIT

```

Exit test mode

7-2. Check the Status of Sensors and Switches.

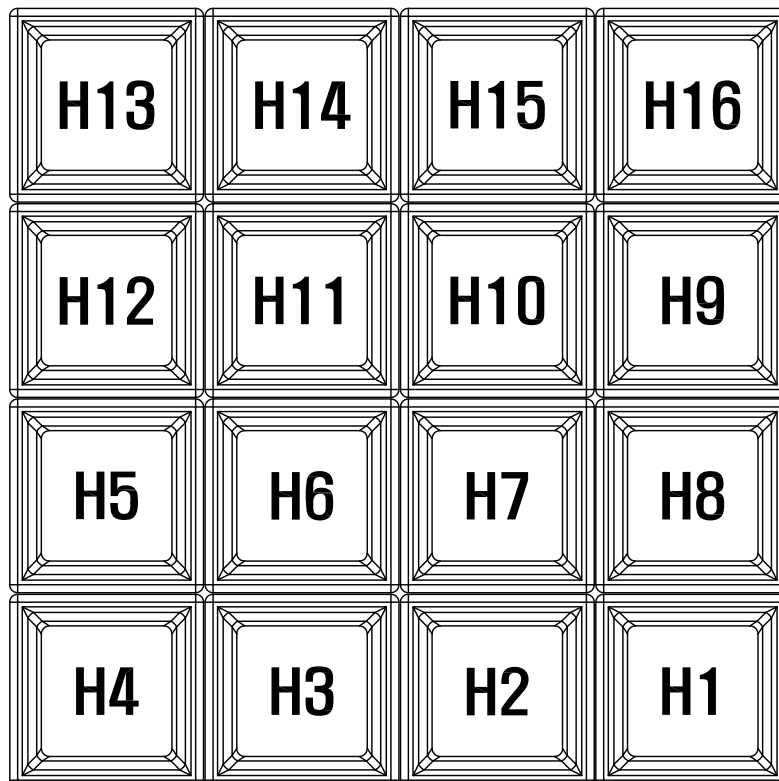
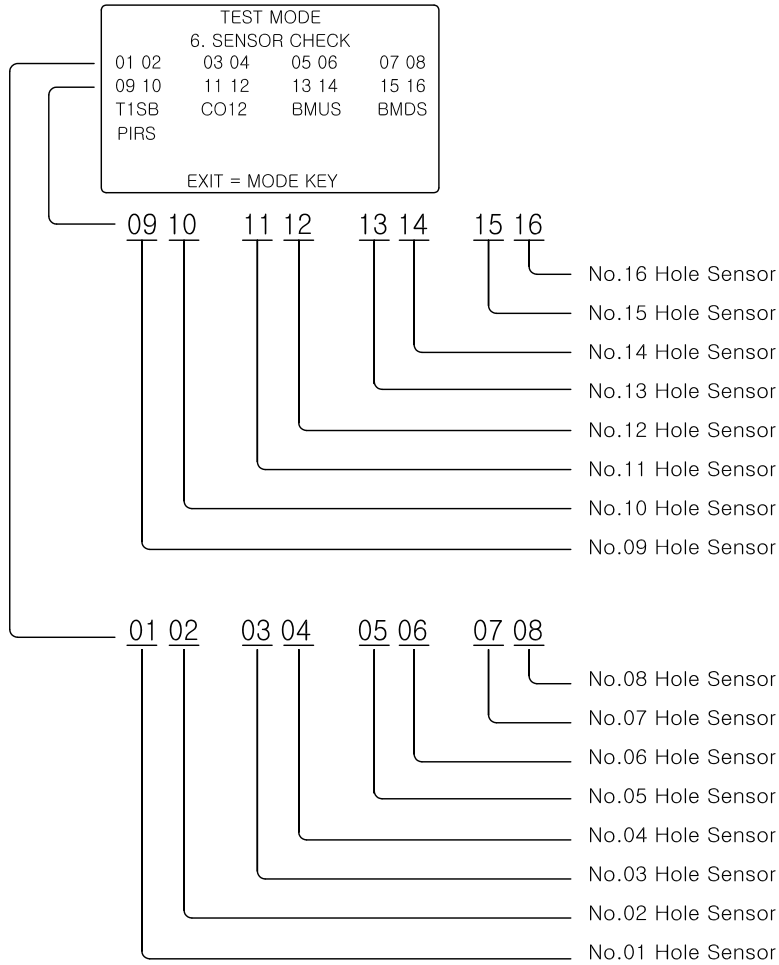

TEST MODE			
6. SENSOR CHECK			
01 02	03 04	05 06	07 08
09 10	11 12	13 14	15 16
T1SB	CO12	BMUS	BMDS
PIRS			
EXIT = MODE KEY			

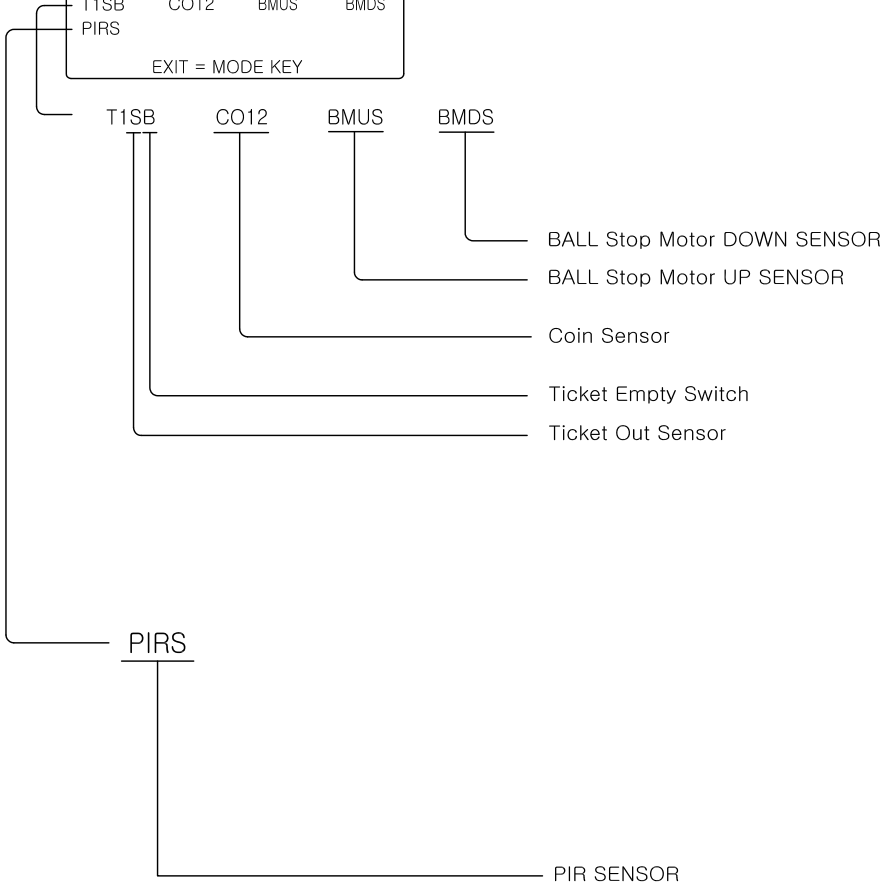

8. BOOKKEEPING & CLEAR mode

* This mode allows Bookkeeping Data management related to income and payout

8-1. How to get access to bookkeeping data

- 1) Press MODE button for 3 sec to enter Menu List.
- 2) Press UP or DOWN button to move to Bookkeeping Data and push SELECT button.
- 3) Press UP or DOWN button to move to data menu and push SELECT button.
- 4) Press MODE button to return to upper menu or mode

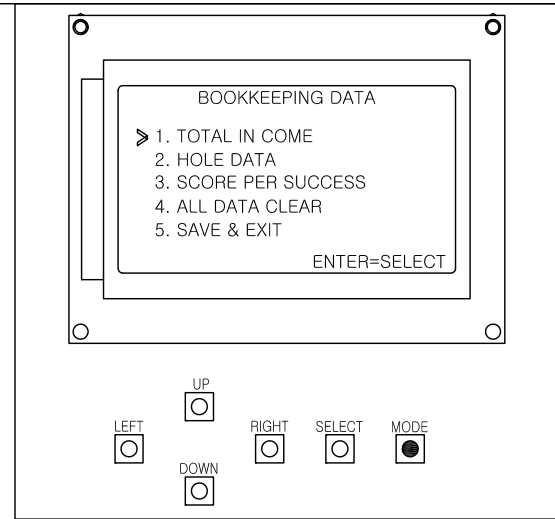

BOOKKEEPING DATA
1. TOTAL INCOME

COIN IN [_ _ _ _ _]
TICKET [_ _ _ _ _]
SERVICE [_ _ _ _ _]

EXIT = MODE KEY

Total Income

Coin In : Total Coin accumulated income

Ticket Out : Total Tickets dispensed

Service : Total Service credit

BOOKKEEPING DATA
2. HOLE DATA

H01[_ _ _ _] H02[_ _ _ _]
H03[_ _ _ _] H04[_ _ _ _]
H05[_ _ _ _] H06[_ _ _ _]
H07[_ _ _ _] H08[_ _ _ _]
H09[_ _ _ _] H10[_ _ _ _]
H11[_ _ _ _] H12[_ _ _ _]
H13[_ _ _ _] H14[_ _ _ _]
H15[_ _ _ _] H16[_ _ _ _]

Hole No

Number of times a ball entered each hole.

Clear data : Press and hold SELECT button..

Press DOWN button to move to next Hole Data.

BOOKKEEPING DATA
3. SCORE PER SUCCESS

BONUS = [_ _ _ _]
F = [_ _ _ _]
E = [_ _ _ _]
D = [_ _ _ _]
C = [_ _ _ _]
B = [_ _ _ _]
A = [_ _ _ _]

Number of times per each score range

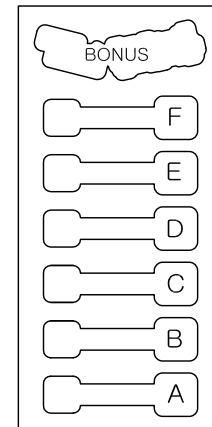

Up and Down Move

BOOKKEEPING DATA
4. ALL DATA CLEAR

YES NO

Clear the all bookkeeping data

BOOKKEEPING DATA
5. SAVE & EXIT

YES NO

Save&Exit or Exit without saving.

YES : Save&Exit

NO : Exit without saving

9. Errors

HIGH SCORE FND



— Error on Ball Stop Sensor or Ball Stop Motor

10. Trouble Shooting

TEST MODE

1. BALL STOP MOTOR
SENSOR CHECK (UP)
SENSOR CHECK (DOWN)

EXIT = MODE KEY

10-1. <Error Code "1">

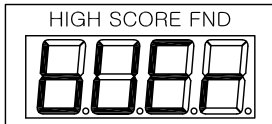

Ball STOP Motor Sensor

- When the motor doesn't operate or the sensor doesn't work after a certain period of time

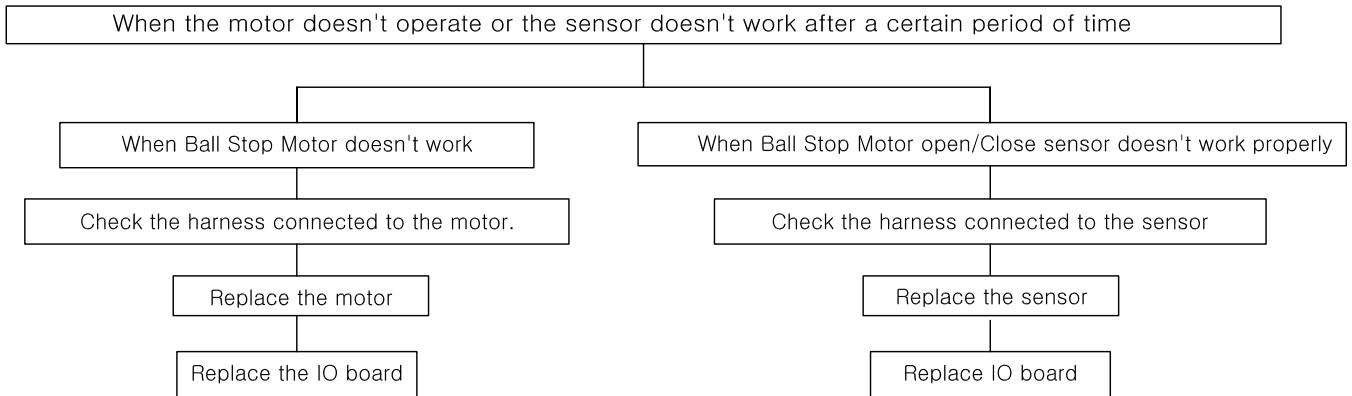

Ball Stop Motor
KGY SERIES MOTOR K6DG15N1
(12V-15W, 15rpm, 1/200)

Ball Stop Motor UP Switch
(MICRO SWITCH GSM-V1653A2)

Ball Stop Motor DOWN Switch
(MICRO SWITCH GSM-V1653A2)

Reference : BALL DROP STOP OPERATION Ass'y

11. ASSEMBLING PIXEL CHASE

11-1.AC POWER SWITCH Ass'y

APIX0ASM001

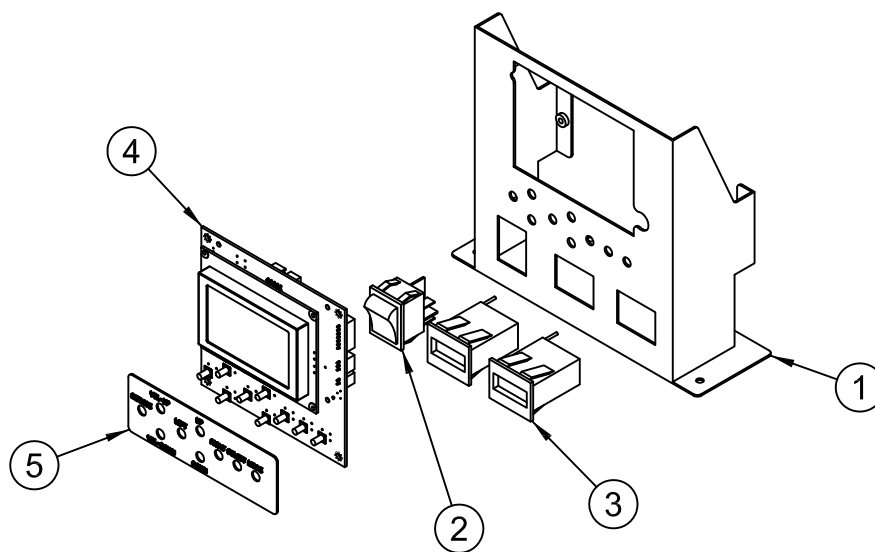

NO.	Code Number	QUANTITY	PART NAME	SPEC.
1	MPIX0MET013	1	AC POWER SWITCH BRACKET	SPCC-1.2t
2	MELE0SWI004	1	ROCKER SWITCH	T-125 4P
3	MZZZ0COU002	2	COUNTER	AMMC-712(OA127CL)
4	AMAR0BOA016	1	SETUP LCD BOARD Ass'y	KMLCD-1606-116A SETUP+MELE0LCB001 LCD
5	MMAROSHE001	1	SETUP PCB SHEET	SHEET

11-2. POWER SMPS Ass'y

APIX0ASM034

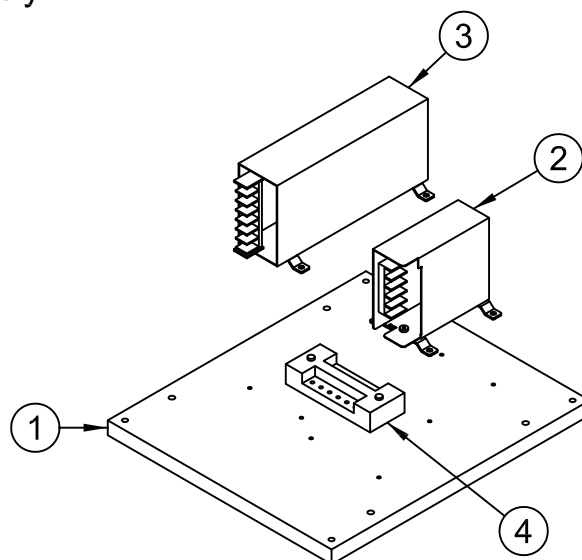

NO.	Code Number	QUANTITY	PART NAME	SPEC.
1	MPIX0WOO018	1	SMPS PLATE	PW-15.0t
2	MELE0SMP035	1	POWER-SMPS(ORIENT) JSF75-05	110~240V/5V12A
3	MELE0SMP031	1	POWER-SMPS(ORIENT) JSF150-12	110~240V/12V-12.5A
4	MELE0TEB001	1	TERMINAL BLOCK (6P)	6P UL

11-3. NOISE FILTER Ass'y

APIX0ASM030

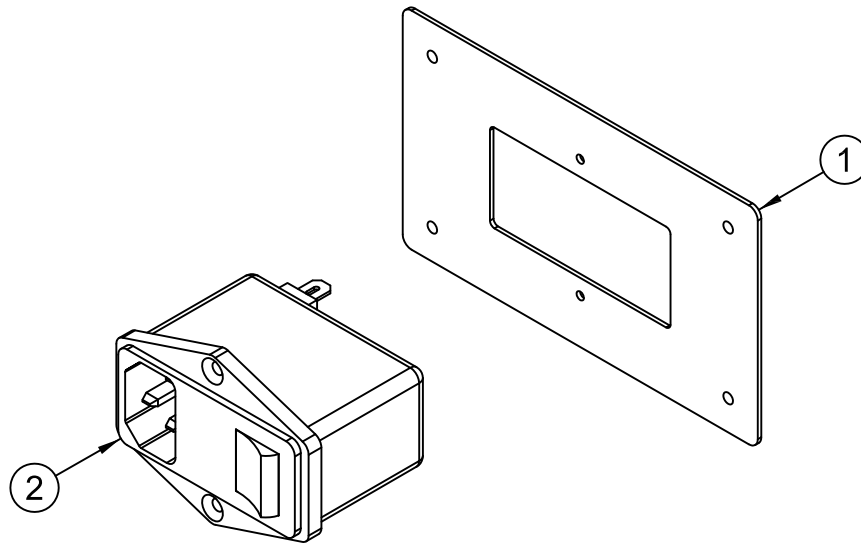

NO.	Code Number	QUANTITY	PART NAME	SPEC.
1	MPIX0MET018	1	AC INPUT BRACKET	SPCC-1.2t
2	MELE0NOI002	1	NOISE FILTER	IP-0642-H2

11-4. PIXEL MAIN BOARD Ass'y

APIX0ASM032

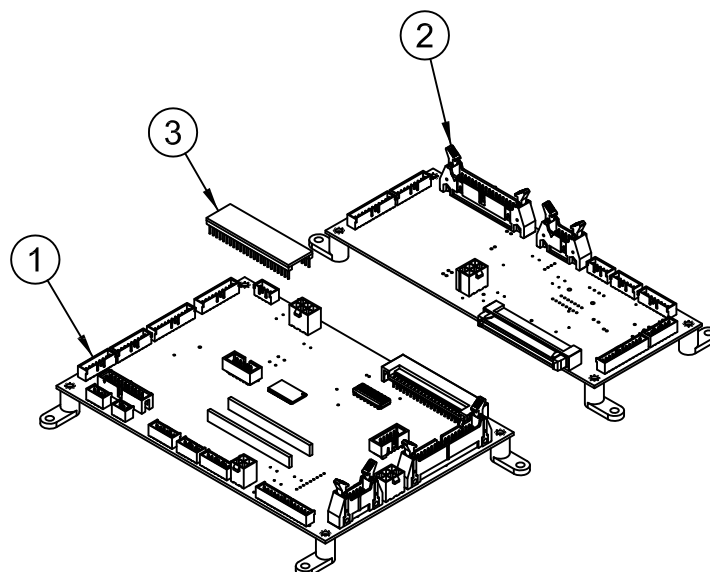

NO.	Code Number	QUANTITY	PART NAME	SPEC.
1	APIX0BOA011	1	PIXEL CHASE MAIN BOARD	KMMA-1606-104C
2	APIX0BOA013	1	PIXEL CHASE IO BOARD	KMIO-1803-170A
3	APIX0BOA012	1	PIXEL SOUND-IC64 BOARD	KMMM100808A

11-5. CASH BOX Ass'y

APIX0ASM014

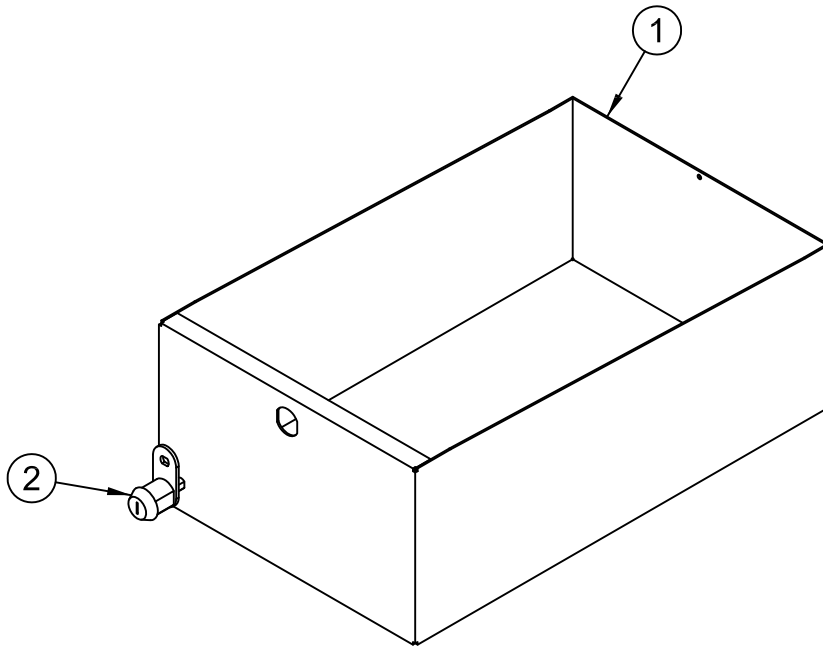

NO.	Code Number	QUANTITY	PART NAME	SPEC.
1	MPIX0MET012	1	CASH BOX	SPCC-1.2t
2	MZZZ0KEY013	1	key ass'y(6001)	6001

11-6. CASH BOX BODY Ass'y

APIX0ASM015

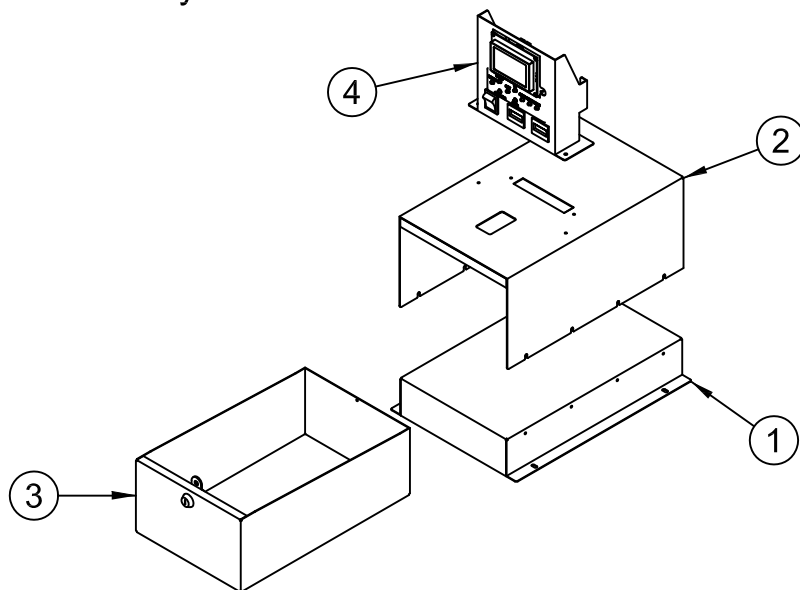

NO.	Code Number	QUANTITY	PART NAME	SPEC.
1	MPIX0MET010	1	CASH BOX BODY BOTTOM	SPCC-1.2t
2	MPIX0MET011	1	CASH BOX BODY COVER WELD Ass'y	WELD Ass'y (용접물)
3	APIX0ASM014	1	CASH BOX Ass'y	11-5. (24page)
4	APIX0ASM001	1	AC POWER SWITCH Ass'y	11-1. (22page)

11-7. FRONT TITLE ACRYL Ass'y

APIX0ASM023

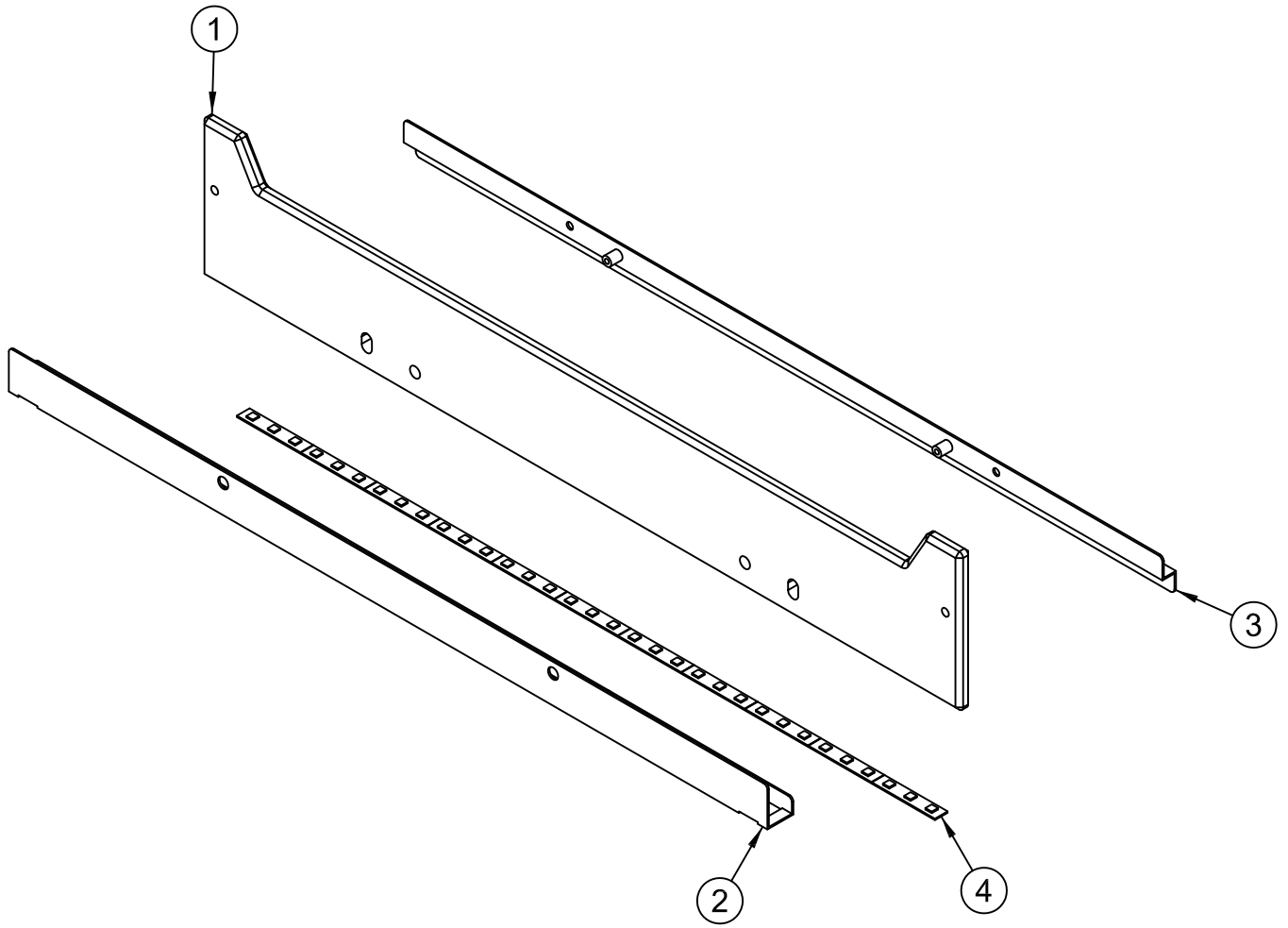

NO.	Code Number	QUANTITY	PART NAME	SPEC.
1	MPIX0A&S002	1	FRONT TITLE ACRYL	CLEAR ACRYL - 10.0t (투명아크릴)
2	MPIX0MET016	1	TITLE ACRYL FIX BRKT	SPCC-1.2t
3	MPIX0MET017	1	TITLE LED BACK SUPPORT BRKT	SPCC-1.2t
4	APIX0FLM003	1	FRONT TITLE FLEXIBLE	550-1/3-50L-32LED (R.G.B)

11-8. SCORE BOX BOTTOM LED Ass'y

APIX0ASM038

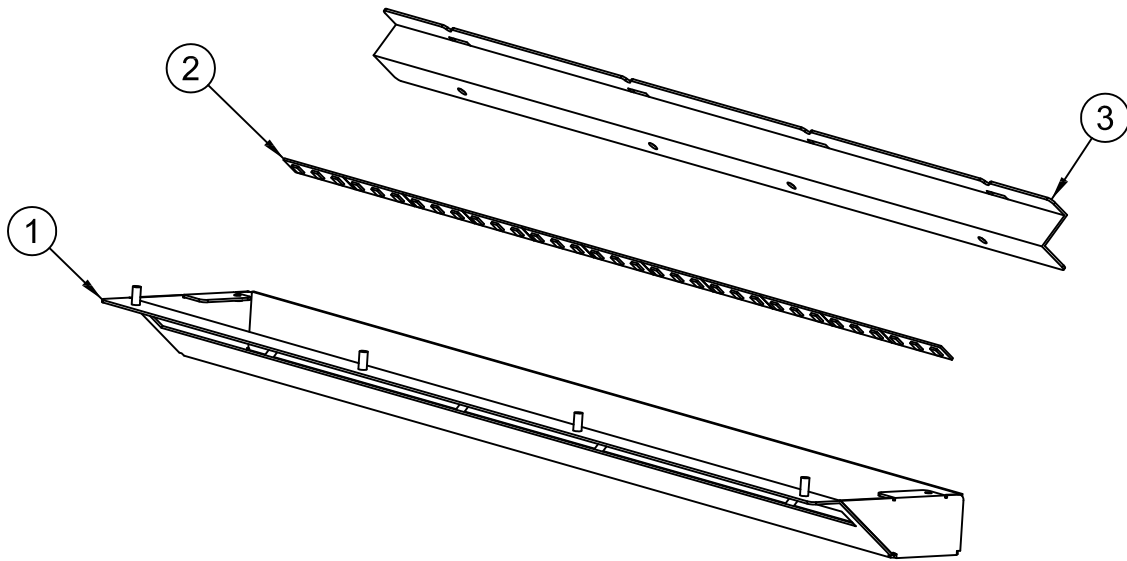

NO.	Code Number	QUANTITY	PART NAME	SPEC.
1	MPIX0MET020	1	SCORE BOX BOTTOM LED BASE BRKT	SPCC-1.2t
2	APIX0FLM001	1	BALL FOCUS FLEXIBLE	550-1/3-50L-32LED (PINK)
3	MPIX0MET021	1	SCORE BOX FLEXIBLE LED FIX BRKT	SPCC-1.2t

11-9. SCORE PART FLEXIBLE Ass'y (RED)

APIX0ASM051

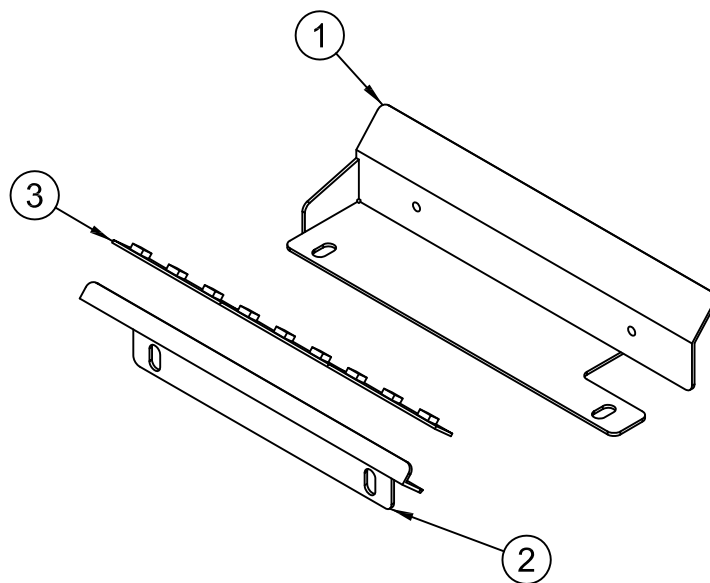

NO.	Code Number	QUANTITY	PART NAME	SPEC.
1	MPIX0MET037	1	SCORE PART FLEXIBLE BACK BASE BRKT	SPCC-1.2t
2	MPIX0MET038	1	SCORE PART FLEXIBLE BRKT	SPCC-1.2t
3	APIX0FLM004	1	SCORE PART LIGHT FLEXIBLE	150-1/3-50L-9LED (RED)

11-10. SCORE PART FLEXIBLE Ass'y (BLUE)

APIX0ASM049

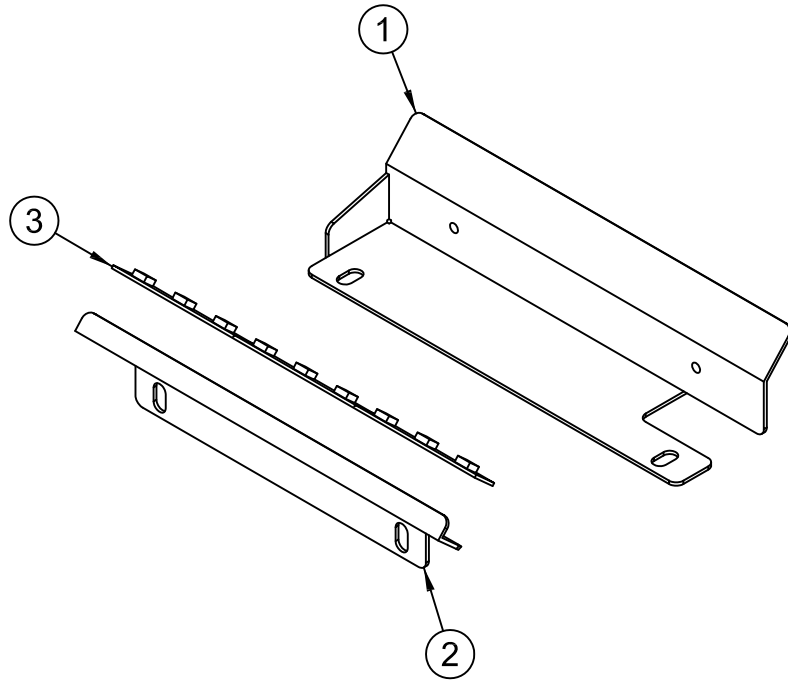

NO.	Code Number	QUANTITY	PART NAME	SPEC.
1	MPIX0MET037	1	SCORE PART FLEXIBLE BACK BASE BRKT	SPCC-1.2t
2	MPIX0MET038	1	SCORE PART FLEXIBLE BRKT	SPCC-1.2t
3	APIX0FLM005	1	SCORE PART LIGHT FLEXIBLE	150-1/3-50L-9LED (BLUE)

11-11. SCORE PART FLEXIBLE Ass'y (GREEN)

APIX0ASM050

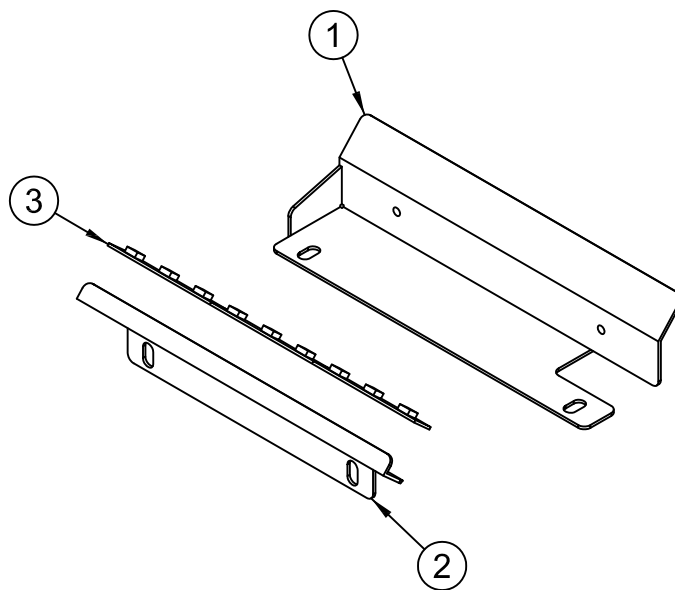

NO.	Code Number	QUANTITY	PART NAME	SPEC.
1	MPIX0MET037	1	SCORE PART FLEXIBLE BACK BASE BRKT	SPCC-1.2t
2	MPIX0MET038	1	SCORE PART FLEXIBLE BRKT	SPCC-1.2t
3	APIX0FLM006	1	SCORE PART LIGHT FLEXIBLE	150-1/3-50L-9LED (GREEN)

11-12. SCORE PART LIGHT Ass'y

APIX0ASM041

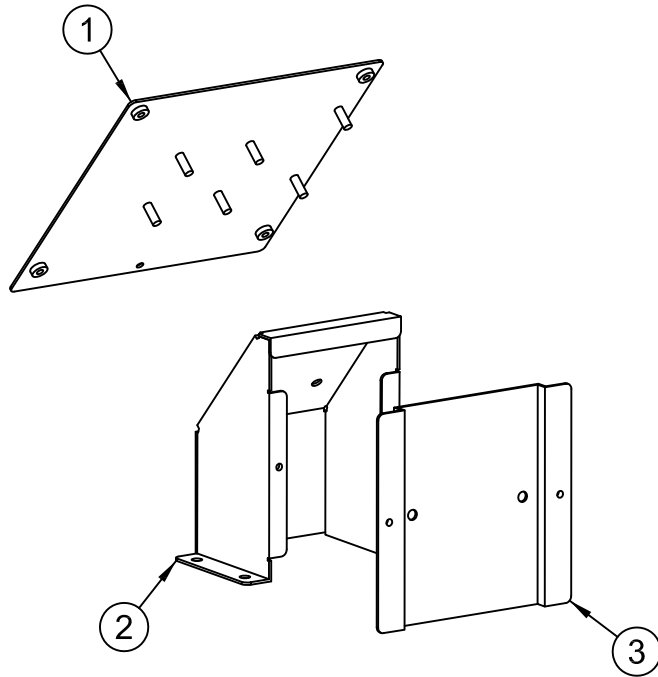

NO.	Code Number	QUANTITY	PART NAME	SPEC.
1	MPIX0MET027	1	SCORE PART LIGHT ACRYL BACK BRKT	SPCC-1.2t
2	MPIX0MET030	1	SCORE PART LIGHT ACRYL FIX BRKT	SPCC-1.2t
3	MPIX0MET031	1	SCORE PART LIGHT FIX BACK COVER BRKT	SPCC-1.2t

11-13. SCORE PART LIGHT Ass'y_mir

APIX0ASM042

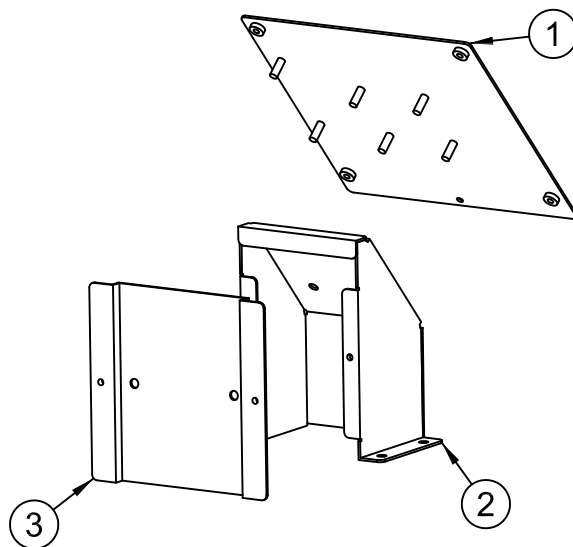

NO.	Code Number	QUANTITY	PART NAME	SPEC.
1	MPIX0MET028	1	SCORE PART LIGHT ACRYL BACK BRKT_mir	SPCC-1.2t
2	MPIX0MET030	1	SCORE PART LIGHT ACRYL FIX BRKT	SPCC-1.2t
3	MPIX0MET031	1	SCORE PART LIGHT FIX BACK COVER BRKT	SPCC-1.2t

11-14. PIR SENSOR BASE Ass'y

APIX0ASM024

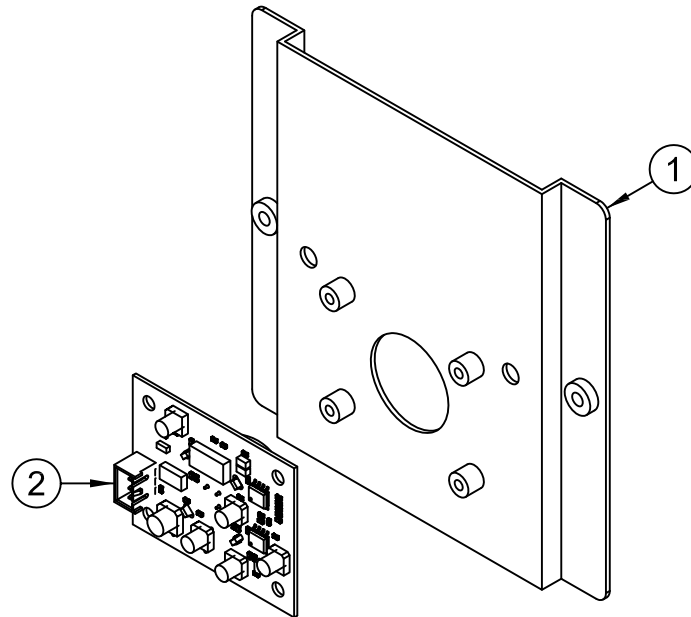

NO.	Code Number	QUANTITY	PART NAME	SPEC.
1	MPIX0MET032	1	SCORE PART LIGHT FIX BACK COVER CENTER	SPCC-1.2t
2	APIX0BOA015	1	PIR SENSOR BOARD	KMSEN-1805-171A

11-15. SCORE PART LIGHT CENTER Ass'y

APIX0ASM043

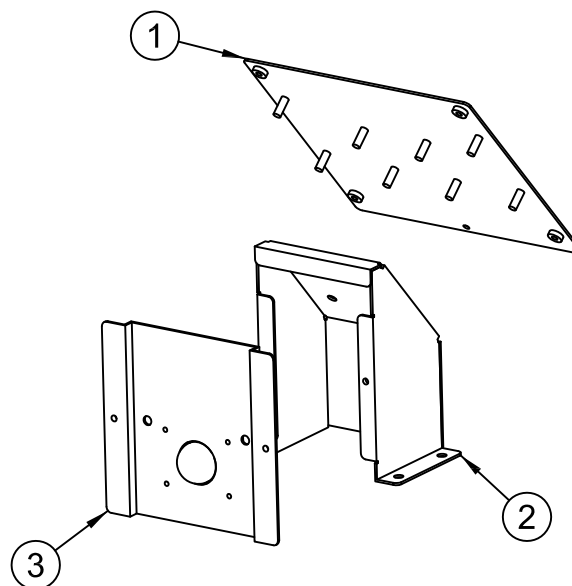

NO.	Code Number	QUANTITY	PART NAME	SPEC.
1	MPIX0MET029	1	SCORE PART LIGHT ACRYL BACK CENTER BRKT	SPCC-1.2t
2	MPIX0MET030	1	SCORE PART LIGHT ACRYL FIX BRKT	SPCC-1.2t
3	APIX0ASM024	1	PIR SENSOR BASE Ass'y	11-14. (29page)

11-16. SPEAKER Ass'y

APIX0ASM044

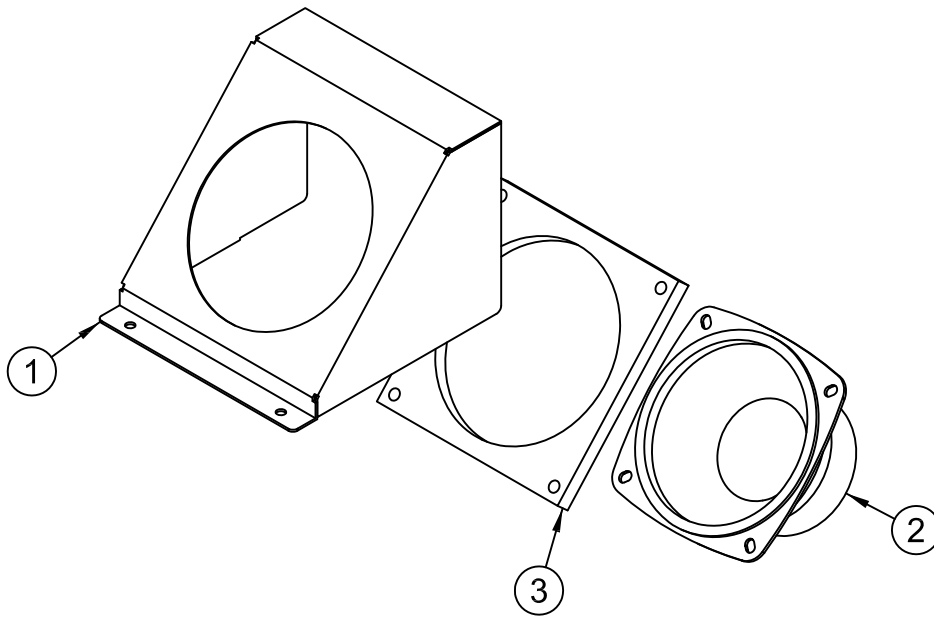

NO.	Code Number	QUANTITY	PART NAME	SPEC.
1	MPIX0MET035	1	SPEAKER BASE BRKT	SPCC-1.2t
2	MZZZ0SPE004	1	speaker[MID4.5]	MID 4.5 8Ω80W
3	MPIX0WOO017	1	SPEAKER WOOD PANEL	PW-9T

11-17. SPEAKER Ass'y_mir

APIX0ASM045

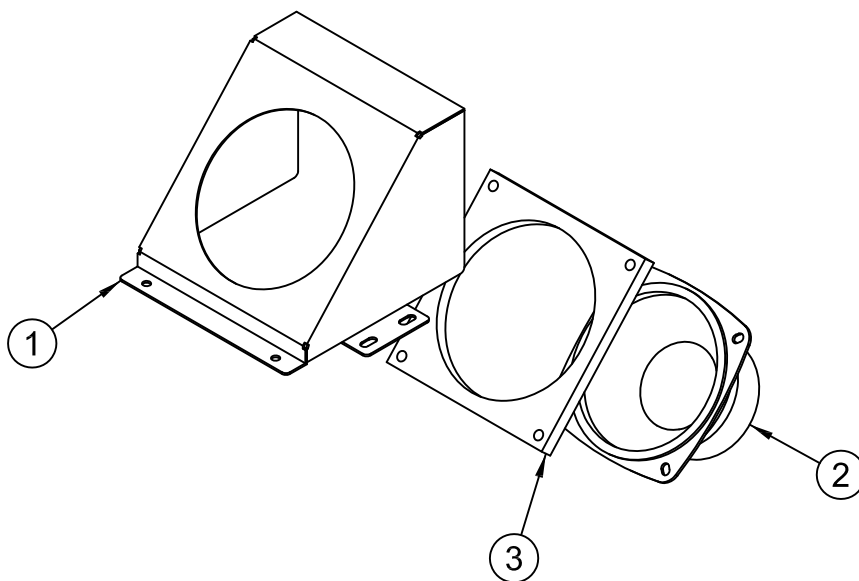

NO.	Code Number	QUANTITY	PART NAME	SPEC.
1	MPIX0MET036	1	SPEAKER BASE BRKT_mir	SPCC-1.2t
2	MZZZ0SPE004	1	speaker[MID4.5]	MID 4.5 8Ω80W
3	MPIX0WOO017	1	SPEAKER WOOD PANEL	PW-9T

11-18. BALL DROP STOP OPERATION Ass'y

APIX0ASM002

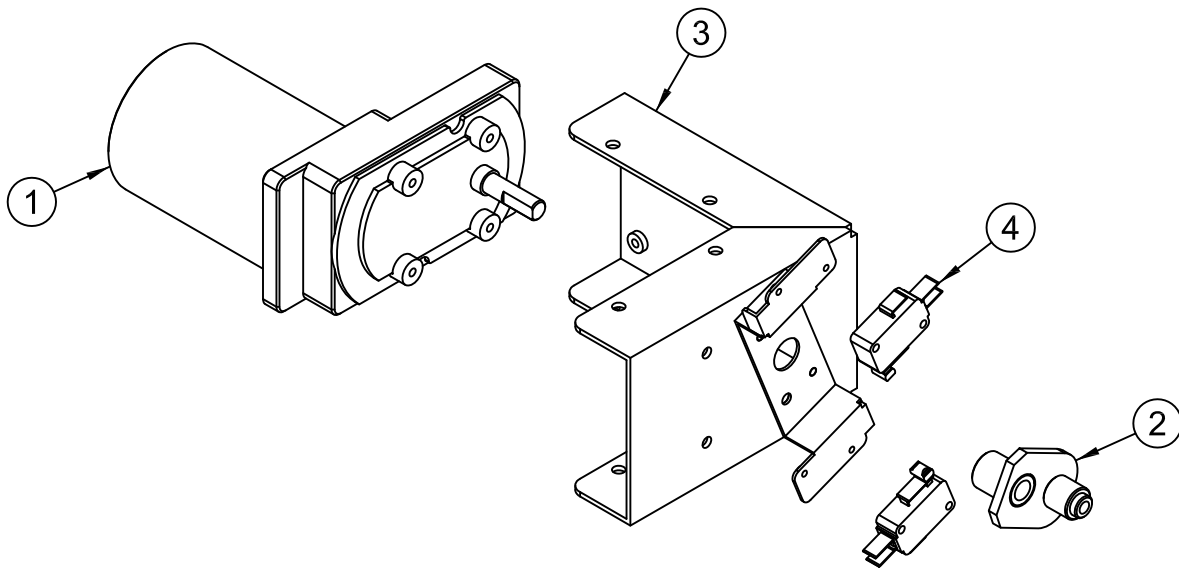

NO.	Code Number	QUANTITY	PART NAME	SPEC.
1	MZZZ0MOT050	1	KGY SERIES MOTOR (200)	K6DG15N1 (1/200, 15RPM)
2	MPIX0PRO001	1	BALL STOPPER OPERATION LINK WELD Ass'y	WELD Ass'y (용접물)
3	MPIX0MET023	1	OPERATION MOTOR SUPPORT WELD Ass'y	WELD Ass'y (용접품)
4	MZZZ0000278	2	MICRO SWITCH (GSM-V1653V2)	GSM-V1653A2 NO TAEP

11-19. BALL STOPPER DOOR Ass'y

APIX0ASM005

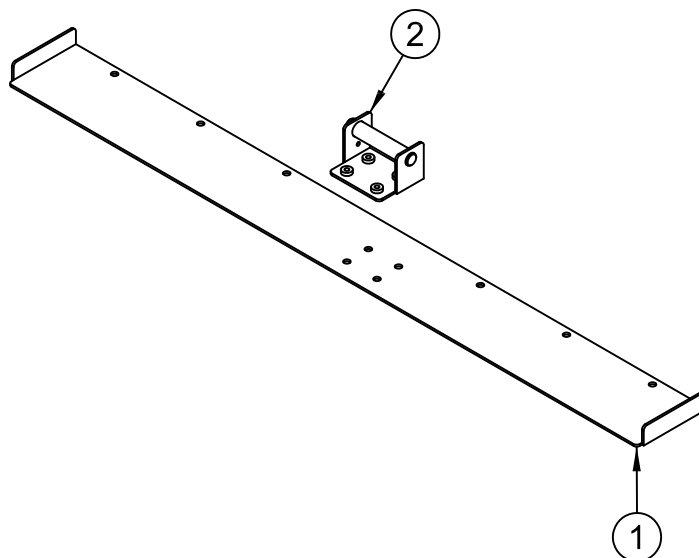

NO.	Code Number	QUANTITY	PART NAME	SPEC.
1	MPIX0MET024	1	BALL STOPPER BRKT	SPCC-1.6t
2	MPIX0MET025	1	BALL STOPPER LINK BRKT B WELD Ass'y	WELD Ass'y (용접물)

11-20.SCORE BOX COVER Ass'y

APIX0ASM039

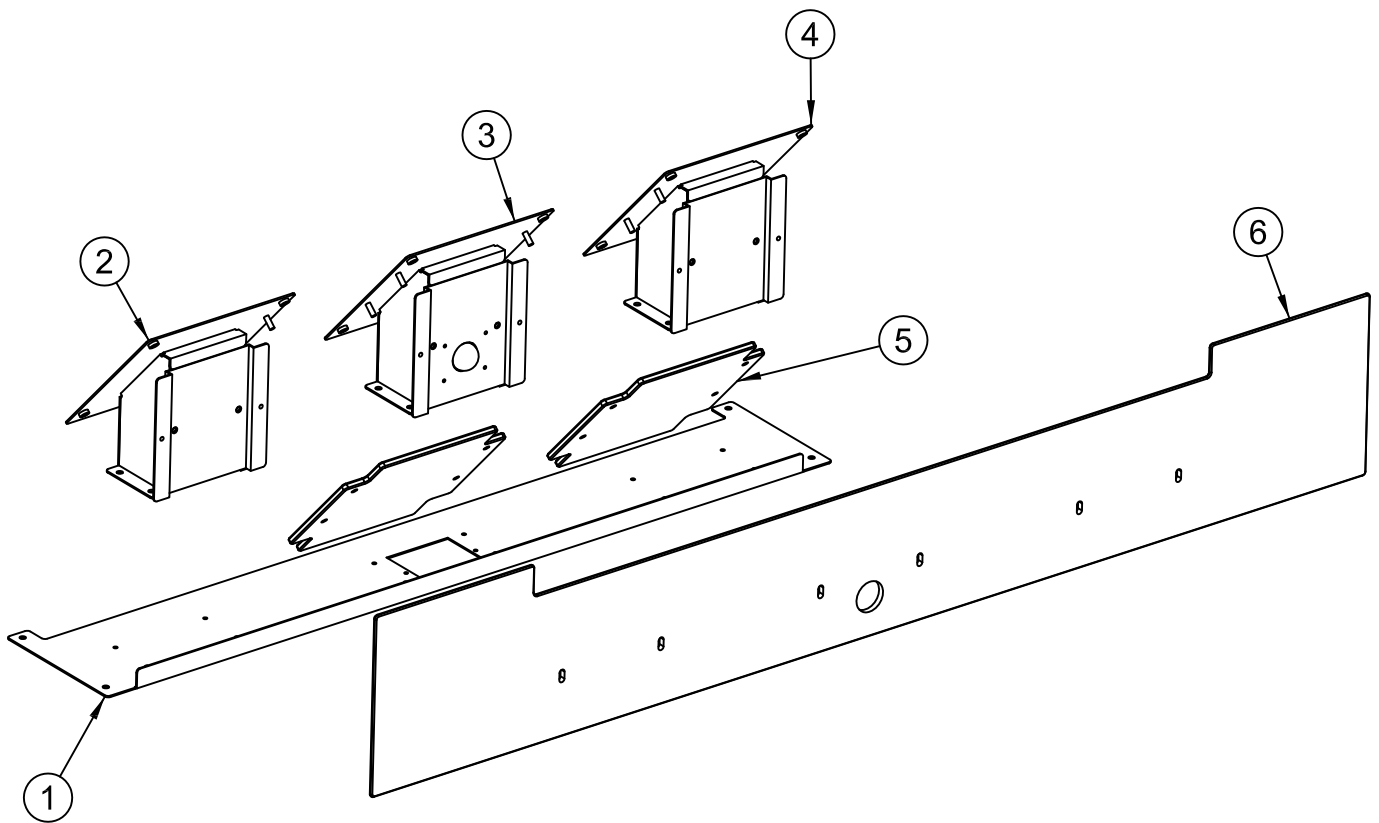

NO.	Code Number	QUANTITY	PART NAME	SPEC.
1	MPIX0MET026	1	SCORE BOX OPERATION COVER BRKT	SPCC-1.2t
2	APIX0ASM041	1	SCORE PART LIGHT Ass'y	11-12. (28page)
3	APIX0ASM043	1	SCORE PART LIGHT CENTER Ass'y	11-15. (29page)
4	APIX0ASM042	1	SCORE PART LIGHT Ass'y_mir	11-13. (28page)
5	MPIX0ACR003	2	SCORE PART INTER ACRYL	CLEAR ACRYL - 5.0t (투명아크릴)
6	MPIX0ACR004	1	BALL OPERATION UPPER STOP PC ACRYL	CLEAR PC-5.0t (투명)

11-21.MIDDLE BALL PROTECT Ass'y

APIX0ASM025

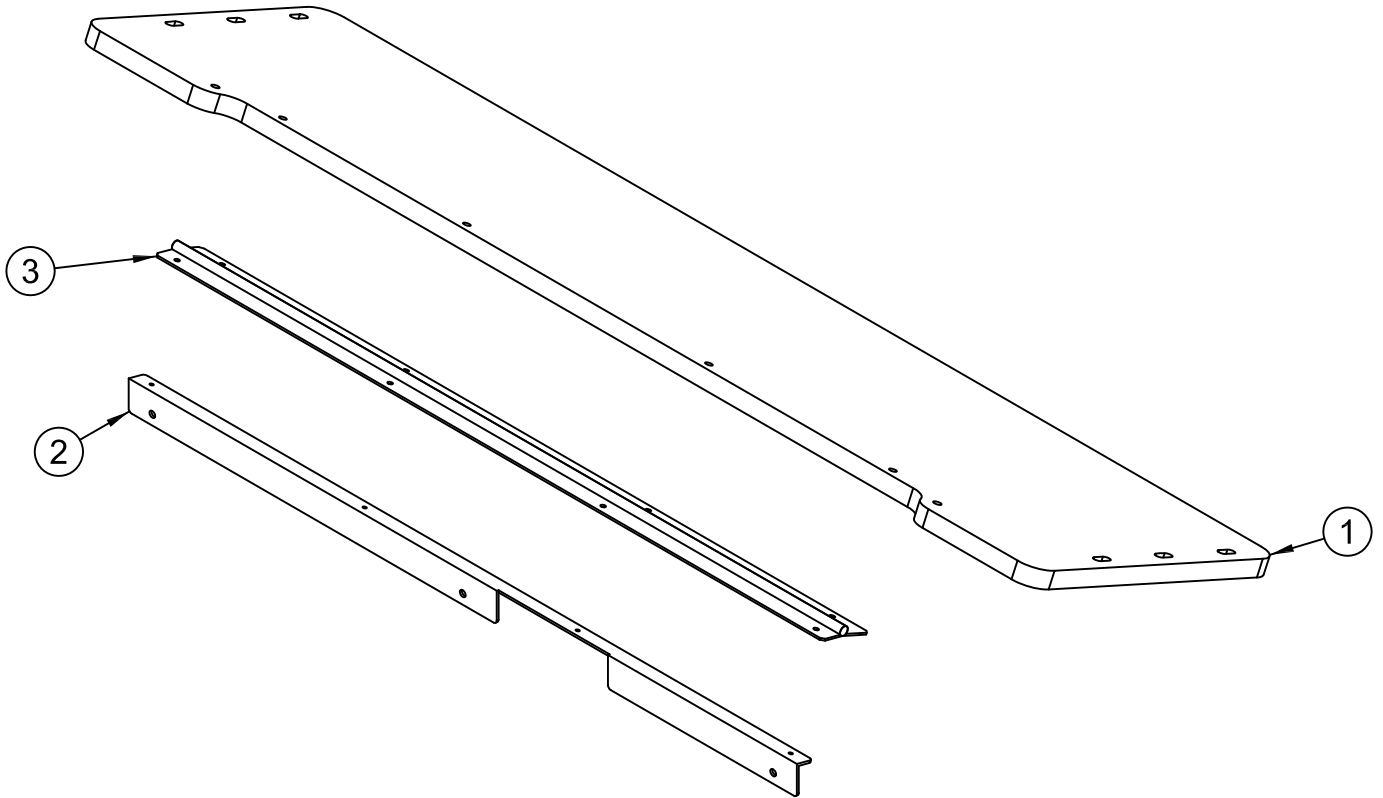

NO.	Code Number	QUANTITY	PART NAME	SPEC.
1	MPIX0WOO002	1	MIDDLE BALL HAND STOP PANEL	PW-15t
2	MPIX0MET033	1	BALL PROTECT PANEL FIX BRKT	SPCC-2t
3	MPIX0MET034	1	BALL PROTECT HINGE Ass'y	SPCC-1.6t

11-22. SCORE FND BOX Ass'y

APIX0ASM040

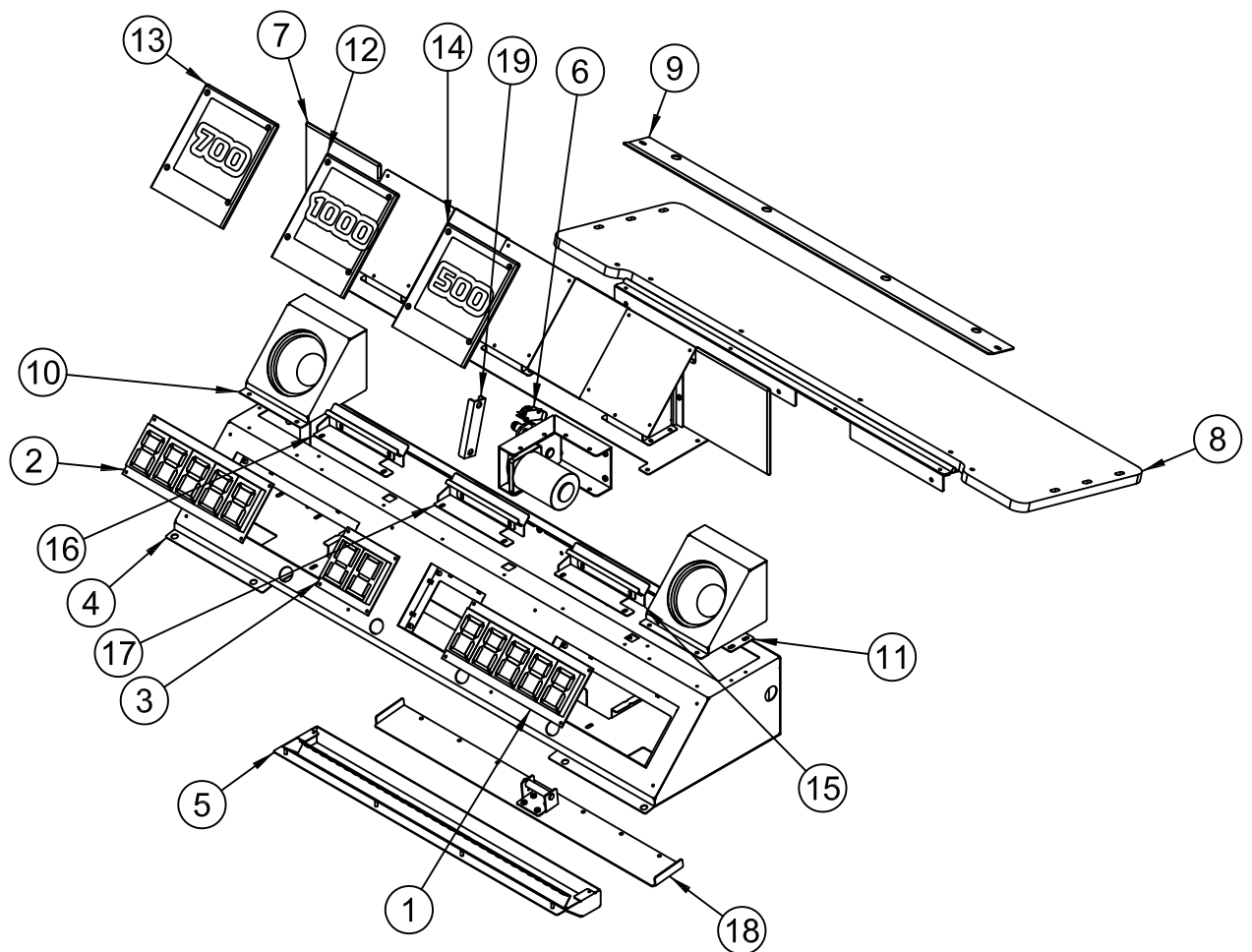

NO.	Code Number	QUANTITY	PART NAME	SPEC.
1	APIX0BOA003	1	HIGH SCORE FND 5P (RED)	KMFND-1707-142A
2	APIX0BOA002	1	HIGH SCORE FND 5P (BLUE)	KMFND-1707-142A
3	APIX0BOA001	1	TIME FND 2P	KMFND-1707-143A
4	MPIX0MET019	1	SCORE FND BOX WELD Ass'y	WELD Ass'y (용접물)
5	APIX0ASM038	1	SCORE BOX BOTTOM LED Ass'y	11-8. (26page)
6	APIX0ASM002	1	BALL DROP STOP OPERATION Ass'y	11-18. (31page)
7	APIX0ASM039	1	SCORE BOX COVER Ass'y	11-20. (32page)
8	APIX0ASM025	1	MIDDLE BALL PROTECT Ass'y	11-21. (33page)
9	MPIX0MET104	1	BALL PROTECT PANEL UPPER BRKT	SPCC-1.6t
10	APIX0ASM044	1	SPEAKER Ass'y	11-16. (30page)
11	APIX0ASM045	1	SPEAKER Ass'y_mir	11-17. (30page)
12	MPIX0ACR007	1	SCORE PART LIGHT ACRYL (1000)	CLEAR ACRYL-10.0t (투명아크릴)
13	MPIX0ACR006	1	SCORE PART LIGHT ACRYL (700)	CLEAR ACRYL-10.0t (투명아크릴)
14	MPIX0ACR005	1	SCORE PART LIGHT ACRYL (500)	CLEAR ACRYL-10.0t (투명아크릴)
15	APIX0ASM049	1	SCORE PART FLEXIBLE Ass'y (BLUE)	11-10. (27page)
16	APIX0ASM050	1	SCORE PART FLEXIBLE Ass'y (GREEN)	11-11. (27page)
17	APIX0ASM051	1	SCORE PART FLEXIBLE Ass'y (RED)	11-9. (26page)
18	APIX0ASM005	1	BALL STOPPER DOOR Ass'y	11-19. (31page)
19	MPIX0MET022	1	BALL STOPPER OPERATION LINK BLOCK BRKT	SPCC-2t

11-23.TICKET BOX Ass'y

APIX0ASM046

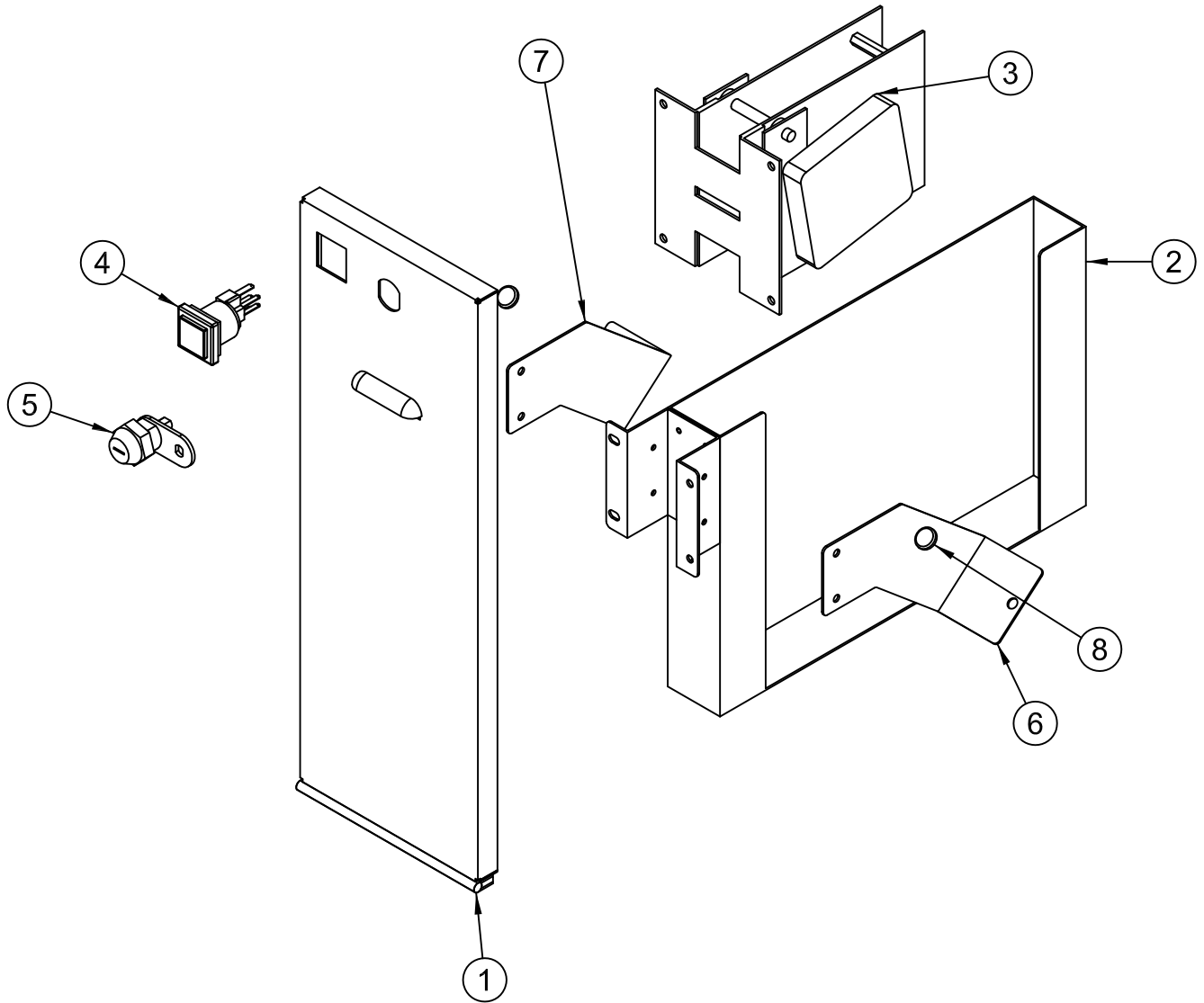

NO.	Code Number	QUANTITY	PART NAME	SPEC.
1	MPIX0MET002	1	TICKET DOOR WELD Ass'y	WELD Ass'y (용접물)
2	MPIX0MET003	1	TICKET BOX WELD Ass'y	WELD Ass'y (용접물)
3	MZZZ0TID003	1	TICKET DISPENSER	CLECO
4	MHA20000007	1	BUTTON ASS'Y(소형)	AM1PB-26SH-R12D
5	MZZZ0KEY032	1	KEY ASS'Y	7001
6	MPIX0MET004	1	TICKET DOOR STOP BAR	SPCC-1.2t
7	MPIX0MET005	1	TICKET DOOR STOP BAR_mir	SPCC-1.2t
8	MZZZ0RUB003	2	SHOCK ABSORBER	6Φ

11-24.FRONT MIDDLE DOOR ASSY

APIX0ASM021

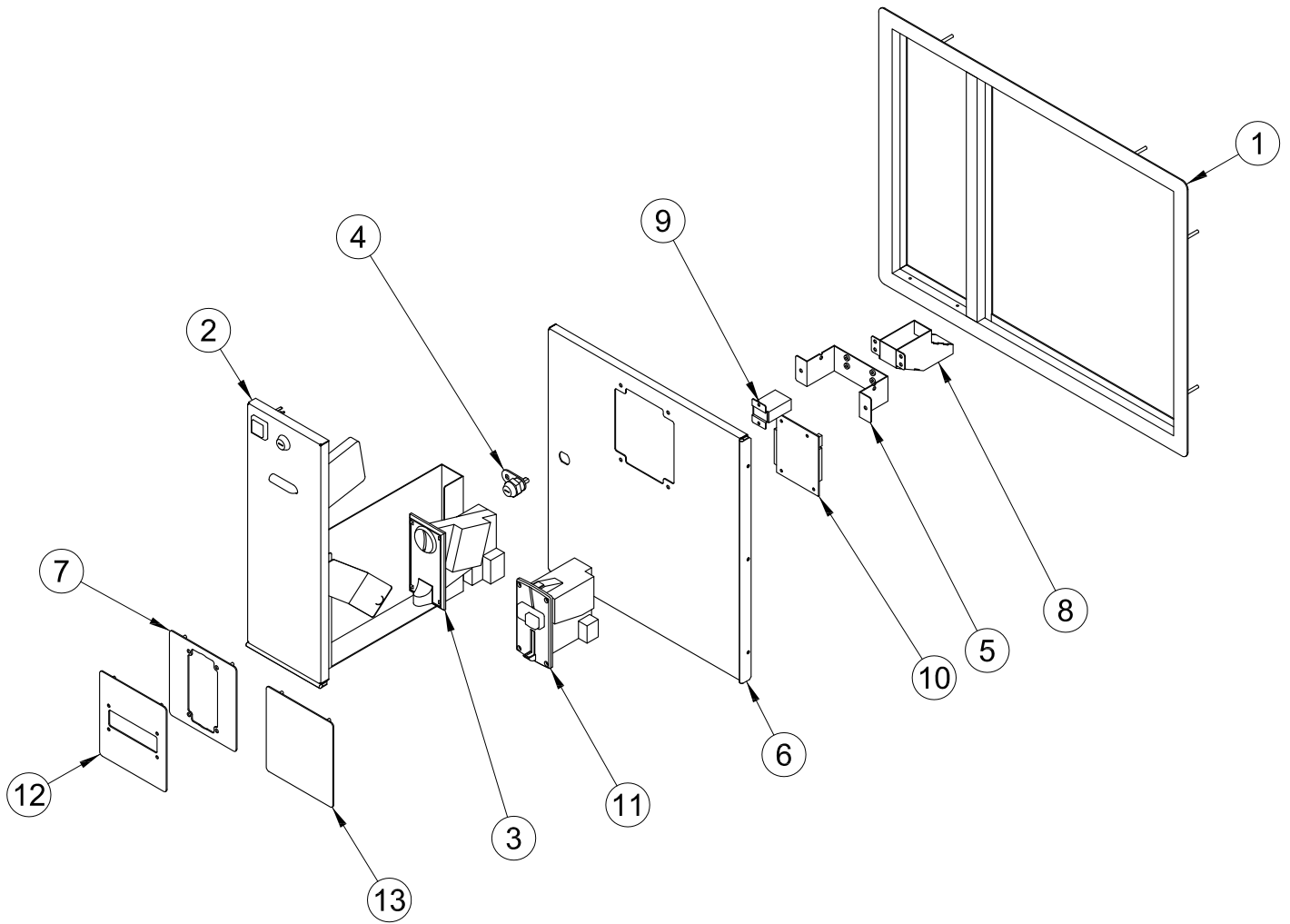

NO.	Code Number	QUANTITY	PART NAME	SPEC.
1	MPIX0MET001	1	FRONT MIDDLE DOOR WELD Ass'y	WELD Ass'y (용접물)
2	APIX0ASM046	1	TICKET BOX Ass'y	11-23. (35page)
3	MZZZ0COS025	1	COIN SELECTOR(TONGLI)	TW-130Q
4	MZZZ0KEY032	1	KEY ASS'Y	7001
5	MPIX0MET006	1	COIN ACCEPT FIX BRKT	SPCC-1.2t
6	MPIX0MET007	1	FRONT OPEN DOOR WELD ASSY	WELD Ass'y (용접물)
7	MPIX0MET008	1	COIN SELECTOR FIXED BKT	SPCC-1.6t
8	MPIX0MET009	1	COIN GUIDE ANGLE WELD Ass'y	WELD Ass'y (용접물)
9	MZZZ0000488	1	COUNTER UK (SR3)	UK OPTION
10	MZZZ0000489	1	EXCEL CREDIT(SR3) PCB	UK OPTION
11	MZZZ0000486	1	SR3 FRONT (UK)	UK OPTION
12	MPIX0MET119	1	CARD SWIFE FIXED BKT	OPTION
13	MPIX0MET120	1	DUBAI COIN DOOR BRKT	DUBAI OPTION

11-25.FRONT SCORE TICKET Ass'y

APIX0ASM022

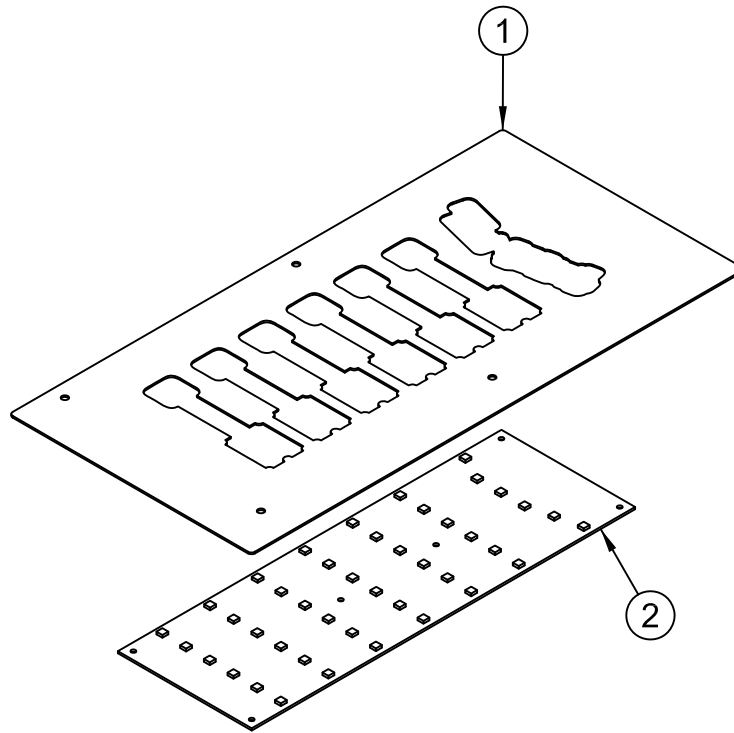

NO.	Code Number	QUANTITY	PART NAME	SPEC.
1	MPIX0MET015	1	FRONT SCORE TICKET FND BRKT	SPCC-1.2t
2	APIX0BOA007	1	SCORE TICKET BOARD	KMFND-1711-154B

11-26.CREDIT FND Ass'y

APIX0ASM018

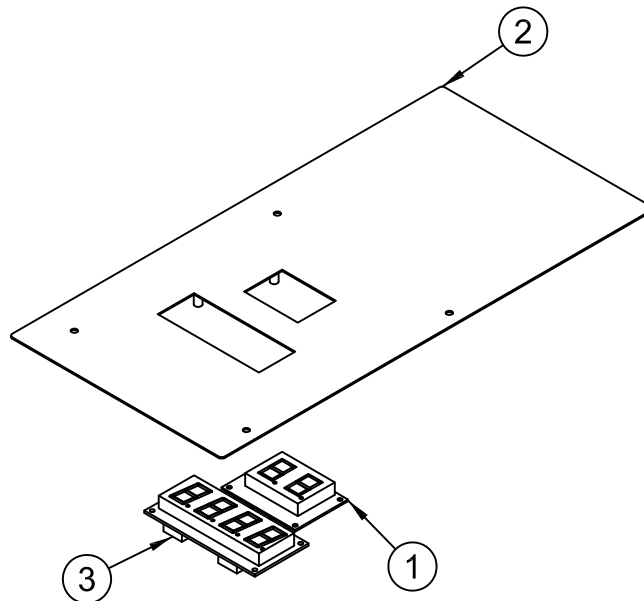

NO.	Code Number	QUANTITY	PART NAME	SPEC.
1	ACOU0PCB010	1	CREDIT FND	KMCF1017-2A
2	MPIX0MET014	1	FRONT CREDIT FND BRKT	SPCC-1.2t
3	ATOD0BOA002	1	TICKET OWED FND4	KMFND-055A

11-27. MIDDLE WOOD PANEL Ass'y

APIX0ASM029

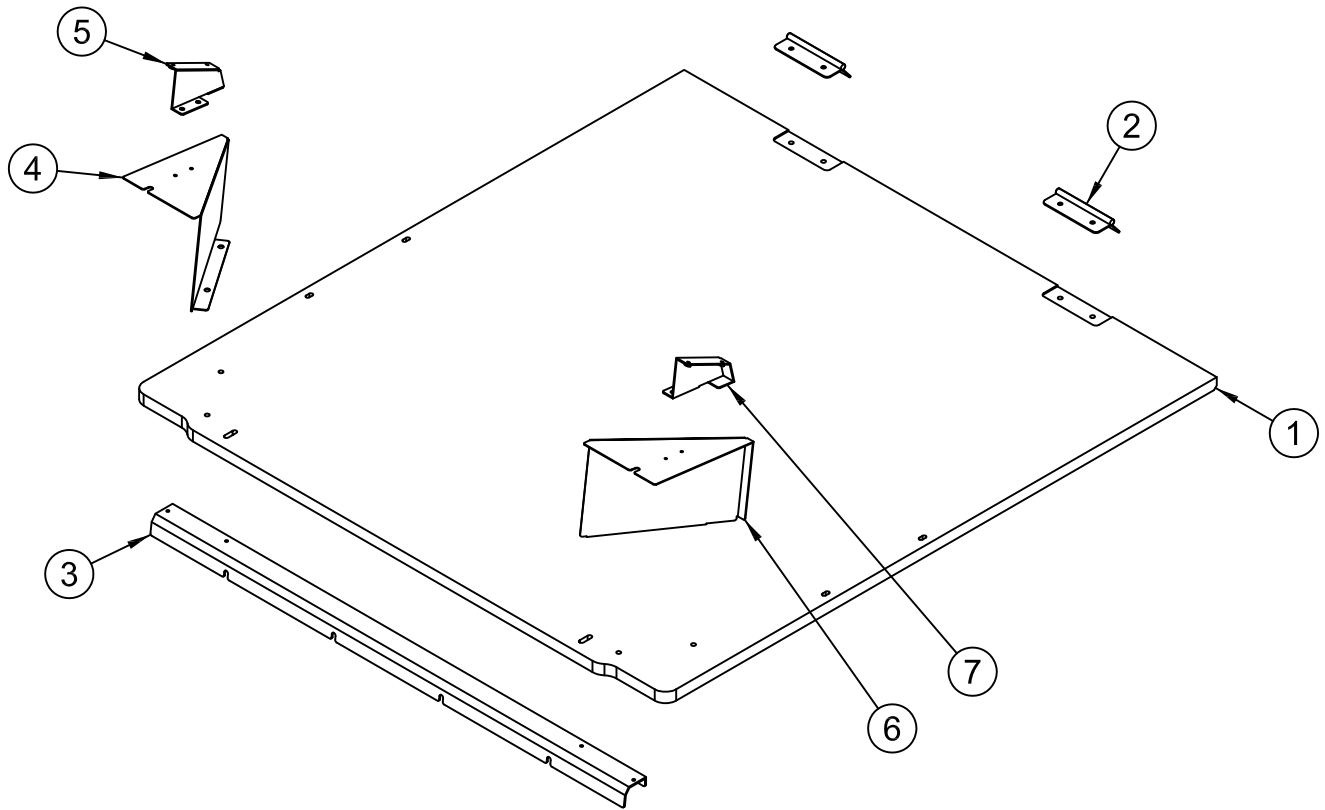

NO.	Code Number	QUANTITY	PART NAME	SPEC.
1	MPIX0WOO001	1	MIDDLE WOOD PANEL	PW-18t
2	MPIX0MET046	2	MIDDLE PANEL HINGE Ass'y	SPCC-1.6t
3	MPIX0MET051	1	MIDDLE PANEL FIX BRKT	SPCC-2t
4	MPIX0MET047	1	BALL SLOPE BOTTOM BRKT	SPCC-1.2t
5	MPIX0MET050	1	BALL SLOPE UP BRKT_mir	SPCC-1.6t
6	MPIX0MET048	1	BALL SLOPE BOTTOM BRKT_mir	SPCC-1.2t
7	MPIX0MET049	1	BALL SLOPE UP BRKT	SPCC-1.6t

11-28. MIDDLE SIDE ACRYL FRAME Ass'y

APIX0ASM026

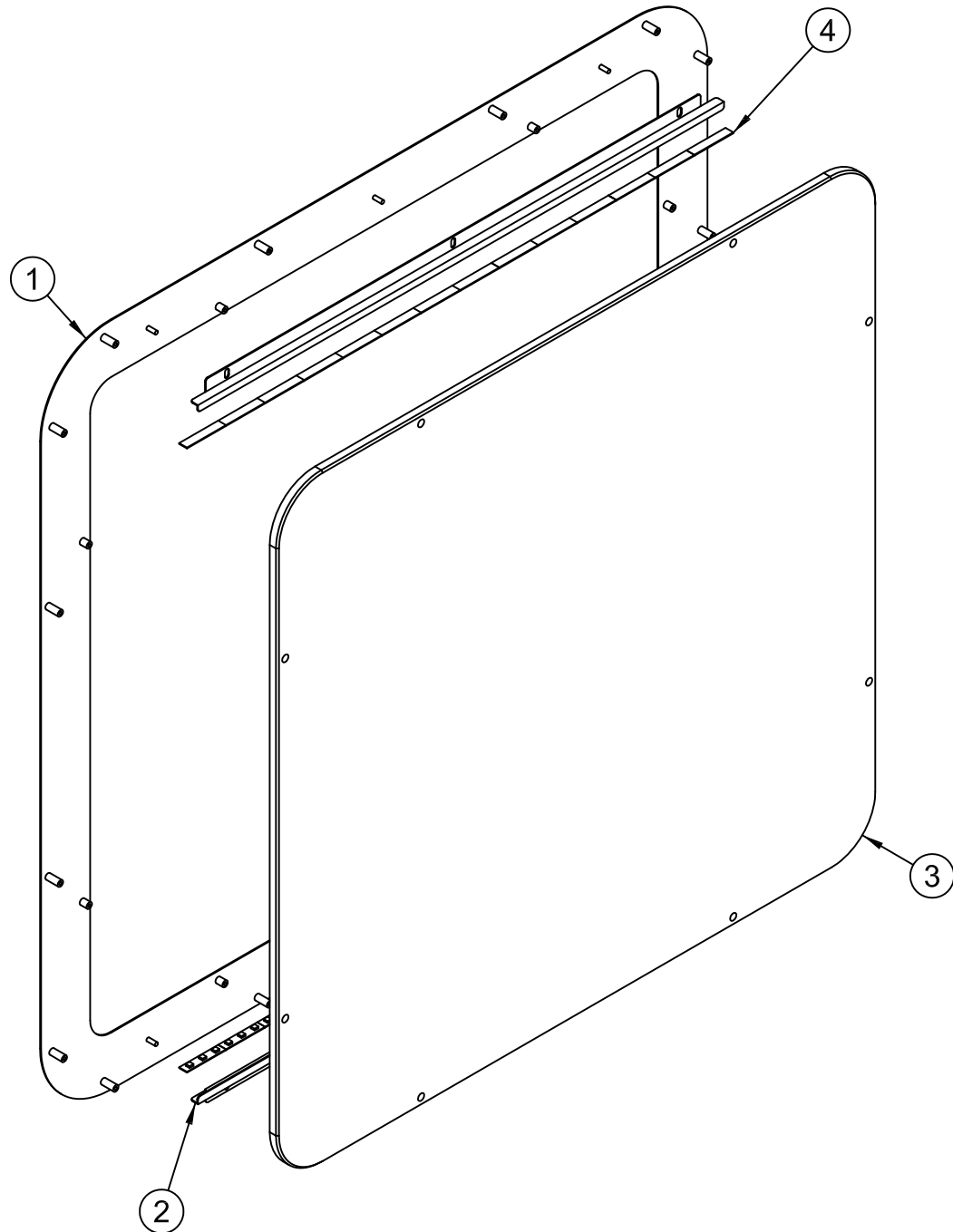

NO.	Code Number	QUANTITY	PART NAME	SPEC.
1	MPIX0MET081	1	MIDDLE SIDE ACRYL FRAME BRKT	SPCC-1.2t
2	MPIX0MET082	2	MIDDLE SIDE ACRYL FLEXIBLE FIX BRKT	SPCC-1.2t
3	MPIX0A&S005	1	MIDDLE SIDE ACRYL	CLEAR ACRYL - 10.0t (투명아크릴)
4	APIX0FLM002	2	MIDDLE SIDE ACRYL FLEXIBLE	700-1/3-50L-42LED (R.G.B)

11-29. MIDDLE SIDE PANEL Ass'y

APIX0ASM027

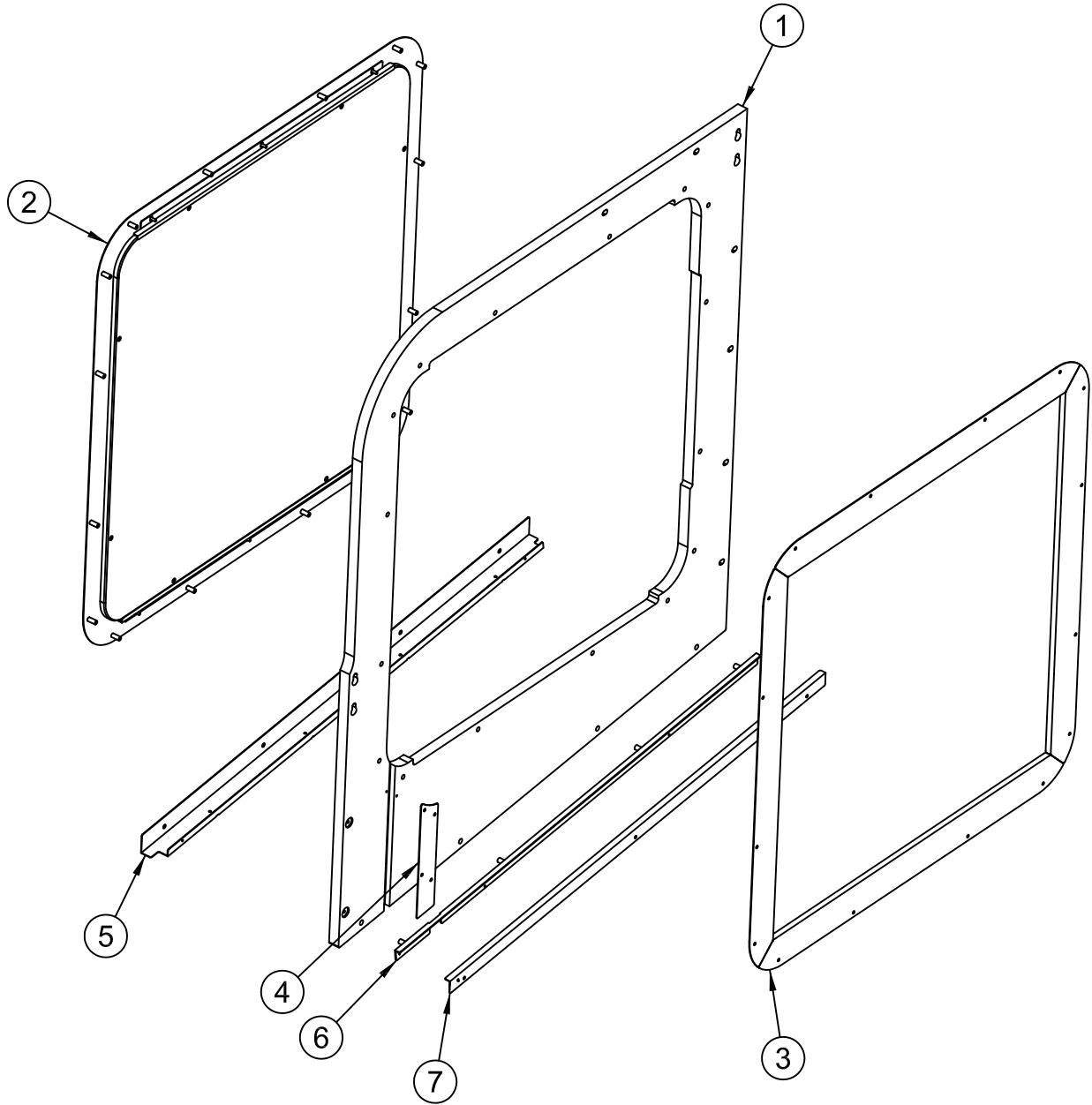

NO.	Code Number	QUANTITY	PART NAME	SPEC.
1	MPIX0WOO015	1	MIDDLE SIDE BASE PANEL	MDF-20t
2	APIX0ASM026	1	MIDDLE SIDE ACRYL FRAME Ass'y	11-28. (39page)
3	MPIX0MET083	4	MIDDLE SIDE FRAME FIX BRKT A	SPCC-1.2t
4	MPIX0MET084	1	MIDDLE SIDE INNER HARNESS COVER BRKT	SPCC-1.2t
5	MPIX0MET085	1	MIDDLE SIDE PANEL OUT COVER BRKT	SPCC-1.2t
6	MPIX0MET087	1	MIDDLE SIDE PANEL INNER FIX BRKT	SPCC-2.0t
7	MPIX0MET089	1	MIDDLE SIDE HARNESS COVER BRKT	SPCC-1.2t

11-30. MIDDLE SIDE PANEL Ass'y_mir

APIX0ASM028

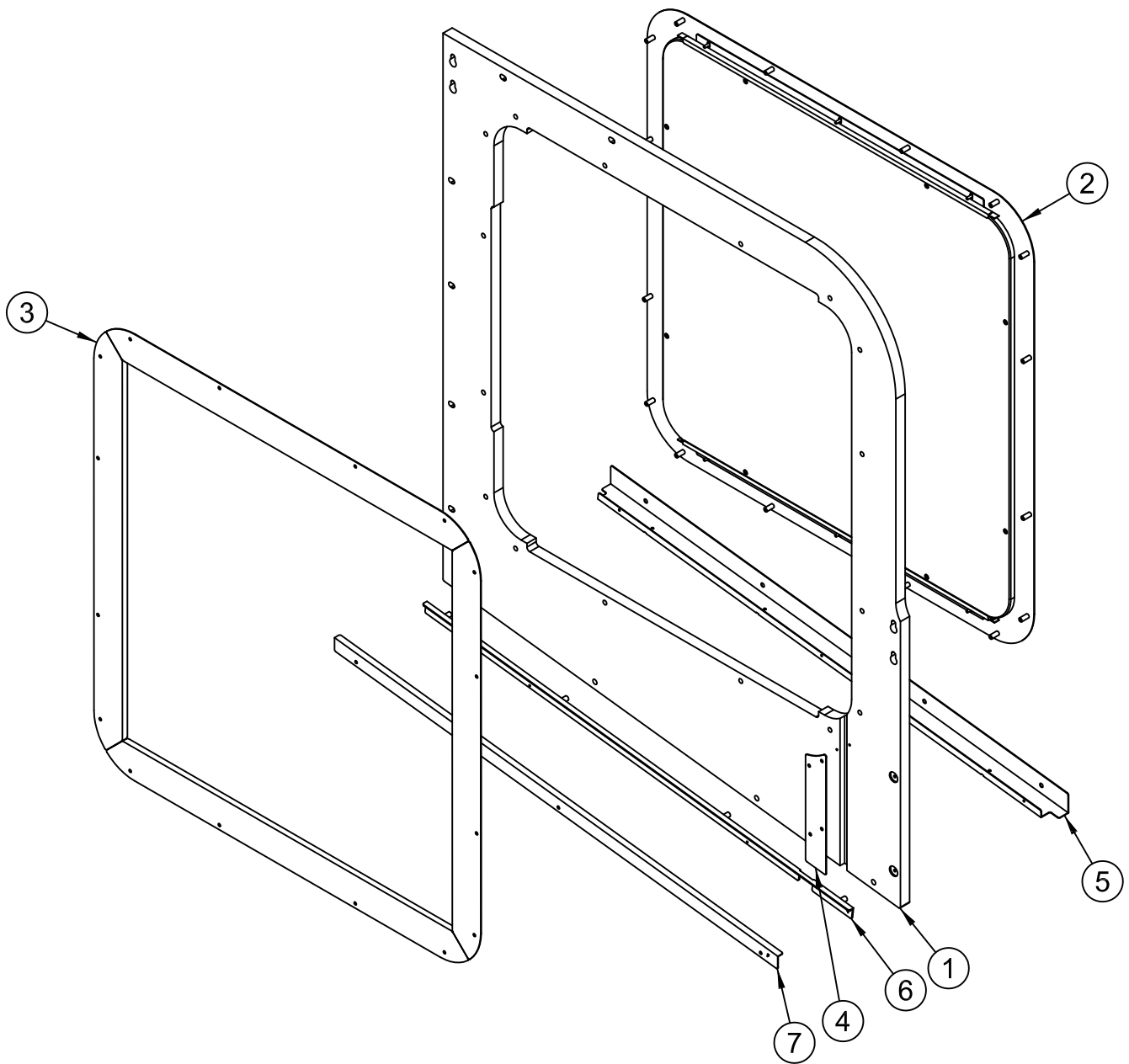

NO.	Code Number	QUANTITY	PART NAME	SPEC.
1	MPIX0WOO016	1	MIDDLE SIDE BASE PANEL_mir	MDF-20t
2	APIX0ASM026	1	MIDDLE SIDE ACRYL FRAME Ass'y	11-28. (39page)
3	MPIX0MET083	4	MIDDLE SIDE FRAME FIX BRKT A	SPCC-1.2t
4	MPIX0MET084	1	MIDDLE SIDE INNER HARNESS COVER BRKT	SPCC-1.2t
5	MPIX0MET086	1	MIDDLE SIDE PANEL OUT COVER BRKT_mir	SPCC-1.2t
6	MPIX0MET088	1	MIDDLE SIDE PANEL INNER FIX BRKT_mir	SPCC-2.0t
7	MPIX0MET090	1	MIDDLE SIDE HARNESS COVER BRKT_mir	SPCC-1.2t

11-31.PIXEL MODULE Ass'y

APIX0ASM033

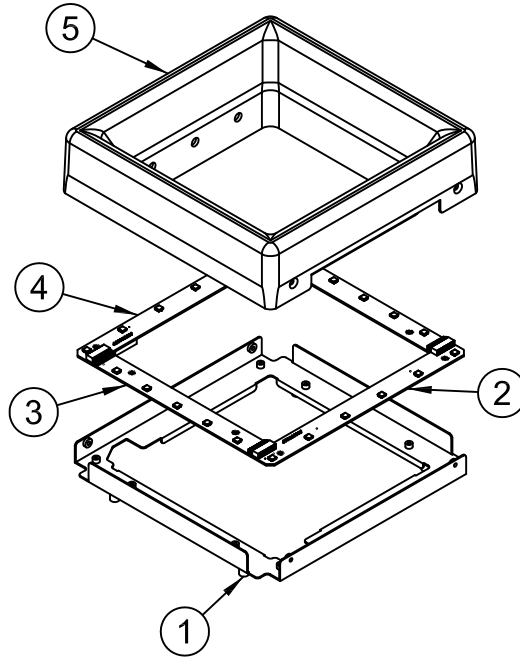

NO.	Code Number	QUANTITY	PART NAME	SPEC.
1	MPIX0MET045	1	CUBE BASKET PCB SUPPORT BRKT	SPCC-1.2t
2	APIX0BOA009	1	MODULE TX BOARD	KMSEN-1802-160B
3	APIX0BOA008	2	MODULE LED BOARD	KMSEM-1801-162A
4	APIX0BOA010	1	MODULE RX BOARD	KMSEN-1802-161B
5	MPIX0MOL001	1	PIXEL MODULE COVER	LIGHT DIFFUSION PP-6T

11-32.REAR BALL REBOUND PROTECT Ass'y

APIX0ASM035

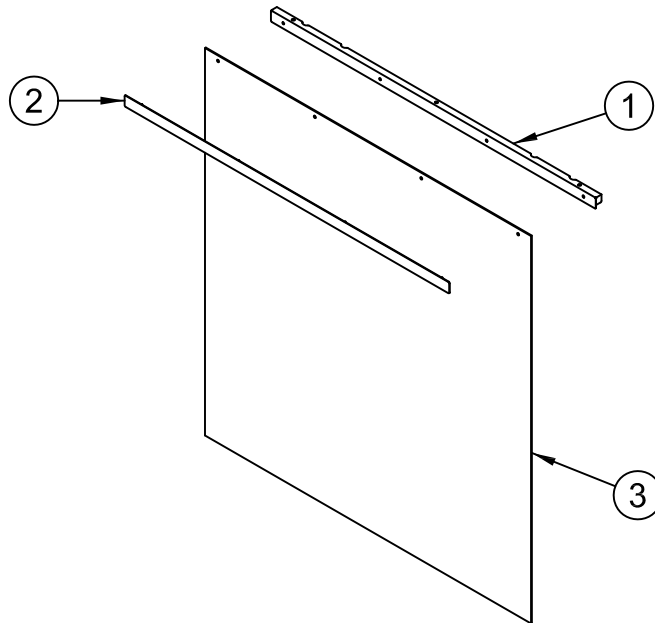

NO.	Code Number	QUANTITY	PART NAME	SPEC.
1	MPIX0MET063	1	BALL REBOUND BASE BRKT	SPCC-1.2t
2	MPIX0MET064	1	REAR BALL REBOUND SUPPORT BRKT	SPCC-1.2t
3	MPIX0000001	1	RUBBER PAD (2.4T)	EPDM RUBBER PAD 2.4T (101cm X 104cm)

11-33. BILLBOARD SIDE UPPER BALL STOP Ass'y

APIX0ASM012

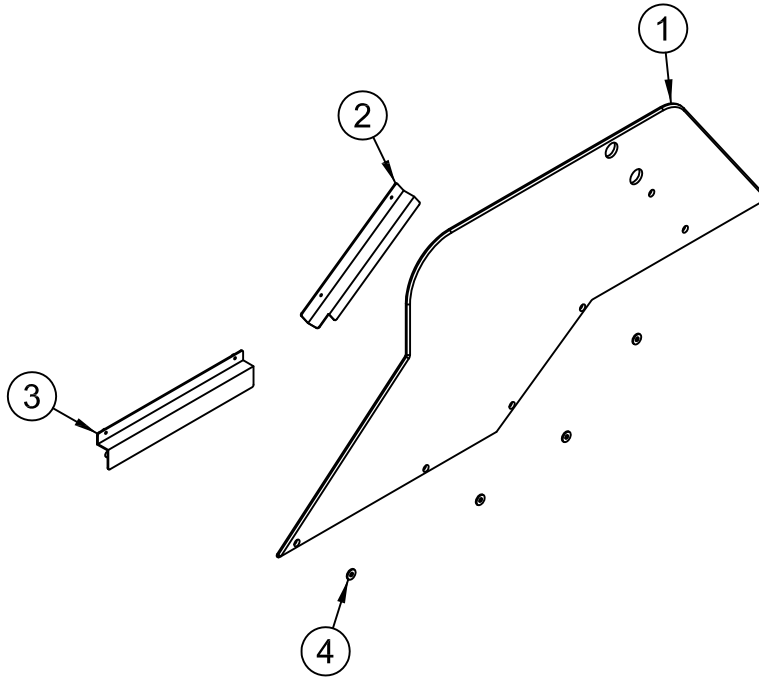

NO.	Code Number	QUANTITY	PART NAME	SPEC.
1	MPIX0A&S006	1	BILLBOARD SIDE UPPER BALL STOP ACRYL	CLEAR PC-5.0t (투명)
2	MPIX0MET097	1	BILLBOARD SIDE UPPER ANGLE FIX BRKT	SPCC-1.6t
3	MPIX0MET099	1	BILLBOARD SIDE UPPER SUPPORT BRKT	SPCC-1.6t
4	MPIX0MET039	4	M4 WHITE WASHER	SPCC-1.6t

11-34. BILLBOARD SIDE UPPER BALL STOP Ass'y_mir

APIX0ASM013

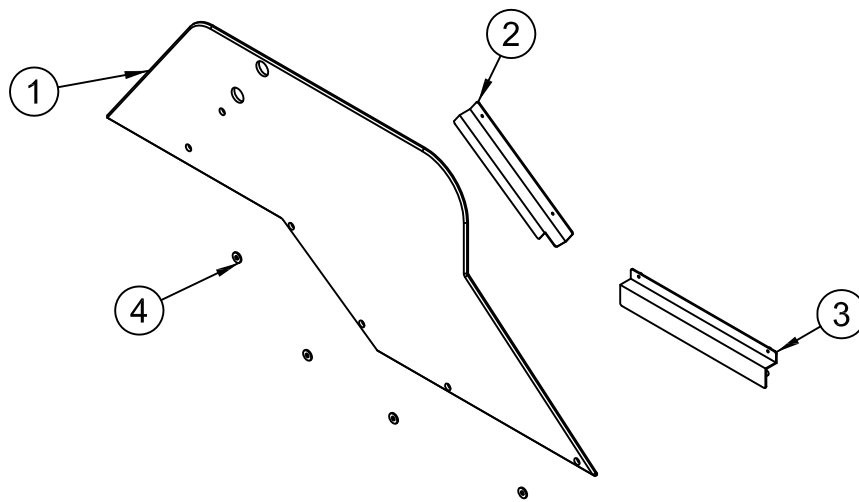

NO.	Code Number	QUANTITY	PART NAME	SPEC.
1	MPIX0A&S007	1	BILLBOARD SIDE UPPER BALL STOP ACRYL_mir	CLEAR PC-5.0t (투명)
2	MPIX0MET098	1	BILLBOARD SIDE UPPER ANGLE FIX BRKT_mir	SPCC-1.6t
3	MPIX0MET099	1	BILLBOARD SIDE UPPER SUPPORT BRKT	SPCC-1.6t
4	MPIX0MET039	4	M4 WHITE WASHER	SPCC-1.6t

11-35. BILLBOARD BACK LIGHT COVER Ass'y

APIX0ASM007

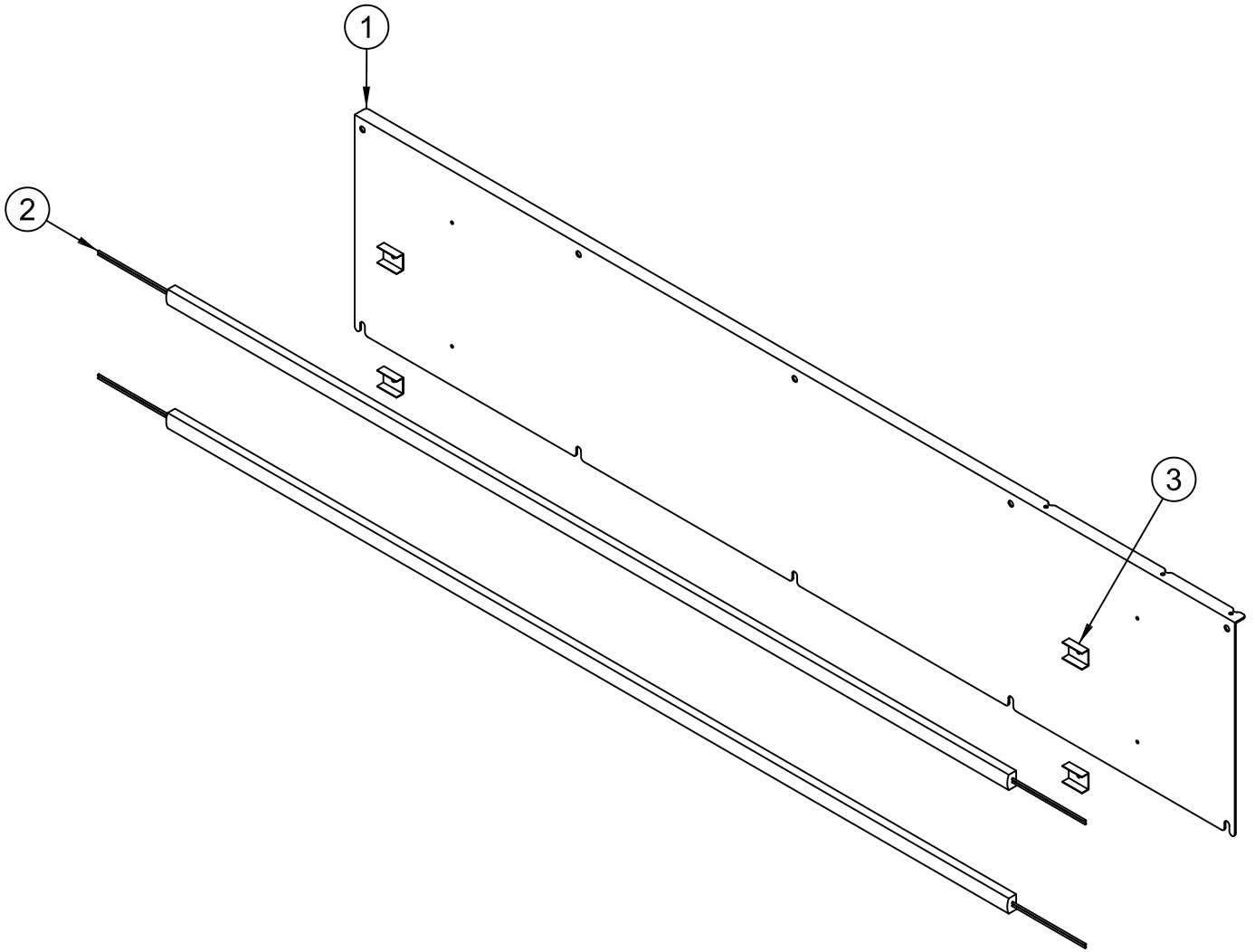

NO.	Code Number	QUANTITY	PART NAME	SPEC.
1	MPIX0MET077	1	BILLBOARD BACK LIGHT COVER BRKT	SPCC-1.2t
2	MZZZ0LSB010	2	LED(5050) STICK BAR(8.000K)- 850mm	WHITE COLOR LED (850mm)
3	MSWI0LSB002	4	LED STICK BAR BRKT 12MM	12MM

11-36. BILLBOARD BACK LIGHT Ass'y

APIX0ASM006

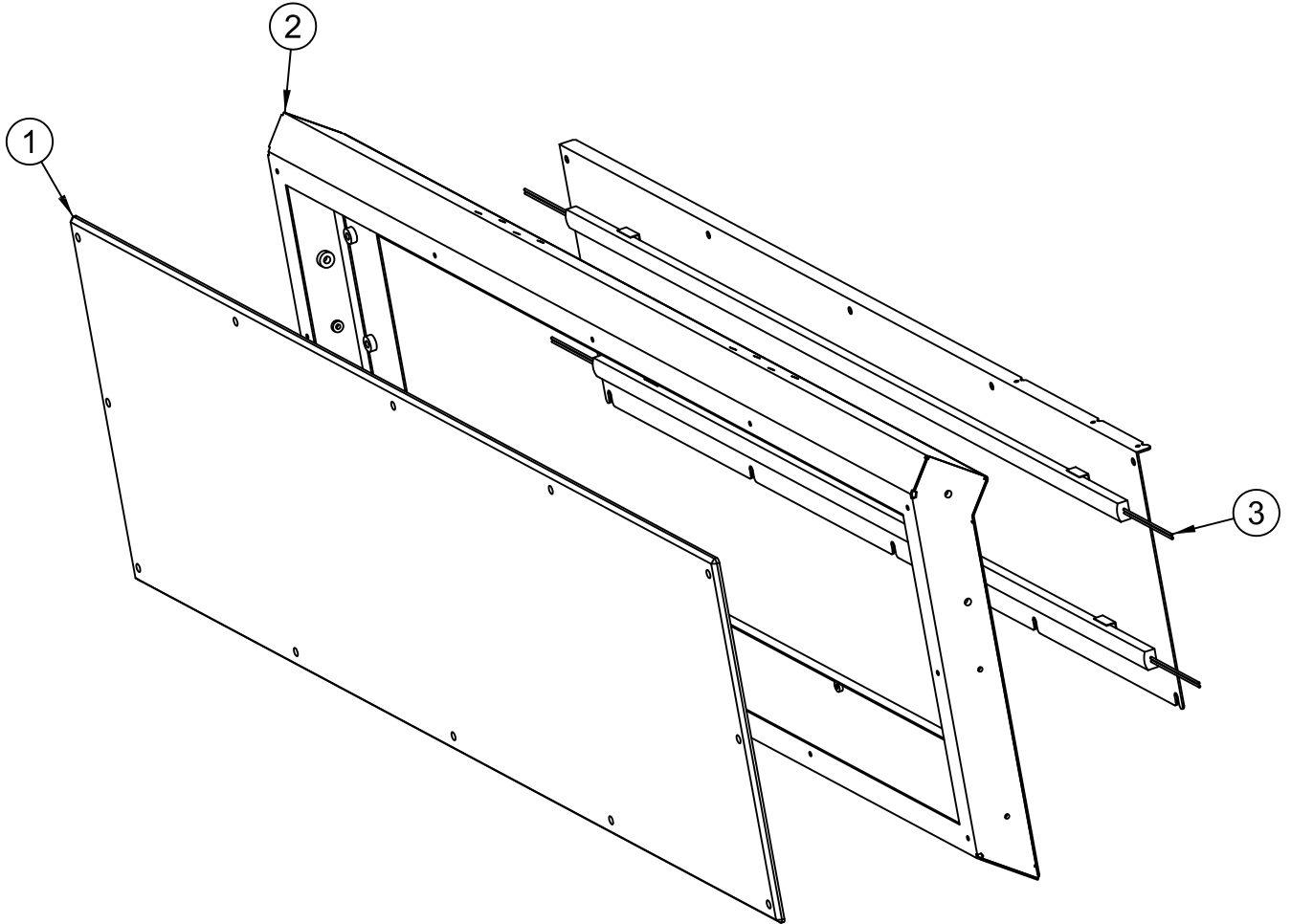

NO.	Code Number	QUANTITY	PART NAME	SPEC.
1	MPIX0A&S008	1	BILLBOARD BACK LIGHT PC COVER ACRYL	CLEAR PC-5.0t (투명)
2	MPIX0MET073	1	BILLBOARD BACK LIGHT FRAME WELD Ass'y	WELD Ass'y (용접물)
3	APIX0ASM007	1	BILLBOARD BACK LIGHT COVER Ass'y	11-35. (44page)

11-37. BILLBOARD CENTER Ass'y

APIX0ASM009

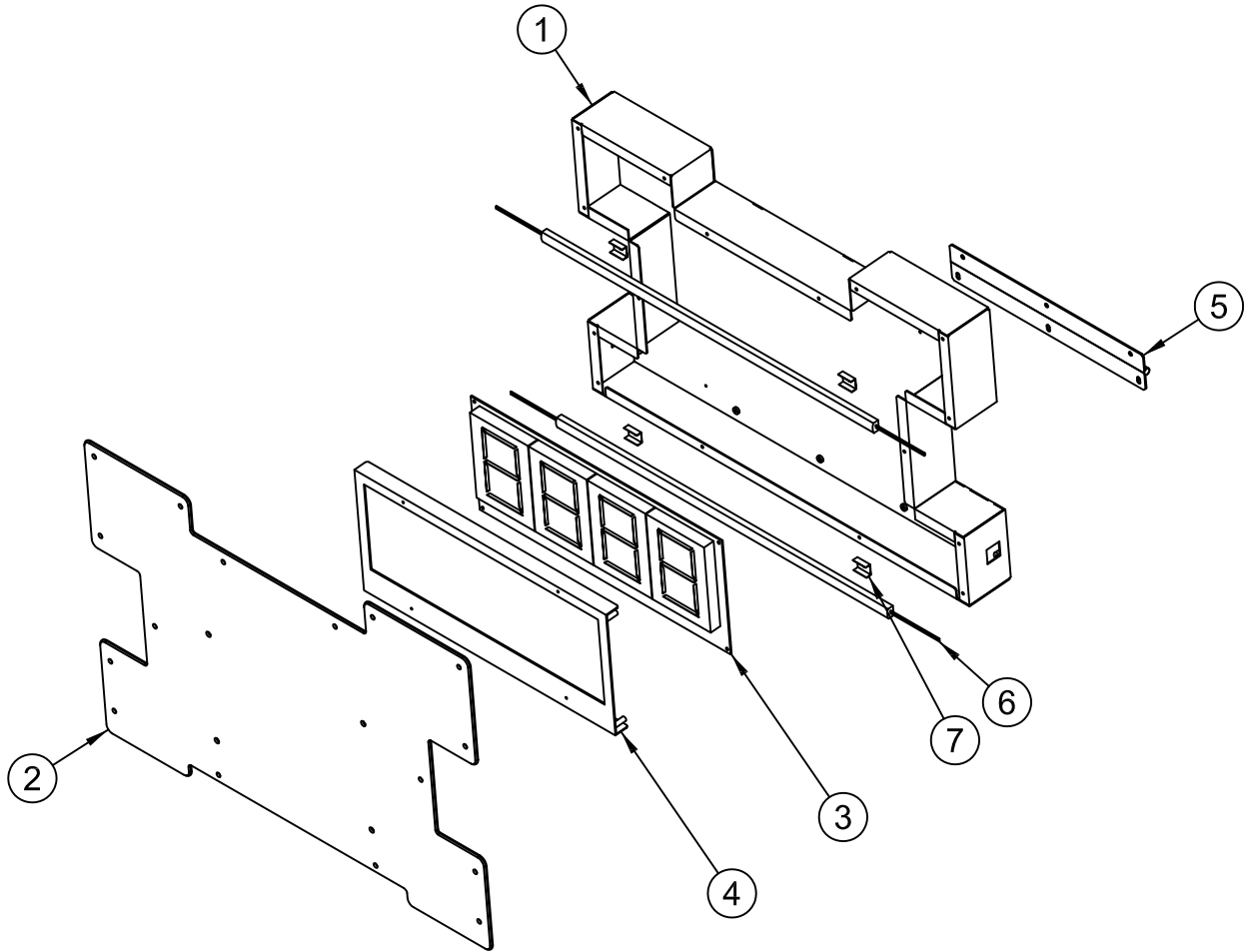

NO.	Code Number	QUANTITY	PART NAME	SPEC.
1	MPIX0MET066	1	BILLBOARD CENTER FRAME WELD Ass'y	WELD Ass'y (용접물)
2	MPIX0A&S009	1	BILLBOARD CENTER FRAME COVER ACRYL	CLEAR PC-3.0t (투명)
3	APIX0BOA006	1	BIG BONUS FND	KMFND-1706-141A
4	MPIX0MET067	1	BILLBOARD BONUS FND FIX BRKT	SPCC-1.6t
5	MPIX0MET075	1	BILLBOARD CENTER HINGE Ass'y	SPCC-1.6t
6	MZZZ0LSB003	2	LED(5050) STICK BAR(8.000K)-500mm	WHITE COLOR LED (500mm)
7	MSWI0LSB002	4	LED STICK BAR BRKT 12MM	12MM

11-38.BILLBOARD SIDE LIGHT ACRYL Ass'y (UP RED)

APIX0ASM047

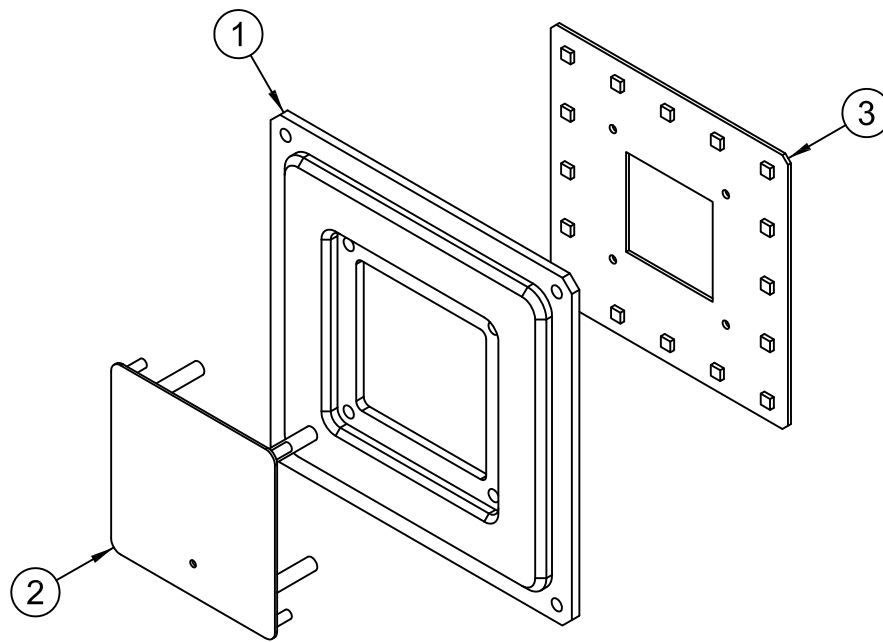

NO.	Code Number	QUANTITY	PART NAME	SPEC.
1	MPIX0ACR008	1	BILLBOARD SIDE LIGHT ACRYL	POINT ACRYL -10t
2	MPIX0MET069	1	BILLBOARD SIDE ACRYL BOARD SUPPORT BRKT	SPCC-1.2t
3	APIX0BOA005	1	BILLBOARD SIDE LED BOARD (RED)	KMLED01710-153A

11-39.BILLBOARD SIDE LIGHT ACRYL Ass'y (DOWN BLUE)

APIX0ASM048

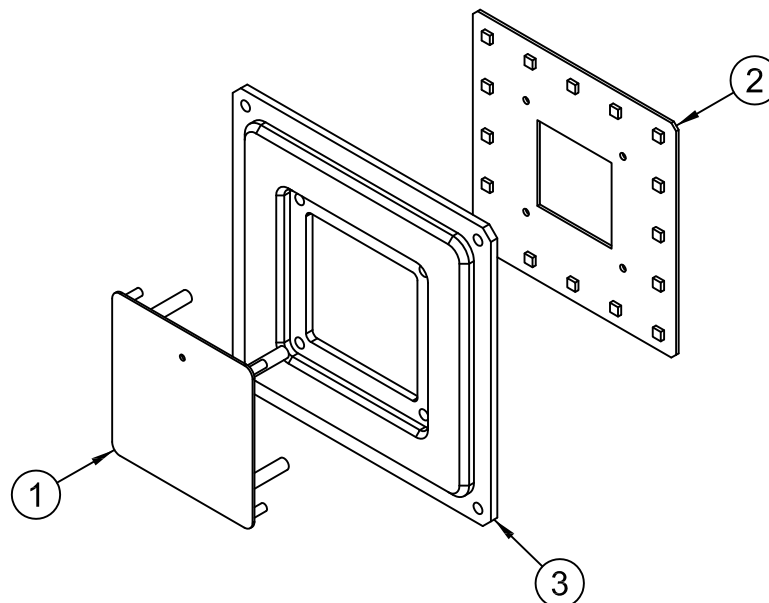

NO.	Code Number	QUANTITY	PART NAME	SPEC.
1	MPIX0MET069	1	BILLBOARD SIDE ACRYL BOARD SUPPORT BRKT	SPCC-1.2t
2	APIX0BOA004	1	BILLBOARD SIDE LED BOARD (BLUE)	KMLED01710-153A
3	MPIX0ACR008	1	BILLBOARD SIDE LIGHT ACRYL	POINT ACRYL -10t

11-40.BILLBOARD SIDE Ass'y

APIX0ASM010

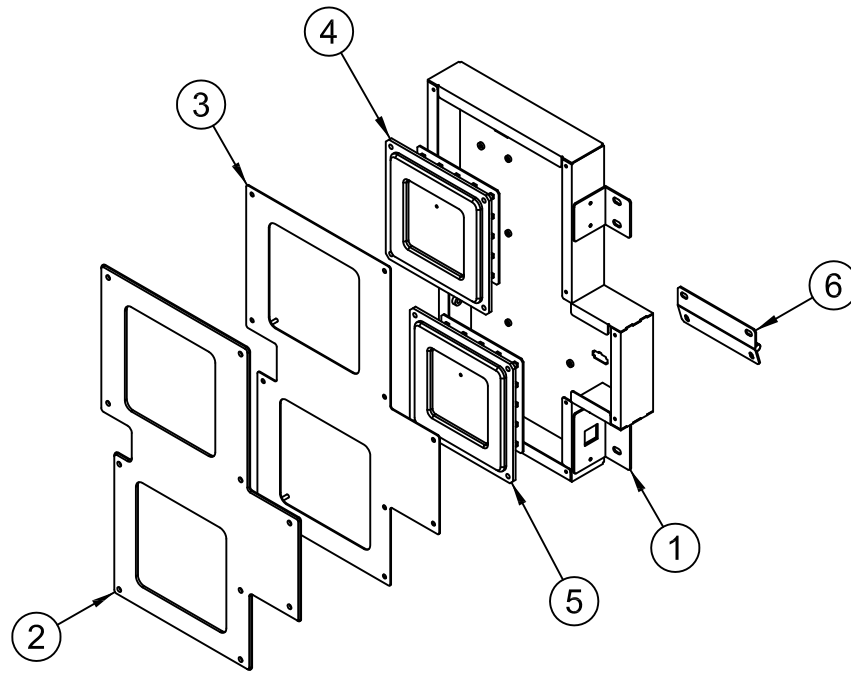

NO.	Code Number	QUANTITY	PART NAME	SPEC.
1	MPIX0MET068	1	BILLBOARD SIDE FRAME WELD Ass'y	WELD Ass'y (용접물)
2	MPIX0A&S010	1	BILLBOARD SIDE FRAME COVER ACRYL	CLEAR PC-3.0t (투명)
3	MPIX0MET070	1	BILLBOARD SIDE FRAME FRONT COVER BRKT	SPCC-1.2t
4	APIX0ASM047	1	BILLBOARD SIDE LIGHT ACRYL Ass'y (UP RED)	11-38. (47page)
5	APIX0ASM048	1	BILLBOARD SIDE LIGHT ACRYL Ass'y (DOWN BLUE)	11-39. (47page)
6	MPIX0MET074	1	BILLBOARD HINGE Ass'y	SPCC-1.6t

11-41.BILLBOARD SIDE Ass'y_mir

APIX0ASM011

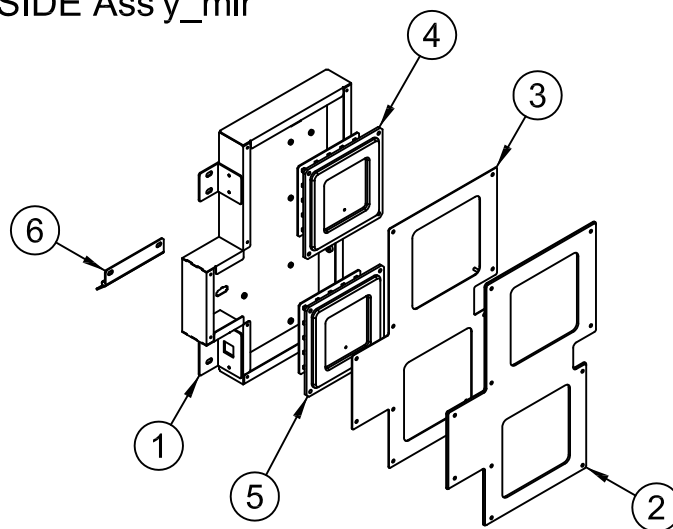

NO.	Code Number	QUANTITY	PART NAME	SPEC.
1	MPIX0MET072	1	BILLBOARD SIDE FRAME WELD Ass'y_mir	WELD Ass'y (용접물)
2	MPIX0A&S011	1	BILLBOARD SIDE FRAME COVER ACRYL_mir	CLEAR PC-3.0t (투명)
3	MPIX0MET071	1	BILLBOARD SIDE FRAME FRONT COVER BRKT_mir	SPCC-1.2t
4	APIX0ASM047	1	BILLBOARD SIDE LIGHT ACRYL Ass'y (UP RED)	11-38. (47page)
5	APIX0ASM048	1	BILLBOARD SIDE LIGHT ACRYL Ass'y (DOWN BLUE)	11-39. (47page)
6	MPIX0MET074	1	BILLBOARD HINGE Ass'y	SPCC-1.6t

11-42. BILLBOARD BONUS FND Ass'y

APIX0ASM008

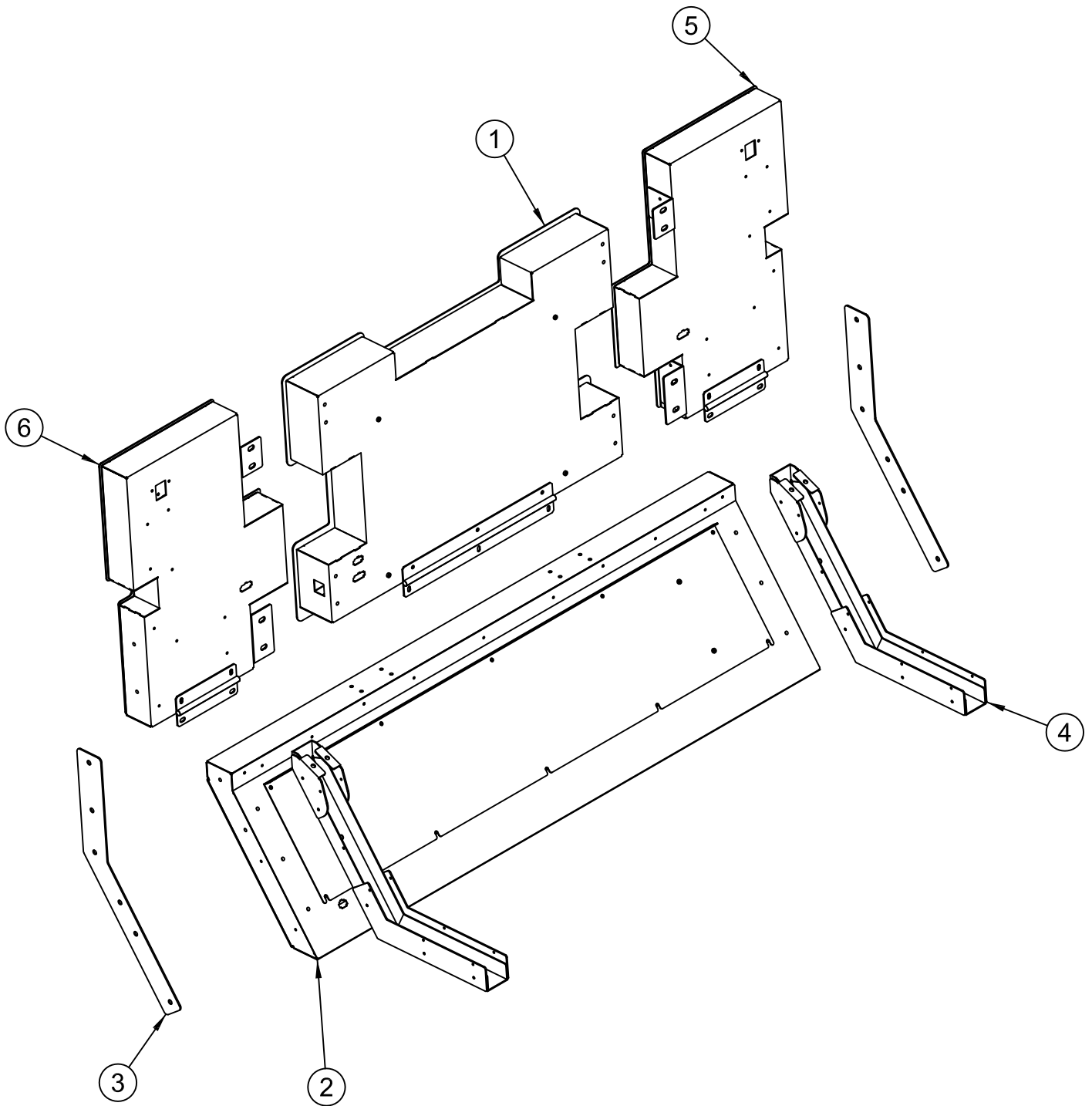

NO.	Code Number	QUANTITY	PART NAME	SPEC.
1	APIX0ASM009	1	BILLBOARD CENTER Ass'y	11-37. (46page)
2	APIX0ASM006	1	BILLBOARD BACK LIGHT Ass'y	11-36. (45page)
3	MPIX0MET078	2	BILLBOARD Ass'y SIDE SUPPORT BRKT	SPCC-2t
4	MPIX0MET079	2	BILLBOARD FIX BRKT WELD Ass'y	WELD Ass'y(용접물)
5	APIX0ASM010	1	BILLBOARD SIDE Ass'y	11-40. (48page)
6	APIX0ASM011	1	BILLBOARD SIDE Ass'y_mir	11-41. (48page)

11-43.CASTER Ass'y

APIX0ASM016

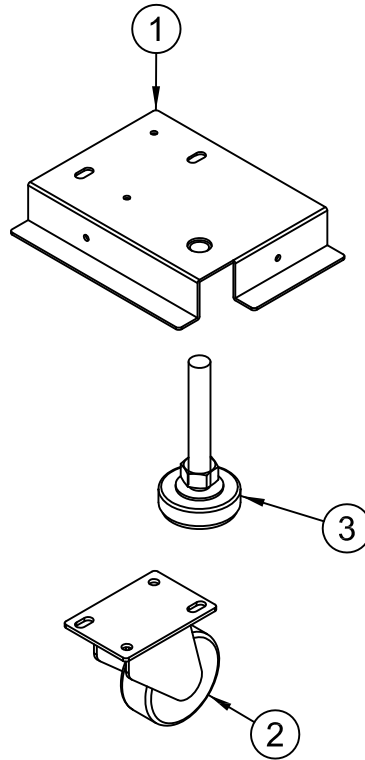

NO.	Code Number	QUANTITY	PART NAME	SPEC.
1	MPIX0WOO005	1	CASTER BRKT WELD Ass'y	PAINTING BLACK COLOR (흑색유광도장)
2	MZZZ0CAS010	1	CASTER	3inch
3	MZZZ0ADJ001	1	ADJUSTER (PV-100-60)	(PV-100-60)

11-44.CASTER Ass'y_mir

APIX0ASM017

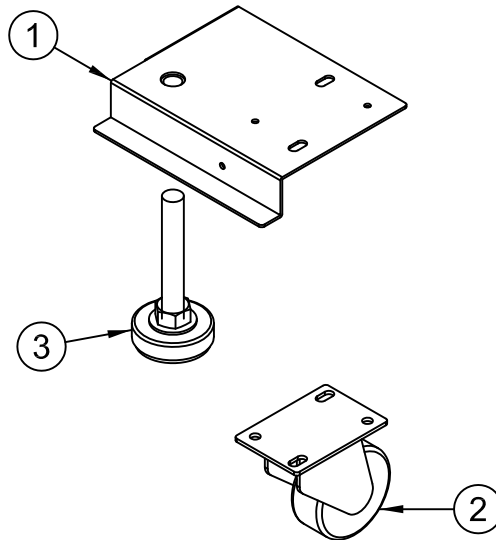

NO.	Code Number	QUANTITY	PART NAME	SPEC.
1	MPIX0WOO006	1	CASTER BRKT WELD Ass'y_mir	PAINTING BLACK COLOR (흑색유광도장)
2	MZZZ0CAS010	1	CASTER	3inch
3	MZZZ0ADJ001	1	ADJUSTER (PV-100-60)	(PV-100-60)

11-45.FRONT CABINET Ass'y

APIX0ASM019

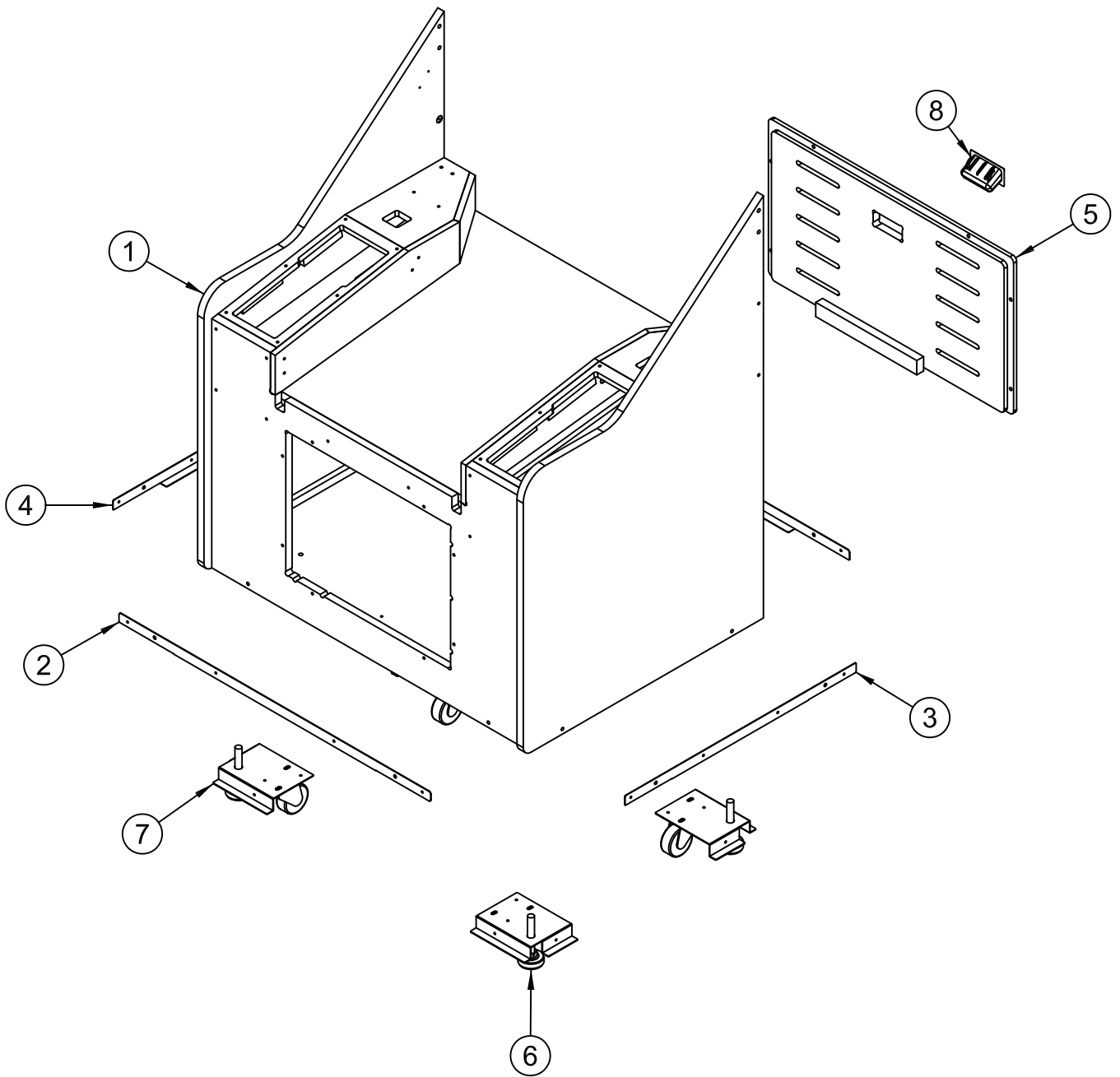

NO.	Code Number	QUANTITY	PART NAME	SPEC.
1	MPIX0WOO003	1	FRONT WOOD Ass'y	ASSEMBLE (조립품)
2	MPIX0WOO007	2	FRONT BENDING	SPCC-1.2t
3	MPIX0WOO008	1	FRONT SIDE BENDING	SPCC-1.2t
4	MPIX0WOO009	1	FRONT SIDE BENDING_mir	SPCC-1.2t
5	MPIX0WOO004	1	FRONT CASE DOOR	MDF-20t
6	APIX0ASM016	2	CASTER Ass'y	11-43. (50page)
7	APIX0ASM017	2	CASTER Ass'y_mir	11-44. (50page)
8	MSBC0WOO014	1	PLASTIC DRAWER PULLS	BLACK PLASTIC

11-46. FRONT CASE Ass'y

APIX0ASM020

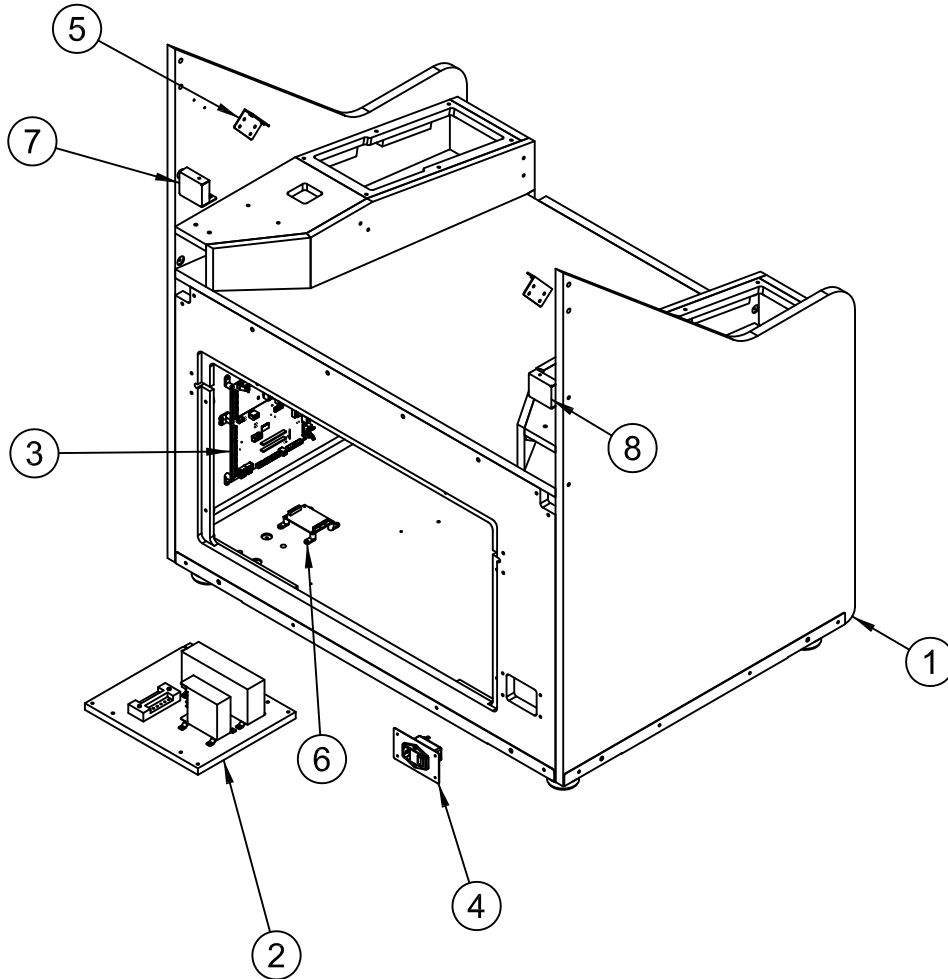

NO.	Code Number	QUANTITY	PART NAME	SPEC.
1	APIX0ASM019	1	FRONT CABINET Ass'y	11-45. (51page)
2	APIX0ASM034	1	POWER SMPS Ass'y	11-2. (22page)
3	APIX0ASM032	1	PIXEL MAIN BOARD Ass'y	11-4. (23page)
4	APIX0ASM030	1	NOISE FILTER Ass'y	11-3. (23page)
5	MPIX0MET041	2	FRONT SCORE FND ACRYL FIX BRKT	SPCC-1.6t
6	AUFE0PCB002	1	PWM 3 POINT LED BOARD	KMPWM-1303-38B
7	MPIX0MET042	1	FRONT UPPER MIDDLE PANEL LINK BRKT	SPCC-1.6t
8	MPIX0MET043	1	FRONT UPPER MIDDLE PANEL LINK BRKT_mir	SPCC-1.6t

11-47.FRONT CASE Ass'y

APIX0ASM020

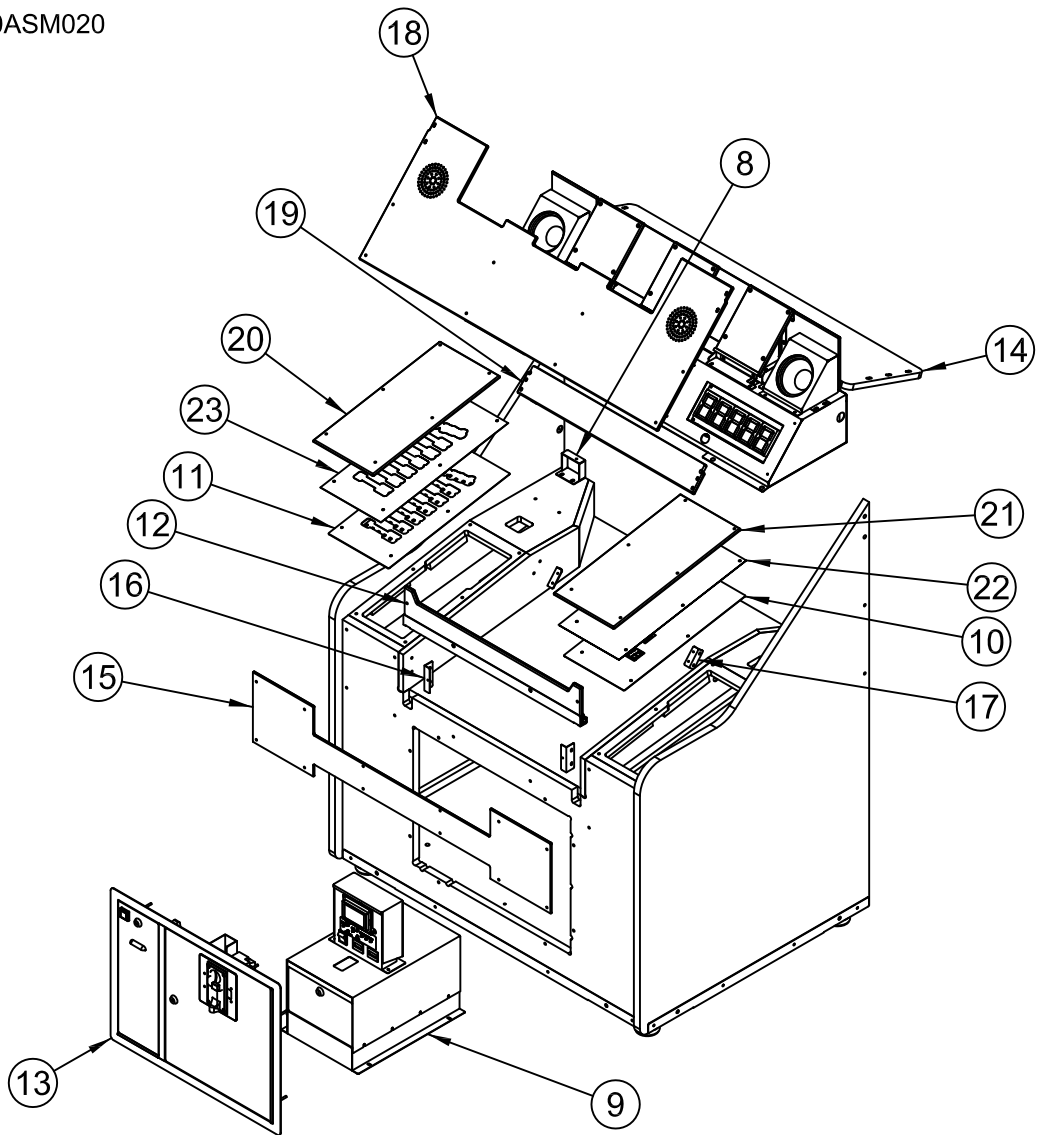

NO.	Code Number	QUANTITY	PART NAME	SPEC.
9	APIX0ASM015	1	CASH BOX BODY Ass'y	11-6. (24page)
10	APIX0ASM018	1	CREDIT FND Ass'y	11-26. (37page)
11	APIX0ASM022	1	FRONT SCORE TICKET Ass'y	11-25. (37page)
12	APIX0ASM023	1	FRONT TITLE ACRYL Ass'y	11-7. (25page)
13	APIX0ASM021	1	FRONT MIDDLE DOOR ASSY	11-24. (36page)
14	APIX0ASM040	1	SCORE FND BOX Ass'y	11-22. (34page)
15	MPIX0A&S001	1	FRONT DECO ACRYL	CLEAR ACRYL-5t (투명아크릴)
16	MPIX0MET040	2	FRONT TITLE ACRYL SIDE FIX BRKT	SPCC-1.2t
17	MPIX0MET044	2	SCORE BOX BOTTOM ACRYL FIX BRKT	SPCC-2t
18	MPIX0A&S004	1	FRONT CASE SCORE FND ACRYL	CLEAR ACRYL-8t (투명아크릴)
19	MPIX0A&S003	1	SCORE BOX BOTTOM LED ACRYL	CLEAR ACRYL - 10.0t (투명아크릴)
20	MPIX0ACR001	1	SCORE TICKET COVER ACRYL	CLEAR ACRYL-5.0t (투명아크릴)
21	MPIX0ACR002	1	CREDIT COVER ACRYL	CLEAR ACRYL-5.0t (투명아크릴)
22	MPIX0SHE039	1	CREDIT COVER ACRYL SHEET	LIGHTING SHEET+FND FILM
23	MPIX0SHE040	1	SCORE TICKET COVER ACRYL SHEET	EMEA DEFAULT
	MPIX0SHE041	1	SCORE TICKET COVER ACRYL SHEET	US DEFAULT
	MPIX0SHE042	1	SCORE TICKET COVER ACRYL SHEET	ADDITIONAL

11-48. REAR CABINET Ass'y

APIX0ASM036

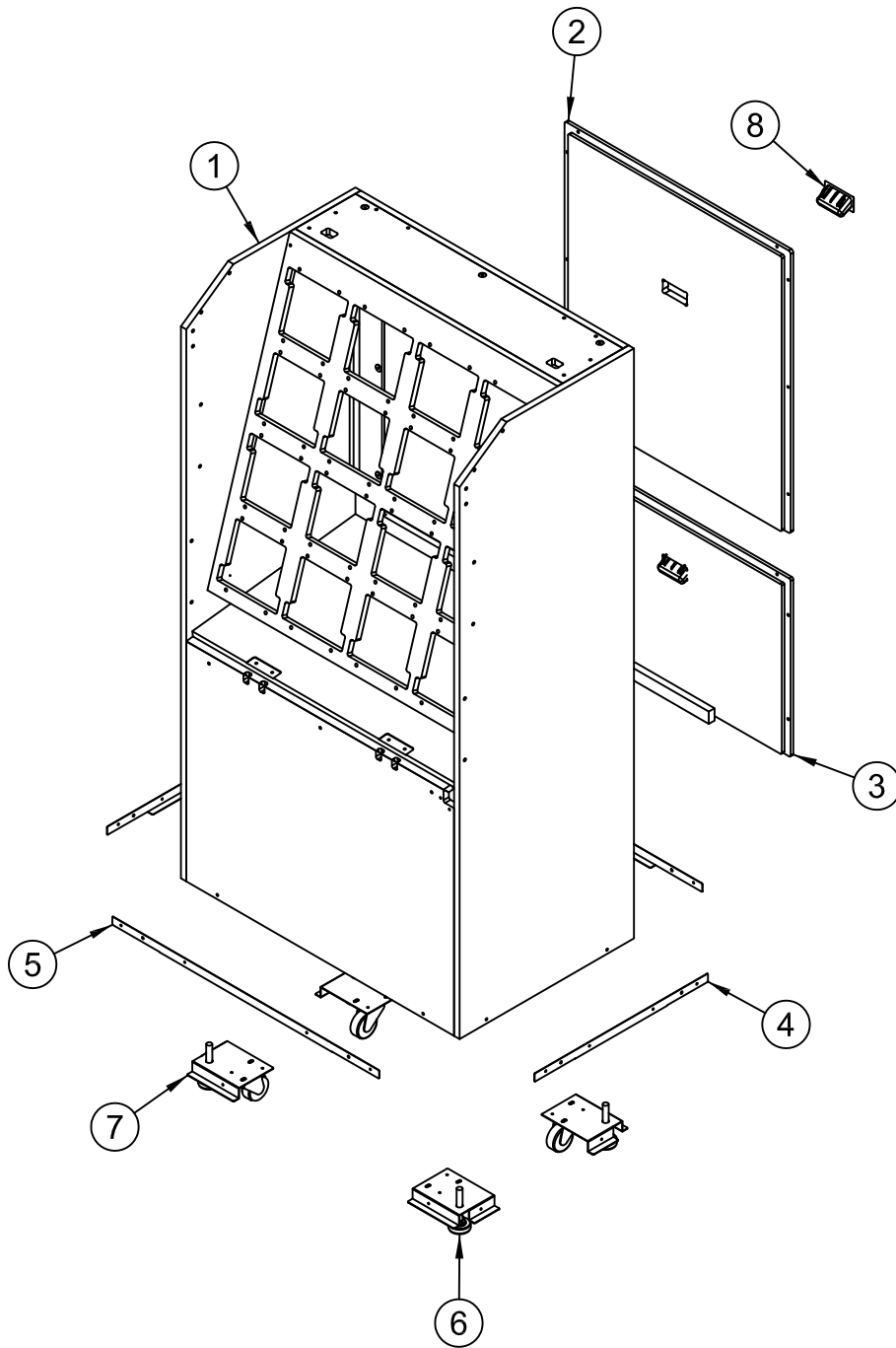

NO.	Code Number	QUANTITY	PART NAME	SPEC.
1	MPIX0WOO010	1	REAR WOOD Ass'y	ASSEMBLE (조립품)
2	MPIX0WOO011	1	REAR DOOR	MDF-20t
3	MPIX0WOO012	1	REAR BACK BOTTOM DOOR	MDF- 20t
4	MPIX0WOO013	2	REAR SIDE BENDING	SPCC-1.2t
5	MPIX0WOO014	2	REAR FRONT BENDING	SPCC-1.2t
6	APIX0ASM016	2	CASTER Ass'y	11-43. (50page)
7	APIX0ASM017	2	CASTER Ass'y_mir	11-44. (50page)
8	MSBC0WOO014	2	PLASTIC DRAWER PULLS	BLACK PLASTIC

11-49. REAR CASE. Ass'y

APIX0ASM037

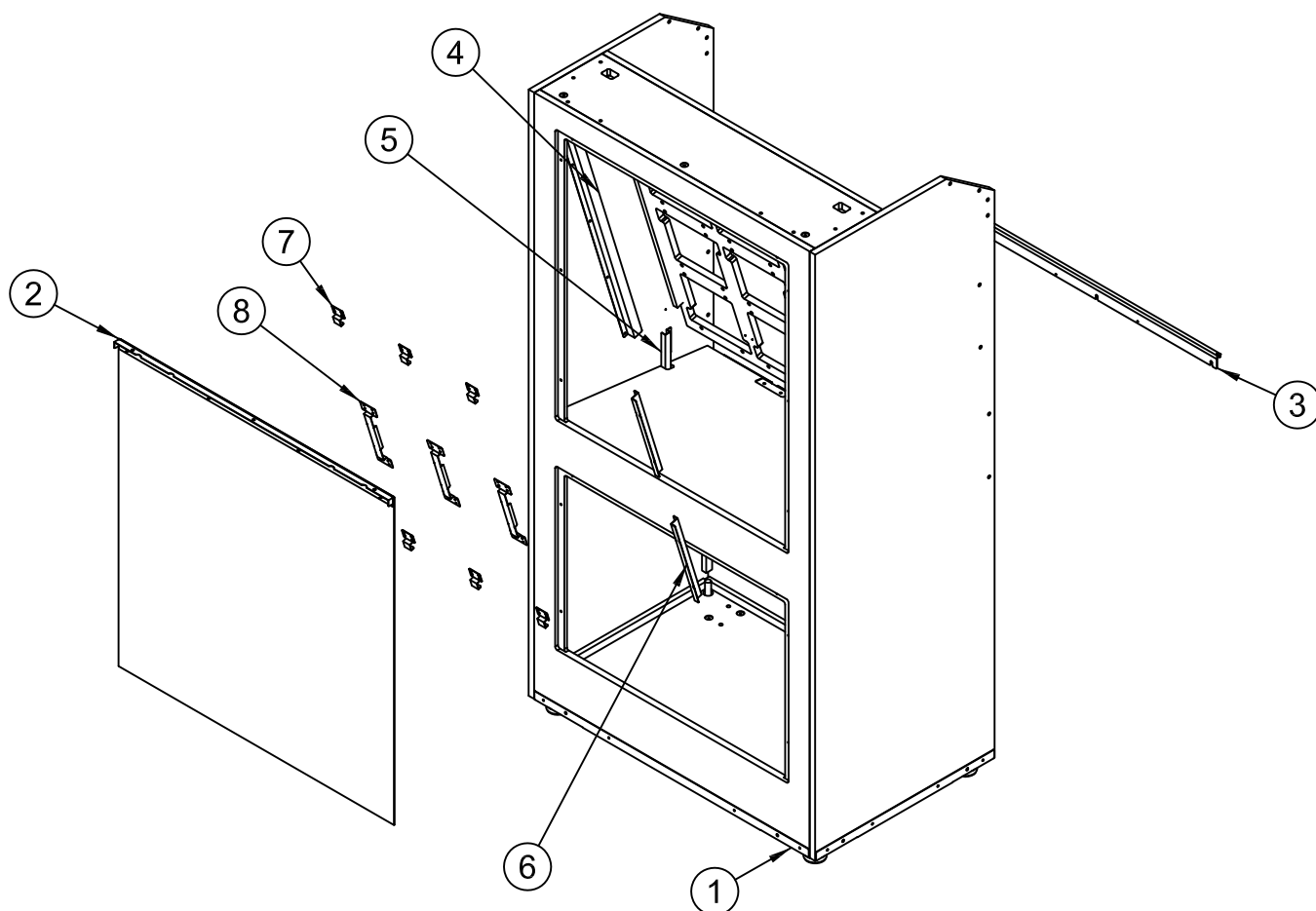

NO.	Code Number	QUANTITY	PART NAME	SPEC.
1	APIX0ASM036	1	REAR CABINET Ass'y	11-48. (54page)
2	APIX0ASM035	1	REAR BALL REBOUND PROTECT Ass'y	11-32. (42page)
3	MPIX0MET052	1	MIDDLE WOOD PANEL BOTTOM SUPPORT BRKT	SPCC-2t
4	MPIX0MET054	1	REAR SIDE HARNESS COVER BRKT	SPCC-1.2t
5	MPIX0MET055	1	REAR MODULE HARNESS BRKT	SPCC-1.2t
6	MPIX0MET062	2	MODULE HARNESS COVER BRKT C (KOR)	SPCC-1.2t
7	MPIX0MET100	6	MODULE HARNESS COVER BRKT A	SPCC-1.2t
8	MPIX0MET101	3	MODULE HARNESS COVER BRKT B	SPCC-1.2t

11-50. REAR CASE. Ass'y

APIX0ASM037

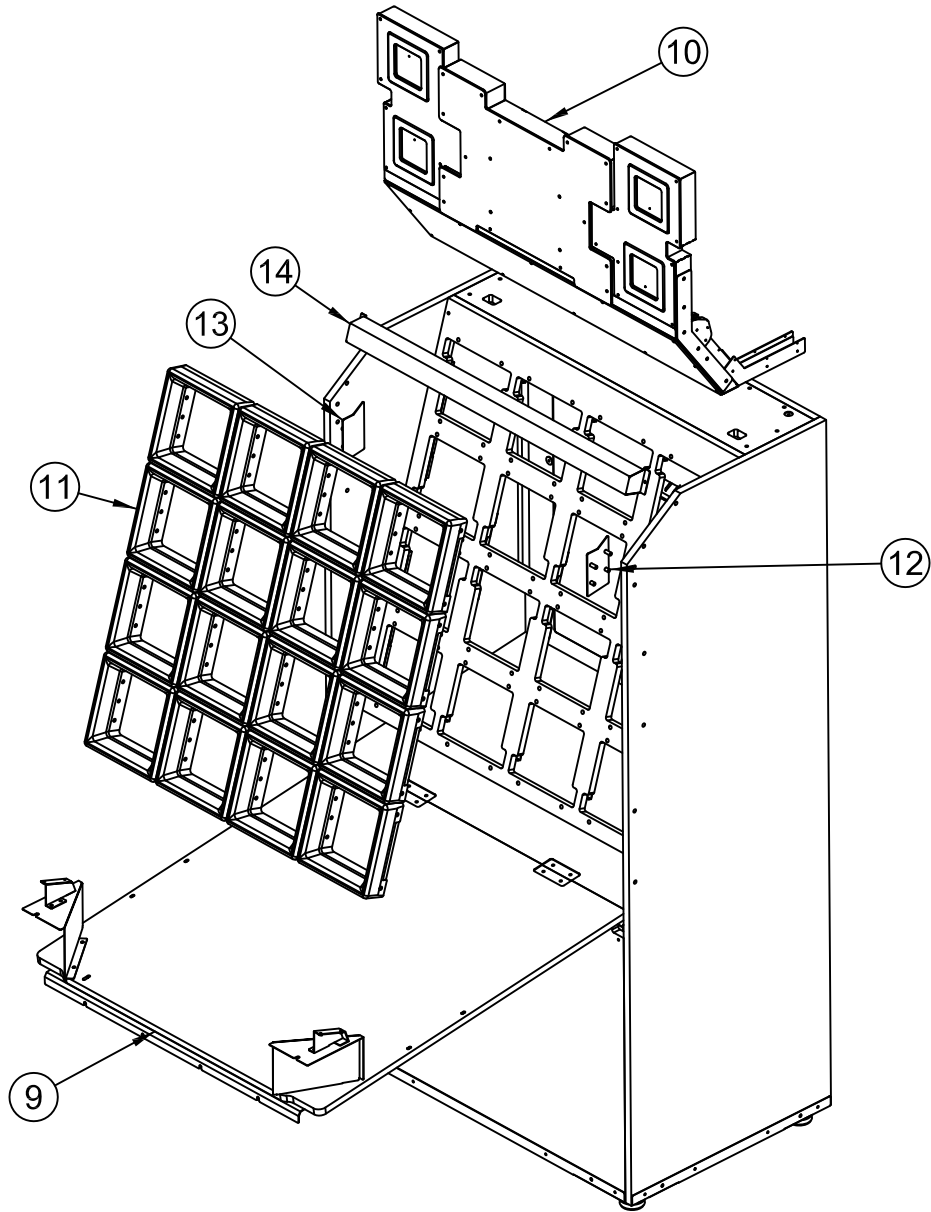

NO.	Code Number	QUANTITY	PART NAME	SPEC.
9	APIX0ASM029	1	MIDDLE WOOD PANEL Ass'y	11-27. (38page)
10	APIX0ASM008	1	BILLBOARD BONUS FND Ass'y	11-42. (49page)
11	APIX0ASM033	16	PIXEL MODULE Ass'y	11-31.(42page)
12	MPIX0MET059	1	MIDDLE REAR LINK INNER BRKT	SPCC-2t
13	MPIX0MET060	1	MIDDLE REAR LINK INNER BRKT_mir	SPCC-2t
14	MPIX0MET080	1	CUBE BASKET BALL STOP PROTECT BRKT	SPCC-1.2t

11-51. ASSEMBLING PIXEL CHASE ALL FIX Ass'y

APIX0ASM031

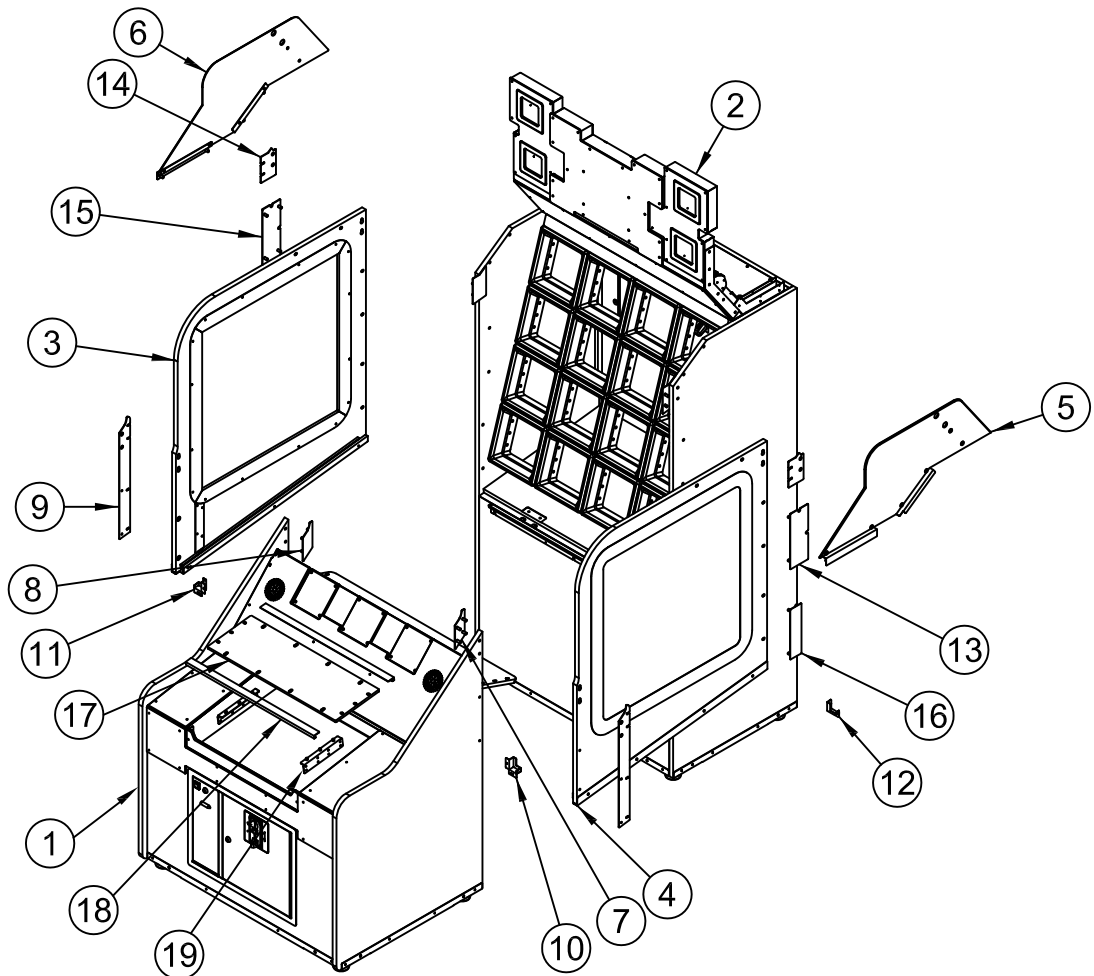

NO.	Code Number	QUANTITY	PART NAME	SPEC.
1	APIX0ASM020	1	FRONT CASE Ass'y	11-46. (52page)
2	APIX0ASM037	1	REAR CASE. Ass'y	11-49. (55page)
3	APIX0ASM027	1	MIDDLE SIDE PANEL Ass'y	11-29. (40page)
4	APIX0ASM028	1	MIDDLE SIDE PANEL Ass'y_mir	11-30. (41page)
5	APIX0ASM012	1	BILLBOARD SIDE UPPER BALL STOP Ass'y	11-33. (43page)
6	APIX0ASM013	1	BILLBOARD SIDE UPPER BALL STOP Ass'y_mir	11-34. (43page)
7	MPIX0MET091	1	FRONT MIDDLE LINK INNER BRKT	SPCC-2t
8	MPIX0MET092	1	FRONT MIDDLE LINK INNER BRKT_mir	SPCC-2t
9	MPIX0MET093	2	FRONT MIDDLE SIDE LINK BRKT	SPCC-2t
10	MPIX0MET094	1	FRONT CASE HARNESS COVER BRKT	SPCC-1.2t
11	MPIX0MET095	1	FRONT CASE HARNESS COVER BRKT _mir	SPCC-1.2t
12	MPIX0MET096	1	REAR CASE HARNESS COVER BRKT	SPCC-1.2t
13	MPIX0MET056	1	MIDDLE REAR CASE LINK OUT BRKT	SPCC-2t
14	MPIX0MET061	2	REAR MIDDLE LINK TOP BRKT	SPCC-2t
15	MPIX0MET057	1	MIDDLE REAR CASE LINK OUT BRKT _mir	SPCC-2t
16	MPIX0MET058	2	REAR MIDDLE CASE SIDE LINK BRKT A	SPCC-2t
17	MPIX0ACR011	1	FRONT BALL PROTECT PC ACRYL	CLEAR PC - 8.0t
18	MPIX0MET117	2	FRONT BALL PROTECT ACRYL SUPPORT BRKT	SPCC-1.6t
19	MPIX0MET118	2	FRONT BALL PROTECT ACRYL FIX BRKT	SPCC-2t

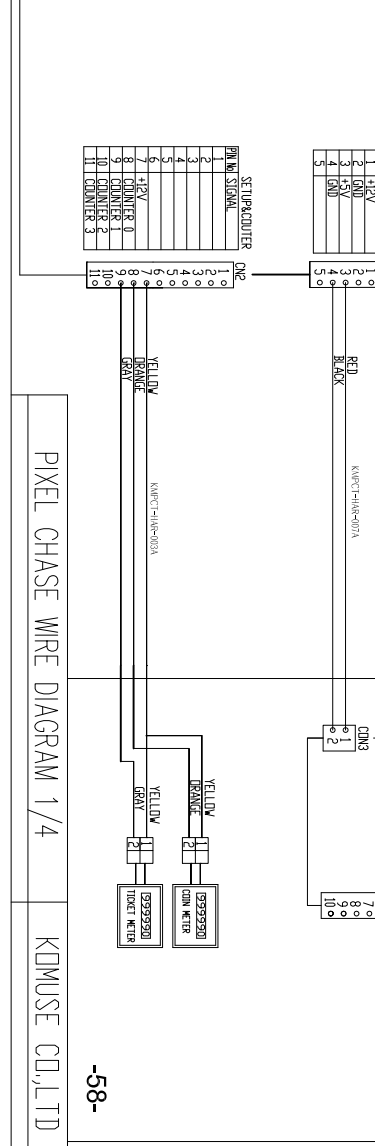
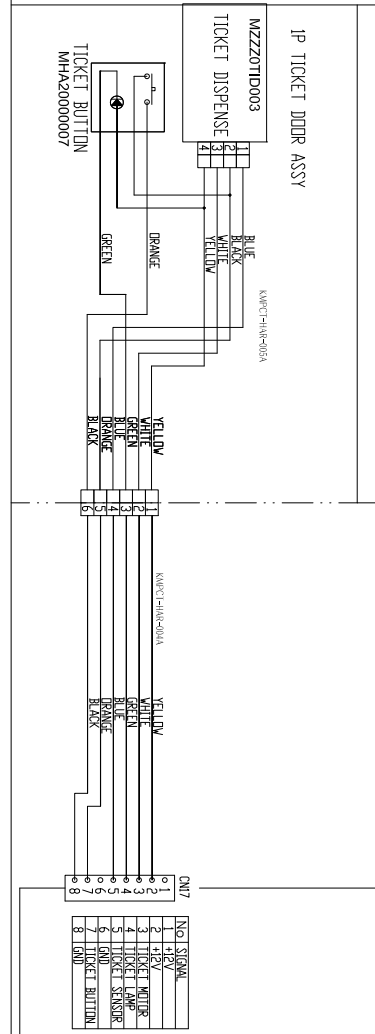
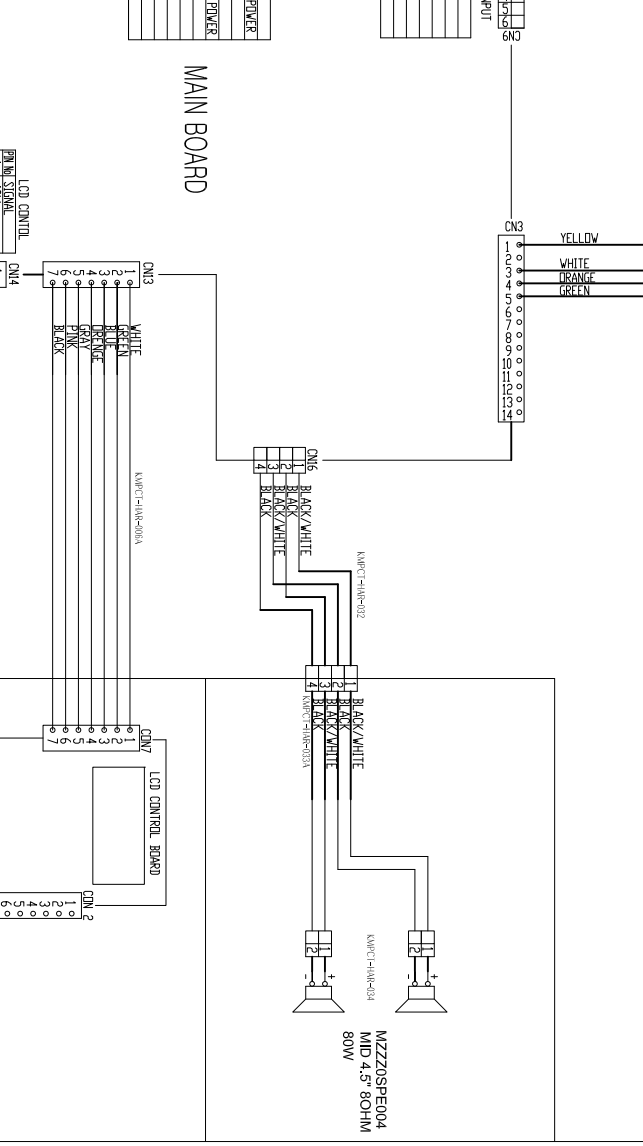
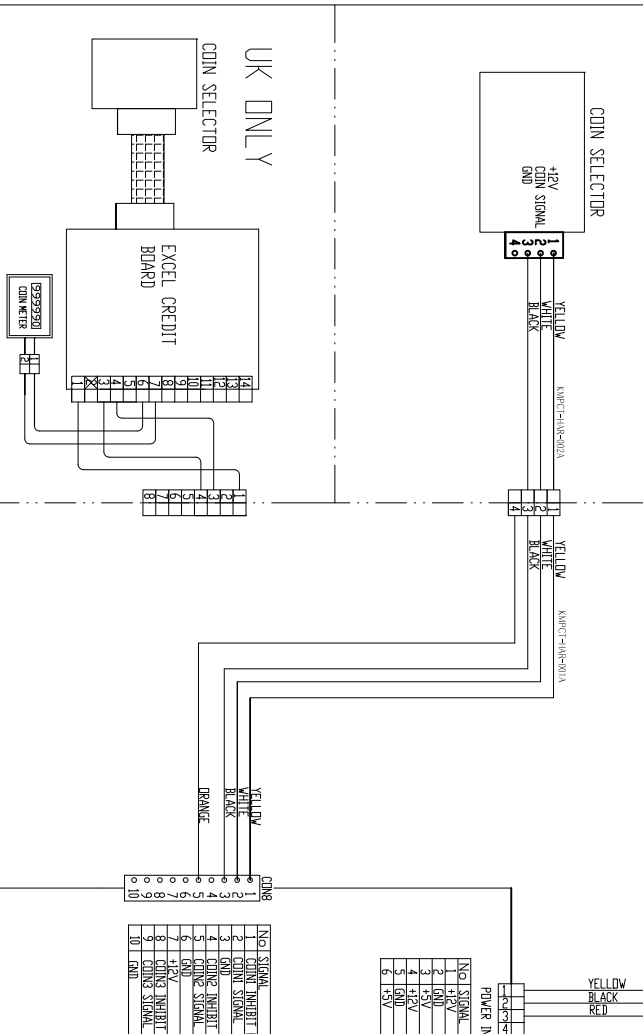
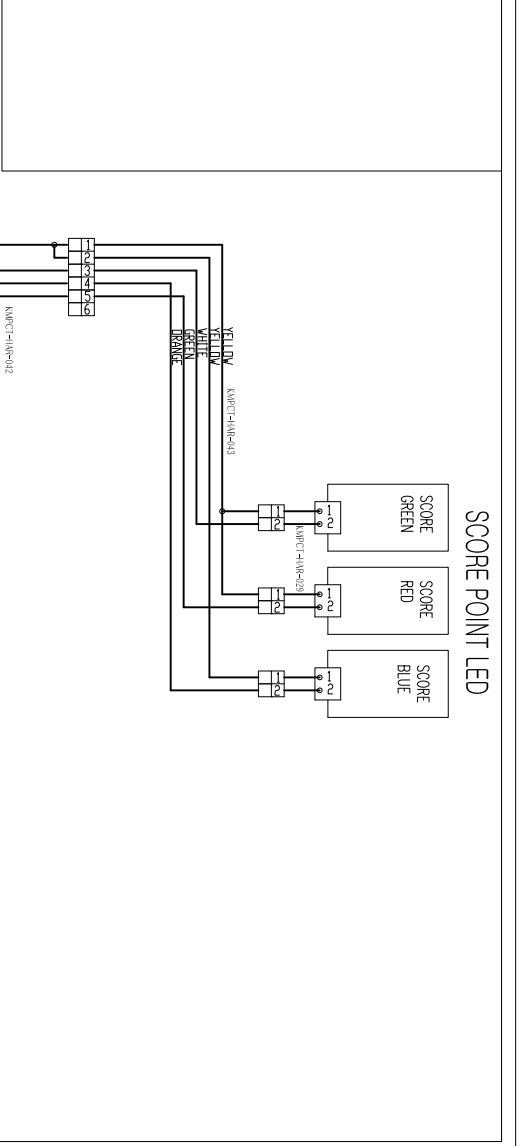
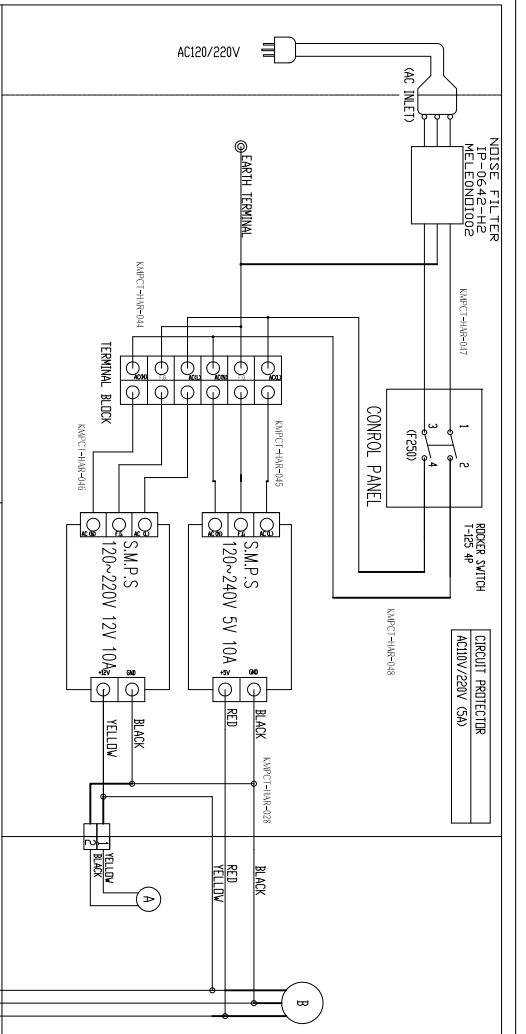

MZZZSPR004
MFD 4.5T 80W
80W

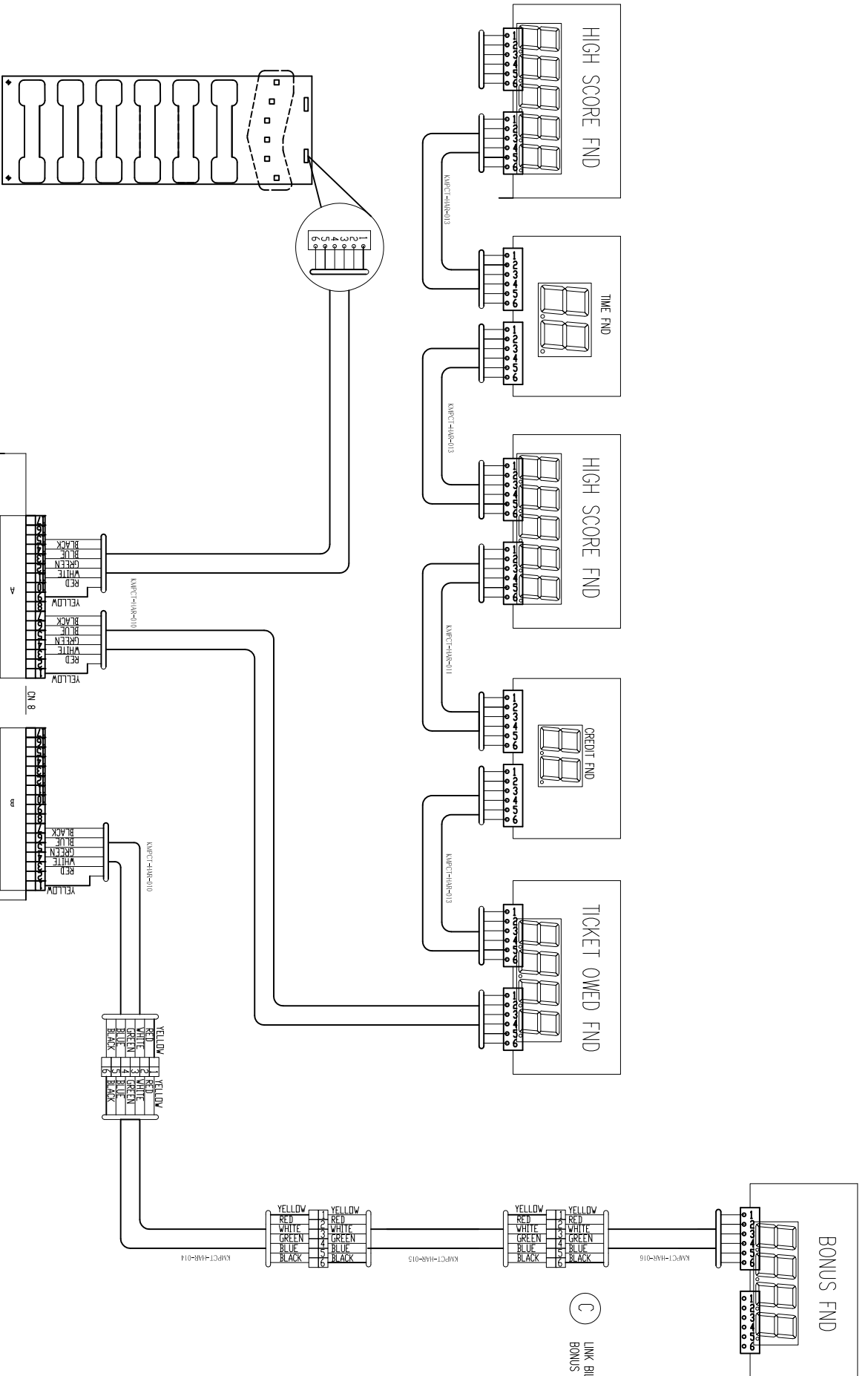

LINK BILLBOARD
BONUS FND

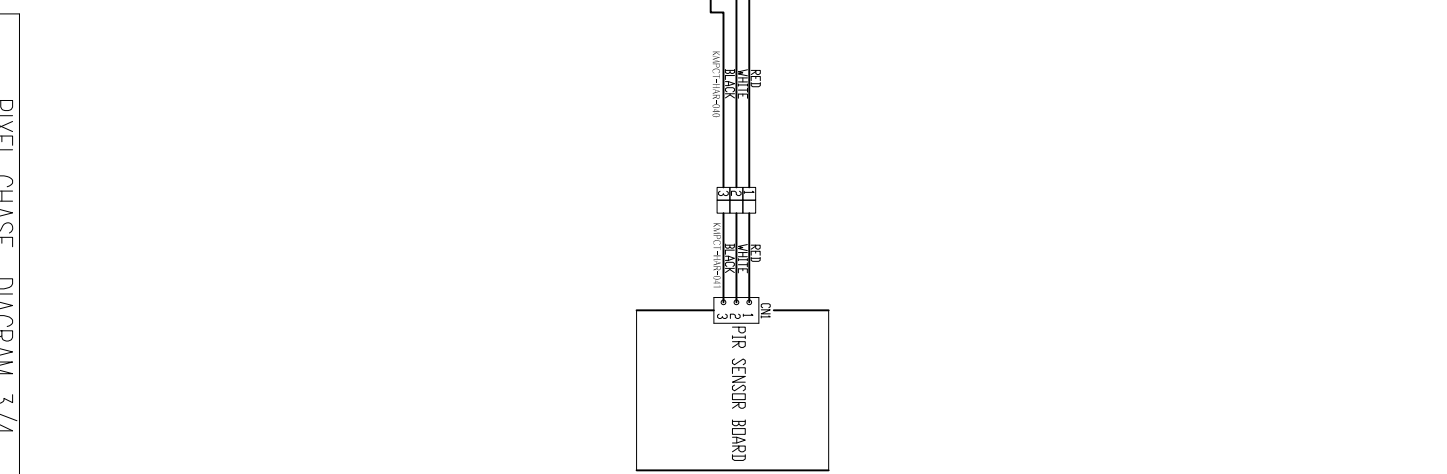
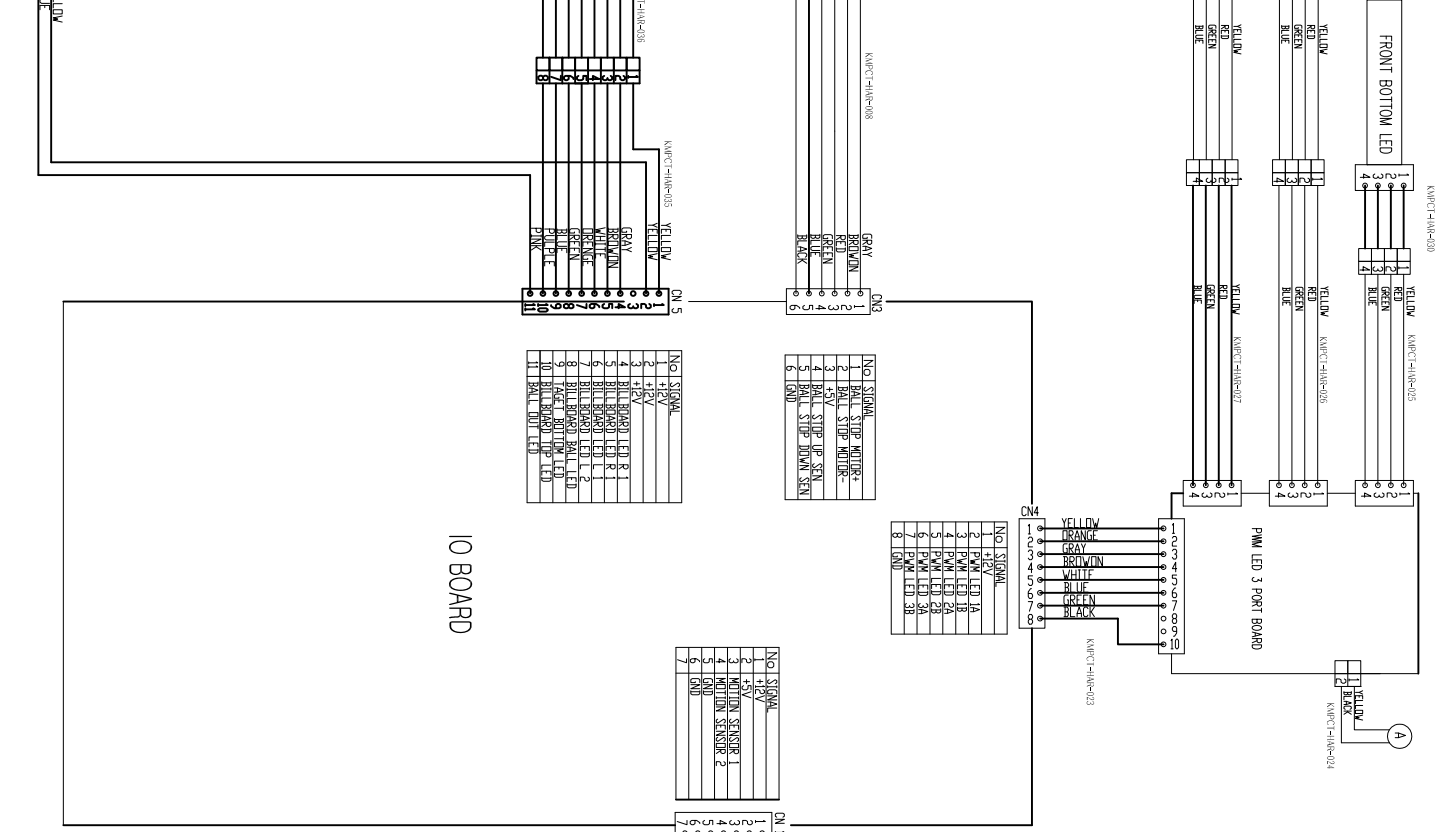
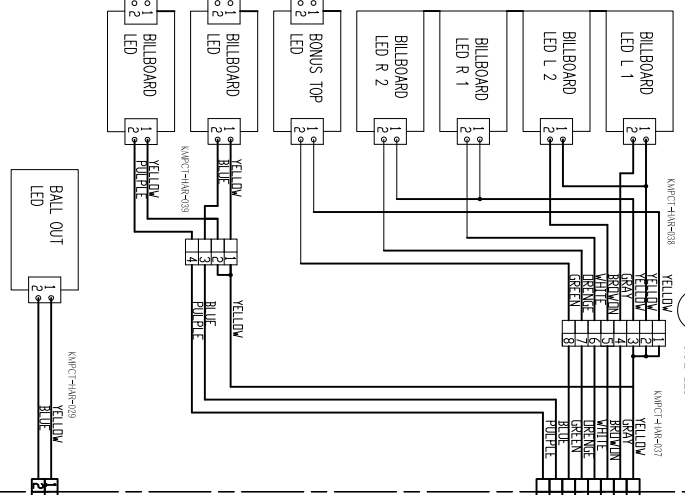
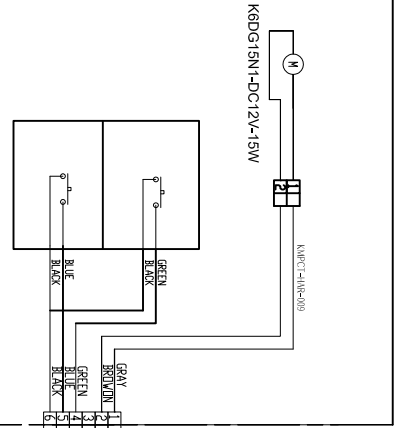
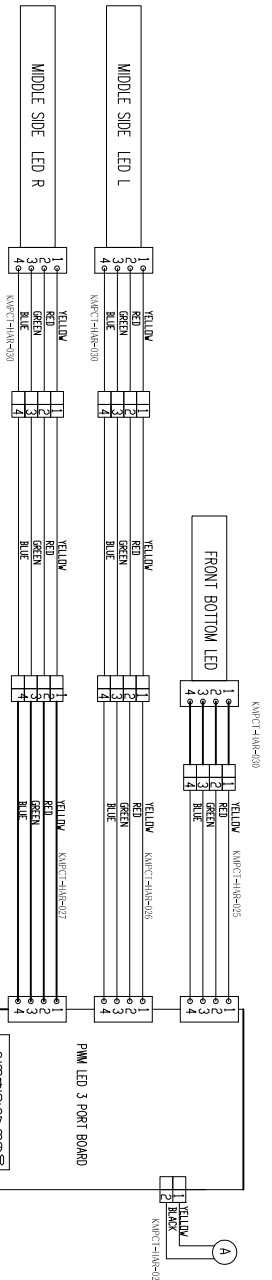

FRONT VIEW

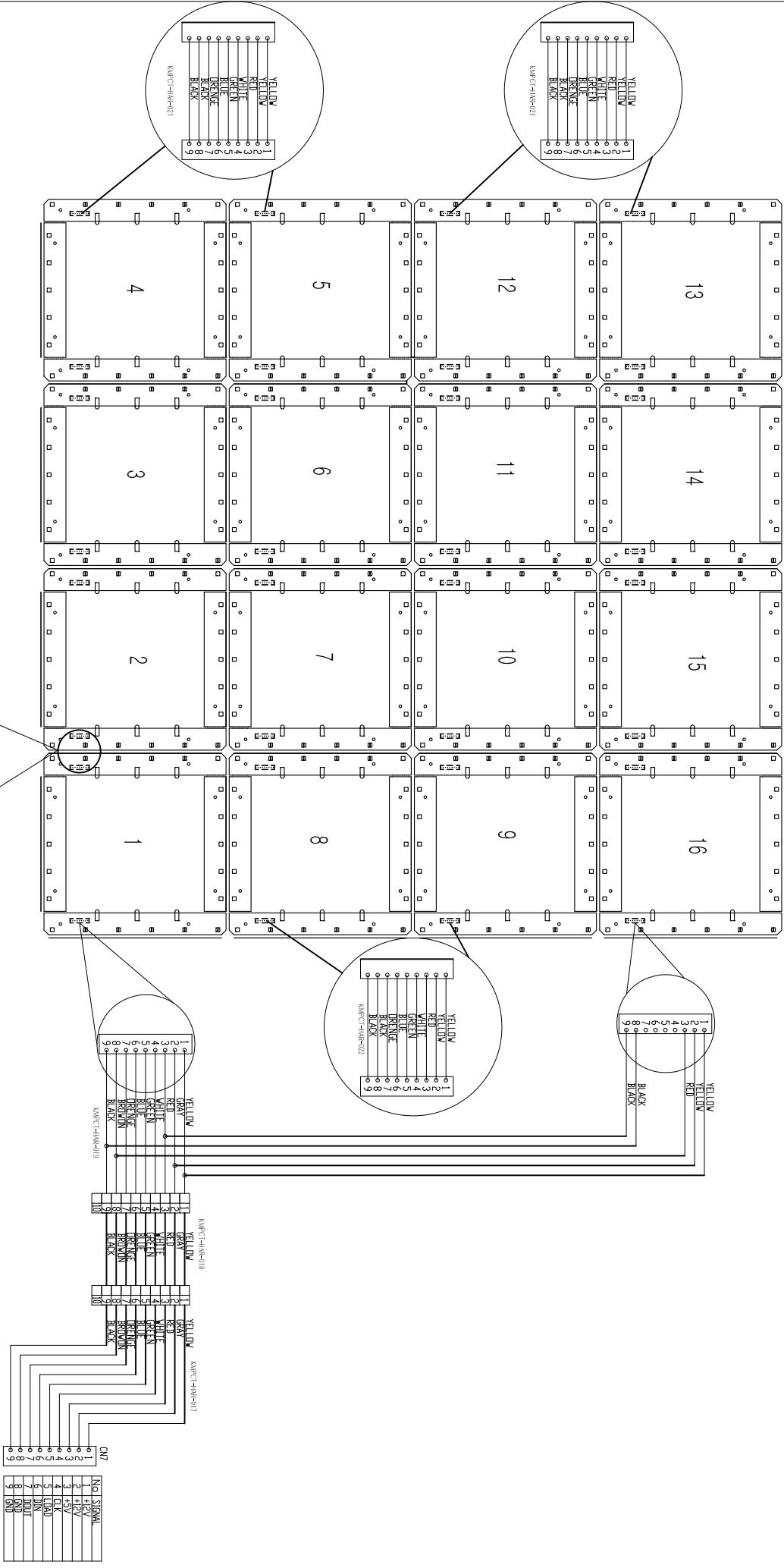

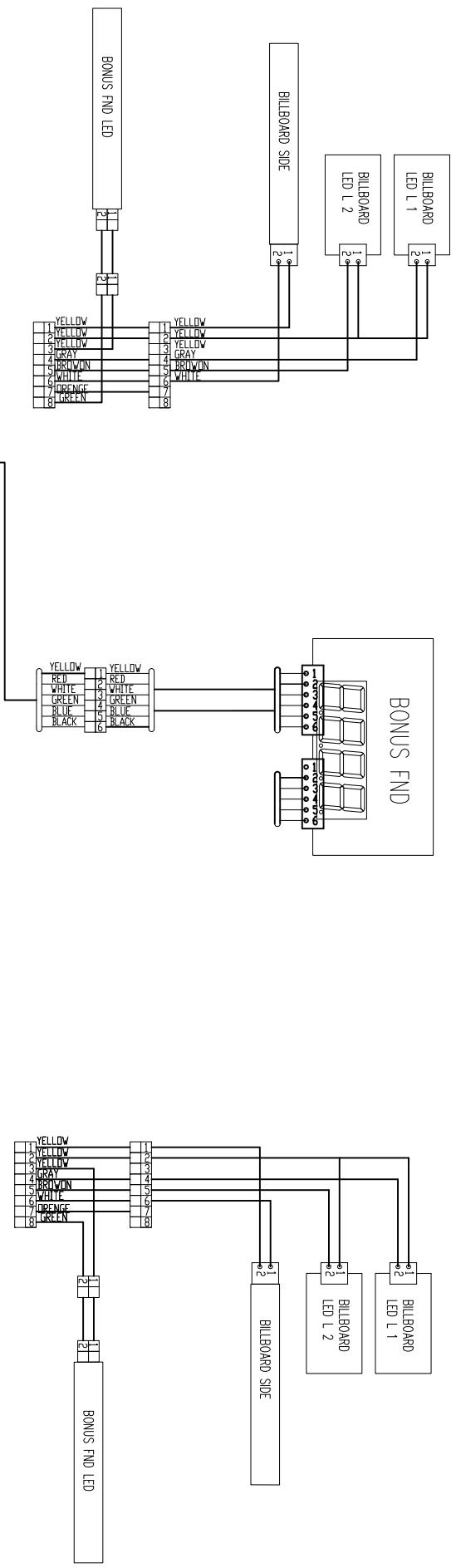

OPTION

PIXEL CHASE



2018. 12. 18

PIXEL CHASE

IMAGE		NAME	QUANTITY	METERIAL	CDDE NO.
1		BILLBOARD CENTER FRAME COVER ACRYL	1 EA	ACRYL Silk screen	MPIX0A&S009
2		BILLBOARD SIDE FRAME COVER ACRYL L	1 EA	ACRYL Silk screen	MPIX0A&S010
3		BILLBOARD SIDE FRAME COVER ACRYL R	1 EA	ACRYL Silk screen	MPIX0A&S011
4		BILLBOARD BACK LIGHT PC COVER ACRYL	1 EA	ACRYL Silk screen	MPIX0A&S008
5		BILLBOARD SIDE UPPER BALL STOP ACRYL L	1 EA	ACRYL Silk screen	MPIX0A&S007
6		BILLBOARD SIDE UPPER BALL STOP ACRYL R	1 EA	ACRYL Silk screen	MPIX0A&S006
7		MIDDLE SIDE ACRYL	2 EA	ACRYL Silk screen	MPIX0A&S005
8		FRONT CASE SCORE FND ACRYL	1 EA	ACRYL Silk screen	MPIX0A&S004
9		SCORE BOX BOTTOM LED ACRYL	1 EA	ACRYL Silk screen	MPIX0A&S003
10		FRONT TITLE ACRYL	1 EA	ACRYL Silk screen	MPIX0A&S002
11		FRONT DECO ACRYL	1 EA	ACRYL Silk screen	MPIX0A&S001
12		BILLBOARD SIDE FRAME SHEET	4 EA	SHEET Silk screen	MPIX0SHE001
13		BILLBOARD BOTTOM BALL STOP BRKT SHEET	1 EA	SHEET Silk screen	MPIX0SHE002



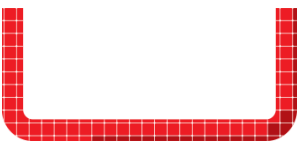

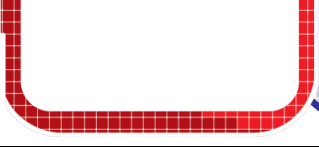



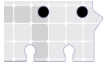

	IMAGE	NAME	QUANTITY	METERIAL	CDDE NO.
14		SIDE MID COVER SHEET UP L	1 EA	SHEET Silk screen	MPIXOSHE003
15		SIDE MID COVER SHEET UP R	1 EA	SHEET Silk screen	MPIXOSHE004
16		SIDE MID COVER SHEET LOW L	1 EA	SHEET Silk screen	MPIXOSHE005
17		SIDE MID COVER SHEET LOW R	1 EA	SHEET Silk screen	MPIXOSHE006
18		SIDE MID PANEL SHEET UP L	1 EA	SHEET Silk screen	MPIXOSHE007
19		SIDE MID PANEL SHEET UP R	1 EA	SHEET Silk screen	MPIXOSHE008
20		SIDE MID PANEL SHEET LOW L	1 EA	SHEET Silk screen	MPIXOSHE009
21		SIDE MID PANEL SHEET LOW R	1 EA	SHEET Silk screen	MPIXOSHE010
22		REAR CASE SIDE SHEET L	1 EA	SHEET Silk screen	MPIXOSHE011
23		REAR CASE SIDE SHEET R	1 EA	SHEET Silk screen	MPIXOSHE012
24		SIDE BRKT RR SHEET L	1 EA	SHEET Silk screen	MPIXOSHE013
25		SIDE BRKT RR SHEET R	1 EA	SHEET Silk screen	MPIXOSHE014

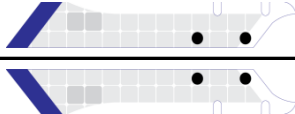





	IMAGE	NAME	QUANTITY	METERIAL	CDDE NO.
26		FRONT CASE SIDE SHEET L	1 EA	SHEET Silk screen	MP1XOSHE015
27		FRONT CASE SIDE SHEET R	1 EA	SHEET Silk screen	MP1XOSHE016
28		SIDE BRKT FW SHEET L	1 EA	SHEET Silk screen	MP1XOSHE017
29		SIDE BRKT FW SHEET R	1 EA	SHEET Silk screen	MP1XOSHE018
30		FRONT SHEET L	1 EA	SHEET Silk screen	MP1XOSHE019
31		FRONT SHEET R	1 EA	SHEET Silk screen	MP1XOSHE020
32		TICKET OWED SHEET	1 EA	SHEET Silk screen	MP1XOSHE021
33		INSERT COIN SHEET	1 EA	SHEET Silk screen	MP1XOSHE022
34		INSERT COIN DECO SHEET	2 EA	SHEET Silk screen	MP1XOSHE023
35		BALL OPERATION UPPER STOP PA ACRYL	2 EA	SHEET Silk screen	MP1XOSHE024
36		LIGHTING BLOCK INNER SHEET	32 EA	SHEET Silk screen	MP1XOSHE025
37		LIGHTING BLOCK SHEET	64 EA	SHEET Silk screen	MP1XOSHE026
38		SETUP CONTROL PANEL SHEET	1 EA	SHEET Silk screen	MP1XOSHE027
39		DANGER DO NOT STEP HERE SHEET	2 EA	SHEET Silk screen	MP1XOSHE028
40		DANGER NO STEP SHEET	1 EA	SHEET Silk screen	MP1XOSHE029
41		WARNING HIGH VOLTAGE SHEET	1 EA	SHEET Silk screen	MP1XOSHE030
42		WARNING SERVICE MAN SHEET	2 EA	SHEET Silk screen	MP1XOSHE031
43		CAUTION DAMAGE SHEET	1 EA	SHEET Silk screen	MP1XOSHE032
44		CAUTION FINGER SHEET	1 EA	SHEET Silk screen	MP1XOSHE033
45		SEGA LOGO SHEET LARGE	1 EA	SHEET Silk screen	MP1XOSHE034
46		RING WASHER SHEET	30 EA	FILM SHEET	MP1XOSHE035
47		SCORE PART LIGHT ACRYL SHEET 1000	1 EA	LIGHTING SHEET	MP1XOSHE036
48		SCORE PART LIGHT ACRYL SHEET 700	1 EA	LIGHTING SHEET	MP1XOSHE037
49		SCORE PART LIGHT ACRYL SHEET 500	1 EA	LIGHTING SHEET	MP1XOSHE038

	IMAGE	NAME	QUANTITY	METERIAL	CDDE NO.
50		CREDIT COVER ACRYL SHEET	1 EA	LIGHTING SHEET/ FND FILM	MPIXOSHE039
51		UK SCORE TICKET COVER ACRYL SHEET #5	1 EA	LIGHTING SHEET	MPIXOSHE040
52		USA SCORE TICKET COVER ACRYL SHEET #7	1 EA	LIGHTING SHEET	MPIXOSHE041
53		SCORE TICKET COVER ACRYL SHEET #8	1 EA	LIGHTING SHEET	MPIXOSHE042
54		SCORE TICKET COVER ACRYL SHEET #0 (option)	1 EA	LIGHTING SHEET	MPIXOSHE043
55		SCORE TICKET COVER ACRYL SHEET #1 (option)	1 EA	LIGHTING SHEET	MPIXOSHE044
56		SCORE TICKET COVER ACRYL SHEET #2 (option)	1 EA	LIGHTING SHEET	MPIXOSHE045
57		SCORE TICKET COVER ACRYL SHEET #3 (option)	1 EA	LIGHTING SHEET	MPIXOSHE046
58		SCORE TICKET COVER ACRYL SHEET #4 (option)	1 EA	LIGHTING SHEET	MPIXOSHE047
59		SCORE TICKET COVER ACRYL SHEET #6 (option)	1 EA	LIGHTING SHEET	MPIXOSHE048
60		SCORE TICKET COVER ACRYL SHEET #9 (option)	1 EA	LIGHTING SHEET	MPIXOSHE049
61		SCORE TICKET COVER ACRYL SHEET #10(option)	1 EA	LIGHTING SHEET	MPIXOSHE052
62		DANGER NO STEP SMALL SHEET	1 EA	SHEET Silk screen	MPIXOSHE054

SPARES AND SERVICE CONTACT INFORMATION

- SEGA TOTAL SOLUTIONS -

42 Barwell Business Park
Leatherhead Road,
Chessington,
Surrey,
KT9 2NY
United Kingdom

Parts/Customer Service : +44 (0) 208 391 8060

Technical Support : +44 (0) 208 391 8072



- PLAY IT AMUSEMENTS -

870 Lively Blvd
Wood Dale,
IL,
60191
United States of America

Parts/Customer Service : +00 (1) 224 265 4287

Technical Support : +00 (1) 224 265 4283

