



Nitro Trucks

Setup and Operation Service Manual

Revision Nitro-1.3-2.26



Nitro Trucks Game Software Copyright 2020 Play Mechanix™ Inc.

This software is based in part on the work of the Independent JPEG Group.

This product includes software developed by the OpenSSL Project for use in the OpenSSL Toolkit. (<http://www.openssl.org/>)

This product includes cryptographic software written by Eric Young (ey@cryptsoft.com)

This product includes audio software developed by FMOD Studio. (<https://www.fmod.com/>)

Table of Contents

Safety.....	3
Product Specifications.....	5
Fuse Replacement Guide.....	6
Setup.....	6
Game Software Setup.....	9
Disassembly Instructions.....	10
Game Networking.....	11
Maintenance.....	12
Troubleshooting.....	13
Online Troubleshooting.....	16
Parts.....	17
System Diagrams.....	28
Contact Information.....	32





Safety

OPERATION

Before operating game, read this manual. Failure to properly install and operate this game could result in malfunction or accident. Operate the game in accordance with the manual.

TRANSPORTING

Cabinet is very heavy and contains fragile components. Use appropriate care when moving or transporting cabinet. Avoid rough handling.

HANDLING COMPONENTS

Many components are extremely sensitive to handling, environmental and Electrostatic Discharge (ESD) events—especially the computer. Do not handle it roughly. Before servicing, call your distributor and inquire about the PC warranty. Use proper ESD procedures when servicing. Protect components from harmful environmental conditions, such as extreme temperatures, excessive moisture or other damaging effects.

DISCONNECT POWER

Always turn off power and unplug the units before servicing or making adjustments, unless otherwise instructed. Installing or repairing components while power is on can damage the components and void the warranty.

GROUNDING

Avoid electrical shock. Do not plug in AC power until you have inspected and properly grounded the unit. Only plug into a grounded, three-wire outlet. Do not use a “cheater” plug or cut off the ground pin on the line cord.

ELECTRICAL SHOCKS

There is no isolation transformer in the cabinet. Disconnect AC power before servicing. However, be aware that lethal voltages can remain in the electronic components even when AC power is disconnected. Use extreme caution when servicing. Verify that there is a working ground connection. If the unit sustains water damage, cease using it immediately and unplug AC power.

MONITOR

The monitor contains no user serviceable parts. Do not attempt to service the monitor.

POWER CORD

If the power cord is damaged or lost, replace it with an identical cord as supplied by the manufacturer or an authorized service agent.

SURGE SUPPRESSOR

It is recommended that you plug your game’s power cord into a surge suppressor to help protect from power surges that may damage sensitive electronic components.

WATER AND OTHER LIQUID

Do not install game near sprinkler or other water jet sources. Do not use water jet to clean game. Keep minimum clearance behind game and wall for proper ventilation but also prevent access of liquid from spills and sprays from entering ventilation holes.

Nitro Trucks Service Manual

CONNECTORS

Ensure all connectors mate properly. If connectors do not slip in easily, do not force them. Connectors are often keyed and only connect one way. Check for correct orientation.

COMPUTER

The computer contains sensitive components, including a hard drive. Do not handle it roughly. Call your distributor before servicing its internal components. Ask about warranty information as it relates to the PC.

Do not turn the PC power switch on or off. It should remain permanently in the ON position.

Cycle AC power on or off with the cabinet power switch.

A dongle has been inserted into one of the USB ports. This is required for game play.

Do not remove the dongle except for troubleshooting purposes.

TEMPERED GLASS WARNING

When handling the LCD display glass cover take special care and set the glass down softly on a flat surface free of debris. The edge of the glass is sensitive to hard impact. Shattered glass from the monitor can travel long distances and cause bodily injury. Use proper procedures when handling broken materials.

HAZARD TO EPILEPTICS

A small portion of the population has an epileptic condition that may cause seizures. Affected persons experience seizure while watching some television pictures or playing certain video games. People who have not had seizures may still have an undetected epileptic condition. If anyone in your family has experienced epilepsy symptoms (seizures or loss of awareness), consult your physical before using video games. While children play video games, a parent should observe. Be alert to the following symptoms: dizziness, altered vision, eye or muscle twitching, involuntary movements, loss of awareness, disorientation or convulsions. If you or your child experiences these symptoms, discontinue use immediately and consult your physician.

MANUAL

Keep this manual available and ready for use. If the game fails to function properly, turn off the machine and unplug the AC line cord. Contact your local distributor. You may not reproduce this document or any of its contents without written authorization from Raw Thrills™, Inc. or PlayMechanix™ Inc.

SPECIFICATIONS

For reasons such as performance, this product's specifications may change without notice. Federal patent, copyright and other intellectual property laws protect the content, devices and design of the game and its equipment.



Product Specifications

Electrical Power

Unites States, International and Japan
Operating AC Current: 5/2.5 Amps
Voltage: 115/230 ~ VAC 50/60Hz

Temperature

50° to 104° Fahrenheit (10° to 40° Celsius)

Humidity

Must not exceed 95% relative humidity

Carton Dimensions

85" L x 47" W x 85-1/2" H

Cabinet Dimensions

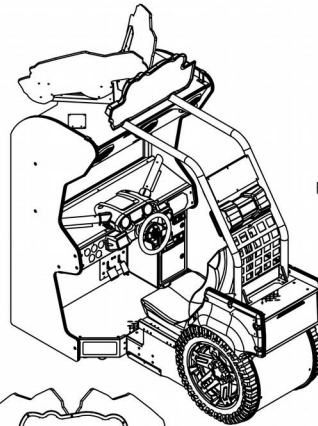
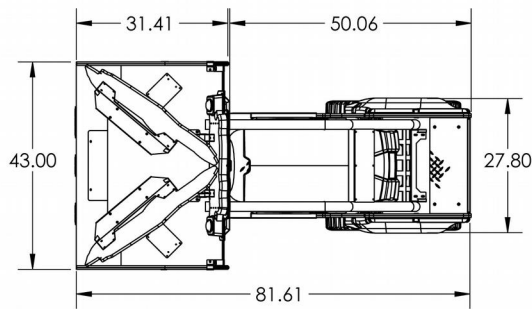

TRANSPORT OF NITRO TRUCKS
ROLLBAR ASSEMBLY, MARQUEE AND FOAMBOARD PANELS MUST BE REMOVED FROM SEAT AND MAIN CABINETS WHEN GAME IS TO BE MOVED

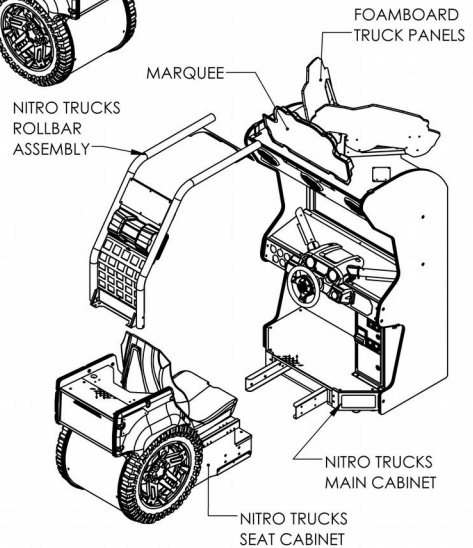
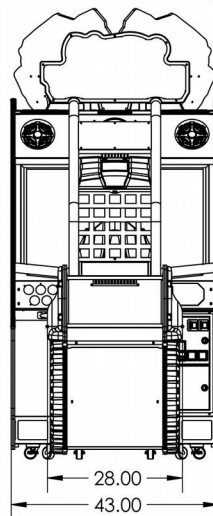
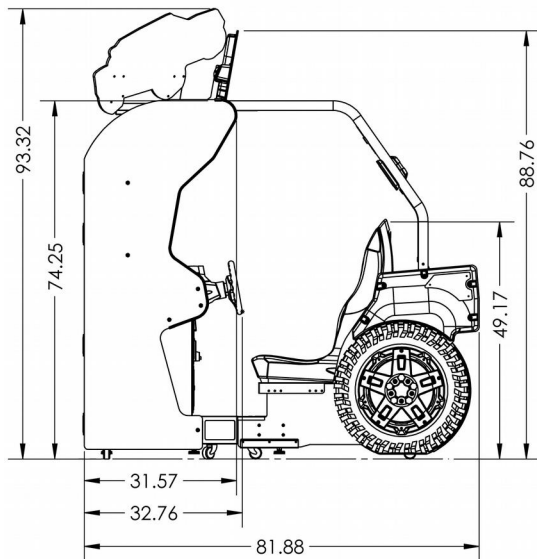

Cabinet Weight

846 lbs (383.74 kg)

Fuse Replacement Guide

NOTE: FOR CONTINUED PROTECTION AGAINST FIRE AND ELECTRICAL DAMAGE,
USE ONLY SPECIFIED FUSE TYPE AND VALUE.

(7) 12V fuses:

Please see unit for specified fuse labeling. Abbreviations:

5A 250V	5A, 250VAC Fast Acting 3AG Fuse	Littlefuse 0312005.MXP (or equivalent)
---------	---------------------------------	--

Setup

Unpack Cartons

1. Unpack all components
 - Assembled Cabinet
 - Marquee Topper
 - Left & Right foam board Truck Topper
 - Additional hardware (bolts, washers, lock washers)
2. Find the keys (taped to the main cabinet fronts) for the cabinet coin box.
3. Unlock the cabinet coin box to access diagnostic switch panel.

Install Marquee

1. Position Marquee on top of Main Cabinet.

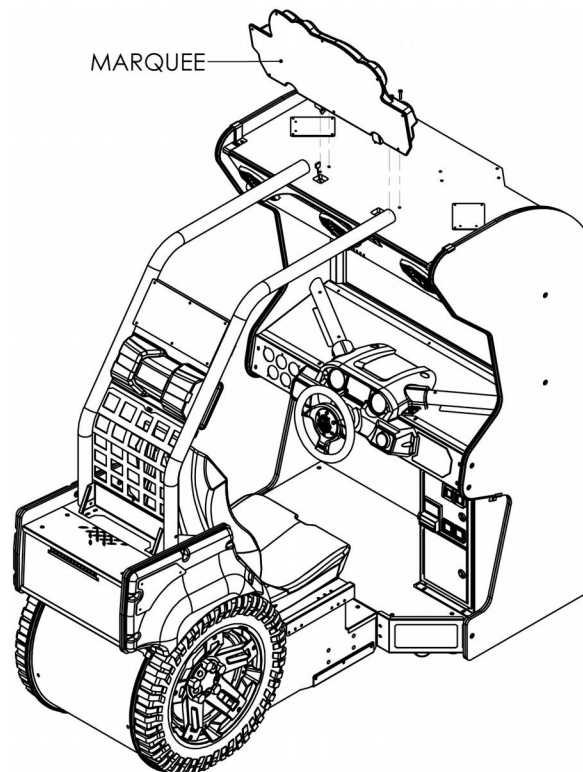

2. Connect Marquee cable harness to Main Cabinet.
3. Route excess cable into holes on top of the cabinet, being careful not to pinch any cables.
4. Secure Marquee to Main Cabinet, using 4 bolts, 4 washers, and 4 lock washers.

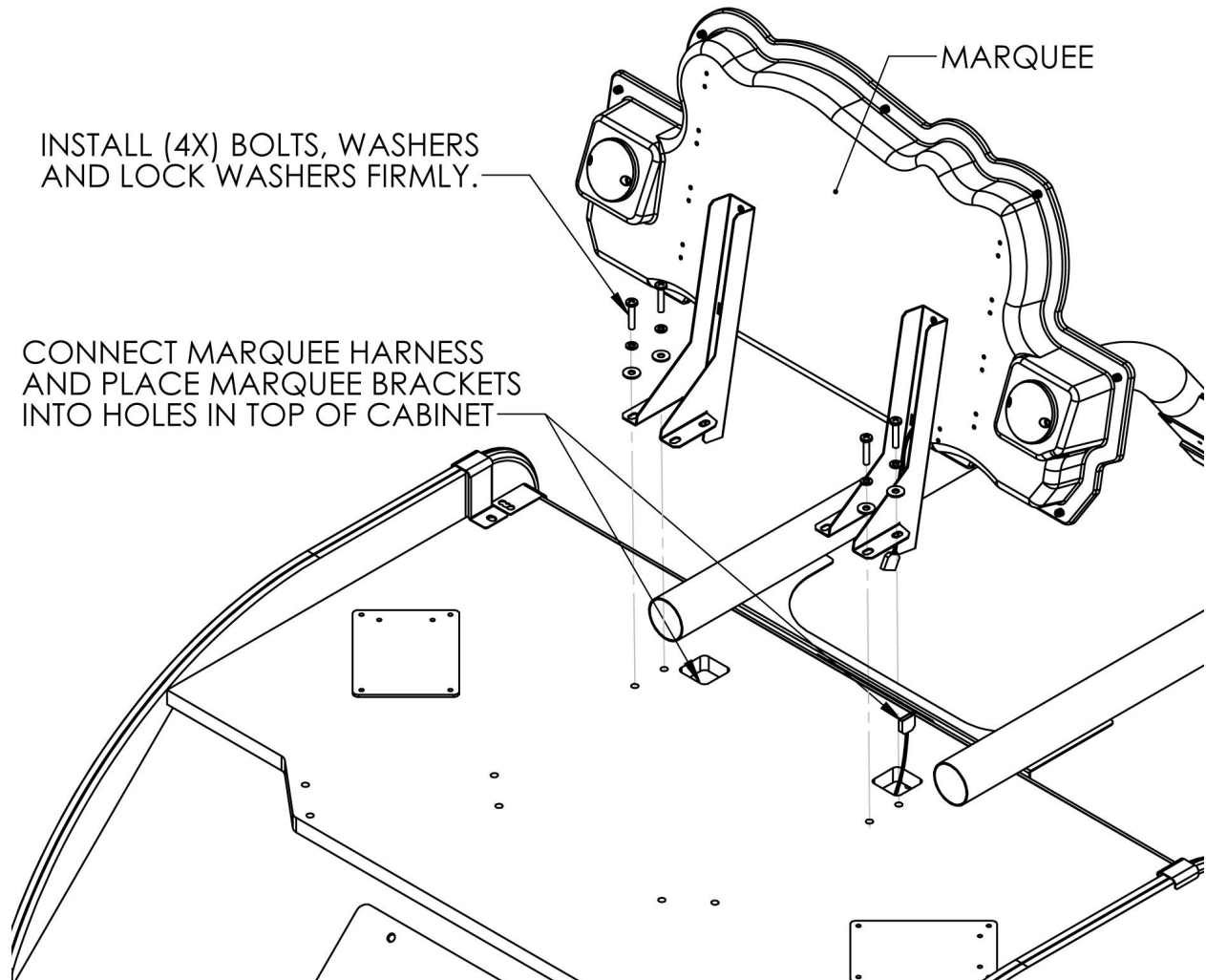

Install Truck Toppers

1. Position Truck Toppers on top of Main Cabinet.
2. Secure Truck Toppers to Main Cabinet, using 4 bolts, 4 washers, and 4 lock washers for each.

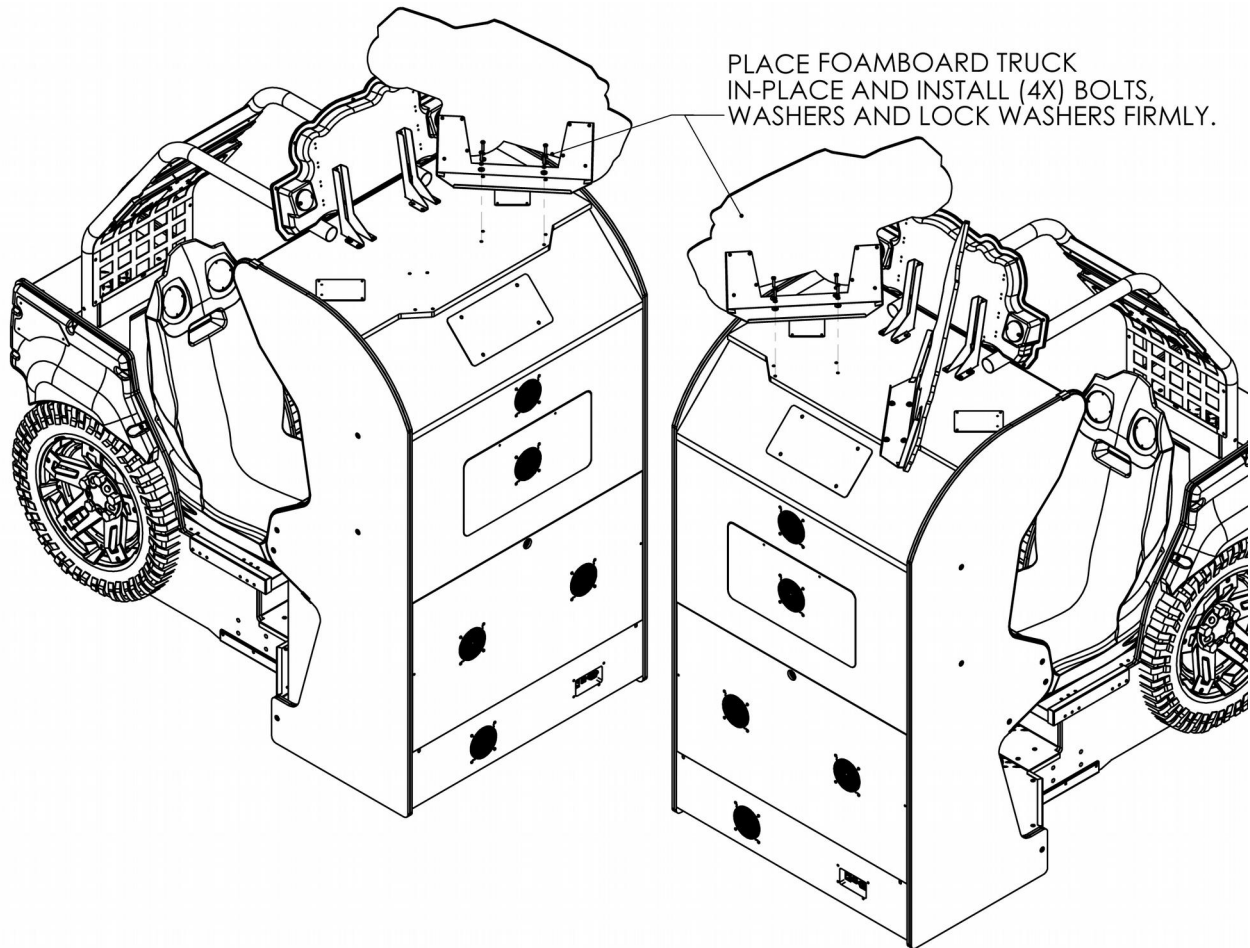

Verify Cabinet Functionality

1. Verify the voltage in the nearest AC outlet.
2. Verify the AC outlet ground connection is present and working.
3. Verify that the specified operating current will not overload the supply circuits.
4. Plug the line cord into AC outlets.
5. Turn the main cabinet power switch to ON.
6. Verify that the cooling fans on the cabinet are working.
If not, turn off AC power and disconnect line cord. Contact Betson service
7. Check that no component is excessively hot or emitting foul odors.
If so, turn off AC power and disconnect line cord. Contact Betson service.
8. Once software loads, you will be asked to setup the cabinet software.



Game Software Setup

Initial Setup

When first turned on, follow the onscreen prompts to complete initial game setup.

Calibration

Follow the onscreen prompts to calibration user input devices.

Cabinet Number

Each cabinet at your location must be set with a unique cabinet number, in order to link together. The unit set as #1 will become the primary. Other local cabinets will periodically synchronize various settings to the primary unit. The attract mode of local units will also try to synchronize to the primary unit.

Connectivity Wizard

Configure your game for either online or local connectivity.

Operator Registration

1. If connecting online, login to an existing operator account or create a new account.
2. To register as a new operator, follow the onscreen prompts.

Cabinet Registration

If connecting online, select or setup a location for the cabinet.

Verify Input and Output Functionality

1. Enter the Diagnostic menu
2. Enter the INPUT TESTS menu and verify all switches and inputs function.
3. Enter the VIDEO TESTS menu and verify that video is acceptable.
4. Enter the COIN METER TEST and verify the operation of the coin meter.
5. Enter the LAMP TESTS menu and verify that the lamps of the buttons work correctly.
6. Enter the SOUND TEST menu and verify the audio works and is not distorted.
7. Enter the WATCHDOG TEST menu, which re-boots the game.
8. Upon a successful re-boot, you are ready to make adjustments to pricing, volume and other functions found in the Diagnostic menu.

Verify Cabinet Connectivity

1. If connecting online, enter the ONLINE menu.
2. Select CONNECTION DETAILS AND TEST and run a test connection.
3. If any of the tests result in FAILURE, consult troubleshooting section or your network admin.
4. Select MATCHMAKER CONNECTION TEST and run a test connection
5. If any of these tests result in FAILURE, you may not be able to host or join online matches.
Consult your network admin to make needed changes to the location's network architecture.

Disassembly Instructions

1. Remove truck toppers and marquee. See assembly instructions above.
2. Remove four bolts and washers securing rollbar assembly to main cabinet.
3. Remove four bolts and washers securing rollbar assembly to seat cabinet.
4. Disconnect cable connector from rollbar assembly to seat cabinet.
5. Remove rollbar assembly.
6. Remove four bolts and washers securing seat cabinet to main cabinet, from left and right side of seat cabinet.
7. Slowly separate seat cabinet and main cabinet. Be careful of cable connections.
8. Disconnect cable connectors from seat cabinet to main cabinet.

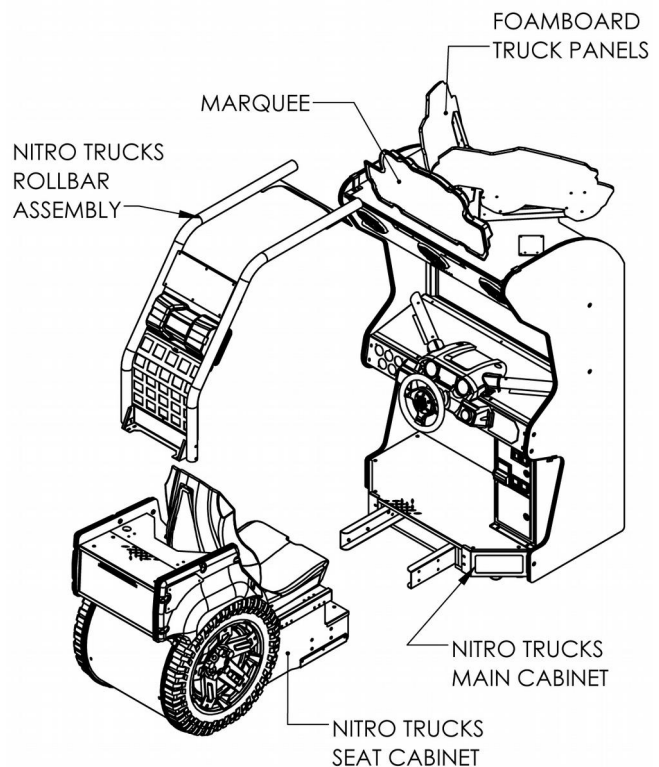



Game Networking

Networking Considerations

Take care to protect exposed game wiring from general foot traffic around the game. Use a conduit or wire way to protect cables, if needed. Network cables are not marked or coded. Mark the linking cables for your games, if other such cables in the area could cause confusion. Avoid routing cables near sources of heat, moisture, or electrical energy such as neon lights, compressor motors, etc.

Local Network Setup – 2 games

1. Turn off both game cabinets.
2. Remove the cross over network cable from the parts bag inside the cash box.
3. Connect each end of the cable to the Ethernet port of each game's PC.
4. Route the cable through the notch on the back of each cabinet.
5. Turn on both game cabinets
6. Enter Diagnostic Mode for each game
7. Select *Adjustments*
8. Select *Game Options*
9. Adjust *Cabinet Link Number* to give each game a unique number
10. In the *Online* menu, select *Connection Wizard*
11. When prompted, select *Local* and wait for the process to complete.

Local Network Setup – 3 to 8 games

1. Acquire a network hub with enough ports and the correct number of cables to support the desired number of games. Cables and hub are not supplied with the games.
2. Turn off all game cabinets
3. Connect an Ethernet cable to the Ethernet port on each game's PC
4. Connect each game's Ethernet cable to the network hub.
Consult network hub manual for any additional considerations specific to the hub.
5. Turn on all game cabinets
6. Enter Diagnostic Mode for each game
7. Select *Adjustments*
8. Select *Game Options*
9. Adjust *Cabinet Link Number* to give each game a unique number
10. In the *Online* menu, select *Connection Wizard*
11. When prompted, select *Local* and wait for the process to finish.

Online Network Setup

1. Set up DSL or cable modem service through an ISP for the location.
2. If connecting multiple games for online play, acquire a network hub with enough ports and the correct number of Ethernet cables to support the desired number of games. Cables and hub are not supplied with the games.

Nitro Trucks Service Manual

3. Turn off all game cabinets
4. Connect an Ethernet cable to the Ethernet port on each game's PC
5. Connect each game's Ethernet cable to the network hub.
Consult network hub manual for any additional considerations specific to the hub.
6. Connect the network hub to an external internet source.
7. Turn on all game cabinets
8. Enter Diagnostic Mode for each game
9. Select *Adjustments*
10. Select *Game Options*
11. Adjust *Cabinet Link Number* to give each game a unique number
12. In the *Online* menu, select *Connection Wizard*
13. When prompted, select *Online*.
14. Select either a dynamic or static IP.
15. Wait for configuration process to finish.

Maintenance

Hard Drive Recovery

Symptoms requiring hard drive recovery include:

- File Test reports bad or missing files
- Game fails to finish loading during startup
- After resetting the AC power, an error is reported
- Erratic Game or Attract Mode
- A screen indicating Data Files Corrupted

COMPUTER

The computer contains sensitive components, including a hard drive. Do not handle roughly. Call your distributor before servicing its internal components.

Do **not** use the PC on/off switch. Turn AC power on or off with the main cabinet power switches.

Flash Drive Restore

1. Turn cabinet AC power switch to OFF.
2. Connect Install #1 flash drive to an open USB port. ***This drive is unique to each game unit.***
3. Turn cabinet AC power switch to ON. Drive imaging should start automatically.
4. Initial software loading may take several minutes. Check progress periodically.
Do not interrupt power or reset the game during recovery.
5. When software has finished loading, turn cabinet power switch to OFF.
6. Remove Install #1 flash drive. Connect black Install dongle. Turn cabinet power switches to ON.
7. When prompted, connect #2 flash drive. This drive is not unique and can be shared between Nitro Trucks game units. Software install should start automatically.
8. Check progress periodically. ***Do not interrupt power or reset the game during recovery.***
9. When software has finished loading, turn cabinet power switches to OFF.
10. Remove both install #2 flash drive and black install dongle, before turning cabinet power ON.



Troubleshooting

Warning: Review safety chapter before making any adjustments to game.

General Troubleshooting

Problem	Possible Cause	Solution
Game will not power up	Game not plugged in.	Plug game into outlet.
	Game not turned on.	Turn on main power switch.
	Game fuse is blown.	Check and replace fuse.
	No power to receptacle.	Test outlet and plug game into powered outlet.
	PC not turned on.	Turn PC power switch on. Ensure IEC cable tightly plugged in. Trace cable back to source to ensure continuity.
	PC BIOS set incorrectly.	See BIOS Settings chapter.

NO VIDEO message	Video cables not plugged in properly	Reattach and/or tighten video cable to monitor. Reattach and/or tighten video cable to PC.
	Faulty video cable	Replace video cable
	PC not turned on.	Turn PC power switch on.

No sound	Bad Connection	Check connection to speakers. Check USB connection between PC and audio amplifier.
----------	----------------	---

Game does not load	Hard drive failure	Recover hard drive. See procedure on pg 12.
Hard drive test reports "bad" or "missing" files.		
Game fails to finish loading.		
After resetting, game still reports an error.		
Game suggests inserting a boot DVD.		
Erratic game mode or attract mode.		
<p style="text-align: center;">WARNING! Data Files Corrupted. (Game Operation May Become Unstable.) Use "Test" Switch to Enter Test Mode and Run "File Test." Press Start To Continue.</p>		

Game resets	Bad file.	Run File Test. Restore hard drive.
-------------	-----------	------------------------------------

Nitro Trucks Service Manual

Problem	Possible Cause	Solution
Controls are not responsive	Not calibrated	Check input tests and recalibrate if needed.
Coin meter does not click during Test	No pulse to meter	Check all wiring from meter to I/O board
	Faulty meter	Replace coin meter
Exits Test Mode every 3 seconds	Test button stuck in ON position	Slide or toggle button off after Test Menu appears
<i>Dongle Not Present</i>	Dongle missing or disconnected	Find dongle usb connection and reseal in USB port
	Faulty USB port	Connect dongle to another USB port
<i>Connect I/O Board or I/O Board Missing</i>	USB cable disconnected	Check USB connection from PC to I/O board Try connecting to a different USB port
	Blown fuse	Verify 12V fuses are not blown
	No power to RIO board	Check for proper voltage (+5V, +12V) at RIO P1 connector
	Bad RIO Board	Replace RIO board with known functional board

Matchmaker Troubleshooting

Matchmaker Ping fails	Game is not connected to the internet	Check Connection Details and Test for an IP and successful pings
NAT and Universal Plug n Play fail	Router configuration doesn't support network play	Contact IT administrator and/or consult router documentation.



Connection to CoinUp® Troubleshooting

General Connection Troubleshooting

Problem	Possible Cause	Solution
Connection Details and Test has IP address but Test Connection reports Database Ping failure or File Server Ping failure.	Firewall is blocking communication with server.	Read firewall documentation. Ensure configuration allows ICMP Echo. If router has built-in firewall, check router configuration. Enable communication on ports 80, 443, 7786, and 7787.
	Database or File Server is down	Wait 30 minutes and revisit Test Connection screen. If still reporting failure, call CoinUp® service.

Ethernet Connection Troubleshooting

Problem	Possible Cause	Solution
Games are not connecting locally to each other	Disconnected cable(s) Faulty Ethernet cable(s) Faulty router/hub	Check that all cables are securely connected. Try replacing cables. Verify router/hub is powered. Try replacing the router/hub.
Game cannot connect to CoinUp® server. No IP address appears under Connection Details and Test	No broadband internet service	Contact a local ISP to setup either cable modem or DSL service.
	Wrong router configuration	Configure router for DHCP (Dynamic Host Configuration Protocol).
	Disconnected Ethernet cable	Check that Ethernet cables are tightly connected at both ends. An audible click confirms tightness. Reboot game. In Diagnostic mode, select Online, then Test Connection. Confirm that IP address appears. The phrase eth0 must follow IP address.
	Faulty Ethernet cable	Test cable by connecting it from another PC into router or wall jack. Replace cable if faulty.
	Faulty Ethernet wall jack.	Plug Ethernet cable into a different jack.
	Broadband service is down.	Contact ISP.
	Faulty router	Plug Ethernet cable into different jacks in router. Plug Ethernet cable directly into DSL or cable modem instead of router. Replace router if faulty.
	Faulty network card	Call CoinUp® service

Online Troubleshooting

Problem	Possible Cause	Solution
Game cannot connect to CoinUp® server. No IP address appears under Test Connections menu	No broadband internet service	Contact a local ISP to setup either cable modem or DSL service.
	Wrong router configuration	Configure router for DHCP (Dynamic Host Configuration Protocol).
	Disconnected Ethernet cable	Check that Ethernet cables are tightly connected at both ends. An audible click confirms tightness. Reboot game. In Diagnostic mode, select Online, then Test Connection. Confirm that IP address appears. The phrase eth0 must follow IP address.
	Faulty Ethernet cable	Test cable by connecting it from another PC into router or wall jack. Replace cable if faulty.
	Faulty Ethernet wall jack.	Plug Ethernet cable into a different jack.
	Broadband service is down.	Contact ISP.
	Faulty router	Plug Ethernet cable into different jacks in router. Plug Ethernet cable directly into DSL or cable modem instead of router. Replace router if faulty.
	Faulty network card	Call CoinUp® service

Problem	Possible Cause	Solution
Game has IP address and screen says <i>Server Ping Success</i> but Test Connection screen reports Database Ping failure or File Server Ping failure.	Firewall is blocking communication with server.	Read firewall documentation. Ensure configuration allows ICMP Echo. If router has built-in firewall, check router configuration. Enable communication on ports 80, 443, 7786, and 7787.
	Database or File Server is down	Wait 30 minutes and revisit Test Connection screen. If still reporting failure, call CoinUp® service.

Parts

Main Cabinet Assembly

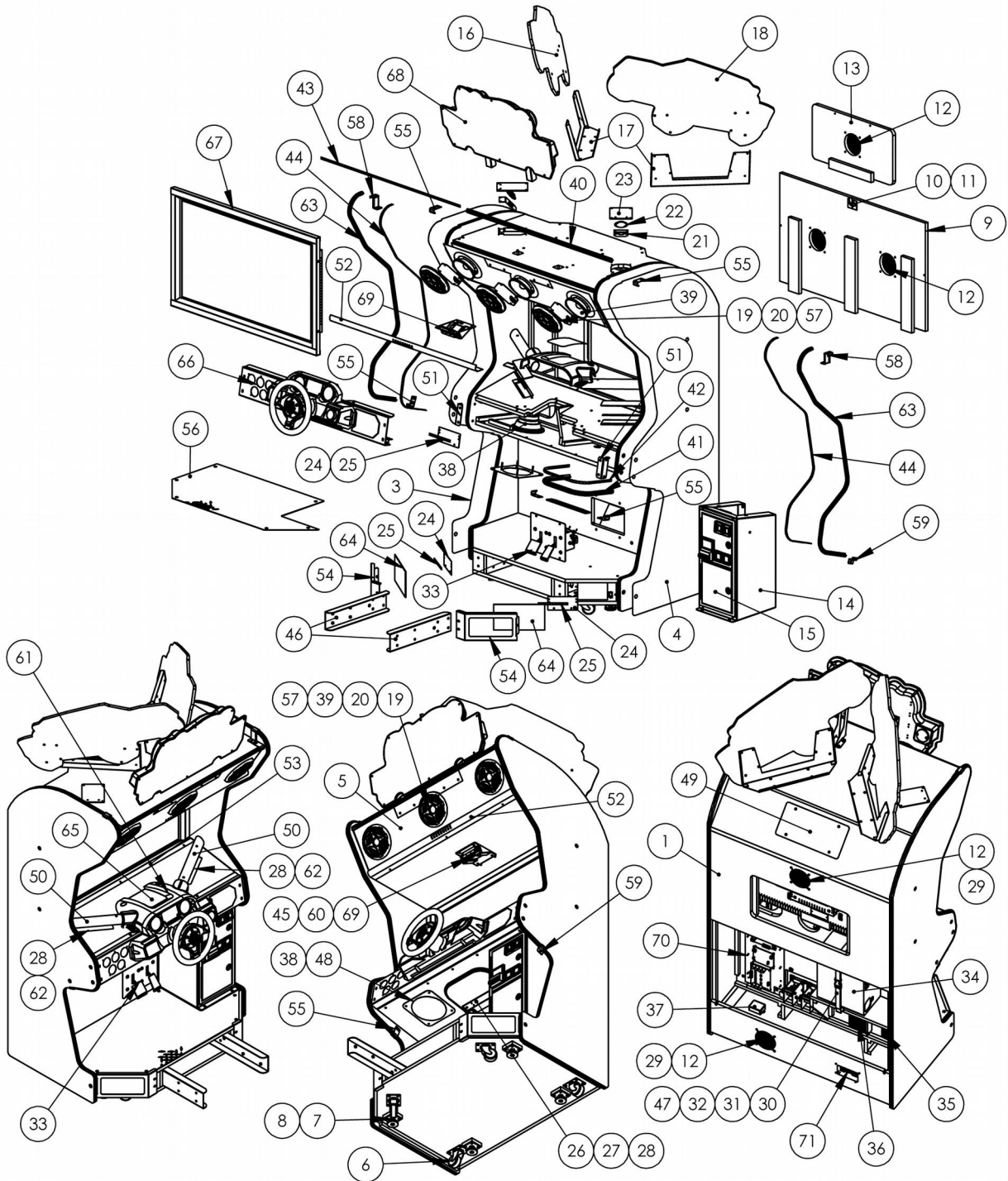

Nitro Trucks Service Manual

Main Cabinet Assembly Part Numbers

Item	Part No.	Description	QTY
1	601-00877-01	ASSY-MAINCAB-NITRO-TRUCKS	1
2	606-01753-01	DECAL-LCD-SHELF-NT	1
3	606-01751-01	DECAL-LEFT-SIDE-MAINCAB-NT	1
4	606-01751-01	DECAL-RIGHT-SIDE-MAINCAB-NT	1
5	606-01754-01	DECAL-SPEAKER-PANEL-NT	1
6	CASTER 2"5	STD-2.50-CASTER	4
7	Leg leveler plate	2.50 x 2.50 x 1/2-13 CTR – LEVELER PLATE	4
8	Leg Leveler 1_2 x 3 inch	1/2-13 x 4" length	4
9	601-00879-01	MAINCAB-REAR-DOOR-NITRO-TRUCKS	1
10	Lock 7/8" w/ 1.25 Cam	LOCK STANDARD	1
11	LOCK RETAINER N202-130	LOCK RETAINER N202-130	1
12	800-00001-00	120mm Wire Fan Guard	5
13	601-00880-01	DOOR-LCD-NITRO-TRUCKS	1
14	600-02552-01	VAULT-COIN-DOOR-NT	1
15	800-00005-01	MID-WIDTH COINDOOR – BBHD	1
16	606-01771-01	LEFT-PRINTED-ULTRABOARD-PANEL-NT	1
17	600-02556-01	BRACKET-FOAMBOARD-NT	2
18	606-01772-01	RIGHT-PRINTED-ULTRABOARD-PANEL-NT	1
19	603-00890-01	SB3 Speaker Cover-IM (Plated)	3
20	500-00245-55	55CM-RGB-CLEAR-ENCASED-LED-STRIP	3
21	600-02272-01	BRACKET-PUCK-LIGHT-PROJECT-RING	2
22	500-00205-01	White LED Superpuck PCB-36LEDS	2
23	603-00942-01	PETG-PUCK-LIGHT-HALO-55	2
24	600-02618-01	PLATE-LEDS-NT	3
25	15CM LED STRIP (WHITE)	15cm LED Strip (WHITE)	3
26	603-00989-01	PETG-UNDER-CABINET-NT	1
27	600-02590-01	CHANNEL-LED-NT	1
28	20CM LED STRIP (RGB)	20cm Flexible LED Strip (RGB)	3
29	820-00001-00	FAN 120VAC 19/15W	2
30	87425K76 (56 length)-for-HP	Nylon Strip 0.075" Thick, 1" Width, Black (56" Length)	1
31	29705T86 (male)	Plastic Buckle for 1" Wide Webbing (Male)	1
32	29705T86 (female)	Plastic Buckle for 1" Wide Webbing (Female)	1
33	604-00012-01	GAS-BRAKE-PEDAL-ASSY-HALL-EFFECT	1
34	850-00028-01	HP EliteDesk 705 G4 MT (GT1030 Video Card)	1
35	330-00004-01	150W-12V-POWER-SUPPLY-MEANWELL-AUTOSW-LOWLEAK	1
36	500-00193-01	320W-12V-DUAL-VOLT-PS	1
37	442-00001-01	LINE-FILTER-CORCOM-6MV1	1
38	2-1-11-00-00-000	SPEAKER WOOFER-6.5" 4 OHM	1
39	2-1-10-00-00-000	5.25 FULL RANGE SPEAKER	3
40	LED—TMOLD-STRIP-MARQUEE-NT	LED-STRIP-MARQUEE-NT	1
41	LED—TMOLD-STRIP-CP-NT	LED—TMOLD-STRIP-CP-NT	1
42	60CM-RGB-LED-STRIP	60CM-RGB-LED-STRIP-UNDER-CP-NT	1
43	100cm LED Strip (RGB)	100cm LED Strip (RGB)	1
44	150CM-RGB-LED-STRIP-MAINCAB-NET	150CM-RGB-LED-STRIP-MAINCAB-NT	2
45	10cm LED Strip (white)	10cm Flexible LED Strip (White)	1
46	600-00030-01	PEDESTAL MOUNTING CHANNEL	2
47	600-00891-01	Securing Nylon Strap Plate	1
48	600-01786-01	Cruis'n Woofer Screen	1
49	600-01787-01	Cruis'n Rear Access plate	1
50	600-02542-01	TUBE-CONTROL-PANEL-NT	2
51	600-0249-01	BRACKET-CP-MOUNT-NT	2
52	600-02553-01	TRIM-RADIUS-NT	1
53	600-02554-01	TRIM-LCD-BASE-NT	1
54	600-02557-01	BRACKET-LOWER-CORNER-NT	2



Item	Part No.	Description	QTY
55	600-02562-01	CLIP-TMOLD-NT	5
56	600-02563-01	DIMOND-PLATE-MAINCAB-NT	1
57	600-02568-01	GRILL-SPEAKER-NT	3
58	600-0216-01	BRACKET-TMOLD-TOP-NT	2
59	600-02617-01	CLIP-TMOLD-VAULT-NT	1
60	603-0762-00	LED-FLAT-EXTRUSION-6-INCH	1
61	603-00978-01 603-00978-01-R 603-00978-01-O 603-00978-01-B 603-00978-01-G	HOOD-DASHBOARD-IM-NT HOOD-DASHBOARD-IM-NT-RED HOOD-DASHBOARD-IM-NT-ORANGE HOOD-DASHBOARD-IM-NT-BLUE HOOD-DASHBOARD-IM-NT-GREEN	1
62	603-00988-01	ACRYLIC-UNDER-TUBES-NT	2
63	TMOLD-MAINSIDE-NITRO	TMOLD-MAINSIDE-NITRO-61-INCHES	2
64	606-01767-01	TRANSLITE-LOWER-CORNER-NT	2
65	606-01773-01	DECAL-HOOD-NT	1
66	NITRO-TRUCKS-CONTROL-PANEL-ASSY	NITRO-TRUCKS-CONTROL-PANEL-ASSY	1
67	NITRO-TRUCKS-LCD-ASSY	NITRO-TRUCKS-LCD-ASSY	1
68	NITRO-TRUCKS-MARQUEE-ASSY	NITRO-TRUCKS-MARQUEE-ASSY	1
69	NITRO-TRUCKS-CAMERA-ASSY	NITRO-TRUCKS-CAMERA-ASSY	1
70	NITRO-TRUCKS-HARDWARE-ASSY	NITRO-TRUCKS-HARDWARE-ASSY	1
71	NITRO-TRUCKS-POWER-PLATE-ASSY	NITRO-TRUCKS-POWER-PLATE-ASSY	1

Rollbar Assembly

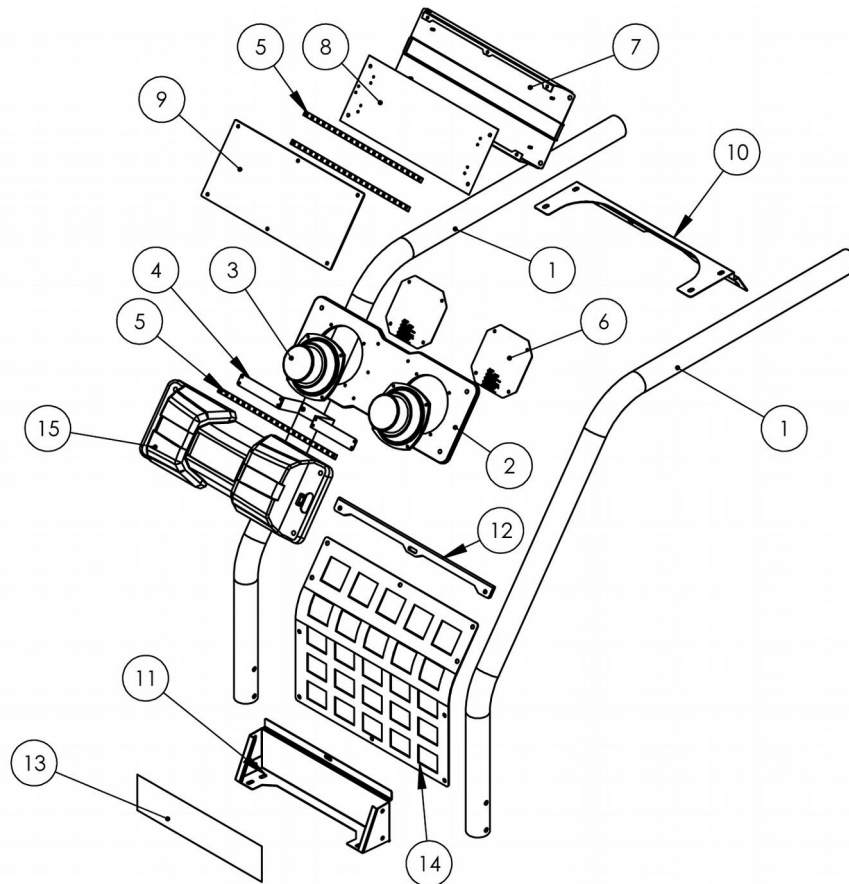

Nitro Trucks Service Manual

Rollbar Assembly Part Numbers

Item	Part No.	Description	QTY
1	600-02541-01	TUBE-ROLLBAR-NT	2
2	603-00995-01	PLATE-SPEAKER-NT	1
3	2-1-10-00-00-000	5.25 FULL RANGE SPEAKER	2
4	600-02547-01	BRACKLET-LED-SPEAKERS-NT	1
5	31CM LED STRIP (WHITE)	25cm Flexible LED Strip (White)	3
6	600-02568-01	GRILL-SPEAKER-NT	2
7	600-02545-01	BRACKET-TUBE-SIGN-NT	1
8	603-01005-01	STYRENE-TUBE-SIGN-NT	1
9	606-01759-01	TRANSLITE-LEADER-LIGHT-NT	1
10	600-02543-01	BRACKET-TOP-TUBE-NT	1
11	600-02544-01	BRACKET-BASE-TUBE-NT	1
12	600-02546-01	RETAINER-PETG-NT	1
13	606-01760-01	DECAL-TUBE-BASE-NT	1
14	600-02610-01	FABRIC-NETTING-NT	1
15	603-00979-01 603-00979-01-R 603-00979-01-O 603-00979-01-B 603-00979-01-G	SPEAKER-HOUSING-IM-NT SPEAKER-HOUSING-IM-NT-R SPEAKER-HOUSING-IM-NT-O SPEAKER-HOUSING-IM-NT-B SPEAKER-HOUSING-IM-NT-G	1

LCD Assembly

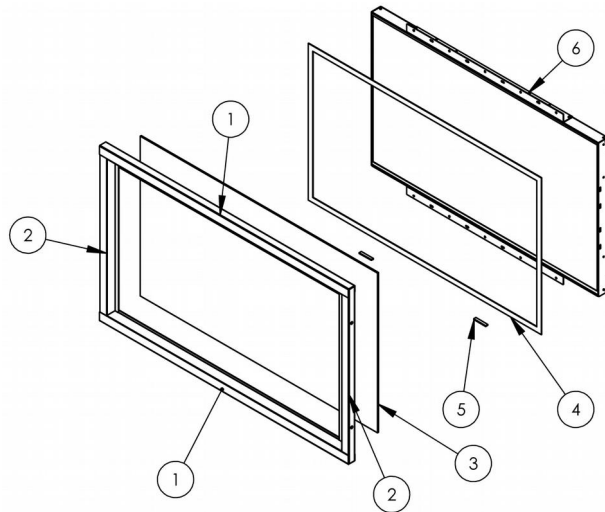

LCD Assembly Part Numbers

Item	Part No.	Description	QTY
1	600-00071-01	42" LCD Display Channel Top/Bottom	2
2	600-00072-01	42" LCD Display Channel Sides	2
3	600-00073-01	42" LCD Display Glass (Tempered)	1
4	LCD Foam Tape	1/16" T x 3/4" W x 120" Total Length – Black Foam Tape	1
5	125blackfoamtape-small	1/8" x 3/8" W x 2" L Black Foam Tape	2
6	MT43W-267C3-20151106	MAKVISION-43-INCH-LCD	1

Seat Cabinet Assembly

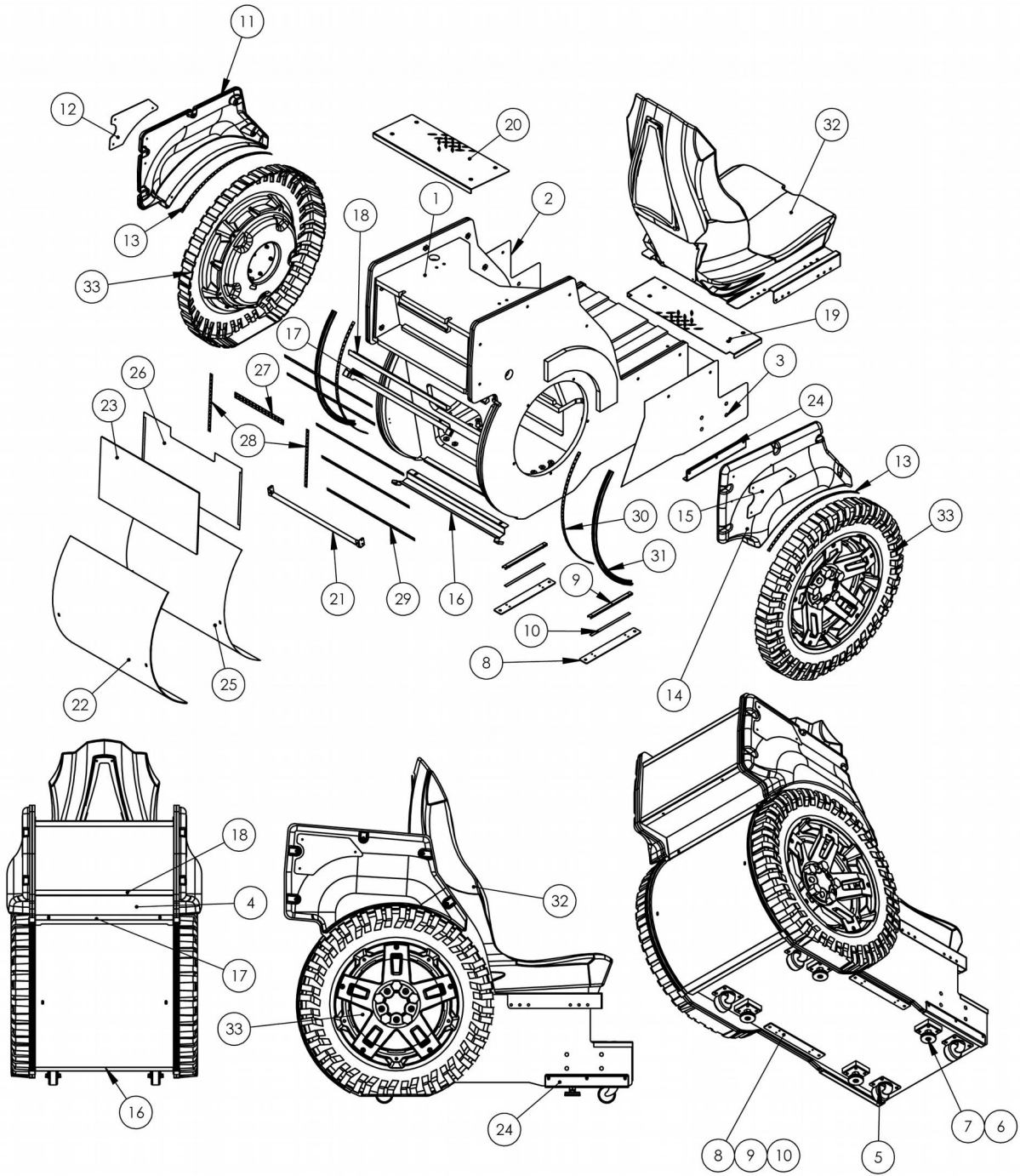

Nitro Trucks Service Manual

Seat Cabinet Assembly Part Numbers

Item	Part No.	Description	QTY
1	601-00878-01	ASSY-WOOD-SEATCAB-NITRO-TRUCKS	1
2	606-01755-01	DECAL-LEFT-SIDE-SEATCAB-NT	1
3	606-01756-01	DECAL-RIGHT-SIDE-SEATCAB-NT	1
4	606-01776-01	SEATCAB-REAR-DECAL-NT	1
5	CASTER 2'5	STD-2.50-CASTER	4
6	Leg leveler plate	2.50 x 2.50 x 1/2-13 CTR – LEVELER PLATE	4
7	Leg Leveler 1_2 x 3 inch	1/2-13 x 4" Length	4
8	603-00989-01	PETG-UNDER-CABINET-NT	2
9	600-02590-01	CHANNEL-LED-NT	2
10	20CM LED STRIP (RGB)	20cm Flexible LED Strip (RGB)	2
11	603-00983-01 603-00983-01-R 603-00983-01-O 603-00983-01-B 603-00983-01-G	LEFT-FENDER-VACFORMED-NT LEFT-FENDER-VACFORMED-NT-RED LEFT-FENDER-VACFORMED-NT-ORANGE LEFT-FENDER-VACFORMED-NT-BLUE LEFT-FENDER-VACFORMED-NT-GREEN	1
12	606-01782-01	SCREENED-LEFT-FENDER-GRAPHIC-NT	1
13	60CM-RGB-LED-STRIP	50CM-WHITE-LED-STRIP-FENDER-NT	2
14	603-00984-01 603-00984-01-R 603-00984-01-O 603-00984-01-B 603-00984-01-G	RIGHT-FENDER-VACFORMED-NT RIGHT-FENDER-VACFORMED-NT-RED RIGHT-FENDER-VACFORMED-NT-ORANGE RIGHT-FENDER-VACFORMED-NT-BLUE RIGHT-FENDER-VACFORMED-NT-GREEN	1
15	606-01783-01	SCREENED-RIGHT-FENDER-GRAPHIC-NT	1
16	600-02559-01	RETAINER-ARCH-BASE-NT	1
17	600-02560-01	RETAINER-ARCH-TOP-NT	1
18	600-02561-01	RETAINER-TAILGATE-NT	1
19	600-02564-01	DIAMOND-PLATE-SEATCAB-NT	1
20	600-02565-01	DIAMOND-PLATE-TAILGATE-NT	1
21	600-02579-01	BRACKET-TRANSLITE-NT	1
22	603-00992-01	PETG-SEATCAB-ARCH-NT	1
23	603-00993-01	PETG-TAILGATE-NT	1
24	603-01002-01	TMOLDING-CLIP-12INCH-CLEAR	2
25	606-01768-01	TRANSLITE-SEATCAB-ARCH-NT	1
26	606-01769-01	TANSLITE-TAILGATE-NT	1
27	25CM LED STRIP	25CM LED STRIP (RED)	2
28	25CM LED STRIP	25CM LED STRIP (RGB)	2
29	45CM LED STRIP (WHITE)	45CM LED STRIP (WHITE)	5
30	60CM-RGB-LED-STRIP	RGB-LED-STRIP-SEATCAB-NT	2
31	TMOLD-SEATSIDE-NITRO	TMOLD-SEATSIDE-NITRO-25-INCHES-LG	2
32	NITRO-TRUCKS-SEAT-ASSY	NITRO-TRUCKS-SEAT-ASSY	1
33	NITRO-TRUCKS-WHEEL-ASSY	NITRO-TRUCKS-WHEEL-ASSY	1

Control Panel Assembly

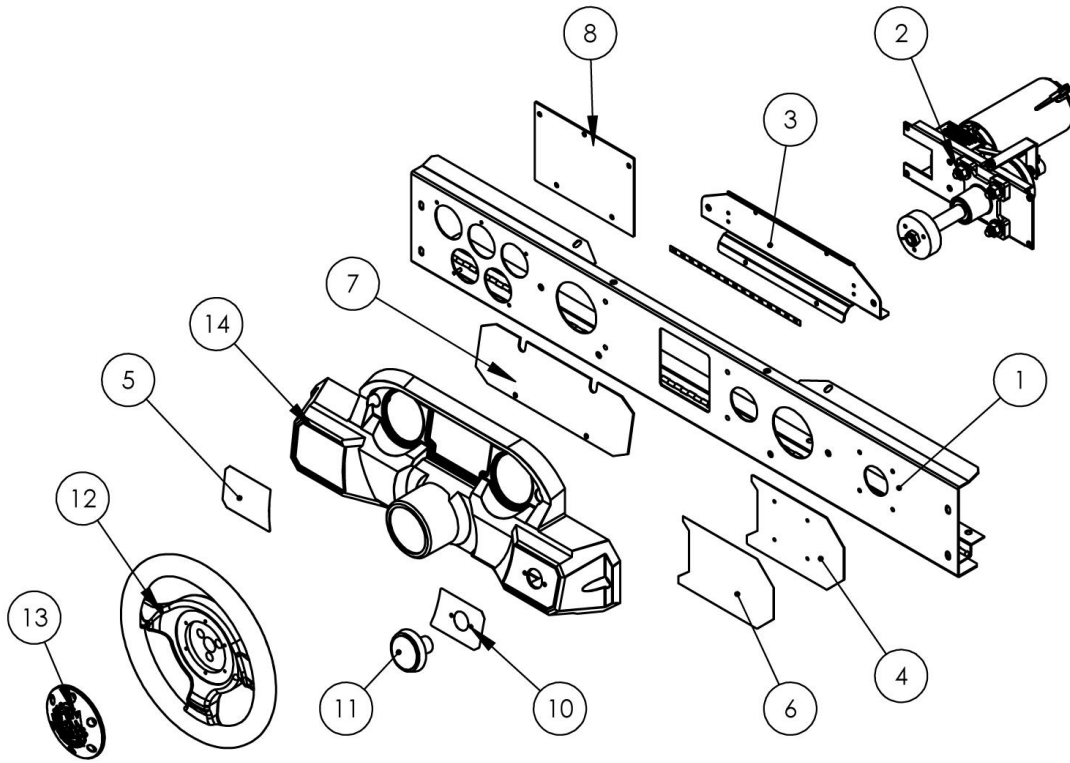

Control Panel Assembly Part Numbers

Item	Part No.	Description	QTY
1	600-02548-01	CONTROL-PANEL-NT	1
2	604-00002-00	HAPP-STEERING-MECH-ASSY	1
3	600-02550-01	BRACKET-CP-LED-NT	1
4	600-02551-01	PLATE-BLANK-CP-NT	1
5	606-01762-01	DECAL-CP-NT	1
6	606-01774-01	DECAL-BLANK-PLATE-NT	1
7	606-01765-01	TRANSLITE-GAUGES-NT	1
8	606-01766-01	TRANSLITE-SIDE-GAUGES-NT	1
9	25CM-WHITE-LED-STRIP	25cm Flexible LED Strip (White)	1
10	606-01763-01	DECAL-CP-BUTTON-NT	1
11	702-00054-00	LARGE RND – YELLOW-‘RAM’-PUSH-BUTTON	1
12	2-1-03-00-00-001	STEERING-WHEEL-SOFT-HAPP	1
13	603-00789-01	Cruis’n Steering Wheel Cap	1
14	603-00977-01 603-00977-01-R 603-00977-01-O 603-00977-01-B 603-00977-01-G	DASHBOARD-IM-NT DASHBOARD-IM-NT-RED DASHBOARD-IM-NT-ORANGE DASHBOARD-IM-NT-BLUE DASHBOARD-IM-NT-GREEN	1

Marquee Assembly

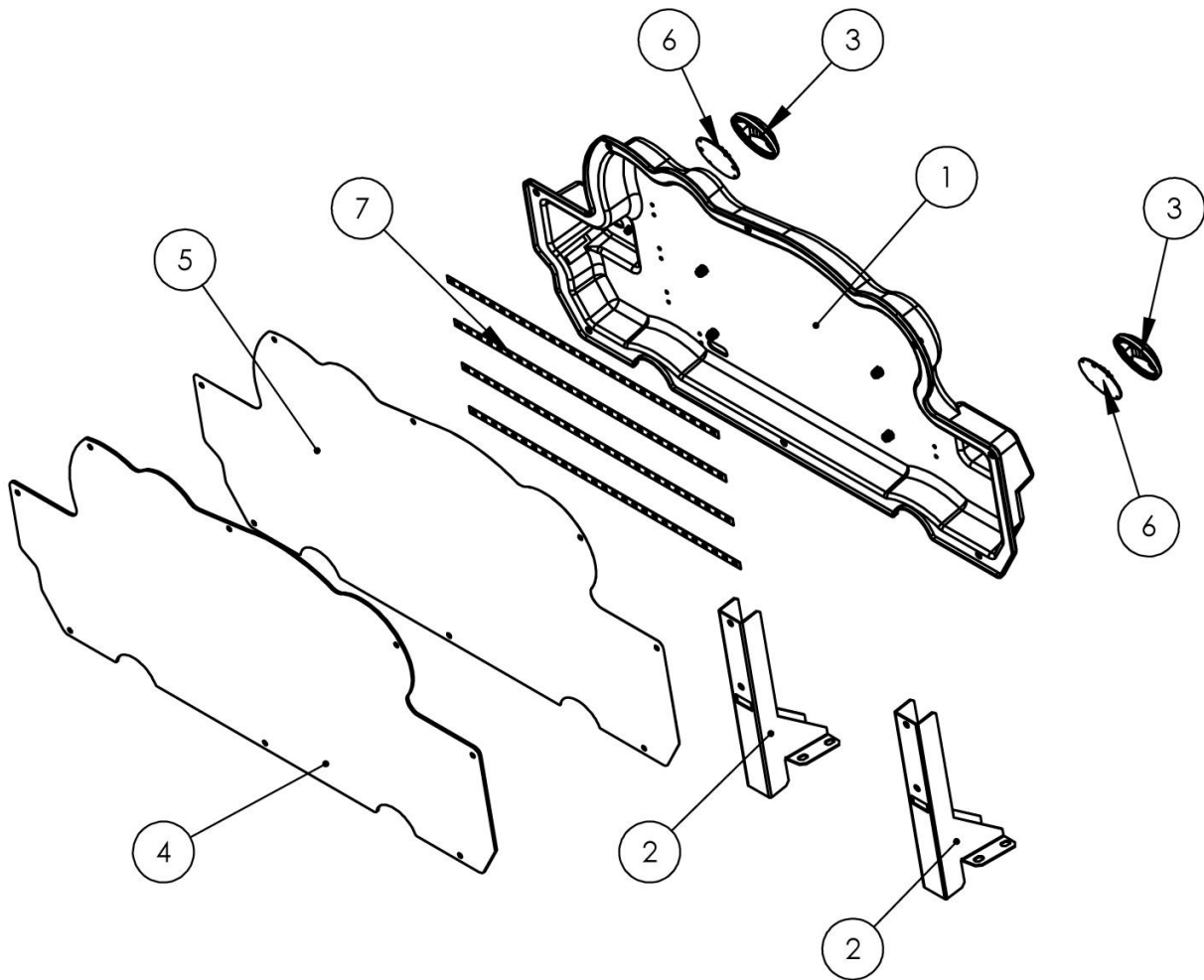

Marquee Assembly Part Numbers

Item	Part No.	Description	QTY
1	603-00985-01	MARQUEE-VACFORM-NT	1
2	600-02555-01	BRACKET-MARQUEE-NT	2
3	603-00540-01	LED Spotlight Lens – CLEAR TINT	2
4	603-00990-01	PETG-LOGO-MARQUEE-NT	1
5	606-01764-01	TRANSLIT-LOGO-MARQUEE-NT	1
6	500-00064-01	WHITE LED PUCK LIGHT	2
7	45CM LED STRIP (WHITE)	45CM LED STRIP (WHITE)	4

Wheel Assembly

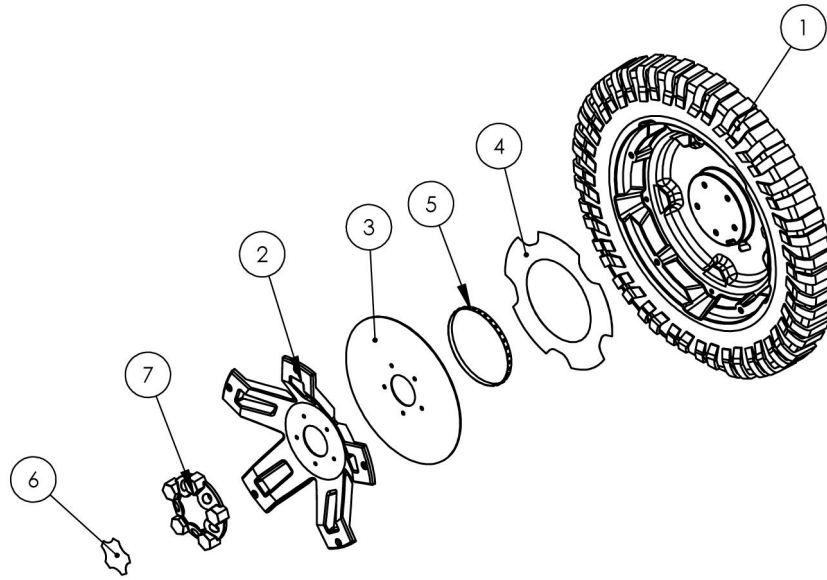

Wheel Assembly Part Numbers

Item	Part No.	Description	QTY
1	603-00982-01	TIRE-VACFORMED-W-PAINT-NT	1
2	603-00981-01	WHEEL-SPOKES-IM-NT	1
3	603-00994-01	PETG-CLEAR-WHEEL-LED-COVER	1
4	606-1757-01	WHEEL-DISC-DECAL	1
5	WHEEL-LED-STRIP	WHEEL-LED-STRIP	1
6	606-01758-01	DECAL-WHEEL-HUB- NT	1
7	603-00980-01 603-00980-01-R 603-00980-01-O 603-00980-01-B 603-00980-01-G	WHEEL-HUB-IM-NT WHEEL-HUB-IM-NT-RED WHEEL-HUB-IM-NT-ORANGE WHEEL-HUB-IM-NT-BLUE WHEEL-HUB-IM-NT-GREEN	1

Seat Assembly

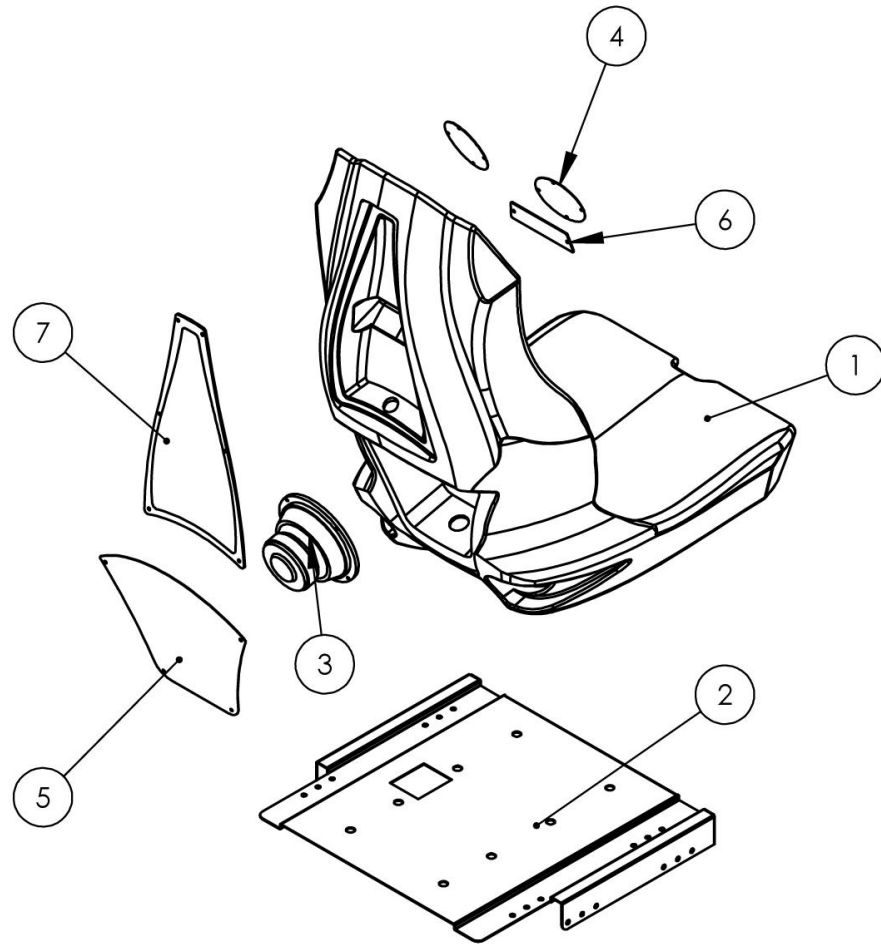

Seat Assembly Part Numbers

Item	Part No.	Description	QTY
1	603-00523-01	PLASTIC-GRAY-ROTO-SEAT	1
2	600-02558-01	BRACKET-SEAT-PAN-NT	1
3	2-1-11-00-00-000	SPEAKER WOOFER-6.5" 4 OHM	1
4	600-00105-01	SEAT-HEADREST-SPEAKER-GRILL	2
5	600-00106-01	WOOFER-GRILL	1
6	600-00620-01	MIDDLE-SEAT-PLATE	1
7	606-01770-01	TRANSLITE-SEATBACK-NT	1

Hardware Assembly

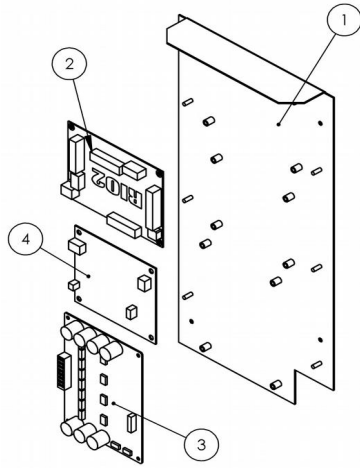

Hardware Assembly Part Numbers

Item	Part No.	Description	QTY
1	600-02576-01	RIO2-BACKPLANE-NITRO	1
2	500-00199-05	PCB-ASSY-RIO2	1
3	380-00010-01	8-CHANNEL-AUDIO-AMP-PCBA	1
4	500-00251-01	USB-H-BRIDGE-MOTOR-DRIVER-PCBA	1

Power Plate Assembly

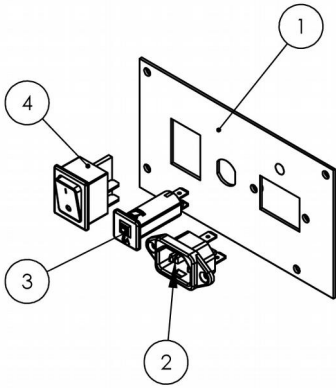

Power Plate Assembly Part Numbers

Item	Part No.	Description	QTY
1	600-01681-01	PLATE, AC – LINE FILTER, CIRCUIT BREAKER, ON/OFF SW	1
2	Power Inlet Receptacle	IEC Appliance Inlet, Screw-on Mounting, Front side, quick-connect 10A	1
3	T9-611-5A	5A-Circuit Breaker, Snap-in type, Fuseholder style, 1 pole (Schurter #4404.0007)	1
4	1832-33-12	AC-SWITCH-15AMP-125V-HEILAND-ELECT	1

Camera Assembly

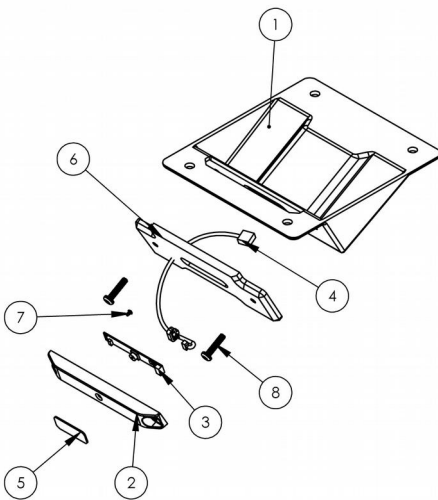

Camera Assembly Part Numbers

Item	Part No.	Description	QTY
1	603-00802-01	Cruis'n – Camera Box	1
2	603-00764-01	Camera-Housing/Moto-GP.SLDPRT	1
3	500-00185-01	Moto-GP Webcam	1
4	810-00162-01	USB camera cable	1
5	600-01790-01	Camera Dust Cover	1
6	600-01874-01	Cruis'n-Camera Acrylic Black	1
7	99461A605	MMC 99461A605 Pan Head Phillips 18-8 Stainless Steel 1-32-#0 Drive	2
8	93701A408	8-32x3/4 TORXTAMPER-BLK	2

System Diagrams

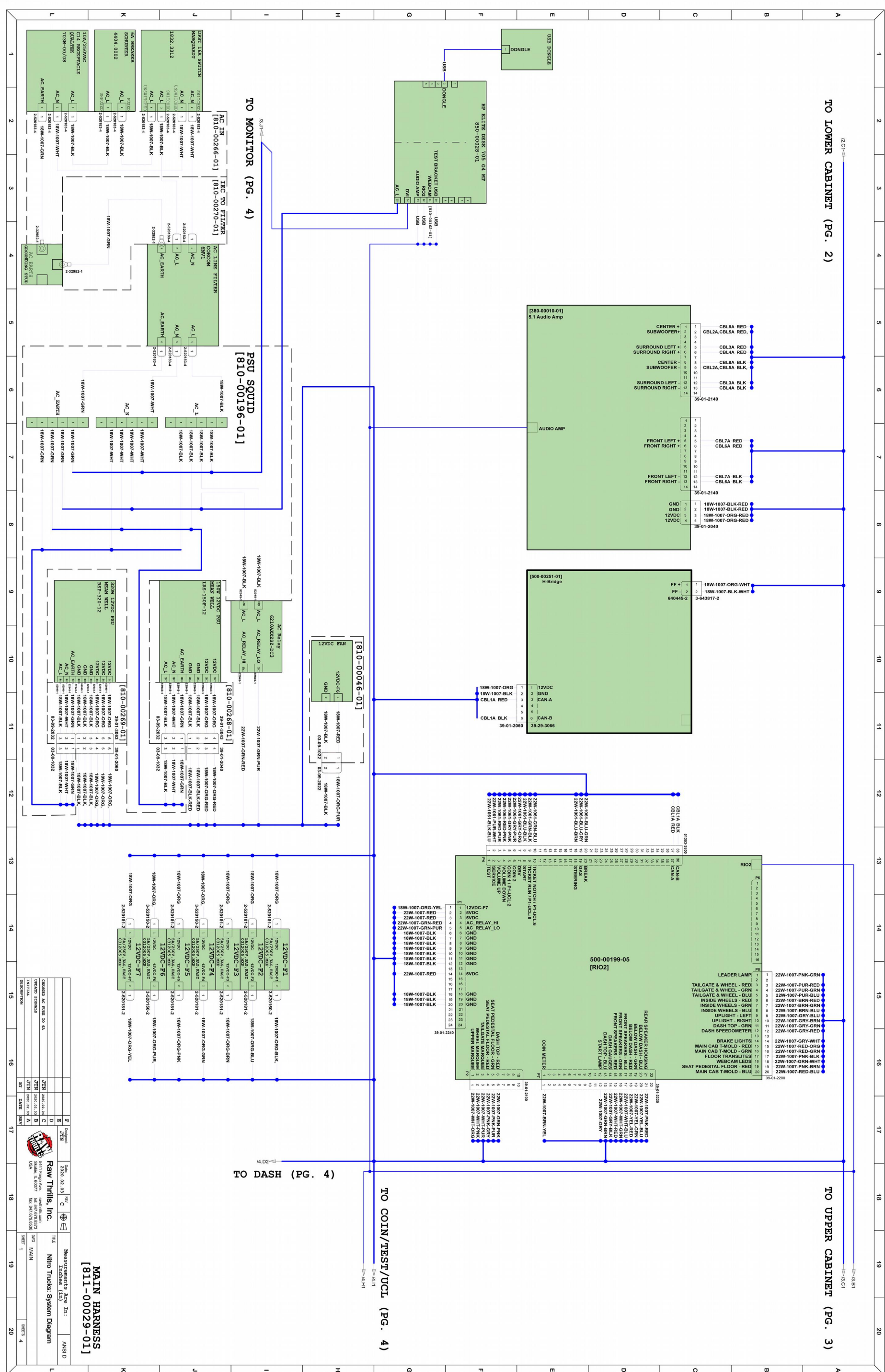

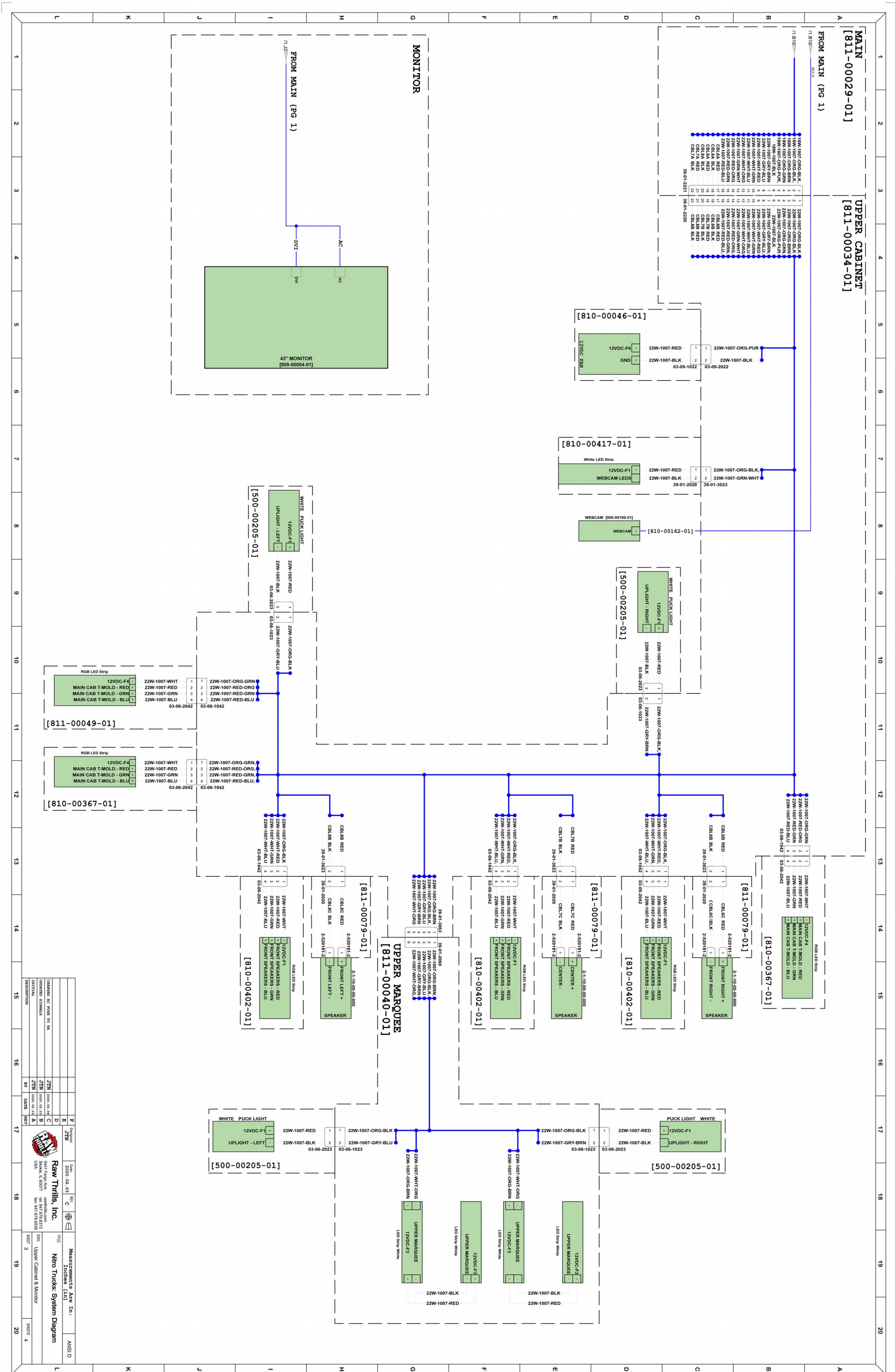

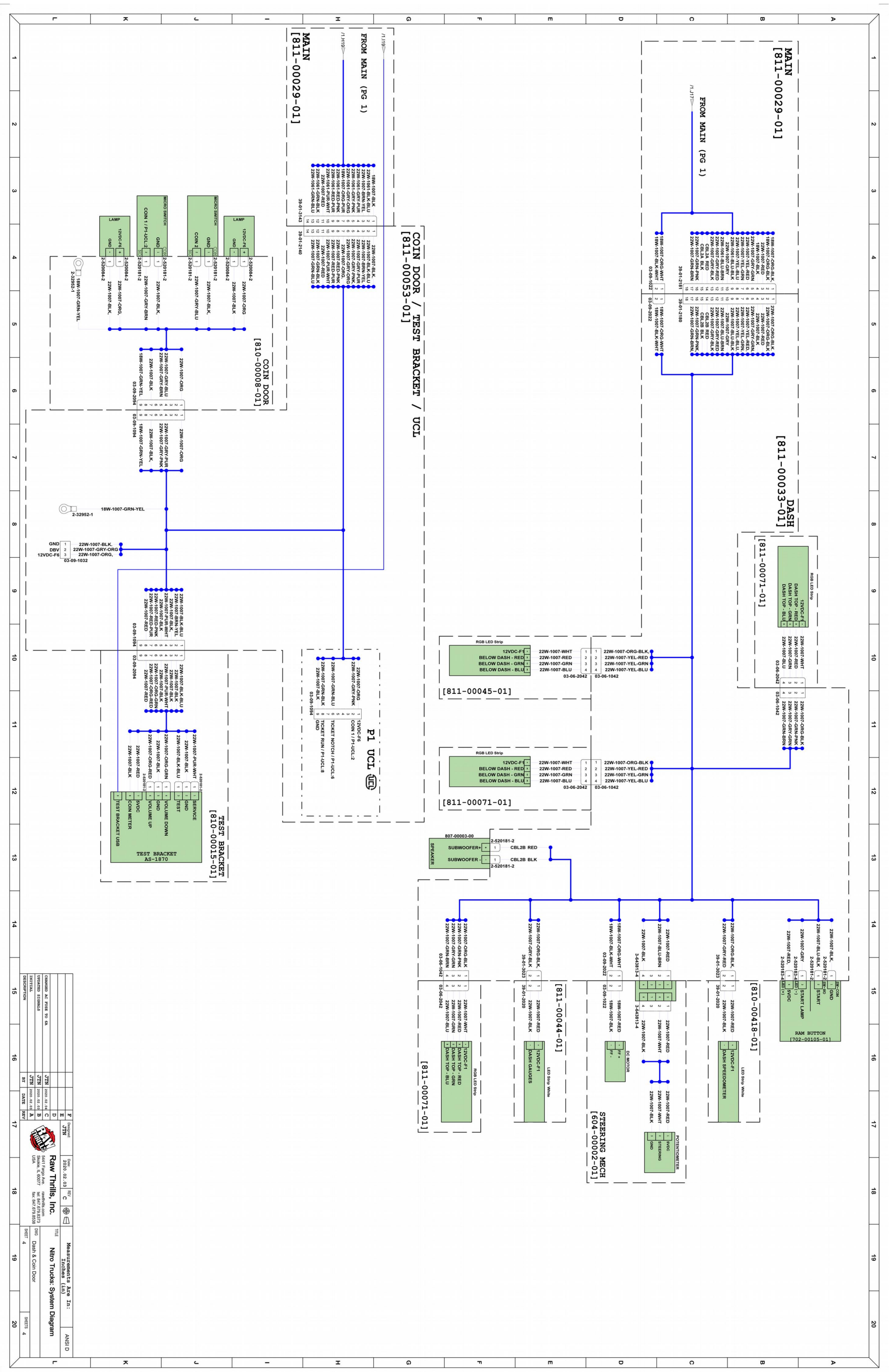

DATE	2020 02 03	REV	C
DESIGNED BY	JTN	DRAWN BY	JTN
CHECKED BY	JTN	DATE	
INITIALS	JTN	DATE	
DESCRIPTION	DASH & COIN DOOR		
Raw Thrills, Inc. 1700 S. 10th Street Suite 100 Las Vegas, NV 89102 USA			
TITLE Nitro Trucks: System Diagram		MEASUREMENTS AND UNITS Inches (In)	
SHEET 4		ANSIC D	

Contact Information

For an authorized distributor near you, visit Raw Thrills at <http://www.rawthrills.com/sales-service>

For service, contact your local distributor or your local Betson office for sales, technical information, warranty or repair. Betson can be reached at (800) 524-2343 Fax (201) 438-4837 www.betson.com

Betson Enterprises Headquarters
303 Paterson Plank Rd.
Carlstadt, NJ 07072
(800) 524-2343 or (201) 438-1300
fax (201) 438-4837