

1 1x

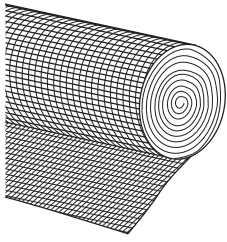

2 1x

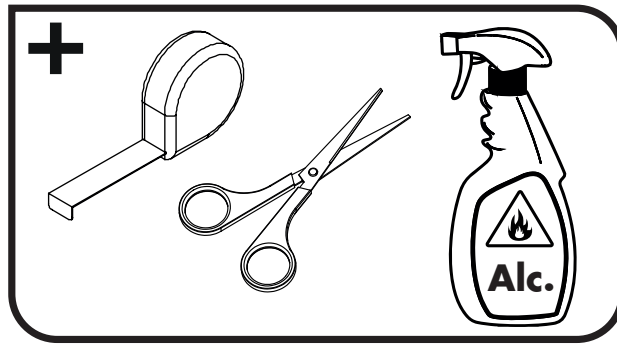
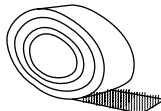

1

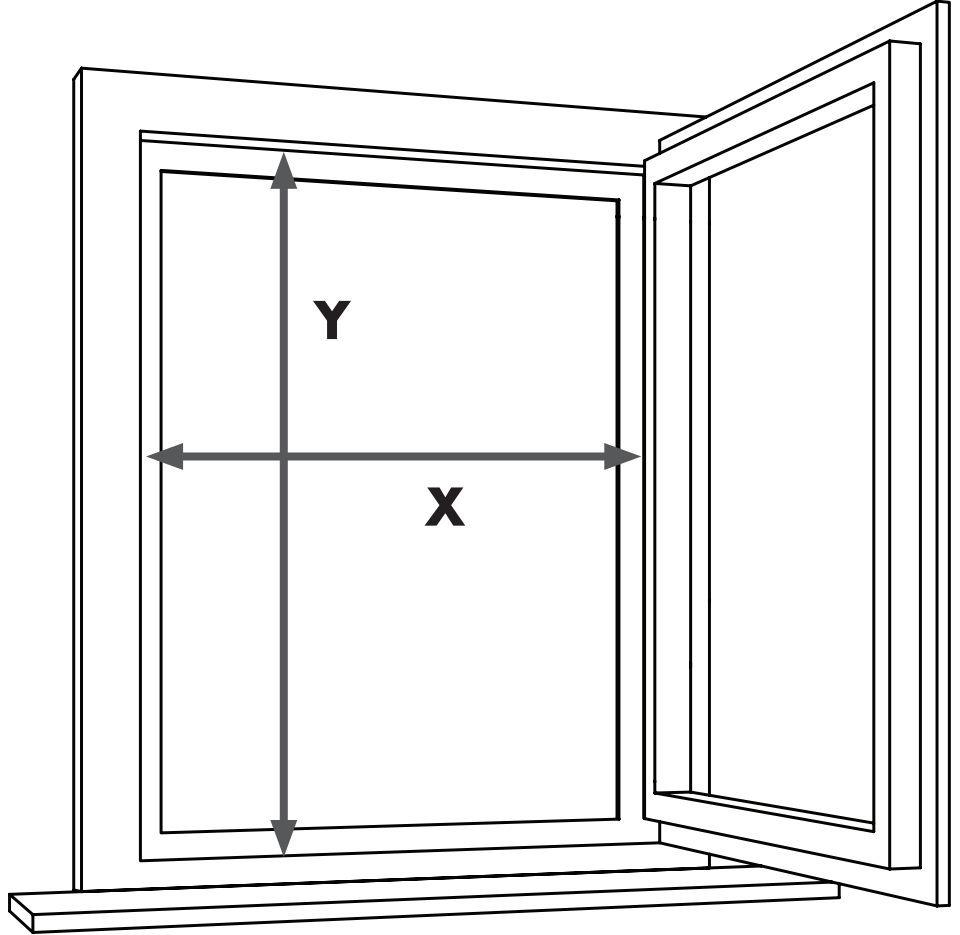
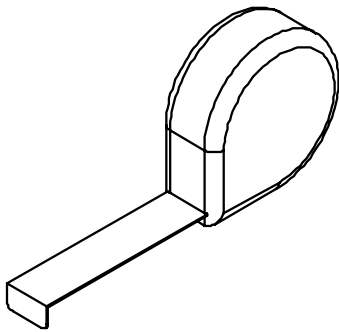

X =

Y =

2

2 1x

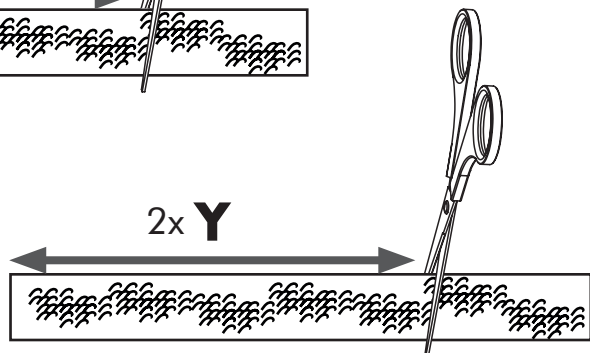
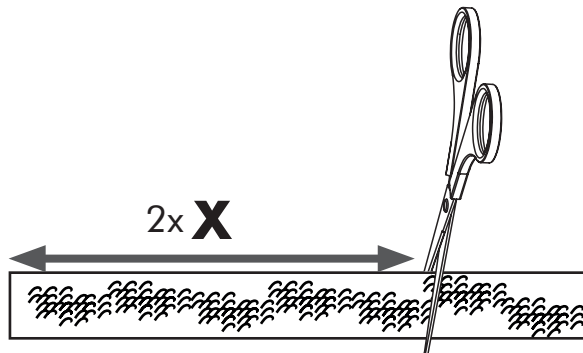
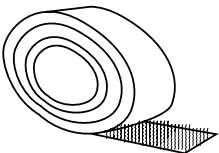

3

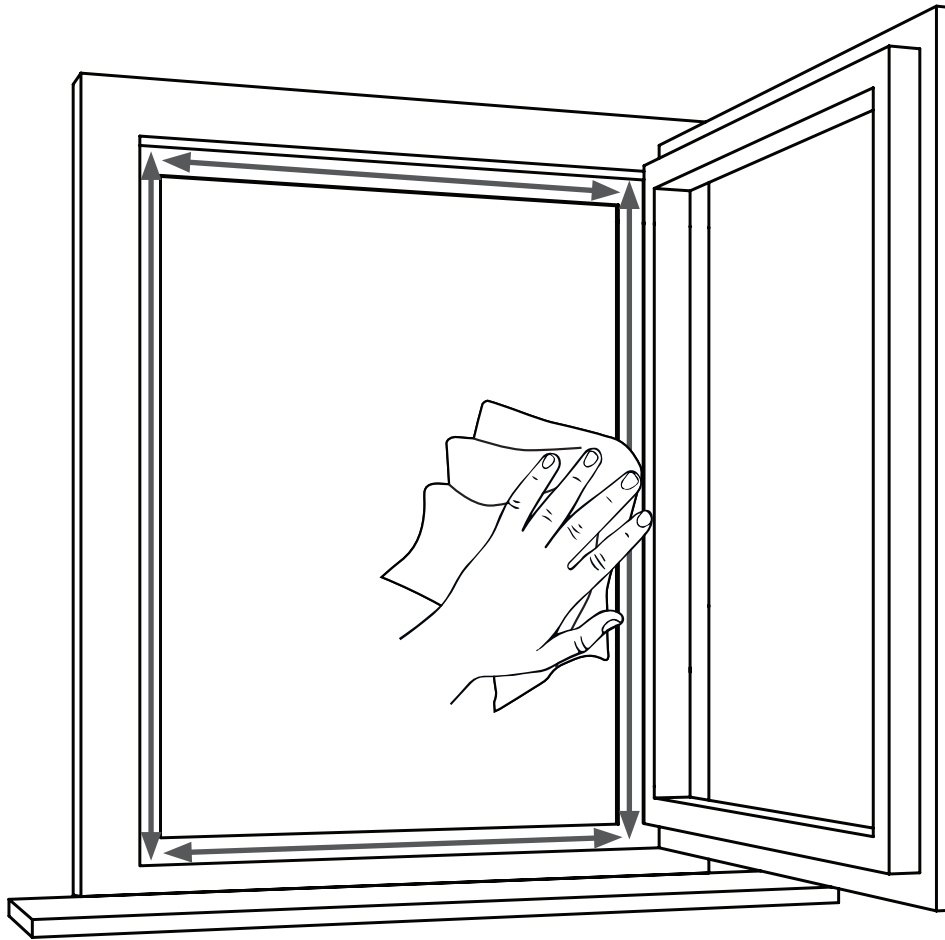
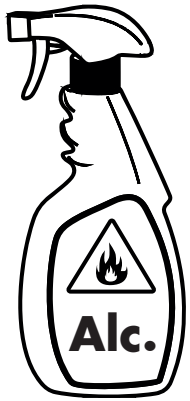

4

a

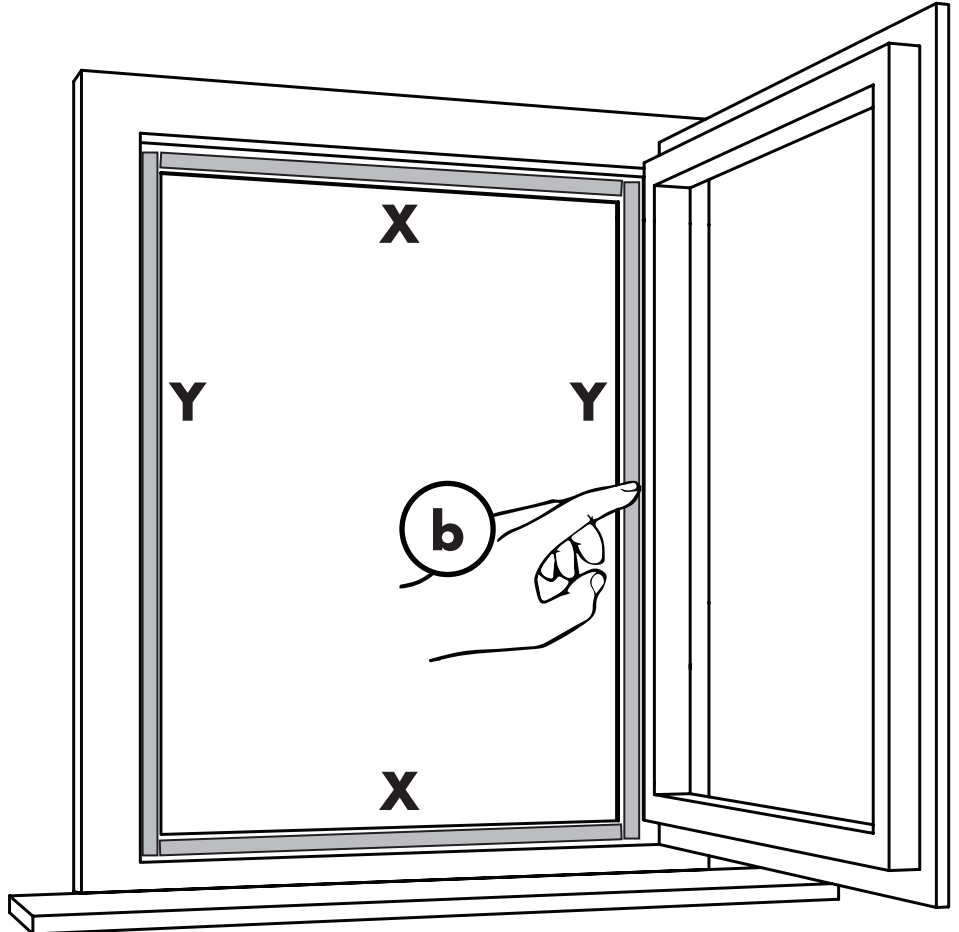
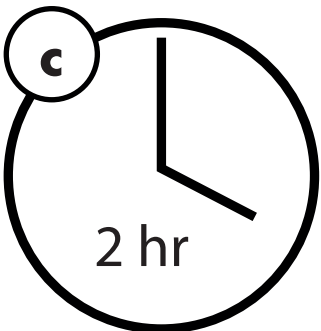
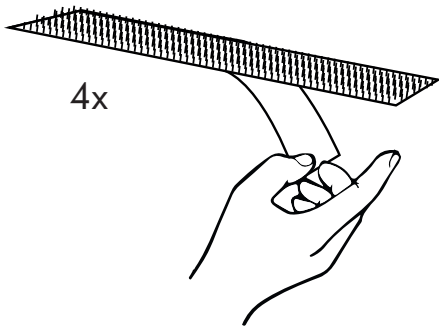

5

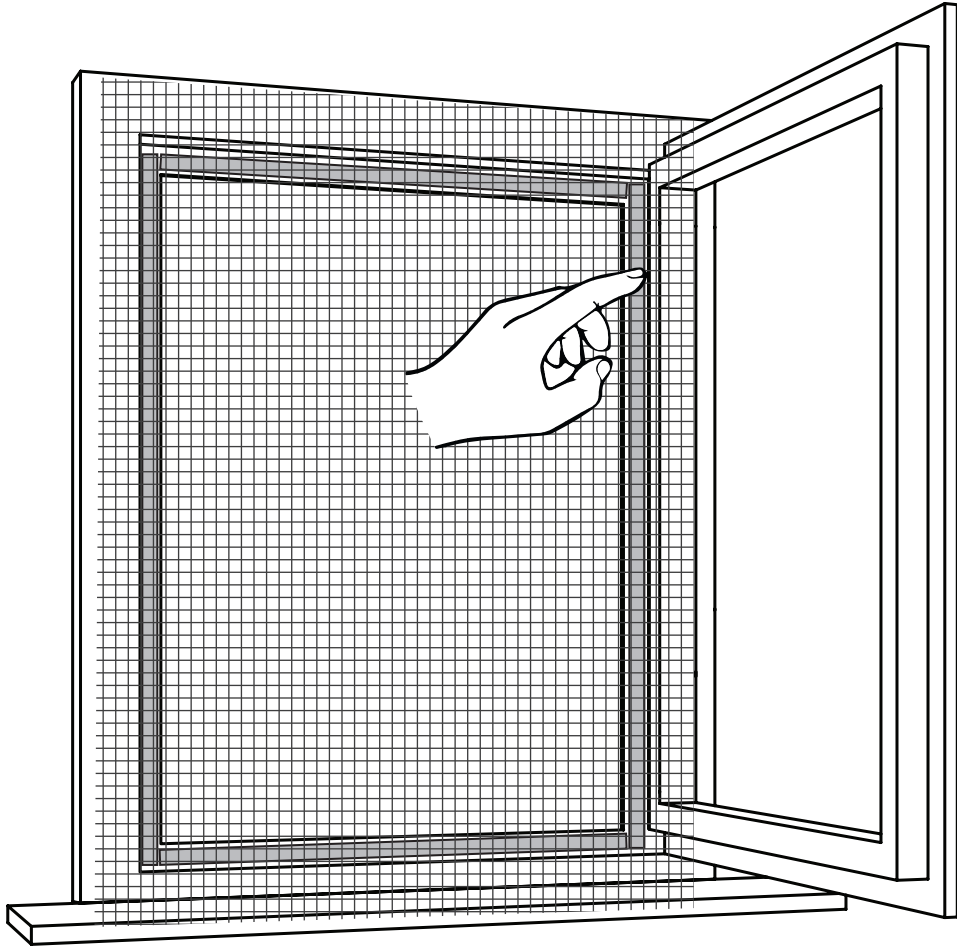

6

