

BREEZE CONSTANT-TORQUE HEAVY DUTY



- ① Custom designed stainless steel Belleville washer springs
- ② Inner liner which protects all types of hoses from damage
- ③ 10mm hexagonal screw

Constant tension clamp

The Breeze Constant-Torque® Heavy Duty (HKF) is a breakthrough in clamping technology. A Belleville spring mechanism permits the constant torque clamp to automatically increase or decrease its own diameter due to changes in operational or

environmental temperatures. The unique design eliminates “cold flow” leaks. With its 16mm band width and the 10 Belleville washer springs this clamps is the perfect solution for heavy duty applications exposed to temperature changes.

Advantages at a glance

- Increased sealing reliability across a wide temperature range
- Automatic re-tensioning during temperature changes
- Very high performance
- Per SAE standard J1508 Type “SLHD”
- Inner liner helps to maintain consistent sealing pressure

Materials



×*

*Classified by corrosion resistance. Band material S40/Screw material S10. According to DIN norms it is comparable to W2

Typical applications

- Commercial vehicle
- Industrial
- Passenger vehicle
- Infrastructure

Dimensions

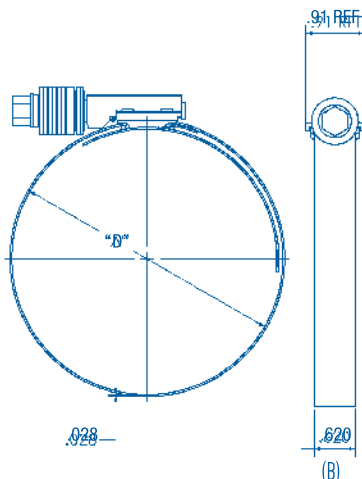

Specifications

BREEZE CONSTANT TORQUE HEAVY DUTY				
Width (B mm)	Clamping ranges (D mm)	Clamping ranges (D in.)	Belleville springs (Qty. of washers)	S10 Product No. Carbon screw
16	44-67	1 3/4-2 5/8	10	0156 8020 056
	57-79	2 1/4-3 1/8		0156 8020 068
	70-92	2 3/4-3 5/8		0156 8020 081
	83-105	3 1/4-4 1/8		0156 8020 094
	95-117	3 3/4-4 5/8		0156 8020 106
	108-130	4 1/4-5 1/8		0156 8020 119
	121-143	4 3/4-5 5/8		0156 8020 132
	133-156	5 1/4-6 1/8		0156 8020 145
	146-168	5 3/4-6 5/8		0156 8020 157