

Angebotszeichnung
QUOTATION DRAWING

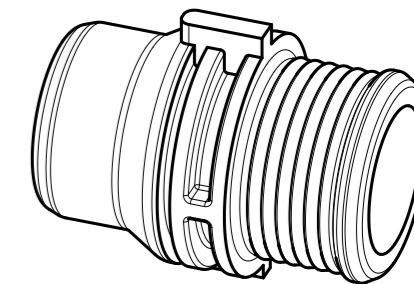

MASSSTAB/SCALE 1:1

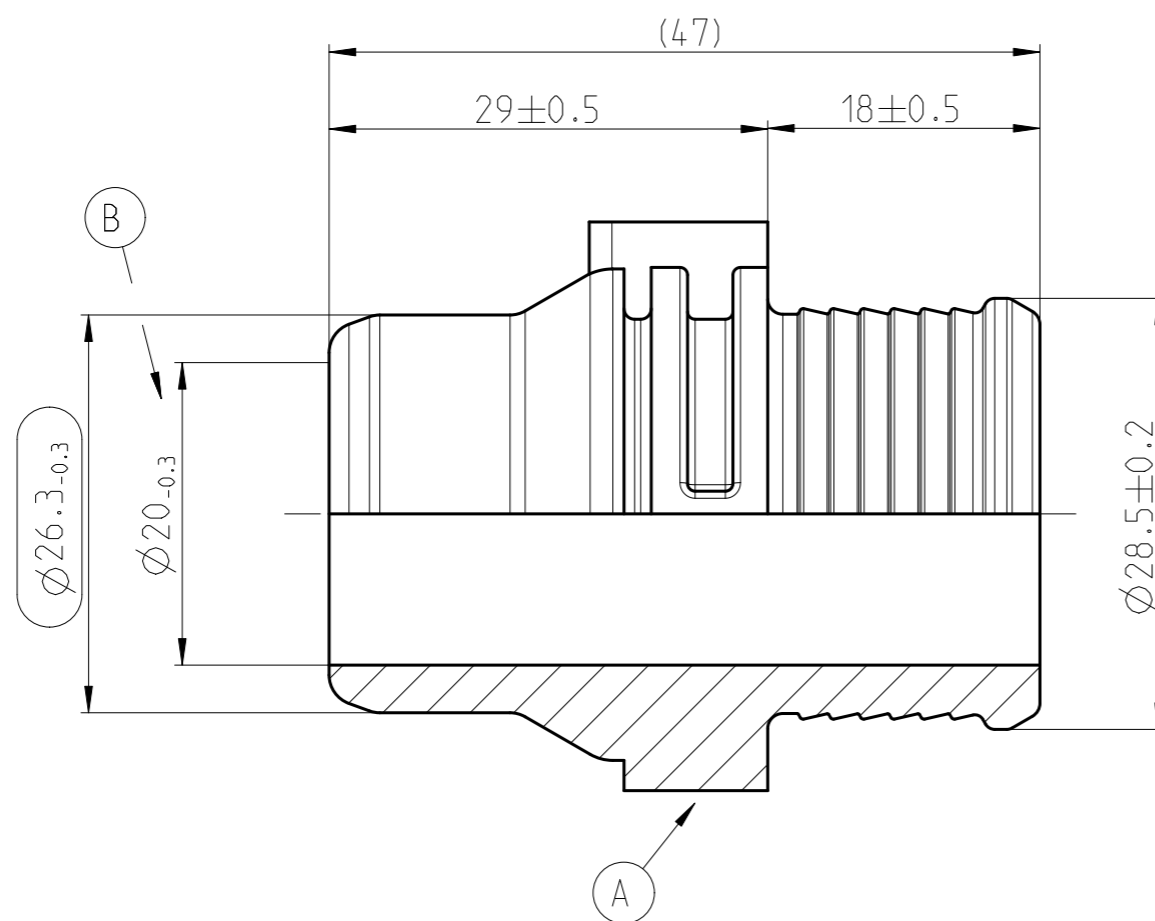

NORMAQUICK - ASSEMBLY MARKING	
Customer part-No.:	-
Trademark:	-
Manufacturer code:	NORMA-RSS
NORMA date code:	XX YY
Material code molding part:	>PA66-GF30<

-	-	-	-	-	-	-	-
-	-	-	-	-	-	-	-
-	B	1	Toleranz war/tolerance was ±0.2	606961	19.08.08	ibb/MP	Bauer
-	A	1	Materialschnitt ggf.	602839	13.12.04	Schwabauer	Bauer
INDEX Teil PART	Zeichn DWG	Anz. QTY.	Aenderung DESCRIPTION	Aend.Nr. CHANGE-NO.	Datum DATE	Bearb. DRAWN	Gepr. CHECKED

Allgemeintoleranz: GENERAL TOLERANCE:		Form- und Lagetoleranz: FORM AND POS. TOL.:		Abmass fuer Winkel: DEVIATION FOR ANGLE:		Gewicht / WEIGHT: errechnet CALCULATED gewogen actual		Volumen: VOLUME:		Pruefkennzeichnung: TEST MARKING:	
DIN 16901-130		DIN ISO 2768		±1°		-		14.1 cm ³			
Projektions-Methode 1 1st ANGLE PROJECTION DIN ISO 128-30			Material: PA66-GF30 Material-No.: - Oberflaeche: black SURF. QUAL.: DIN ISO 1302			PART NAME: Double spigot NW 20-0° NORMAQUICK PS3					
NORMA-Patentnummer: PATENT NUMBER:		Massstab: SCALE: 2:1		Datum/DATE 14.12.00		Name/NAME Imago-Gr Bahner		Benennung: Doppelstutzen NW 20-0° NORMAQUICK PS3			
Bandlaenge: LENGTH OF BAND:			Schutzvermerk nach ISO 16016 beachten CONSIDER AFTER PROTECTION NOTICE ISO 16016								
ZNE: -			Kunde/CUSTOMER:		DIN A 3		SHEET: SHEETS 1 1				
Ursprung/Anfrage: ENQUIRY-No.: 9990004288			NORMA Germany GmbH Postfach 1149 • 63461 Maintal © COPYRIGHT BY NORMA Group			Zeichnungs-Nr./DRAWING-NO.: 0702 8005 020			INDEX PART DWG 00 0B Q		
CAD-SYSTEM Pro/Engineer			DRAWING-NAME: 07028005020_Q			SUB.F.: E 3230			SUB.FROM: -		
MODEL-NAME: 07028005020						MODEL-TYP: PART					