

Angebotszeichnung
QUOTATION DRAWING

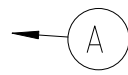

SCHNITT / SECTION A-A

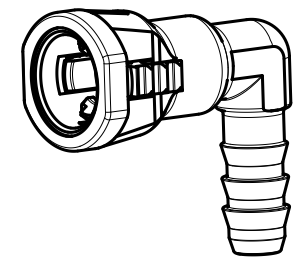
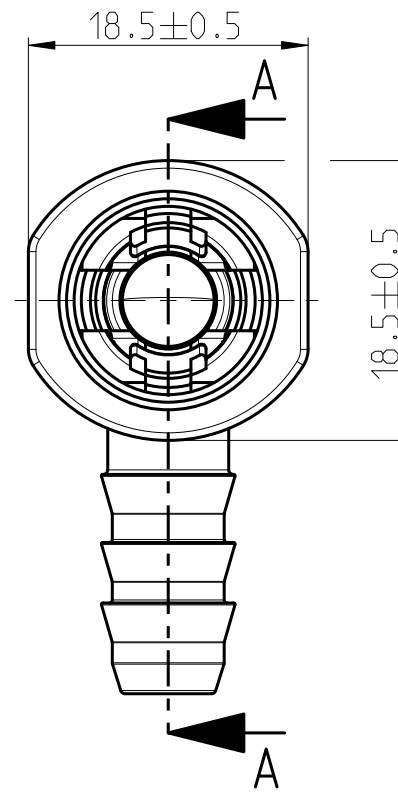
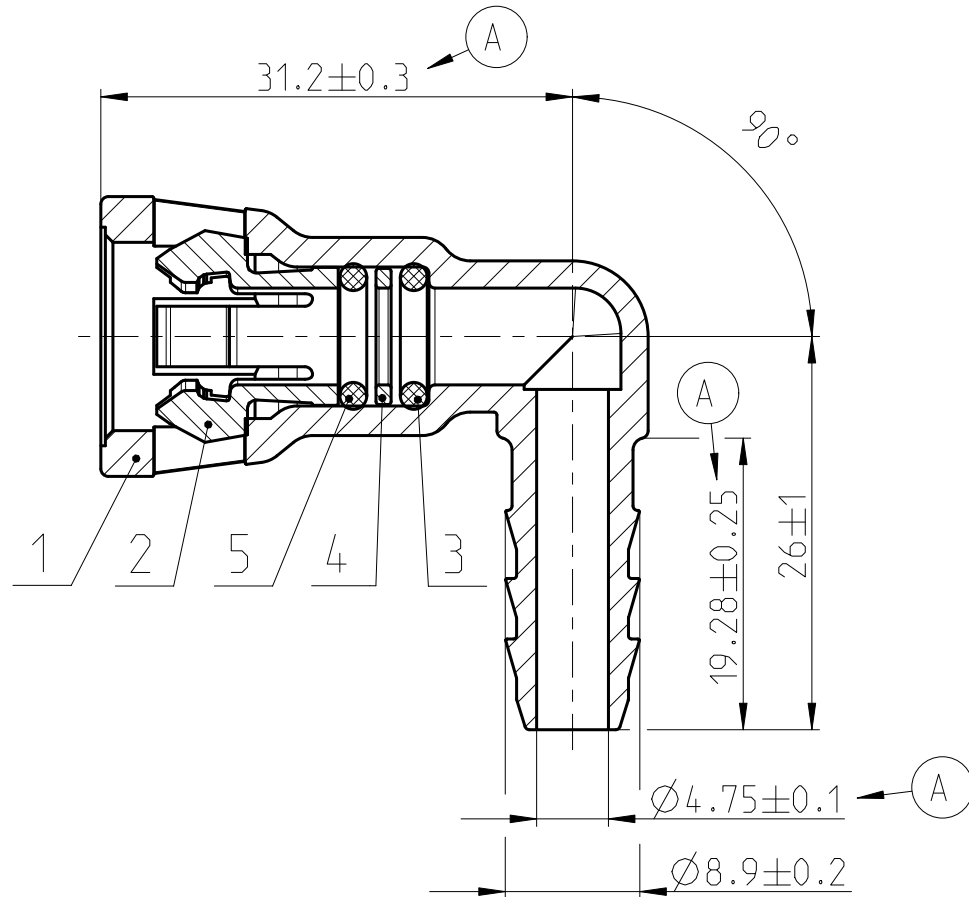

MASSSTAB / SCALE 1:1

Teil-Nr ITEM-NO	Stueck QTY	Benennung PART - NAME	Werkstoff MATERIAL	Oberflaeche SURFACE
1	1	Housing NW 1/4''-1/4''-90°	PA12-GF50	black
2	1	Retainer NW 1/4''	PA12-GF50	black
3	1	O-RING 6.07 X 1.78	FPM	black
4	1	Intermediate ring NW 1/4''	PA6-GF30	black
5	1	O-RING 6.07 X 1.78	FVMQ	blue

NORMAQUICK - ASSEMBLY MARKING	
Customer part-No.:	-
Trademark:	-
Manufacturer code:	NORMA
NORMA date code:	XX YY
Material code molding part:	>PA12-GF50<

Anschlussstutzen / Connecting spigot
gemaess / acc. to SAE J2044

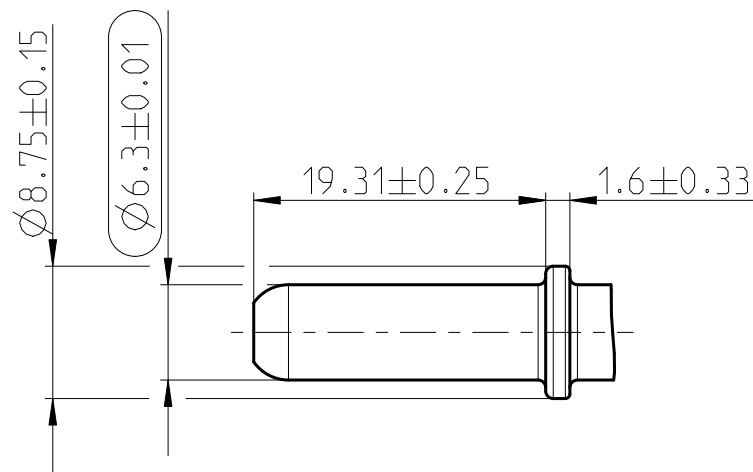

-	-	-	-	-	-	-	-	
-	C	1	Zeichnungstrennung und O-Ringfarbe in Stueckliste ergaenzt/ drawing separation and O-ring color in parts list added	-	2014-07-22	Mertens	Jacksteit	
-	B	-	Mass war Ø9.19±0.04 / dimension was Ø9.19±0.04	-	2007-05-08	ibb/HW	Jacksteit	
-	A	-	Zeichnungsrahmen neu / Symb. D-Teil und Text hinzu / Teil geaendert	-	1997-03-11	Bauer	-	
INDEX Teil PART	Zeichn DWG	Anz. QTY.	Aenderung DESCRIPTION		Aend.Nr. CHANGE-NO.	Datum DATE	Bearb. DRAWN	Gepr. CHECKED
Allgemeintoleranz: GENERAL TOLERANCE:		Form- und Lagetoleranz: FORM AND POS. TOL.:		Abmass fuer Winkel: DEVIATION FOR ANGLE:	Gewicht / WEIGHT: errechnet CALCULATED		Volumen: VOLUME:	Pruefkennzeichnung: TEST MARKING:
-		-		±2°	-		cm ³	A
Projektions-Methode 1 1st ANGLE PROJECTION DIN ISO 128-30		Material: see parts list Material-No.: - Oberflaeche: see parts list SURF. QUAL.:		PART NAME:		NORMAQUICK S NW 1/4''-1/4''-90° 4-arm-retaining spring, black for SAE spigot 6.3mm, version 1		
NORMA-Patentnummer: PATENT NUMBER:		Massstab: SCALE:	Datum/DATE		Name/NAME		Benennung:	
-		2:1	1995-09-19		Koch		NORMAQUICK S NW 1/4''-1/4''-90° 4-Arm-Haltefeder, schwarz fuer SAE Stutzen 6.3mm, Version 1	
Bandlaenge: LENGTH OF BAND:		Schutzvermerk nach ISO 16016 beachten CONSIDER AFTER PROTECTION NOTICE ISO 16016						
ZNE:		Kunde / CUSTOMER:		DIN A	SHEET: SHEETS		3 1 1	
Ursprung/Anfrage: ENQUIRY-No.:		NORMA Germany GmbH Postfach 1149 • 63461 Maintal		Zeichnungs-Nr. / DRAWING-NO.:		INDEX PART DWG		TYPE
9990001460		© COPYRIGHT BY NORMA Group		0715 8001 006		00 0C		Q
CAD-SYSTEM Pro/Engineer		DRAWING-NAME: 07158001006_Q		SUB.F.:		SUB.FROM:		MODEL-TYP: ASSEM
				MODEL-NAME: 07158001006				