

Assembly/operating instructions for SSC-LUXon surface-mounted wall light ETHIR with motion sensor

1. Intended use

This product:

- can be installed indoors and outdoors / protection type IP54, suitable for use in damp rooms,
 - must not be exposed to strong mechanical loads or heavy soiling,
 - may not be operated after damp or dirty storage until after a condition check,
 - may not be changed or modified, otherwise the operating permit and conformity will expire with immediate effect!
- It is not allowed to remove the type plate.

▲ If the aforementioned points are not observed, a short circuit or electric shock may occur! **There is danger to life!**

2. General safety instructions

- ▲ The complete installation may only be carried out by an authorized electrician who is familiar with the applicable guidelines. Hereinafter referred to as „qualified electrician“.
- ▲ For safe handling of the product, the user must have read and understood the installation/operating instructions completely before using the device for the first time.
- ▲ The product may only be used if it is alright. If the device or parts of it are defective, it must be repaired by a qualified electrician.
- ▲ This product is not a toy and is not allowed to be stored or used within the reach of children.
- ▲ Safe operation of the product is only guaranteed if these instructions are followed. Therefore, keep these assembly/operating instructions. SSC-LUXon GmbH accepts no liability if the instructions given here are not followed or the lamp is subjected to improper use.

3. Assembly & configuration

- ▲ **Caution:** The connecting cable must be disconnected from the power supply before starting work (switch off the main switch/fuse)! Only use parts which are supplied with the product or which are clearly marked as equipment! Otherwise the product may not be sufficiently safe!
- ▲ When drilling, pay attention to cables and gas and water lines.

3.1 Assembly location

The product is suitable for indoor and outdoor installation. Do not cover the product under any circumstances, especially not with insulating material!

4. Operation, faults & disorders

- ▲ **Caution:** Disconnect the power supply before starting work!
- ▲ Never look directly into the light source!

What to do in case of error?

In case of an error, the device must be switched off immediately. The product may only be operated if it works correctly. The device may only be put back into operation after it has been checked by a qualified electrician! **This is the case if:**

1. there is visible damage, 2. the product is not working correctly, 3. there is smoke, steam, or audible crackling noises, 4. overheating can be detected.

▲ **Caution:** There is a danger to life! Repairs to the product or work on parts carrying mains voltage may only be carried out by qualified electricians.

Avoidance of disturbances and fire hazards:

It is not allowed to cover the product under any circumstances. Nothing may be attached or hung on the product, especially no decoration.

5. Cleaning & care instructions

The product may only be wiped dry or carefully with a slightly damp and lint-free cloth. The product is not allowed to be removed for this purpose. Do not use abrasive or sharp objects or aggressive cleaning agents. Do not use solvents.

6. Technical data



Can be used indoors and outdoors

Type:	Wall light with motion sensor
Model:	ETHIR
Protection type:	IP54
Voltage:	220-240 V AC / 50-60 Hz
Material:	Aluminium & plastic
Operating temperature:	-5°C - +45° C
Max. power:	15 W
Colour:	Grey
Protection class:	I
Rotatable/swivelling:	Yes
Detection range:	2 - 12 m
Optimum installation height:	180 - 250 cm
Adjustable light duration:	5 sec. to 5 min.

7. Notes / explanations & legend

Important information



Disconnect the device from the mains power before starting any work



Protection class I



Installation only by qualified electrician



Vers. 06/2024

Notes on use indoors & outdoors

▲ **Protection type IP2X:** Use only indoors and dry, i.e. do not use in damp or dirty rooms and in areas of high humidity

▲ **Protection type IP4X, IP5X & IP6X:** Can be used indoors and outdoors



Onlineshop:
www.led-lichtraum.de



Satisfied with your product?
Then we look forward to your product review in our online store, on Amazon or eBay!

Disposal instructions

Make sure to dispose packaging in accordance with the applicable guidelines of your local authority. Devices marked with the crossed-out waste garbage do not belong in the household waste! You are obliged to hand in these devices at one of the free collection points in your municipality. You

can obtain more information from your local authority, the relevant town hall or a local or regional waste disposal company.

▲ **Keep packaging material and small parts away from children and animals. Danger of suffocation!**

8. Assembly Instructions

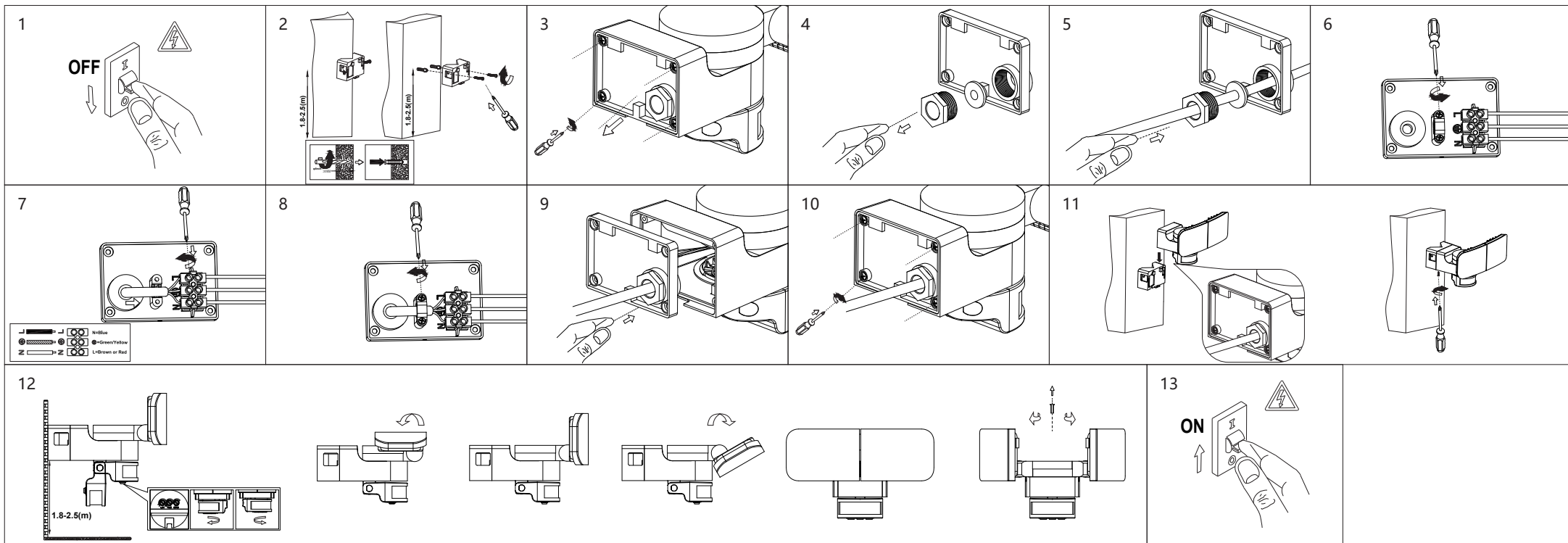

Assembly steps

1. Disconnect the connecting cable from the power supply (Fig. 1).
2. The light can be installed directly on the wall or on an outer corner. Mount the bracket in the desired position using wall plugs and screws. The optimum height is between 180 - 250 cm (Fig. 2).
3. Loosen the screws (4x) on the back & remove the cover (Fig. 3).
4. Unscrew the cable nut and seal (Fig. 4). Feed the supply cable first through the cable nut and then through the seal. **▲ Important:** Ensure that the narrow side of the seal points towards the light/back plate (Fig. 5).
5. Release strain relief fuse (Fig. 6).
6. Connect the connection cable (L, N and protective conductor if necessary) to the light (Fig. 7).
7. Tighten the strain relief lock again. **▲ Important:** Tighten by hand only (Fig. 8).
8. Screw on the cable nut and seal. Stow the cable in the light housing (Fig. 9).
9. Replace the screws (4x) on the rear including the cover (Fig. 10).
10. Place the light on the bracket (push on) and screw in the locking screw (Fig. 11).
11. Switch the connecting cable to voltage, the product is now ready for use (Fig. 13).

Setting the detection area and brightness

1. Turn the Time knob anti-clockwise to the minimum (5s). Turn the LUX knob (light sensitivity) clockwise to the maximum (towards the sun). With this position of "LUX", the light also works in daylight, making it perfect for an initial test of the function.
2. If you have not already done so, switch on the power. After a short warm-up time, the sensor can start working. When the sensor receives a signal, the lamp switches on. As long as no further signal is received, the load should stop working within 10s±3s and the lamp switches off.
3. Now set the desired time with the Time button, the brightness with the Sens button and the light sensitivity with the LUX button. To find out the desired light sensitivity, it is advisable to set this at dusk or at night.

▲ Tip: If you are installing in daylight, please turn the LUX knob to the (sun) position, otherwise you will not be able to test the light in daylight!

Solutions to problems

- The light does not work:** 1. please check whether all cables have been connected correctly and whether the main switch (fuse box) has been switched on. 2. please check whether the light is correctly connected to the power cable and whether it is generally fully functional. 3. please check whether the sensitivity settings (LUX) may be set too low.
- The motion detector is not switching correctly:** 1. please check whether there is an obstacle in front of the motion detector that is preventing the signals from being received. 2. please check whether the ambient temperature (-20° to +45°) is too high. 3. check whether the movement is within the maximum detection range (10-12 metres) 4. check whether the installation height corresponds to the height described in the technical data. 5. please check whether the motion detector has been adjusted (rotated) so that it is aligned with the area to be detected.
- The light does not switch off automatically:** 1. please check whether there is a continuous signal in the detection field e.g. trees moving due to wind etc. 2. please check whether the time has been set to the maximum position, in this case the time is set to 5 min.

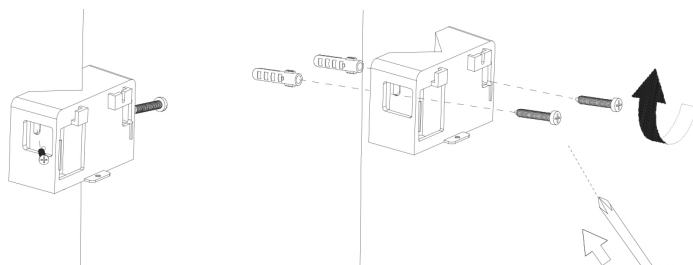

Settings

- 1: Sensitivity (LUX) - **Sun symbol:** Light also switches on in daylight. **Moon symbol:** The light only comes on in the dark. The sensitivity can be set from 5-20000lux. For switching at dusk, select approximately the centre.
- 2: Setting the light duration (TIME +/-) **Min. time** = 5 seconds - **Max. time** = 5 minutes (The light switches off after this time.)
- 3: Motion detection setting (SENS +/-) **Min. diameter:** 2 m - **Max. diameter:** 10 m (when mounted at a height of 2.5 m). **Diameter:** 10 m (for installation at a height of 2.5 m.)