

Assembly/operating instructions for SSC-LUXon energy pillar 990070732 / 990070776 with ground spike

1. Intended use

This product: -can be installed indoors and outdoors -protection type IP44, suitable for use in damp areas
-must not be exposed to strong mechanical loads or heavy soiling -may not be operated after damp or dirty storage until after a condition check -may not be changed or modified, otherwise the operating permit and conformity will expire with immediate effect! It is not allowed to remove the type plate.

▲ If the aforementioned points are not observed, a short circuit or electric shock may occur! **There is danger to life!**

2. General safety instructions

▲ The complete installation may only be carried out by an authorized electrician who is familiar with the applicable guidelines. Hereinafter referred to as „qualified electrician“.

▲ For safe handling of the product, the user must have read and understood the installation/operating instructions completely before using the device for the first time.

▲ The product may only be used if it is alright. If the device or parts of it are defective, it must be repaired by a qualified electrician.

▲ This product is not a toy and is not allowed to be stored or used within the reach of children.

▲ Safe operation of the product is only guaranteed if these instructions are followed. Therefore, keep these assembly/operating instructions. SSC-LUXon GmbH accepts no liability if the instructions given here are not followed or the lamp is subjected to improper use.

3. Assembly & configuration

▲ **Caution:** The connecting cable must be disconnected from the power supply before starting work (switch off the main switch/fuse)! Only use parts which are supplied with the product or which are clearly marked as equipment! Otherwise the product may not be sufficiently safe!

▲ The cable routing shown in the illustrations is for simplified purposes only. They in no way represent a recommendation for connection! The connection may only be carried out by a qualified electrician.

▲ When drilling, pay attention to cables and gas and water lines.

3.1 Assembly location

The product is suitable for indoor and outdoor installation. Do not cover the product under any circumstances, especially not with insulating material, fire hazard!

4. Operation, faults & disorders

▲ **Caution:** The connecting cable must be disconnected from the power supply before starting work (switch off the main switch/fuse)!

What to do in case of error?

In the event of a fault, the unit must be switched off immediately. The product may only be operated if it functions faultlessly. The unit may only be put back into operation after it has been checked by a qualified electrician! **This is the case if:**

1. there is visible damage, 2. the product is not working correctly, 3. there is smoke, steam, or audible crackling noises, 4. overheating can be detected

▲ **Caution:** There is a danger to life - repairs to the product or work on parts carrying mains voltage may only be carried out by qualified electricians.

Avoidance of disturbances and fire hazards:

It is not allowed to cover the product under any circumstances. Air circulation must be ensured. Nothing may be attached or hung on the product, especially no decoration.

5. Cleaning & care instructions

The product may only be wiped dry or carefully with a slightly damp and lint-free cloth. The product is not allowed to be removed for this purpose. Do not use abrasive or sharp objects or aggressive cleaning agents. Do not use solvents.

Assembly instructions energy pillar 990070732 / 990070776 with ground spike



1. Disconnect the connecting cable from the power supply!
2. Pull the cable connection unit out of the enclosure. Use the auxiliary rail inside for this. **Fig.1**
3. Loosen the four screws of the cable connector box and remove the cover. Connect the connecting cable to the column (luster terminal L, N & protective conductor). **Fig.2**
4. Screw the cover back on with the four screws. Make sure that the seal does not slip. Fix the outgoing cable with the strain relief. **Fig.2**
5. Guide the cable connection unit with the auxiliary rail back into the enclosure. **Fig.3**
6. **Direct mounting:** Screw the energy pillar to the desired surface with two screws. **Fig.4**
- 6.1 **Mounting with earth spike:** Screw the base plate and the spike together. Screw the ground spike to the underside of the energy pillar with the two screws & washers. Press the energy pillar into the ground with a little force. Caution: Do not hit the energy pillar with a hammer as this will damage the surface.
7. Switch the connecting cable to voltage.
8. The product is now ready for use. **Fig.5**

Technical data garden socket energy pillar



Can be used indoors and outdoors

Type:	Garden socket energy pillar ground spike
Model:	990070732 / 990070776
Protection type:	IP44
Voltage:	220-240V / 50-60Hz
Material:	Stainless steel (energy pillar) / aluminium (ground spike)
Sockets:	2
Capacity:	16A / max.3600W
Operating temperature:	-20°C - +40°C
Protection class:	I
Height:	Energy pillar 300mm / ground spike 220mm (990070776)
Base diameter:	110mm
Pillar diameter:	75mm
Colour:	Silver / metal

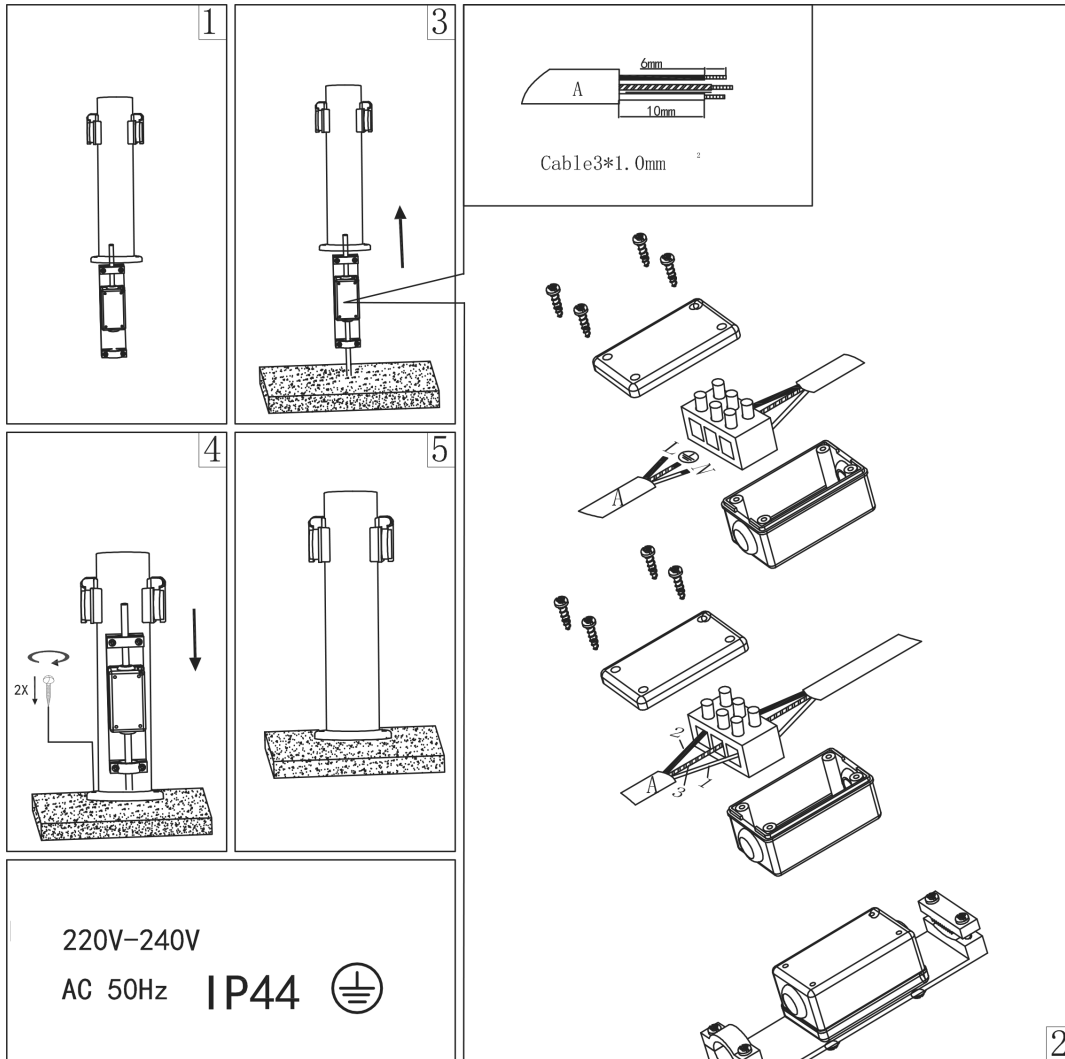



Notes / explanations & legend

Important information

-  Disconnect the device from the mains power before starting any work
-  Protection class I
-  Do not cover with insulating material
-  Installation only by qualified electrician
-  Distance to illuminated objects min. 0.5m

CE Vers. 03/2020

Notes on use indoors & outdoors

-  **Protection type IP20 & IP23:** Use only indoors and dry, i.e. do not use in damp or dirty rooms and in areas of high humidity.
-  **Protection type IP44 & IP65:** Can be used indoors and outdoors.

 Onlineshop:
www.led-lichtraum.de

 **Satisfied with your product?**
Then we look forward to your product review in our online store, on Amazon or eBay!

Disposal instructions

 Make sure to dispose packaging in accordance with the applicable guidelines of your local authority. Devices marked with the crossed-out waste garbage do not belong in the household waste! You are obliged to hand in these devices at one of the free collection points in your municipality. You can obtain more information from your local authority, the relevant town hall or a local or regional waste disposal company.

 **Keep packaging material and small parts away from children and animals. Danger of suffocation!**