

MicroLogix 1400 Programmable Controllers

Bulletin 1766 Controllers and 1762 Expansion I/O

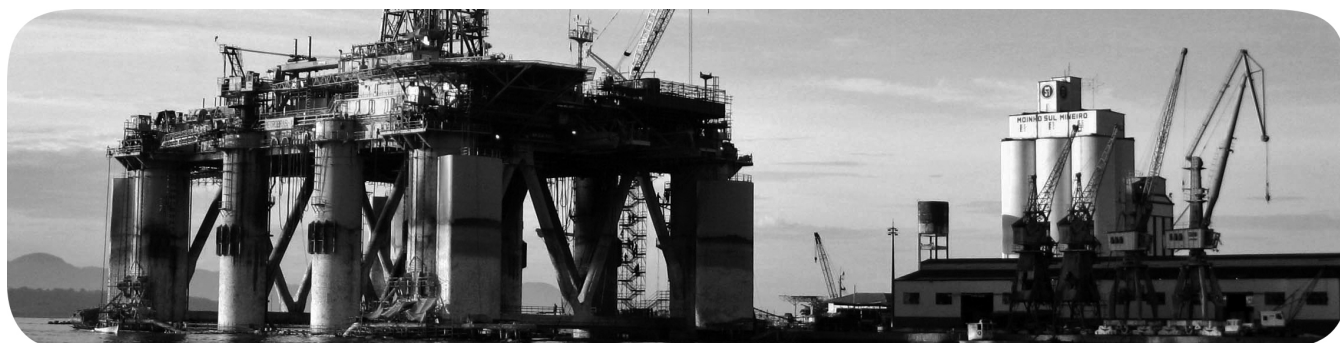

Important User Information

Solid-state equipment has operational characteristics differing from those of electromechanical equipment. Safety Guidelines for the Application, Installation and Maintenance of Solid State Controls (publication [SGI-1.1](#) available from your local Rockwell Automation sales office or online at <http://www.rockwellautomation.com/literature/>) describes some important differences between solid-state equipment and hard-wired electromechanical devices. Because of this difference, and also because of the wide variety of uses for solid-state equipment, all persons responsible for applying this equipment must satisfy themselves that each intended application of this equipment is acceptable.

In no event will Rockwell Automation, Inc. be responsible or liable for indirect or consequential damages resulting from the use or application of this equipment.

The examples and diagrams in this manual are included solely for illustrative purposes. Because of the many variables and requirements associated with any particular installation, Rockwell Automation, Inc. cannot assume responsibility or liability for actual use based on the examples and diagrams.

No patent liability is assumed by Rockwell Automation, Inc. with respect to use of information, circuits, equipment, or software described in this manual.

Reproduction of the contents of this manual, in whole or in part, without written permission of Rockwell Automation, Inc., is prohibited.

Throughout this manual, when necessary, we use notes to make you aware of safety considerations.



WARNING: Identifies information about practices or circumstances that can cause an explosion in a hazardous environment, which may lead to personal injury or death, property damage, or economic loss.



ATTENTION: Identifies information about practices or circumstances that can lead to personal injury or death, property damage, or economic loss. Attentions help you identify a hazard, avoid a hazard, and recognize the consequence



SHOCK HAZARD: Labels may be on or inside the equipment, for example, a drive or motor, to alert people that dangerous voltage may be present.



BURN HAZARD: Labels may be on or inside the equipment, for example, a drive or motor, to alert people that surfaces may reach dangerous temperatures.

IMPORTANT Identifies information that is critical for successful application and understanding of the product.

Allen-Bradley, ControlFLASH, Data Highway Plus, Data-Set, DataLiner, DH+, DTAM Micro, INTERCHANGE, MicroLogix, PanelView, PLC-5, Rockwell Automation, Rockwell Software, RSLinx, RSLogix, RSLogix 500, SLC, SLC 5/03, SLC 500, and TechConnect are trademarks of Rockwell Automation, Inc.

CIP and EtherNet/IP are trademarks of ODVA, Inc.

OPC (OLE for Process Control) is a registered trademark of the OPC Foundation.

Trademarks not belonging to Rockwell Automation are property of their respective companies.

Summary of Changes

To help you find new and updated information in this release of the manual, we have included change bars as shown to the right of this paragraph.

The table below lists the sections that document new features and additional or updated information about existing features.

Summary of Changes

Topic	Page
Added a section on how to disable serial channels.	250
Added important notes on the Disable EtherNet/IP Incoming Connections section.	283
Added a section on how to disable the Ethernet channel.	398

Product Revision History

Features are added to the controllers through firmware upgrades. See the latest release notes, [1766-RN001](#), to be sure that your controller's firmware is at the level you need. Firmware upgrades are not required, except to allow you access to the new features.

In order to use all of the latest features available with Series A controllers, RSLogix™ 500/RSLogix Micro programming software must be version 8.10.00 or higher. For Series B and Series C controllers, this should be version 8.30.00 or higher. From version 11.00.00 onwards, new processor type Series B (Enhanced Password Security) is introduced. Firmware revision FRN21 or higher supports processor type Series B (Enhanced Password Security).

To upgrade the firmware for a MicroLogix™ controller visit the Product Compatibility & Downloads web site at <http://compatibility.rockwellautomation.com/Pages/home.aspx>

Notes:

Summary of Changes	Product Revision History	3
	Preface	
	Who Should Use this Manual	13
	Purpose of this Manual	13
	Related Documentation	14
	Common Techniques Used in this Manual	14
	Chapter 1	
Hardware Overview	Hardware Features	15
	Component Descriptions	16
	MicroLogix 1400 Memory Module and Built-in Real-Time Clock	16
	1762 Expansion I/O	17
	Communication Cables	18
	Programming	19
	Programming the MicroLogix 1400 controller is done using	
	RSLogix 500/RSLogix Micro, Revision 8.10.00 or later for Series A	
	controllers and 8.30.00 or later for Series B and Series C controllers.	
	Communication cables for programming are available separately from	
	the controller and software.	19
	Firmware Revision History	19
	Communication Options	20
	Chapter 2	
Install Your Controller	Agency Certifications	23
	Compliance to European Union Directives	23
	EMC Directive	23
	Low Voltage Directive	24
	Installation Considerations	24
	Safety Considerations	25
	Hazardous Location Considerations	25
	Disconnecting Main Power	26
	Safety Circuits	26
	Power Distribution	27
	Periodic Tests of Master Control Relay Circuit	27
	Power Considerations	27
	Isolation Transformers	27
	Power Supply Inrush	27
	Loss of Power Source	28
	Input States on Power Down	28
	Other Types of Line Conditions	28
	Preventing Excessive Heat	29
	Master Control Relay	29
	Using Emergency-Stop Switches	30
	Schematic (Using IEC Symbols)	31
	Schematic (Using ANSI/CSA Symbols)	32

Installing a Memory Module	32
Using the Battery	33
Connecting the Battery Wire Connector	34
Controller Mounting Dimensions	35
Controller and Expansion I/O Spacing	35
Mounting the Controller	36
DIN Rail Mounting	37
Panel Mounting	38
1762 Expansion I/O Dimensions	39
Mounting 1762 Expansion I/O	39
DIN Rail Mounting	39
Panel Mounting	40
Connecting Expansion I/O	41

Chapter 3

Wire Your Controller

Wiring Requirements	43
Wiring Recommendation	43
Wire without Spade Lugs	44
Wire with Spade Lugs	44
Using Surge Suppressors	45
Recommended Surge Suppressors	46
Grounding the Controller	47
Wiring Diagrams	48
Terminal Block Layouts	49
Terminal Groupings	52
Sinking and Sourcing Wiring Diagrams	53
1766-L32BWA, 1766-L32AWA, 1766-L32BXB, 1766-L32BWAA, 1766-L32AWAA, 1766-L32BXBA Wiring Diagrams	53
Controller I/O Wiring	55
Minimizing Electrical Noise	55
Wiring Your Analog Channels	56
Analog Channel Wiring Guidelines	57
Minimizing Electrical Noise on Analog Channels	58
Grounding Your Analog Cable	59
Expansion I/O Wiring	59
Digital Wiring Diagrams	59
Analog Wiring	67

Chapter 4

Communication Connections

Supported Communication Protocols	75
Default Communication Configuration	76
Using the Communications Toggle Functionality	76
Changing Communication Configuration	77
Connecting to the RS-232 Port	79
Making a DF1 Point-to-Point Connection	80

Using a Modem	81
Connecting to a DF1 Half-Duplex Network.....	84
Connecting to a RS-485 Network	86
DH-485 Configuration Parameters	87
Recommended Tools	89
DH-485 Communication Cable.....	89
Connecting the Communication Cable to the DH-485 Connector..	90
Grounding and Terminating the DH-485 Network	91
Connecting the AIC+	92
Cable Selection Guide	93
Recommended User-Supplied Components	96
Safety Considerations.....	97
Install and Attach the AIC+.....	97
Powering the AIC+.....	98
Connecting to Ethernet	99
Ethernet Connections	100

Chapter 5

Using the LCD

Operating Principles.....	102
Main Menu and Default Screen.....	105
Operating Buttons.....	107
Using Menus to Choose Values.....	107
Selecting Between Menu Items	107
Cursor Display	108
Setting Values.....	109
I/O Status	109
Viewing I/O Status	110
Monitor User Defined Target Files	111
Target User Defined File Number (TUF)	111
Monitoring a Bit File	112
Monitoring Integer Files	116
Monitoring Double Integer files	121
Monitor Floating point Files	127
Monitor System Status Files.....	127
Using the Mode Switch.....	128
Controller Modes	129
Changing Mode Switch Position.....	129
Using a User Defined LCD Screen	131
User Defined LCD Screen	132
Configuring Advanced Settings	133
Changing Key In Mode.....	134
Key In Modes	134
Changing Key In Mode	134
Using Communications Toggle Functionality	136

Ethernet Network Configuration	136
Viewing Ethernet Status	136
Configuring the IP Address	138
Configuring the Ethernet Port	142
Configuring Ethernet Protocol Setup	145
Using Trim Pots	148
Trim Pot Operation	148
Changing Data Value of a Trim Pot	149
Trim Pot Configuration in LCD Function File	150
Error Conditions	150
Viewing System Information	151
Viewing Fault Code	152
Saving/Loading Communication EEPROM	153
Saving Communication EEPROM	153
Loading communication EEPROM	156
LCD setup	156
Configuring contrast value	157
Configuring the backlight	158
Protocol Configuration	159
Modbus RTU Slave Node Address	159
LCD Password Setup	162
Set the LCD Password	163
Activate the LCD Password	165
Deactivate the LCD Password	166
Change LCD Password	167

Using Real-Time Clock and Memory Modules

Chapter 6

Real-Time Clock Operation	171
Operation at Power-up and Entering a Run or Test Mode	171
Writing Data to the Real-Time Clock	171
RTC Battery Operation	172
Memory Module Operation	172
User Program , User Data, Datalog and Recipe Back-up	173
Program Compare	173
Data File Download Protection	173
Memory Module Write Protection	173
Removal/Insertion Under Power	174
Memory Module Information File	174
Program /Data Download	174
Program /Data Upload	174

Online Editing

Chapter 7

Overview of Online Editing	175
Online Editing Terms	176
Effects of Online Editing On Your System	177

	System Impacts.....	177
	Data Table File Size.....	177
	Online Edit Error	177
	Directions and Cautions for MicroLogix 1400 Online Editing User .	177
	A Download is Required Before Starting Online Editing.....	177
	Types of Online Editing	179
	Edit Functions in Runtime Online Editing	179
	Edit Functions in Program Online Editing.....	180
	Appendix A	
Specifications	Specifications for Inputs	181
	Working Voltage	186
	Expansion I/O Specifications	187
	Digital I/O Modules.....	187
	Analog Modules	193
	Appendix B	
Replacement Parts	MicroLogix 1400 Replacement Kits	201
	Lithium Battery (1747-BA)	201
	Installation	201
	Battery Handling.....	203
	Storage	203
	Transportation	203
	Disposal	205
	Appendix C	
Troubleshooting Your System	Understanding the Controller Status Indicators	207
	Controller Status LED Indicators.....	207
	Status Indicators on the LCD	208
	I/O Status Indicators on the LCD	209
	Normal Operation.....	209
	Error Conditions.....	209
	Controller Error Recovery Model.....	210
	Analog Expansion I/O Diagnostics and Troubleshooting.....	212
	Module Operation and Channel Operation	212
	Power-up Diagnostics.....	212
	Critical and Non-Critical Errors.....	213
	Module Error Definition Table.....	213
	Error Codes.....	214
	Calling Rockwell Automation for Assistance	215
	Appendix D	
Using ControlFLASH to Upgrade Your Operating System	Preparing for Firmware Upgrade	217
	Install ControlFLASH Software.....	217

Use DMK Extraction Tool for Firmware Upgrade.....	217
Prepare the Controller for Firmware Upgrade.....	221
Using ControlFLASH for Firmware Upgrade	222
ControlFLASH Error Messages	232
Missing or Corrupt OS state.....	234
Recovering from Missing or Corrupt OS State	235

Appendix E

Connecting to Networks via RS-232/RS-485 Interface

RS-232 Communication Interface	237
RS-485 Communication Interface	237
DF1 Full-Duplex Protocol	237
DF1 Half-Duplex Protocol.....	238
DF1 Half-Duplex Operation	238
Considerations When Communicating as a DF1 Slave on a Multi-drop Link	240
Using Modems with MicroLogix Programmable Controllers	240
DH-485 Communication Protocol	241
DH-485 Configuration Parameters	242
Devices that use the DH-485 Network	242
Important DH-485 Network Planning Considerations	243
Example DH-485 Connections	247
Modbus Communication Protocol	249
ASCII	249
Distributed Network Protocol (DNP3)	249
Disable Serial Channels 0 and 2.....	250

Appendix F

MicroLogix 1400 Distributed Network Protocol (DNP3)

Channel Configuration for DNP3 Slave.....	253
Channel 0 and Channel 2 Link Layer Configuration.....	255
Channel 1 Link Layer Configuration	256
DNP3 Slave Application Layer Configuration	258
Channel 0 and Channel 2 Link Layer Configuration Parameters.	260
Channel 1(Ethernet) Link Layer Configuration Parameters.....	264
DNP3 Slave Application Layer Configuration Parameters.....	269
DNP3 Slave Application Layer	284
Function Codes	284
Internal Indications.....	289
DNP3 Objects and MicroLogix 1400 Data Files	290
DNP3 Data Files	293
DNP3 Configuration Files	294
DNP3 Binary Input Object.....	298
DNP3 Binary Output Object.....	300
DNP3 Double Bit Binary Input Object.....	303
DNP3 Counter Object.....	305
DNP3 Frozen Counter Object.....	308

DNP3 Analog Input Object.....	310
DNP3 Analog Output Object.....	314
DNP3 BCD Object.....	316
DNP3 Data Set Object.....	318
Object Quality Flags.....	328
DNP3 Device Attribute Object.....	331
Event Reporting.....	334
Generating Events.....	335
DNP3 10K Event Logging.....	338
Control Generating Event.....	340
Reporting Event By Polled Response.....	341
Reporting Event By Unsolicited Response.....	342
Collision Avoidance.....	344
Time Synchronization.....	345
Download a User Program via DNP3 Network.....	346
Default Directories and Files.....	347
Generating *.IMG files using RSLogix 500/RSLogix Micro.....	347
Rules for File Authentication.....	349
Rules for Downloading a User Program.....	350
Rules for Uploading a User Program.....	352
Rules for Initializing a User Program.....	352
Rules for uploading Communication Status Files.....	352
Starting and Stopping User Programs (Mode Change) via DNP3 Network.....	353
Initialize User Program.....	353
Start User Program.....	354
Stop User Program.....	354
Diagnostics.....	354
Diagnostics for Ethernet Channel (Channel 1).....	360
Diagnostics for Secure Authentication.....	367
Function Codes.....	369
Implementation Table.....	371

Appendix G

Connecting to Networks via Ethernet Interface

MicroLogix 1400 Controllers and Ethernet Communication.....	383
MicroLogix 1400 Performance Considerations.....	384
MicroLogix 1400 and PC Connections to the Ethernet Network.....	385
Ethernet Network Topology.....	385
Connecting an Ethernet switch on the Ethernet Network.....	385
Cables.....	386
Ethernet Connections.....	388
Duplicate IP address Detection.....	389
Configuring the Ethernet Channel on the MicroLogix 1400.....	390

Configuration Using RSLogix 500/RSLogix Micro Programming
Software 392
Configuration Via BOOTP 392
 Using the Rockwell Automation BOOTP/DHCP Utility 393
Using a DHCP Server To Configure Your Processor 395
Using Subnet Masks and Gateways. 396
 Manually Configuring Channel 1 for Controllers on
 Subnets 397
MicroLogix 1400 Embedded Web Server Capability 397
Disable the Ethernet Channel 398

**System Loading and Heat
Dissipation**

Appendix H

System Loading Calculations. 399
 System Loading Example Calculations 400
System Loading Worksheet 401
 Current Loading. 401
Calculating Heat Dissipation 403

Glossary

Index

Read this preface to familiarize yourself with the rest of the manual. It provides information concerning:

- who should use this manual
- the purpose of this manual
- related documentation
- conventions used in this manual
- Rockwell Automation® support

Who Should Use this Manual

Use this manual if you are responsible for designing, installing, programming, or troubleshooting control systems that use MicroLogix 1400 controllers.

You should have a basic understanding of electrical circuitry and familiarity with relay logic. If you do not, obtain the proper training before using this product.

Purpose of this Manual

This manual is a reference guide for MicroLogix 1400 controllers and expansion I/O. It describes the procedures you use to install, wire, and troubleshoot your controller. This manual:

- explains how to install and wire your controllers
- gives you an overview of the MicroLogix 1400 controller system

Refer to publication [1766-RM001](#), MicroLogix™ 1400 Programmable Controllers Instruction Set Reference Manual for the MicroLogix 1400 instruction set and for application examples to show the instruction set in use. Refer to your RSLogix 500®/RSLogix™ Micro programming software user documentation for more information on programming your MicroLogix 1400 controller.

Related Documentation

The following documents contain additional information concerning Rockwell Automation products. To obtain a copy, contact your local Rockwell Automation office or distributor.

Resource	Description
MicroLogix 1400 Programmable Controllers Instruction Set Reference Manual 1766-RM001	Information on the MicroLogix 1400 Controllers instruction set.
MicroLogix 1400 Programmable Controllers Installation Instructions 1766-IN001	Information on mounting and wiring the MicroLogix 1400 Controllers, including a mounting template for easy installation.
Advanced Interface Converter (AIC+) User Manual 1761-UM004	A description on how to install and connect an AIC+. This manual also contains information on network wiring.
DeviceNet Interface User Manual 1761-UM005	Information on how to install, configure, and commission a DNI.
DF1 Protocol and Command Set Reference Manual 1770-6.5.16	Information on DF1 open protocol.
Modbus Protocol Specifications Available from www.modbus.org	Information about the Modbus protocol.
Distributed Network Protocol(DNP3) Specifications Available from www.dnp.org	Information about the Distributed Network Protocol.
Allen-Bradley® Programmable Controller Grounding and Wiring Guidelines 1770-4.1	In-depth information on grounding and wiring Allen-Bradley programmable controllers.
Application Considerations for Solid-State Controls SGI-1.1	A description of important differences between solid-state programmable controller products and hard-wired electromechanical devices.
National Electrical Code - Published by the National Fire Protection Association of Boston, MA.	An article on wire sizes and types for grounding electrical equipment.
Allen-Bradley Publication Index SD499	A complete listing of current documentation, including ordering instructions. Also indicates whether the documents are available on CD-ROM or in multi-languages.
Allen-Bradley Industrial Automation Glossary AG-7.1	A glossary of industrial automation terms and abbreviations.

Common Techniques Used in this Manual

The following conventions are used throughout this manual:

- Bulleted lists such as this one provide information, not procedural steps.
- Numbered lists provide sequential steps or hierarchical information.
- *Italic* type is used for emphasis.

Hardware Overview

Hardware Features

The Bulletin 1766, MicroLogix 1400 programmable controller contains a power supply, input and output circuits, a processor, an isolated combination RS-232/485 communication port, an Ethernet port, and a non-isolated RS-232 communication port. Each controller supports 32 discrete I/O points (20 digital inputs, 12 discrete outputs) and 6 analog I/O points (4 analog inputs and 2 analog outputs: 1766-L32BWAA, 1766-AWAA, and 1766-BXBA only).

The hardware features of the controller are shown below.

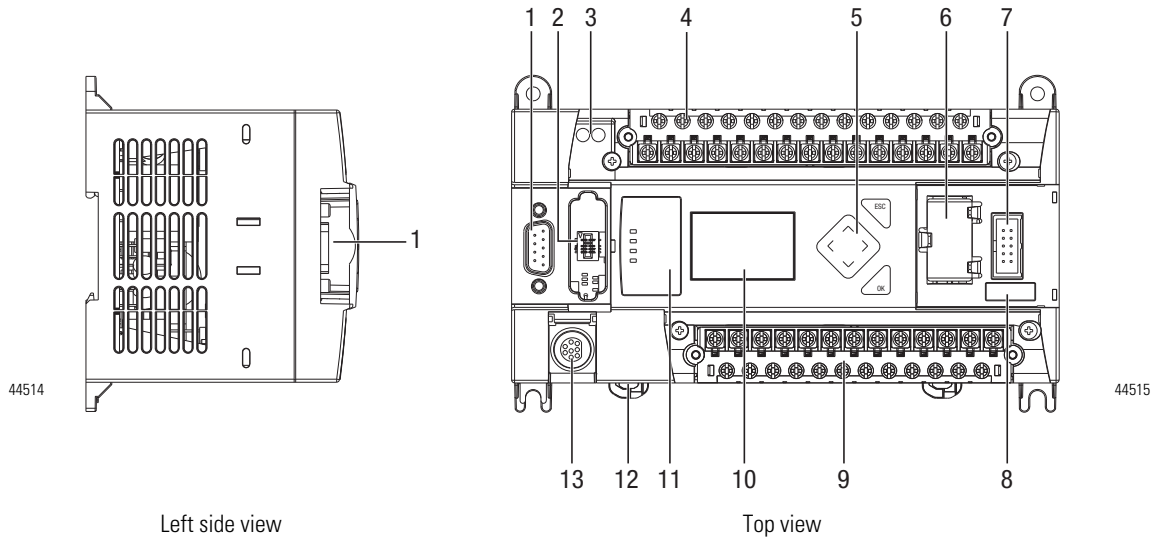

	Description
1	Comm port 2 - 9-pin D-Shell RS-232C connector
2	Memory module (refer to MicroLogix 1400 Memory Module Installation Instructions, publication 1766-IN010A for instructions on installing the memory module).
3	User 24V (for 1766-BWA and 1766-BWAA only)
4	Input terminal block
5	LCD Display Keypad (ESC, OK, Up, Down, Left, Right)
6	Battery compartment
7	1762 expansion bus connector
8	Battery connector
9	Output terminal block
10	LCD Display

	Description
11	Indicator LED panel
12	Comm port 1 - RJ45 connector
13	Comm port 0 - 8-pin mini DIN RS-232C/RS-485 connector

Controller Input and Output Description

Catalog Number	Description				Comm. Ports
	Input Power	User Power	Embedded Discrete I/O	Embedded Analog I/O	
1766-L32BWA	100/240V AC	24V DC	12 Fast 24V DC Inputs 8 Normal 24V DC Inputs 12 Relay Outputs	None	1 RS232/RS485 ⁽¹⁾ 1 Ethernet 1 RS232 ⁽²⁾
1766-L32AWA		None	20 120V AC Inputs 12 Relay Outputs		
1766-L32BXB	24V DC	12 Fast 24V DC Inputs 8 Normal 24V DC Inputs 6 Relay Outputs 3 Fast DC Outputs 3 Normal DC Outputs			
1766-L32BWAA	100/240V AC	24V DC	12 Fast 24V DC Inputs 8 Normal 24V DC Inputs 12 Relay Outputs	4 Voltage Inputs 2 Voltage Outputs	
1766-L32AWAA		None	20 120V AC Inputs 12 Relay Outputs		
1766-L32BXBA	24V DC	12 Fast 24V DC Inputs 8 Normal 24V DC Inputs 6 Relay Outputs 3 Fast DC Outputs 3 Normal DC Outputs			

⁽¹⁾ Isolated RS-232/RS-485 combo port.

⁽²⁾ Non-isolated RS-232. Standard D-sub connector

Component Descriptions

MicroLogix 1400 Memory Module and Built-in Real-Time Clock

The controller has a built-in real-time clock to provide a reference for applications that need time-based control.

The controller is shipped with a memory module port cover in place. You can order a memory module, 1766-MM1, as an accessory. The memory module provides optional backup of your user program and data, and is a means to transport your programs between controllers.

The program and data in your MicroLogix 1400 is non-volatile and is stored when the power is lost to the controller. The memory module provides additional backup that can be stored separately. The memory module does not increase the available memory of the controller.

Figure 1 - 1766-MM1 Memory Module

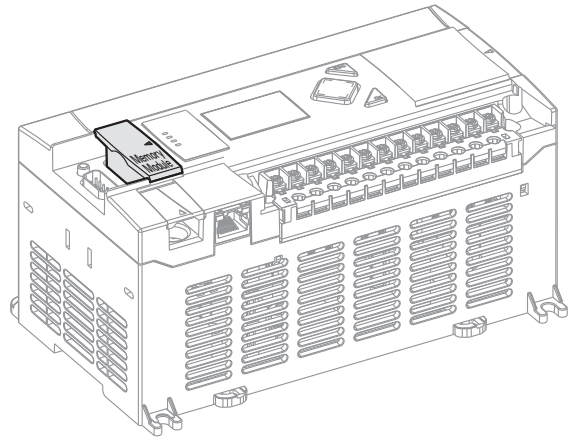

44536

1762 Expansion I/O

1762 expansion I/O can be connected to the MicroLogix 1400 controller, as shown below.

TIP A maximum of seven I/O modules, in *any* combination, can be connected to a controller. See Appendix H to determine how much heat a certain combination generates.

Figure 2 - 1762 Expansion I/O

1762 Expansion I/O

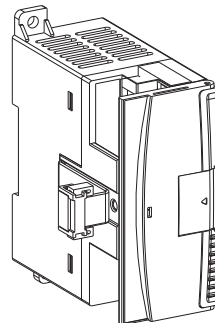

44581

1762 Expansion I/O Connected to MicroLogix 1400 Controller

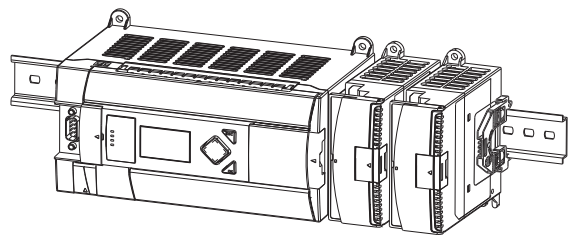

44563

Expansion I/O

Catalog Number	Description
Digital	
1762-IA8	8-Point 120V AC Input Module
1762-IQ8	8-Point Sink/Source 24V DC Input Module
1762-IQ16	16-Point Sink/Source 24V DC Input Module
1762-IQ32T	32-Point Sink/Source 24V DC Input Module
1762-OA8	8-Point 120/240V AC Triac Output Module
1762-OB8	8-Point Sourcing 24V DC Output Module

Expansion I/O

Catalog Number	Description
1762-OB16	16-Point Sourcing 24V DC Output Module
1762-OB32T	32-Point Sourcing 24V DC Output Module
1762-OV32T	32-Point Sinking 24V DC Output Module
1762-OW8	8-Point AC/DC Relay Output Module
1762-OW16	16-Point AC/DC Relay Output Module
1762-OX6I	6-Point Isolated AC/DC Relay Output Module
1762-IQ8OW6	8-Point Sink/Source 24V DC Input and 6-Point AC/DC Relay Output Module
Analog	
1762-IF4	4-Channel Voltage/Current Analog Input Module
1762-OF4	4-Channel Voltage/Current Analog Output Module
1762-IF2OF2	Combination 2-Channel Input 2-Channel Output Voltage/Current Analog Module
Temperature	
1762-IR4	4-Channel RTD/Resistance Input Module
1762-IT4	4-Channel Thermocouple/mV Input Module

Communication Cables

Use only the following communication cables with the MicroLogix 1400 controllers. These cables are required for Class I Div. 2 applications.

- 1761-CBL-AM00 Series C or later
- 1761-CBL-AP00 Series C or later
- 1761-CBL-PM02 Series C or later
- 1761-CBL-HM02 Series C or later
- 2707-NC9 Series C or later
- 1763-NC01 Series A or later
- 1747-CP3 Series A or later

**ATTENTION: UNSUPPORTED CONNECTION**

Do not connect a MicroLogix 1400 controller to another MicroLogix family controller such as MicroLogix 1000, MicroLogix 1200, MicroLogix 1500, or the network port of a 1747-DPS1 Port Splitter using a 1761-CBL-AM00 (8-pin mini-DIN to 8-pin mini-DIN) cable or equivalent.

This type of connection will cause damage to the RS-232/485 communication port (Channel 0) of the MicroLogix 1400 and/or the controller itself. The communication pins used for RS-485 communications on the MicroLogix 1400 are alternately used for 24V power on the other MicroLogix controllers and the network port of the 1747-DPS1 Port Splitter.

Programming

Programming the MicroLogix 1400 controller is done using RSLogix 500/RSLogix Micro, Revision 8.10.00 or later for Series A controllers and 8.30.00 or later for Series B and Series C controllers. Communication cables for programming are available separately from the controller and software.

Firmware Revision History

Features are added to the controllers through firmware upgrades. Use the listing below to be sure that your controller's firmware is at the level you need. Firmware upgrades are not required, except to allow you access to the new features.

MicroLogix 1400

Catalog Number	OS ⁽¹⁾ Series Letter	OS Revision Letter	OS Firmware Release No.	Release Date	Enhancement
1766-L16AWA 1766-L16BWA 1766-L16BBB	A	A	FRN1	August 2005	Initial product release.
	A	B	FRN2	October 2005	According to the SRAM component, MicroLogix 1400 may cause Hard-fault at the start of the Operating System in the very high temperature environment. Corrected.
	A	C	FRN3	February 2006	Added Data file write feature through web server.

MicroLogix 1400

Catalog Number	OS ⁽¹⁾ Series Letter	OS Revision Letter	OS Firmware Release No.	Release Date	Enhancement
1766-L16AWA 1766-L16BWA 1766-L16BBB	B	A	FRN4	February 2007	<ul style="list-style-type: none"> •Direct connection to RS485 Network for DF1 half-duplex Master driver. •Direct connection to RS485 Network for DF1 half-duplex Slave driver. •Direct connection to RS485 Network for ASCII driver. •Selectable Stop/Data Bits for Modbus Master RTU driver. •Selectable Stop/Data Bits for Modbus Slave RTU driver. •Selectable Stop/Data Bits for ASCII driver. •Settable Inactivity Timeout feature for Ethernet driver. •Unsolicited Ethernet messaging to RSLinx[®] OPC topic. •CIP Generic messaging through the Ethernet port. •Unconnected Ethernet/IP protocol for Ethernet driver. •IP conflict detection mechanism. •E-mail feature. •Ethernet MSG break bit. •DNS functionality when E-mail feature is used. •Change IP Address using Ethernet MSG instruction. •ST file type for all PCCC commands. •HSC (High-Speed Counter) up to 40 KHz. •PTO/PWM up to 40 KHz. •2-channel Analog Input Filter. •Web View Disable for Data Files.
1766-L16AWA 1766-L16BWA 1766-L16BBB	B	B	FRN5	May 2007	<ul style="list-style-type: none"> •Fixed defect for CIP Messaging Error when CIP service code is 4Bh or 4Ch. •Fixed defect for the Ethernet/IP List Identity reply. •Fixed defect for window size error in TCP/IP stack. •Improved system interrupt delay time.
1766-L16DWD	B	B	FRN5	May 2007	<ul style="list-style-type: none"> •Initial Product release. Supports all the features listed above for the 1766-L16AWA, 1766-L16BWA, and 1766-L16BBB controllers.

⁽¹⁾ OS = Operating System.

Communication Options

The MicroLogix 1400 controllers provide three communications ports, an isolated combination RS-232/485 communication port (Channel 0), an

Ethernet port (Channel 1) and a non-isolated RS-232 communication port (Channel 2).

The Channel 0 and Channel 2 ports on the MicroLogix 1400 can be connected to the following:

- operator interfaces, personal computers, and so on, using DF1 Full Duplex point-to-point
- a DH-485 network
- a DF1 Radio Modem network
- a DF1 half-duplex network as an RTU Master or RTU Slave
- a Modbus network as an RTU Master or RTU Slave
- an ASCII network
- an Ethernet network using the Ethernet Interface module (catalog number 1761-NET-ENI, or 1761-NET-ENIW)
- a DNP3 network as a Slave

When connecting to RS-485 network using DH-485, DF1 Half-Duplex Master/Slave, Modbus RTU Master/Slave, or DNP3 Slave protocols, the MicroLogix 1400 can be connected directly via Channel 0 without an Advanced Interface Converter, catalog number 1761-NET-AIC. The Channel 0 combo port provides both RS-232 and RS-485 isolated connections. The appropriate electrical interface is selected through your choice of communication cable. The existing MicroLogix 1761 communication cables provide an interface to the RS-232 drivers. The 1763-NC01 cable provides an interface to the RS-485 drivers.

The controller may also be connected to serial devices, such as bar code readers, weigh scales, serial printers, and other intelligent devices, using ASCII. See Default Communication Configuration on page 76 for the configuration settings for Channel 0. MicroLogix 1400 can be connected directly to RS-485 network via channel 0, using ASCII.

The MicroLogix 1400 supports EtherNet/IP communication via the Ethernet communication Channel 1. In addition, either Modbus TCP or DNP3 over IP can be enabled for Channel 1. You can connect your controller to a local area network that provides communication between various devices at 10 Mbps or 100 Mbps. This port supports CIP explicit messaging (message exchange) only. The controller cannot be used for CIP implicit messaging (real-time I/O messaging). The controller also includes an embedded web server which allows viewing of not only module information, TCP/IP configuration, and diagnostic information, but also includes the data table memory map and data table monitor screen using a standard web browser.

See [Chapter 4](#) for more information on connecting to the available communication options.

Notes:

Install Your Controller

This chapter shows you how to install your controller. The only tools you require are a flat or Phillips head screwdriver and drill. Topics include:

- agency certifications
- compliance to European Union Directives
- installation considerations
- safety considerations
- power considerations
- preventing excessive heat
- master control relay
- installing a memory module
- using the battery
- controller mounting dimensions
- controller and expansion I/O spacing
- mounting the controller
- mounting 1762 expansion I/O
- connecting 1762 expansion I/O

Agency Certifications

- UL Listed Industrial Control Equipment for use in Class I, Division 2, Hazardous Locations, Groups A, B, C, D
- C-UL Listed Industrial Control Equipment for use in Canada
- CE compliant for all applicable directives
- RCM compliant for all applicable directives
- EAC compliant for all applicable directives

Compliance to European Union Directives

This product has the CE mark and is approved for installation within the European Union and EEA regions. It has been designed and tested to meet the following directives.

EMC Directive

This product is tested to meet Council Directive 2014/30/EU Electromagnetic Compatibility (EMC) and the following standards, in whole or in part, documented in a technical construction file:

- EN 61131-2; Programmable Controllers (Clause 8, Zone A & B)
- EN 61131-2; Programmable Controllers (Clause 11)
- EN 61000-6-4
EMC - Part 6-4: Generic Standards - Emission Standard for Industrial Environments
- EN 61000-6-2
EMC - Part 6-2: Generic Standards - Immunity for Industrial Environments

This product is intended for use in an industrial environment.

Low Voltage Directive

This product is tested to meet Council Directive 2014/35/EU Low Voltage, by applying the safety requirements of EN 61131-2 Programmable Controllers, Part 2 - Equipment Requirements and Tests.

For specific information required by EN 61131-2, see the appropriate sections in this publication, as well as the following Allen-Bradley publications:

- *Industrial Automation Wiring and Grounding Guidelines for Noise Immunity*, publication 1770-4.1
- *Guidelines for Handling Lithium Batteries*, publication AG-5.4
- *Automation Systems Catalog*, publication B115

Installation Considerations

Most applications require installation in an industrial enclosure (Pollution Degree 2⁽¹⁾) to reduce the effects of electrical interference (Over Voltage Category II⁽²⁾) and environmental exposure. Locate your controller as far as possible from power lines, load lines, and other sources of electrical noise such as hard-contact switches, relays, and AC motor drives. For more information on proper grounding guidelines, see the *Industrial Automation Wiring and Grounding Guidelines* publication [1770-4.1](#).



ATTENTION: Electrostatic discharge can damage semiconductor devices inside the controller. Do not touch the connector pins or other sensitive areas.



ATTENTION: Vertical mounting of the controller is not supported due to heat build-up considerations.

⁽¹⁾ Pollution Degree 2 is an environment where normally only non-conductive pollution occurs except that occasionally temporary conductivity caused by condensation shall be expected.

⁽²⁾ Overvoltage Category II is the load level section of the electrical distribution system. At this level, transient voltages are controlled and do not exceed the impulse voltage capability of the products insulation.



ATTENTION: Be careful of metal chips when drilling mounting holes for your controller or other equipment within the enclosure or panel. Drilled fragments that fall into the controller or I/O modules could cause damage. Do not drill holes above a mounted controller if the protective debris shields are removed or the processor is installed.



WARNING: Do not place the MicroLogix 1400 Programmable Controller in direct sunlight. Prolonged exposure to direct sunlight could degrade the LCD display and have adverse effects on the controller.
The controller is not designed for outdoor use.

Safety Considerations

Safety considerations are an important element of proper system installation. Actively thinking about the safety of yourself and others, as well as the condition of your equipment, is of primary importance. We recommend reviewing the following safety considerations.

Hazardous Location Considerations

This equipment is suitable for use in Class I, Division 2, Groups A, B, C, D or non-hazardous locations only. The following WARNING statement applies to use in hazardous locations.



WARNING: EXPLOSION HAZARD

- Substitution of components may impair suitability for Class I, Division 2.
- Do not replace components or disconnect equipment unless power has been switched off.
- Do not connect or disconnect components unless power has been switched off.
- This product must be installed in an enclosure. All cables connected to the product must remain in the enclosure or be protected by conduit or other means.
- All wiring must comply with N.E.C. article 501-10(b) and/or in accordance with Section 18-1J2 of the Canadian Electrical Code, and in accordance with the authority having jurisdiction.
- For applicable equipment (for example, relay modules), exposure to some chemicals may degrade the sealing properties of the materials used in these devices:

• Relays, epoxy

It is recommended that you periodically inspect these devices for any degradation of properties and replace the module if degradation is found.

Use only the following communication cables in Class I, Division 2 hazardous locations.

Environment Classification	Communication Cables
Class I, Division 2 Hazardous Environment	1761-CBL-AC00 Series C or later
	1761-CBL-AM00 Series C or later
	1761-CBL-AP00 Series C or later
	1761-CBL-PM02 Series C or later
	1761-CBL-HM02 Series C or later
	2707-NC9 Series C or later
	1763-NC01 Series A or later
	1747-CP3 Series

Disconnecting Main Power



WARNING: Explosion Hazard

Do not replace components, connect equipment, or disconnect equipment unless power has been switched off.

The main power disconnect switch should be located where operators and maintenance personnel have quick and easy access to it. In addition to disconnecting electrical power, all other sources of power (pneumatic and hydraulic) should be de-energized before working on a machine or process controlled by a controller.

Safety Circuits



WARNING: Explosion Hazard

Do not connect or disconnect connectors while circuit is live.

Circuits installed on the machine for safety reasons, like overtravel limit switches, stop push buttons, and interlocks, should always be hard-wired directly to the master control relay. These devices must be wired in series so that when any one device opens, the master control relay is de-energized, thereby removing power to the machine. Never alter these circuits to defeat their function. Serious injury or machine damage could result.

Power Distribution

There are some points about power distribution that you should know:

- The master control relay must be able to inhibit all machine motion by removing power to the machine I/O devices when the relay is de-energized. It is recommended that the controller remain powered even when the master control relay is de-energized.
- If you are using a DC power supply, interrupt the load side rather than the AC line power. This avoids the additional delay of power supply turn-off. The DC power supply should be powered directly from the fused secondary of the transformer. Power to the DC input and output circuits should be connected through a set of master control relay contacts.

Periodic Tests of Master Control Relay Circuit

Any part can fail, including the switches in a master control relay circuit. The failure of one of these switches would most likely cause an open circuit, which would be a safe power-off failure. However, if one of these switches shorts out, it no longer provides any safety protection. These switches should be tested periodically to assure they will stop machine motion when needed.

Power Considerations

The following explains power considerations for the micro controllers.

Isolation Transformers

You may want to use an isolation transformer in the AC line to the controller. This type of transformer provides isolation from your power distribution system to reduce the electrical noise that enters the controller and is often used as a step-down transformer to reduce line voltage. Any transformer used with the controller must have a sufficient power rating for its load. The power rating is expressed in volt-amperes (VA).

Power Supply Inrush

During power-up, the MicroLogix 1400 power supply allows a brief inrush current to charge internal capacitors. Many power lines and control transformers can supply inrush current for a brief time. If the power source cannot supply this inrush current, the source voltage may sag momentarily.

The only effect of limited inrush current and voltage sag on the MicroLogix 1400 is that the power supply capacitors charge more slowly. However, the effect of a

voltage sag on other equipment should be considered. For example, a deep voltage sag may reset a computer connected to the same power source. The following considerations determine whether the power source must be required to supply high inrush current:

- The power-up sequence of devices in a system.
- The amount of the power source voltage sag if the inrush current cannot be supplied.
- The effect of voltage sag on other equipment in the system.

If the entire system is powered-up at the same time, a brief sag in the power source voltage typically will not affect any equipment.

Loss of Power Source

The power supply is designed to withstand brief power losses without affecting the operation of the system. The time the system is operational during power loss is called program scan hold-up time after loss of power. The duration of the power supply hold-up time depends on the type and state of the I/O, but is typically between 10 milliseconds and 3 seconds. When the duration of power loss reaches this limit, the power supply signals the processor that it can no longer provide adequate DC power to the system. This is referred to as a power supply shutdown. The processor then performs an orderly shutdown of the controller.

Input States on Power Down

The power supply hold-up time as described above is generally longer than the turn-on and turn-off times of the inputs. Because of this, the input state change from “On” to “Off” that occurs when power is removed may be recorded by the processor before the power supply shuts down the system. Understanding this concept is important. The user program should be written to take this effect into account.

Other Types of Line Conditions

Occasionally the power source to the system can be temporarily interrupted. It is also possible that the voltage level may drop substantially below the normal line voltage range for a period of time. Both of these conditions are considered to be a loss of power for the system.

Preventing Excessive Heat

For most applications, normal convective cooling keeps the controller within the specified operating range. Ensure that the specified temperature range is maintained. Proper spacing of components within an enclosure is usually sufficient for heat dissipation.

In some applications, a substantial amount of heat is produced by other equipment inside or outside the enclosure. In this case, place blower fans inside the enclosure to assist in air circulation and to reduce “hot spots” near the controller.

Additional cooling provisions might be necessary when high ambient temperatures are encountered.

TIP Do not bring in unfiltered outside air. Place the controller in an enclosure to protect it from a corrosive atmosphere. Harmful contaminants or dirt could cause improper operation or damage to components. In extreme cases, you may need to use air conditioning to protect against heat build-up within the enclosure.

Master Control Relay

A hard-wired master control relay (MCR) provides a reliable means for emergency machine shutdown. Since the master control relay allows the placement of several emergency-stop switches in different locations, its installation is important from a safety standpoint. Overtravel limit switches or mushroom-head push buttons are wired in series so that when any of them opens, the master control relay is de-energized. This removes power to input and output device circuits. Refer to the figures on pages 31 and 32.



ATTENTION: Never alter these circuits to defeat their function since serious injury and/or machine damage could result.

TIP If you are using an external DC power supply, interrupt the DC output side rather than the AC line side of the supply to avoid the additional delay of power supply turn-off.

The AC line of the DC output power supply should be fused.

Connect a set of master control relays in series with the DC power supplying the input and output circuits.

Place the main power disconnect switch where operators and maintenance personnel have quick and easy access to it. If you mount a disconnect switch inside the controller enclosure, place the switch operating handle on the outside of the enclosure, so that you can disconnect power without opening the enclosure.

Whenever any of the emergency-stop switches are opened, power to input and output devices should be removed.

When you use the master control relay to remove power from the external I/O circuits, power continues to be provided to the controller's power supply so that diagnostic indicators on the processor can still be observed.

The master control relay is not a substitute for a disconnect to the controller. It is intended for any situation where the operator must quickly de-energize I/O devices only. When inspecting or installing terminal connections, replacing output fuses, or working on equipment within the enclosure, use the disconnect to shut off power to the rest of the system.

TIP Do not control the master control relay with the controller. Provide the operator with the safety of a direct connection between an emergency-stop switch and the master control relay.

Using Emergency-Stop Switches

When using emergency-stop switches, adhere to the following points:

- Do not program emergency-stop switches in the controller program. Any emergency-stop switch should turn off all machine power by turning off the master control relay.
- Observe all applicable local codes concerning the placement and labeling of emergency-stop switches.
- Install emergency-stop switches and the master control relay in your system. Make certain that relay contacts have a sufficient rating for your application. Emergency-stop switches must be easy to reach.
- In the following illustration, input and output circuits are shown with MCR protection. However, in most applications, only output circuits require MCR protection.

The following illustrations show the Master Control Relay wired in a grounded system.

TIP In most applications input circuits do not require MCR protection; however, if you need to remove power from all field devices, you must include MCR contacts in series with input power wiring.

Schematic (Using IEC Symbols)

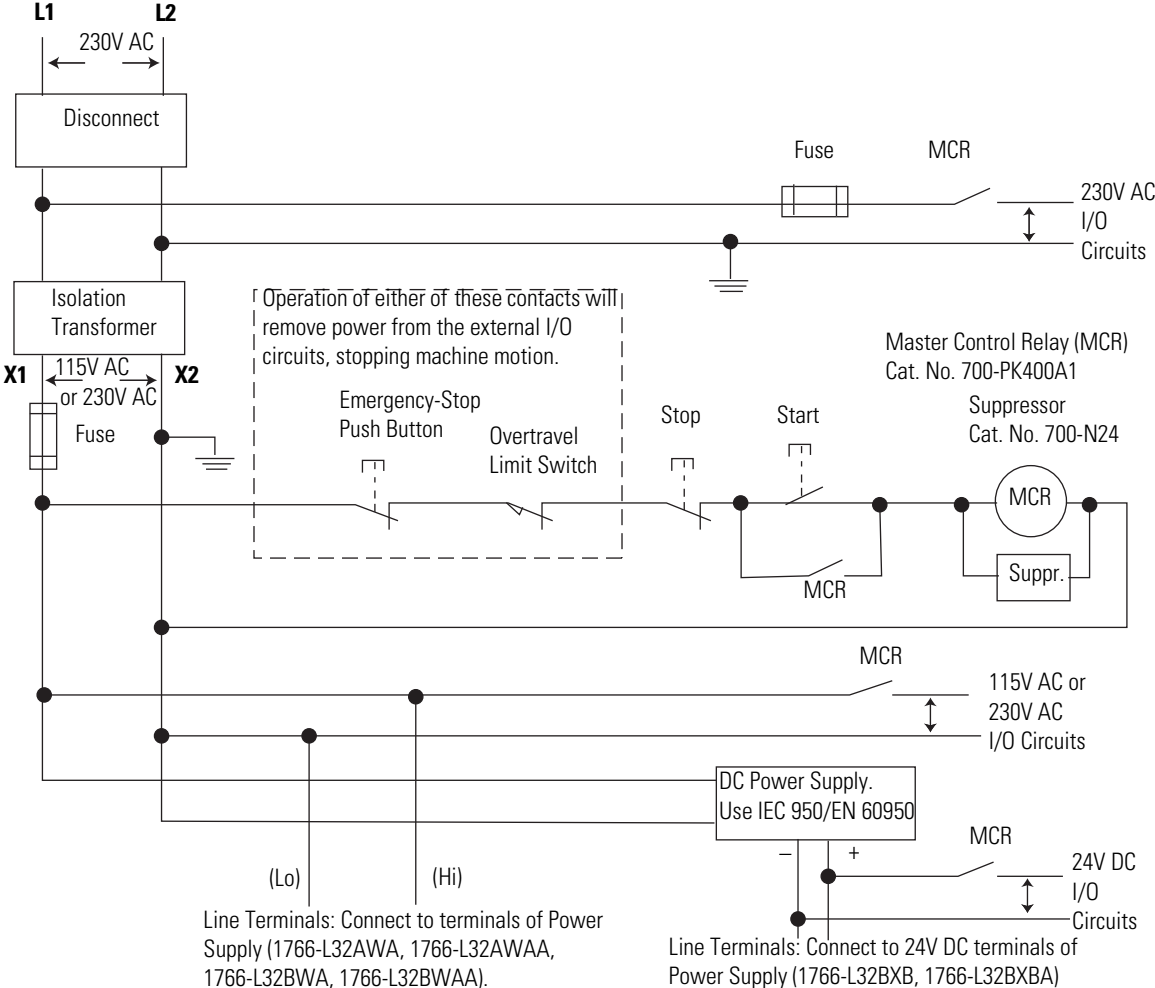

44564

Schematic (Using ANSI/CSA Symbols)

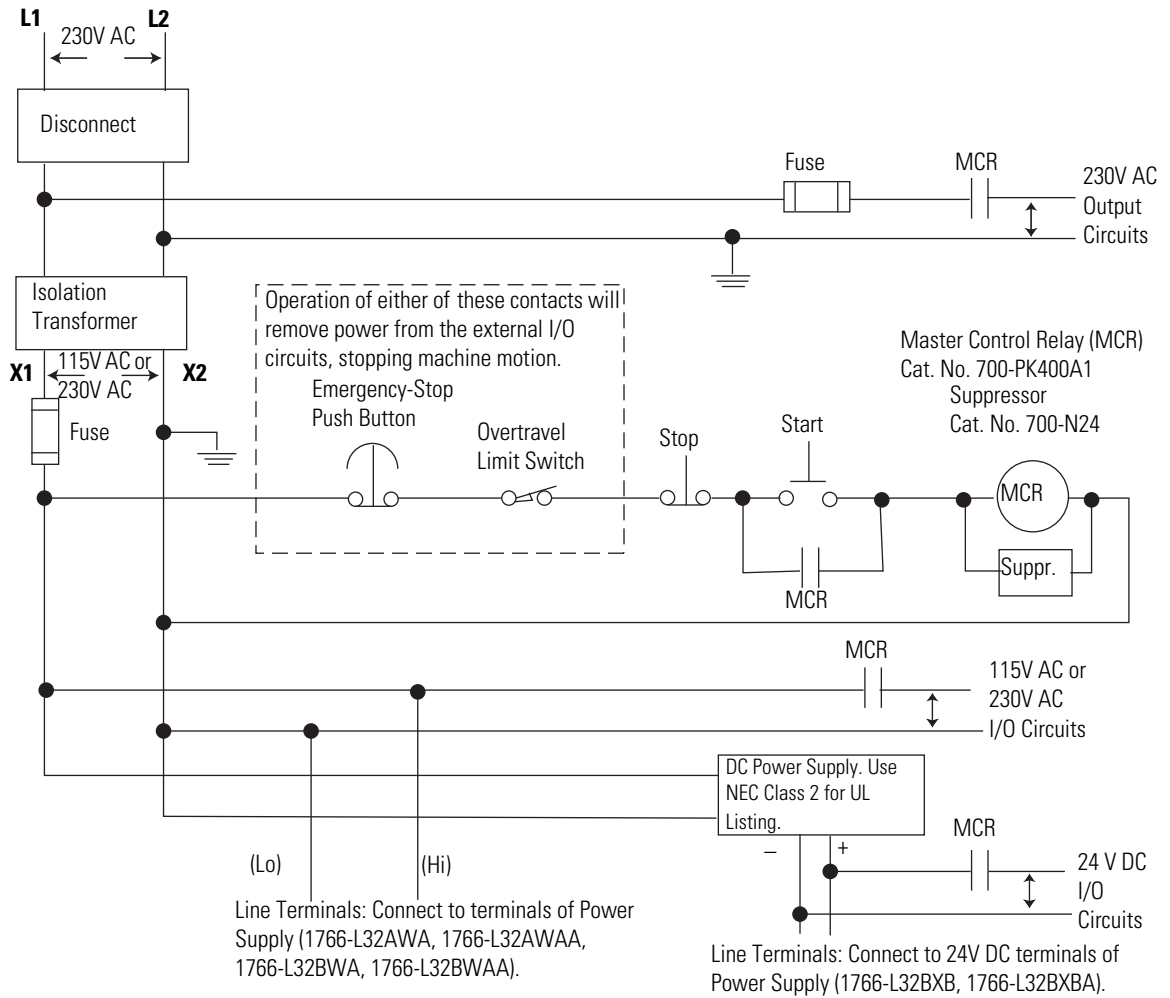

44565

Installing a Memory Module

1. Remove the memory module port cover.

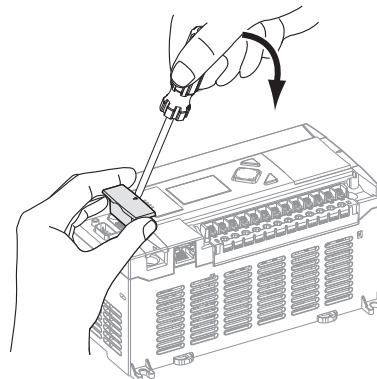

44534

- Align the connector on the memory module with the connector pins on the controller.

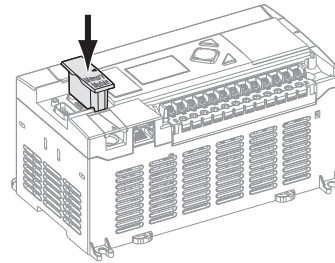

44535

- Firmly seat the memory module into the controller.

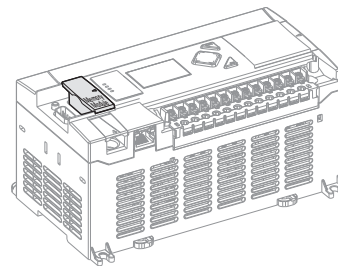

44536

- Use a screwdriver as in step 1 to remove the memory module in the future.

Using the Battery

The MicroLogix 1400 controller is equipped with a replaceable battery (catalog number 1747-BA). The Battery Low indicator on the LCD display of the controller shows the status of the replaceable battery. When the battery is low, the indicator is set (displayed as a solid rectangle). This means that either the battery wire connector is disconnected, or the battery may fail within 2 weeks if it is connected.

IMPORTANT

The MicroLogix 1400 controller ships with the battery wire connector connected.

Ensure that the battery wire connector is inserted into the connector port if your application needs battery power. For example, when using a real-time clock (RTC).

Replacing the battery when the controller is powered down will lose all user application memory. Replace the battery when the controller is powered on.

Refer to the [SLC™ 500 Lithium Battery Installation Instructions, publication 1747-IN515](#), for more information on installation, handling, usage, storage, and disposal of the battery.

See RTC Battery Operation on page 172, for more information on the use of the battery in relation with RTC.



WARNING: When you connect or disconnect the battery an electrical arc can occur. This could cause an explosion in hazardous location installations. Be sure that the area is nonhazardous before proceeding.
For Safety information on the handling of lithium batteries, including handling and disposal of leaking batteries, see [Guidelines for Handling Lithium Batteries, publication AG 5-4](#).

IMPORTANT When the controller's Battery Low indicator is set (displayed as a solid rectangle) with the battery wire connector connected, you should install a new battery immediately.

Connecting the Battery Wire Connector

Follow the procedure below to connect the battery wire connector to the battery connector.

1. Insert the replaceable battery wire connector into the controller's battery connector.
2. Secure the battery connector wires so that it does not block the 1762 I/O expansion bus connector as shown below.

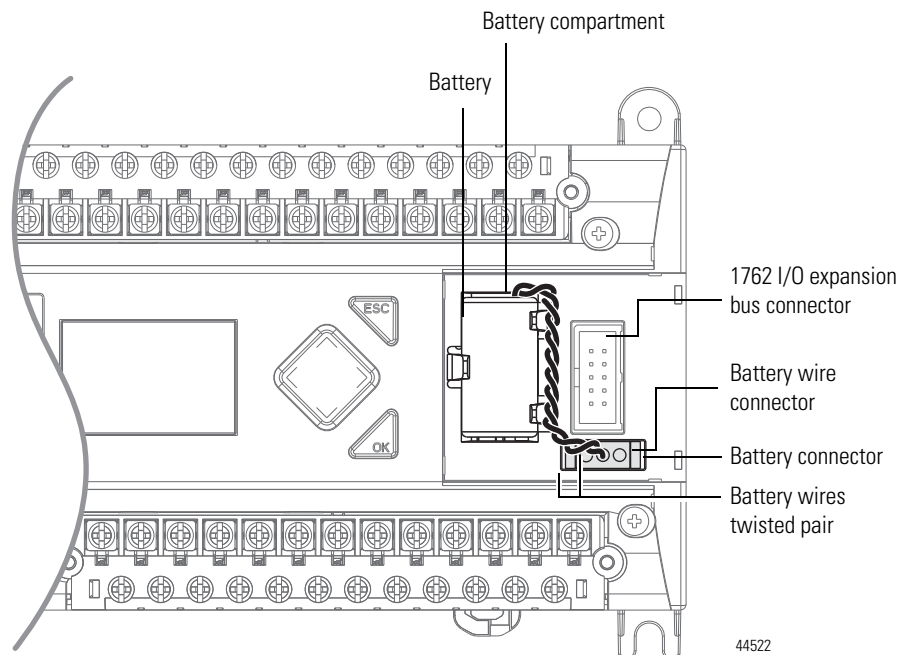

Controller Mounting Dimensions

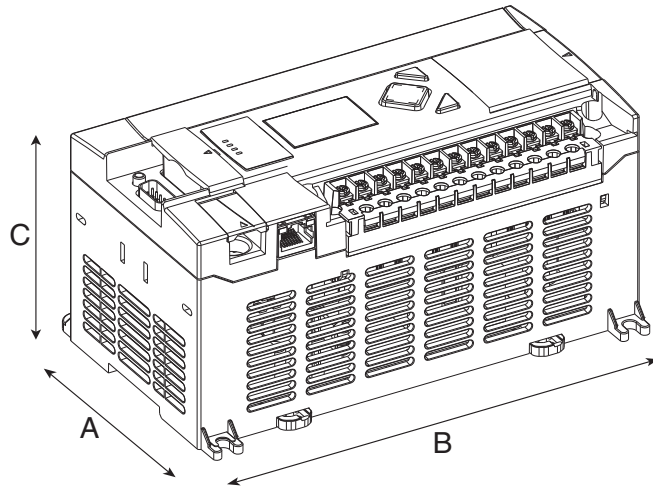

44516

1766-L32BWA, 1766-L32AWA, 1766-L32BXB, 1766-L32BWAA,
1766-L32AWAA, 1766-L32BXBA

Dimension	Measurement
A	90 mm (3.5 in.)
B	180 mm (7.087 in.)
C	87 mm (3.43 in.)

Controller and Expansion I/O Spacing

The controller mounts horizontally, with the expansion I/O extending to the right of the controller. Allow 50 mm (2 in.) of space on all sides of the controller system for adequate ventilation. Maintain spacing from enclosure walls, wireways, adjacent equipment, and so on, as shown below.

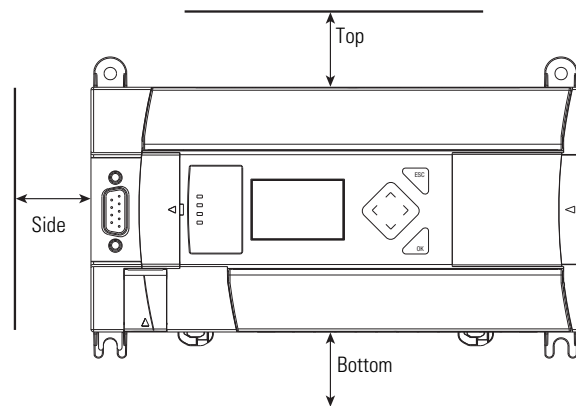

44517

Mounting the Controller

MicroLogix 1400 controllers are suitable for use in an industrial environment when installed in accordance with these instructions. Specifically, this equipment is intended for use in clean, dry environments (Pollution degree 2⁽¹⁾) and to circuits not exceeding Over Voltage Category II⁽²⁾ (IEC 60664-1).⁽³⁾



ATTENTION: Do not remove the protective debris shield until after the controller and all other equipment in the panel near the controller are mounted and wiring is complete. Once wiring is complete, remove protective debris shield. Failure to remove shield before operating can cause overheating.

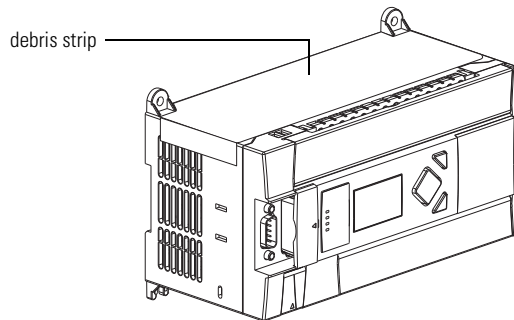

ATTENTION: Electrostatic discharge can damage semiconductor devices inside the controller. Do not touch the connector pins or other sensitive areas.

TIP

For environments with greater vibration and shock concerns, use the panel mounting method described on page 38, rather than DIN rail mounting.

- ⁽¹⁾ Pollution Degree 2 is an environment where, normally, only non-conductive pollution occurs except that occasionally a temporary conductivity caused by condensation shall be expected.
- ⁽²⁾ Over Voltage Category II is the load level section of the electrical distribution system. At this level transient voltages are controlled and do not exceed the impulse voltage capability of the product's insulation.
- ⁽³⁾ Pollution Degree 2 and Over Voltage Category II are International Electrotechnical Commission (IEC) designations.

DIN Rail Mounting

The maximum extension of the latch is 14 mm (0.55 in.) in the open position. A flat-blade screwdriver is required for removal of the controller. The controller can be mounted to EN50022-35x7.5 or EN50022-35x15 DIN rails. DIN rail mounting dimensions are shown below.

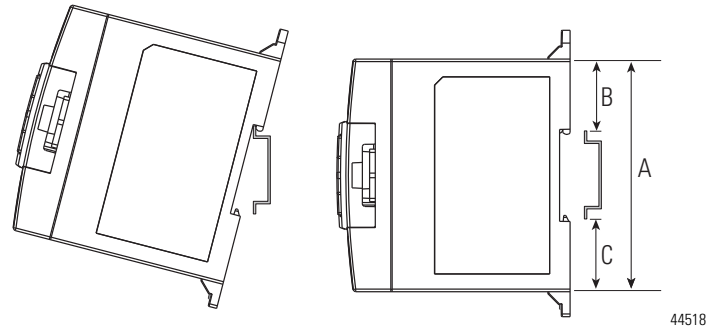

Dimension	Height
A	90 mm (3.5 in.)
B	27.5 mm (1.08 in.)
C	27.5 mm (1.08 in.)

Follow this procedure to install your controller on the DIN rail.

1. Mount your DIN rail. (Make sure that the placement of the controller on the DIN rail meets the recommended spacing requirements, see [Controller and Expansion I/O Spacing on page 35](#). Refer to the mounting template inside the back cover of this document.)
2. Close the DIN latch, if it is open.
3. Hook the top slot over the DIN rail.
4. While pressing the controller down against the top of the rail, snap the bottom of the controller into position.
5. Leave the protective debris shield attached until you are finished wiring the controller and any other devices.

To remove your controller from the DIN rail:

1. Place a flat-blade screwdriver in the DIN rail latch at the bottom of the controller.
2. Holding the controller, pry downward on the latch until the latch locks in the open position.
3. Repeat steps 1 and 2 for the second DIN rail latch.
4. Unhook the top of the DIN rail slot from the rail.

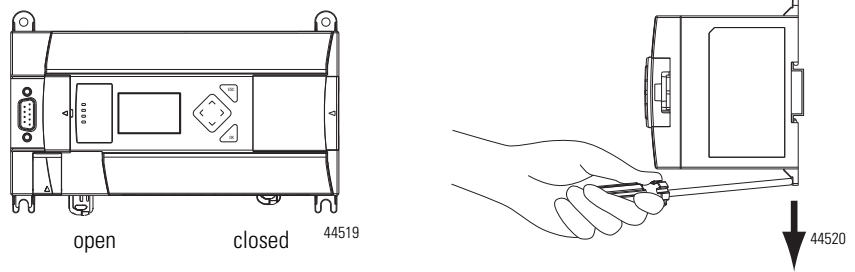

Panel Mounting

Mount to panel using #8 or M4 screws. To install your controller using mounting screws:

1. Remove the mounting template from inside the back cover of the *MicroLogix 1400 Programmable Controllers Installation Instructions*, publication [1766-IN001](#).
2. Secure the template to the mounting surface. (Make sure your controller is spaced properly. See [Controller and Expansion I/O Spacing on page 35](#).)
3. Drill holes through the template.
4. Remove the mounting template.
5. Mount the controller.
6. Leave the protective debris shield in place until you are finished wiring the controller and any other devices.

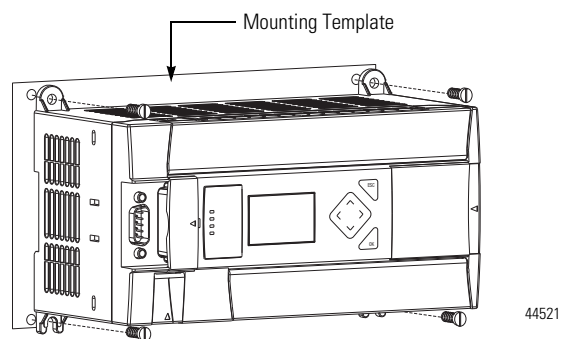

1762 Expansion I/O Dimensions

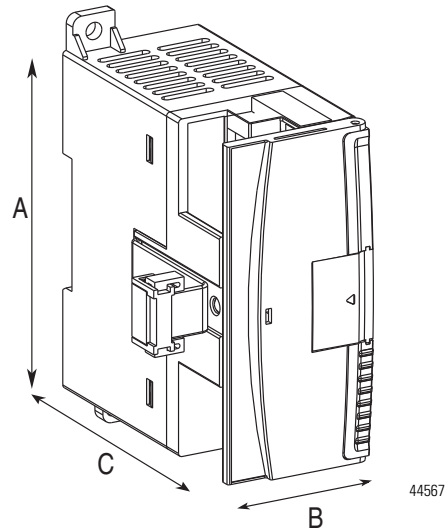

Dimension	Measurement
A	90 mm (3.5 in.)
B	40 mm (1.57 in.)
C	87 mm (3.43 in.)

Mounting 1762 Expansion I/O



ATTENTION: During panel or DIN rail mounting of all devices, be sure that all debris such as metal chips and wire stands, is kept from falling into the module. Debris that falls into the module could cause damage when the module is under power.

DIN Rail Mounting

The module can be mounted using the following DIN rails:

- 35 x 7.5 mm (EN 50 022 - 35 x 7.5), or
- 35 x 15 mm (EN 50 022 - 35 x 15).

Before mounting the module on a DIN rail, close the DIN rail latch. Press the DIN rail mounting area of the module against the DIN rail. The latch momentarily opens and locks into place.

Use DIN rail end anchors (Allen-Bradley part number 1492-EA35 or 1492-EAH35) for vibration or shock environments. The following illustration shows the location of the end anchors.

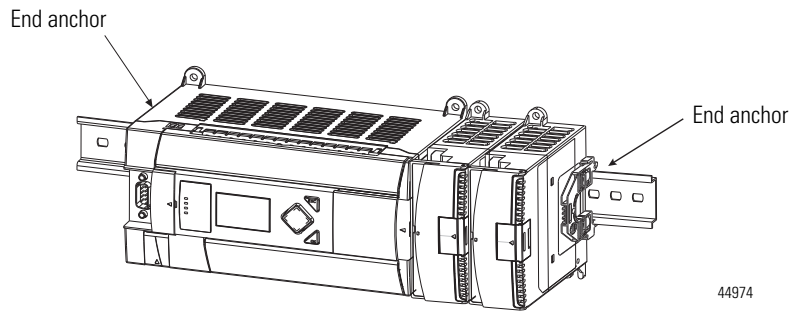

TIP 1762 expansion I/O must be mounted horizontally as illustrated.

TIP For environments with greater vibration and shock concerns, use the panel mounting method described below, instead of DIN rail mounting.

Panel Mounting

Use the dimensional template shown below to mount the module. The preferred mounting method is to use two M4 or #8 panhead screws per module. Mounting screws are required on every module.

For more than 2 modules: (number of modules - 1) x 40 mm (1.59 in.)

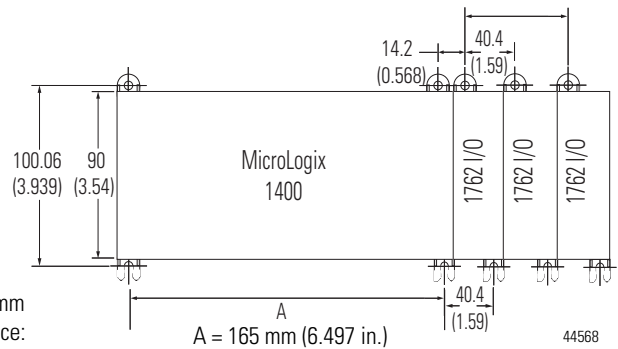

NOTE: All dimensions are in mm (inches). Hole spacing tolerance: ± 0.4 mm (0.016 in.).

44568

Connecting Expansion I/O

The expansion I/O module is attached to the controller or another I/O module by means of a flat ribbon cable *after* mounting, as shown below.

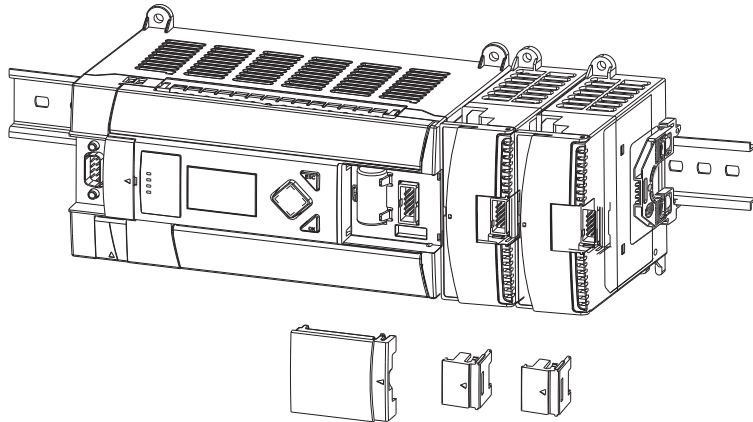

44975

TIP

Use the pull loop on the connector to disconnect modules. Do not pull on the ribbon cable.

TIP

Up to seven expansion I/O modules can be connected to a controller.



ATTENTION: Remove power before removing or inserting an I/O module. When you remove or insert a module with power applied, an electrical arc may occur. An electrical arc can cause personal injury or property damage by:

- sending an erroneous signal to your system's field devices, causing the controller to fault
- causing an explosion in a hazardous environment

Electrical arcing causes excessive wear to contacts on both the module and its mating connector. Worn contacts may create electrical resistance, reducing product reliability.

**WARNING: EXPLOSION HAZARD**

In Class I, Division 2 applications, the bus connector must be fully seated and the bus connector cover must be snapped in place.

In Class I, Division 2 applications, all modules must be mounted in direct contact with each other as shown on page 41. If DIN rail mounting is used, an end stop must be installed ahead of the controller and after the last 1762 I/O module.

Notes:

Wire Your Controller

This chapter describes how to wire your controller and expansion I/O. Topics include:

- wire requirements
- using surge suppressors
- grounding the controller
- wiring diagrams
- sinking and sourcing wiring diagrams
- controller I/O wiring
- wiring your analog channels
- expansion I/O wiring

Wiring Requirements

Wiring Recommendation



ATTENTION: Before you install and wire any device, disconnect power to the controller system.



ATTENTION: Calculate the maximum possible current in each power and common wire. Observe all electrical codes dictating the maximum current allowable for each wire size. Current above the maximum ratings may cause wiring to overheat, which can cause damage.

United States Only: If the controller is installed within a potentially hazardous environment, all wiring must comply with the requirements stated in the National Electrical Code 501-10 (b).

- Allow for at least 50 mm. (2 in.) between I/O wiring ducts or terminal strips and the controller.
- Route incoming power to the controller by a path separate from the device wiring. Where paths must cross, their intersection should be perpendicular.

TIP

Do not run signal or communications wiring and power wiring in the same conduit. Wires with different signal characteristics should be routed by separate paths.

- Separate wiring by signal type. Bundle wiring with similar electrical characteristics together.
- Separate input wiring from output wiring.
- Label wiring to all devices in the system. Use tape, shrink-tubing, or other dependable means for labeling purposes. In addition to labeling, use colored insulation to identify wiring based on signal characteristics. For example, you may use blue for DC wiring and red for AC wiring.

Wire Requirements

Wire Type		Wire Size (2 wire maximum per terminal screw)	
		1 wire per terminal	2 wire per terminal
Solid	Cu-90°C (194°F)	#12 to #20 AWG	#16 to #20 AWG
Stranded	Cu-90°C (194°F)	#14 to #20 AWG	#18 to #20 AWG

Wiring torque = 0.56 Nm (5.0 in-lb) rated

Wire without Spade Lugs

When wiring without spade lugs, it is recommended to keep the finger-safe covers in place. Loosen the terminal screw and route the wires through the opening in the finger-safe cover. Tighten the terminal screw making sure the pressure plate secures the wire.

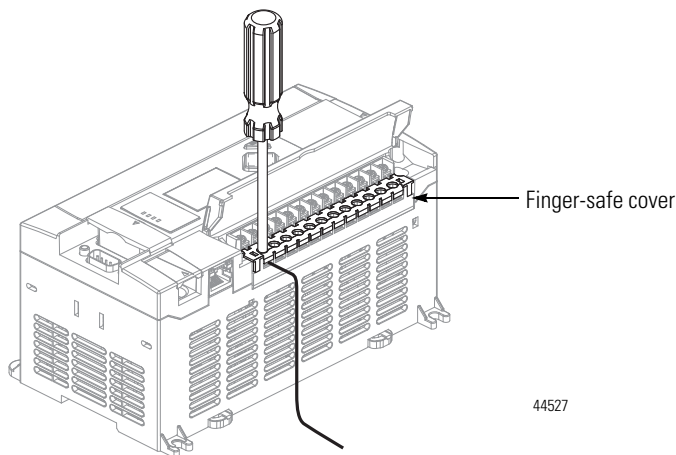

Wire with Spade Lugs

The diameter of the terminal screw head is 5.5 mm (0.220 in.). The input and output terminals of the MicroLogix 1400 controller are designed for a 6.35 mm (0.25 in.) wide spade (standard for #6 screw for up to 14 AWG) or a 4 mm (metric #4) fork terminal.

When using spade lugs, use a small, flat-blade screwdriver to pry the finger-safe cover from the terminal blocks as shown below. Then loosen the terminal screw.

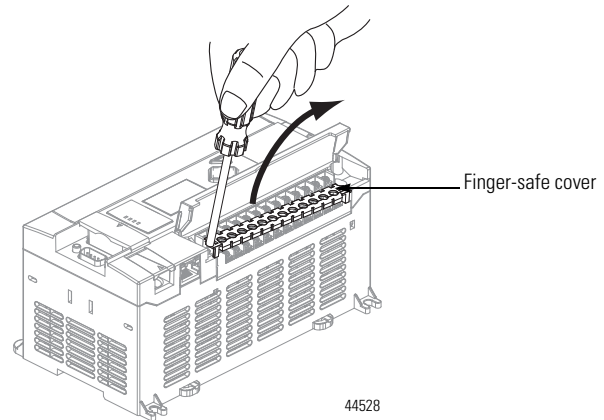

Using Surge Suppressors

Because of the potentially high current surges that occur when switching inductive load devices, such as motor starters and solenoids, the use of some type of surge suppression to protect and extend the operating life of the controllers output contacts is required. Switching inductive loads without surge suppression can *significantly* reduce the life expectancy of relay contacts. By adding a suppression device directly across the coil of an inductive device, you prolong the life of the output or relay contacts. You also reduce the effects of voltage transients and electrical noise from radiating into adjacent systems.

The following diagram shows an output with a suppression device. We recommend that you locate the suppression device as close as possible to the load device.

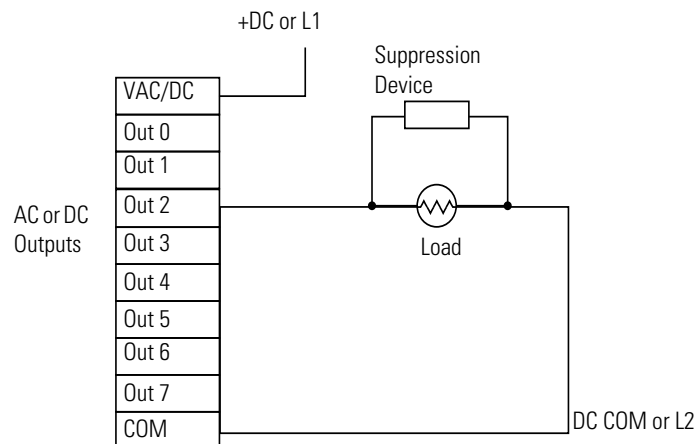

If the outputs are DC, we recommend that you use an 1N4004 diode for surge suppression, as shown below. For inductive DC load devices, a diode is suitable. A 1N4004 diode is acceptable for most applications. A surge suppressor can also be

used. See for recommended suppressors. As shown below, these surge suppression circuits connect directly across the load device.

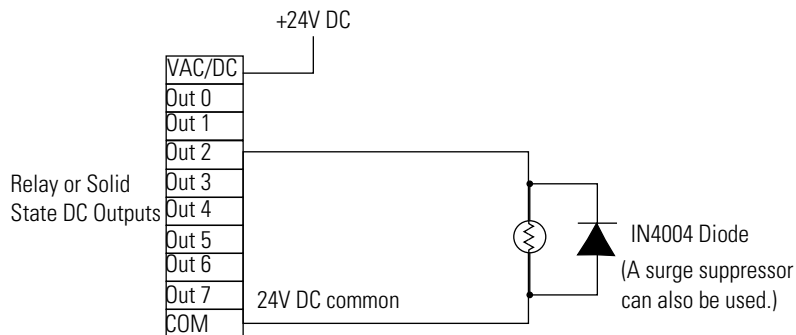

Suitable surge suppression methods for inductive AC load devices include a varistor, an RC network, or an Allen-Bradley surge suppressor, all shown below. These components must be appropriately rated to suppress the switching transient characteristic of the particular inductive device. See Recommended Surge Suppressors on page 46 for recommended suppressors.

Surge Suppression for Inductive AC Load Devices

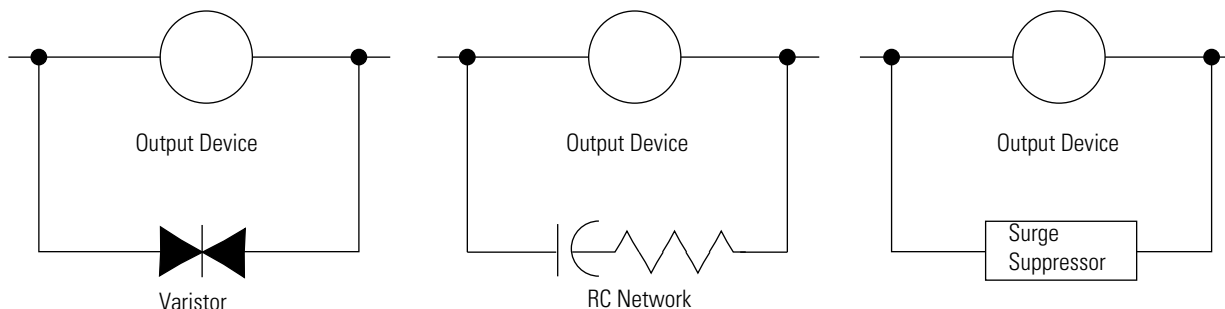

Recommended Surge Suppressors

Use the Allen-Bradley surge suppressors shown in the following table for use with relays, contactors, and starters.

Recommended Surge Suppressors

Device	Coil Voltage	Suppressor Catalog Number	Type ⁽⁴⁾
Bulletin 100/104K 700K	24...48V AC	100-KFSC50	RC
	110...280V AC	100-KFSC280	
	380...480V AC	100-KFSC480	
	12...55 V AC, 12...77V DC	100-KFSV55	MOV
	56...136 VAC, 78...180V DC	100-KFSV136	
	137...277V AC, 181...250 V DC	100-KFSV277	
	12...250V DC	100-KFSD250	Diode

Recommended Surge Suppressors

Device	Coil Voltage	Suppressor Catalog Number	Type ⁽⁴⁾
Bulletin 100C, (C09 - C97)	24...48V AC	100-FSC48 ⁽¹⁾	RC
	110...280V AC	100-FSC280 ⁽¹⁾	
	380...480V AC	100-FSC480 ⁽¹⁾	
	12...55V AC, 12...77V DC	100-FSV55 ⁽¹⁾	MOV
	56...136V AC, 78...180V DC	100-FSV136 ⁽¹⁾	
	137...277V AC, 181...250V DC	100-FSV277 ⁽¹⁾	
	278...575V AC	100-FSV575 ⁽¹⁾	
	12...250V DC	100-FSD250 ⁽¹⁾	Diode
Bulletin 509 Motor Starter Size 0 - 5	12...120V AC	599-K04	MOV
	240...264V AC	599-KA04	
Bulletin 509 Motor Starter Size 6	12...120V AC	199-FSMA1 ⁽²⁾	RC
	12...120V AC	199-GSMA1 ⁽³⁾	MOV
Bulletin 700 R/RM Relay	AC coil	Not Required	
	24...48V DC	199-FSMA9	MOV
	50...120V DC	199-FSMA10	
	130...250V DC	199-FSMA11	
Bulletin 700 Type N, P, PK or PH Relay	6...150V AC/DC	700-N24	RC
	24...48V AC/DC	199-FSMA9	MOV
	50...120V AC/DC	199-FSMA10	
	130...250V AC/DC	199-FSMA11	
	6...300V DC	199-FSMZ-1	Diode
Miscellaneous electromagnetic devices limited to 35 sealed VA	6...150V AC/DC	700-N24	RC

⁽¹⁾ Catalog numbers for screwless terminals include the string 'CR' after '100-'.
For example: Cat. No. 100-FSC48 becomes Cat. No. 100-**CR**FSC48; Cat. No. 100-FSV55 becomes 100-**CR**FSV55; and so on.

⁽²⁾ For use on the interposing relay.

⁽³⁾ For use on the contactor or starter.

⁽⁴⁾ RC Type not to be used with Triac outputs.
Varistor is not recommended for use on the relay outputs.

Grounding the Controller

In solid-state control systems, grounding and wire routing helps limit the effects of noise due to electromagnetic interference (EMI). Run the ground connection from the ground screw of the controller to the ground bus prior to connecting any devices. Use AWG #14 wire. For AC-powered controllers, this connection must be made for safety purposes.



ATTENTION: All devices connected to the RS-232/485 communication port must be referenced to controller ground, or be floating (not referenced to a potential other than ground). Failure to follow this procedure may result in property damage or personal injury.

- For 1766-L32BWA and 1766-L32BWAA controllers, the COM of the sensor supply is also connected to chassis ground internally. The 24V DC sensor power source should not be used to power output circuits. It should only be used to power input devices.
- For 1766-L32BXB and 1766-L32BXBA controllers, the VDC NEUT or common terminal of the power supply is also connected to chassis ground internally.

This product is intended to be mounted to a well grounded mounting surface such as a metal panel. Refer to the *Industrial Automation Wiring and Grounding Guidelines*, publication [1770-4.1](#), for additional information. Additional grounding connections from the mounting tab or DIN rail, if used, are not required unless the mounting surface cannot be grounded.

TIP Use all four mounting positions for panel mounting installation.

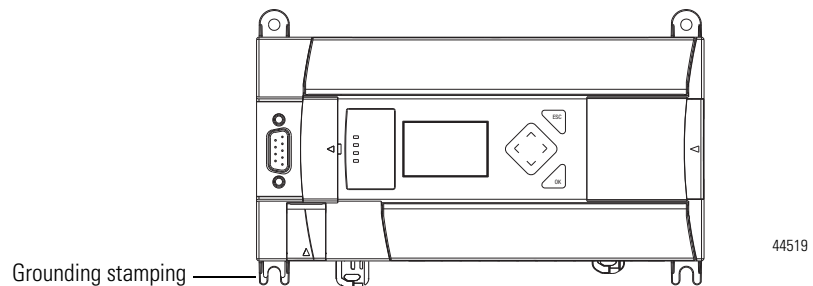

ATTENTION: Remove the protective debris strip before applying power to the controller. Failure to remove the strip may cause the controller to overheat.

Wiring Diagrams

The following illustrations show the wiring diagrams for the MicroLogix 1400 controllers. Controllers with DC inputs can be wired as either sinking or sourcing inputs. (Sinking and sourcing does not apply to AC inputs.) Refer to Sinking and Sourcing Wiring Diagrams on page 53.

The controller terminal block layouts are shown below. The shading on the labels indicates how the terminals are grouped.

TIP

This  symbol denotes a protective earth ground terminal which provides a low impedance path between electrical circuits and earth for safety purposes and provides noise immunity improvement. This connection must be made for safety purposes on AC-powered controllers.

This  symbol denotes a functional earth ground terminal which provides a low impedance path between electrical circuits and earth for non-safety purposes, such as noise immunity improvement.

Terminal Block Layouts



ATTENTION: When you connect or disconnect the Removable Terminal Block (RTB) with field side power applied, an electrical arc can occur. This could cause an explosion in hazardous location installations. Be sure that power is removed or the area is nonhazardous before proceeding.



When used in a Class I, Division 2, hazardous location, this equipment must be mounted in a suitable enclosure. All wiring must be in accordance with Class I, Division 2 wiring methods of Article 501 of the National Electrical Code and/or in accordance with Section 18-1J2 of the Canadian Electrical Code, and in accordance with the authority having jurisdiction.

Figure 3 - 1766-L32BWA/L32BWAA

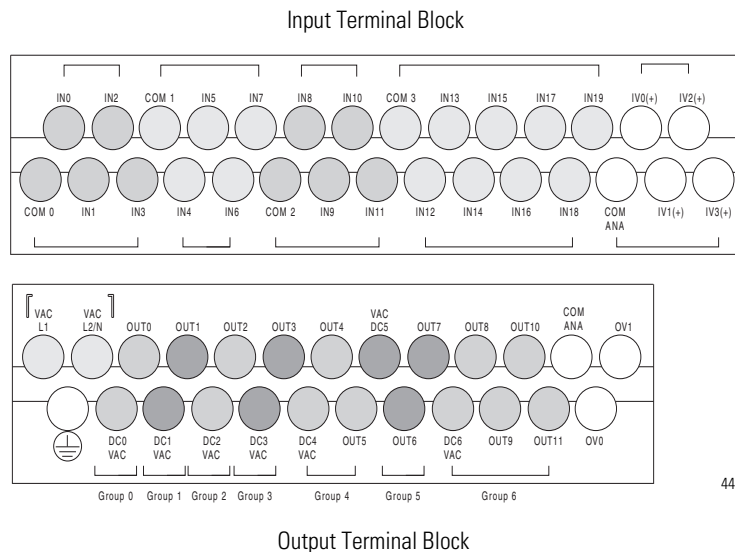



ATTENTION: The 24V DC sensor supply of the 1766-L32BWA and 1766-L32BWAA controllers should not be used to power output circuits. It should only be used to power input devices, for example, sensors and switches. See Master Control Relay on page 29 for information on MCR wiring in output circuits.

Figure 4 - 1766-L32AWA/L32AWAA

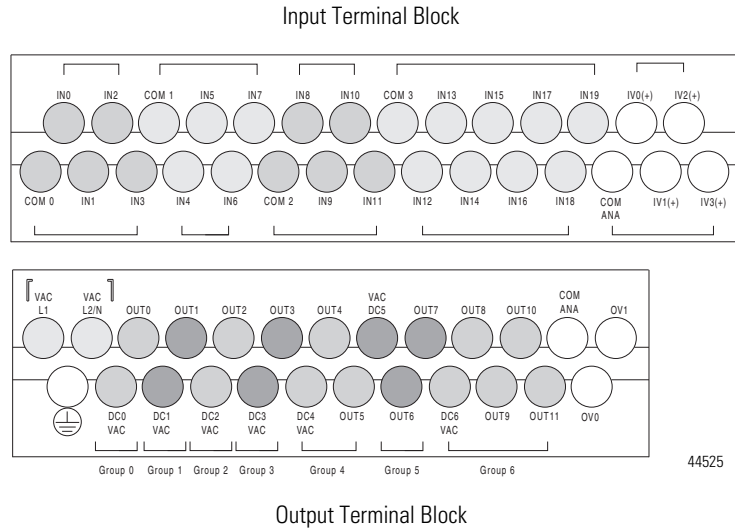
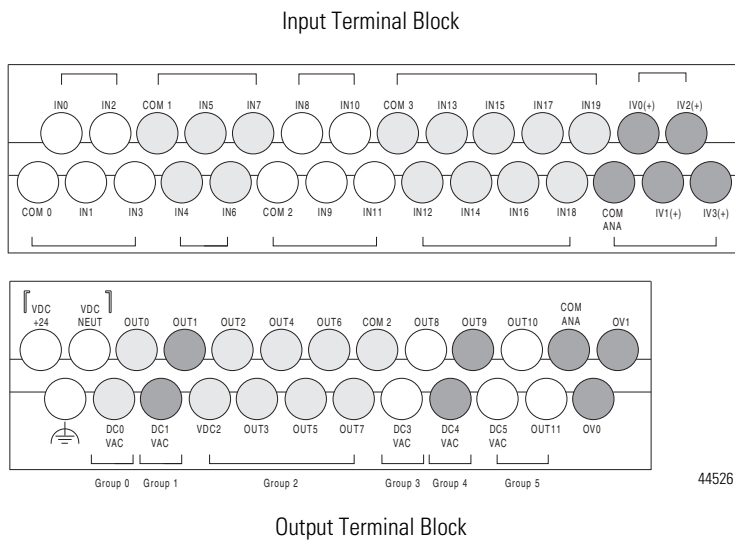

Figure 5 - 1766-L32BXB/L32BXBA



Wire Types and Sizes

Wire Type	Wire Size
-----------	-----------

Wire Types and Sizes

Solid wire	Cu-90-C (194-F)	14...22 AWG
Stranded wire	Cu-90-C (194-F)	16...22 AWG

Wiring torque = 0.791Nm (7 in-lb) rated.

Output Terminal Grouping

Controllers	Output Group	Description	Outputs Voltage Terminal	Output Terminal
1766-L32BWA 1766-L32BWAA	Group 0	Isolated relay output	VAC/DC0	OUT 0
	Group 1	Isolated relay output	VAC/DC1	OUT 1
	Group 2	Isolated relay output	VAC/DC2	OUT 2
	Group 3	Isolated relay output	VAC/DC3	OUT 3
	Group 4	Isolated relay output	VAC/DC4	OUT 4, OUT 5
	Group 5	Isolated relay output	VAC/DC5	OUT 6, OUT 7
	Group 6	Isolated relay output	VAC/DC6	OUT 8...11
1766-L32AWA 1766-L32AWAA	Group 0	Isolated relay output	VAC/DC0	OUT 0
	Group 1	Isolated relay output	VAC/DC1	OUT 1
	Group 2	Isolated relay output	VAC/DC2	OUT 2
	Group 3	Isolated relay output	VAC/DC3	OUT 3
	Group 4	Isolated relay output	VAC/DC4	OUT 4, OUT 5
	Group 5	Isolated relay output	VAC/DC5	OUT 6, OUT 7
	Group 6	Isolated relay output	VAC/DC6	OUT 8...11
1766-L32BXB 1766-L32BXBA	Group 0	Isolated relay output	VAC/DC0	OUT 0
	Group 1	Isolated relay output	VAC/DC1	OUT 1
	Group 2	FET output	VDC2/COM 2	OUT 2...7
	Group 3	Isolated relay output	VAC/DC3	OUT 8
	Group 4	Isolated relay output	VAC/DC4	OUT 9
	Group 5	Isolated relay output	VAC/DC5	OUT 10, OUT 11



WARNING: If you connect or disconnect wiring while the field-side power is on, an electrical arc can occur. This could cause an explosion in hazardous location installations. Be sure that power is removed or the area is nonhazardous before proceeding.



WARNING: The local programming terminal port is intended for temporary use only and must not be connected or disconnected unless the area is free of ignitable concentrations of flammable gases or vapors.

Terminal Groupings

Input Terminal Grouping

Controller	Inputs		
	Input Group	Common Terminal	Input Terminal
1766-L16AWA	Group 0	AC COM 0	I/0 through I/3
	Group 1	AC COM 1	I/4 through I/9
	Group 2	IA COM	IV1(+) and IV2(+)
1766-L16BWA	Group 0	DC COM 0	I/0 through I/3
	Group 1	DC COM 1	I/4 through I/9
	Group 2	IA COM	IV1(+) and IV2(+)
1766-L16BBB 1766-L16DWD	Group 0	DC COM 0	I/0 through I/3
	Group 1	DC COM 1	I/4 through I/9
	Group 2	IA COM	IV1(+) and IV2(+)

Output Terminal Grouping

Controller	Outputs		
	Output Group	Voltage Terminal	Output Terminal
1766-L16AWA	Group 0	VAC/VDC 0	O/0
	Group 1	VAC/VDC 1	O/1
	Group 2	VAC/VDC 2	O/2
	Group 3	VAC/VDC 3	O/3
	Group 4	VAC/VDC 4	O/4
	Group 5	VAC/VDC 0	O/5
1766-L16BWA 1766-L16DWD	Group 0	VAC/VDC 0	O/0
	Group 1	VAC/VDC 1	O/1
	Group 2	VAC/VDC 2	O/2
	Group 3	VAC/VDC 3	O/3
	Group 4	VAC/VDC 4	O/4
	Group 5	VAC/VDC 0	O/5
1766-L16BBB	Group 0	VAC/VDC 0	O/0
	Group 1	VAC/VDC 1	O/1
	Group 2	DC +24V, DC -24V	O/2 through O/5

Sinking and Sourcing Wiring Diagrams

Any of the MicroLogix 1400 DC embedded input groups can be configured as sinking or sourcing depending on how the DC COM is wired on the group.

Type	Definition
Sinking Input	The input energizes when high-level voltage is applied to the input terminal (active high). Connect the power supply VDC (-) to the input group's COM terminal.
Sourcing Input	The input energizes when low-level voltage is applied to the input terminal (active low). Connect the power supply VDC (+) to the input group's COM terminal.



ATTENTION: The 24V DC sensor power source must not be used to power output circuits. It should only be used to power input devices (for example, sensors, switches). See Master Control Relay on page 29 for information on MCR wiring in output circuits.

1766-L32BWA, 1766-L32AWA, 1766-L32BXB, 1766-L32BWAA, 1766-L32AWAA, 1766-L32BXBA Wiring Diagrams

TIP

In the following diagrams, lower case alphabetic subscripts are appended to common-terminal connections to indicate that different power sources may be used for different isolated groups, if desired.

Figure 6 - 1766-L32AWA/L32AWAA Input Wiring Diagram ⁽¹⁾

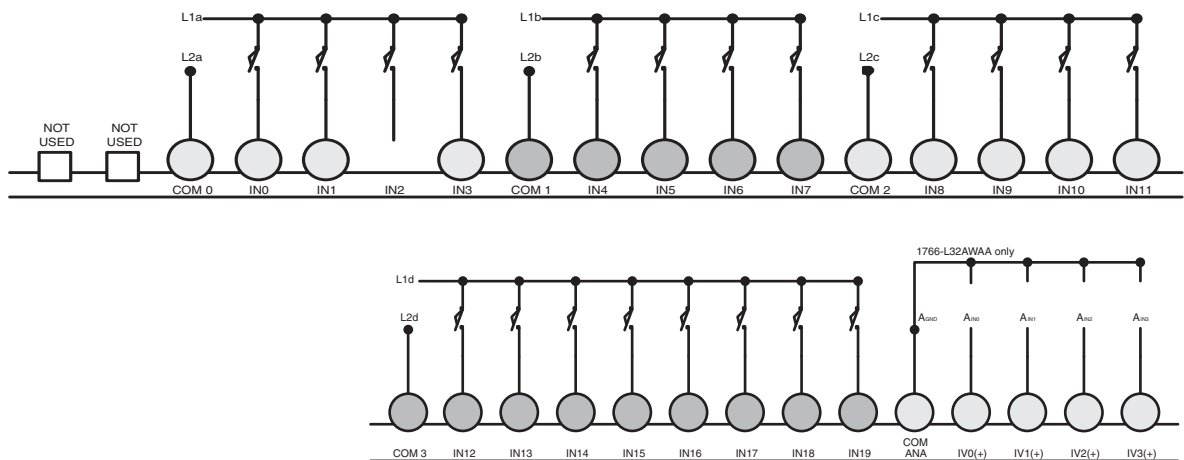

(1) "NOT USED" terminals are not intended for use as connection points.

Figure 7 - 1766-L32BWA/L32BWAA Sinking Input Wiring Diagram

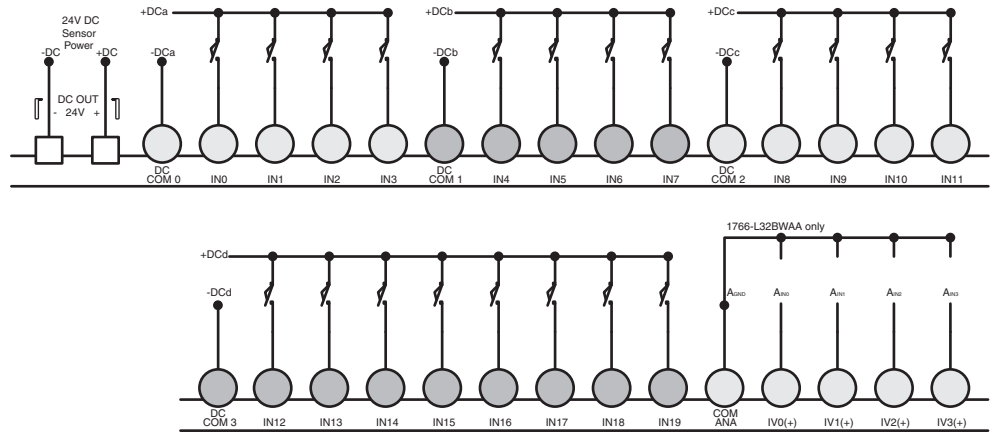

Figure 8 - 1766-L32BWA/L32BWAA Sourcing Input Wiring Diagram

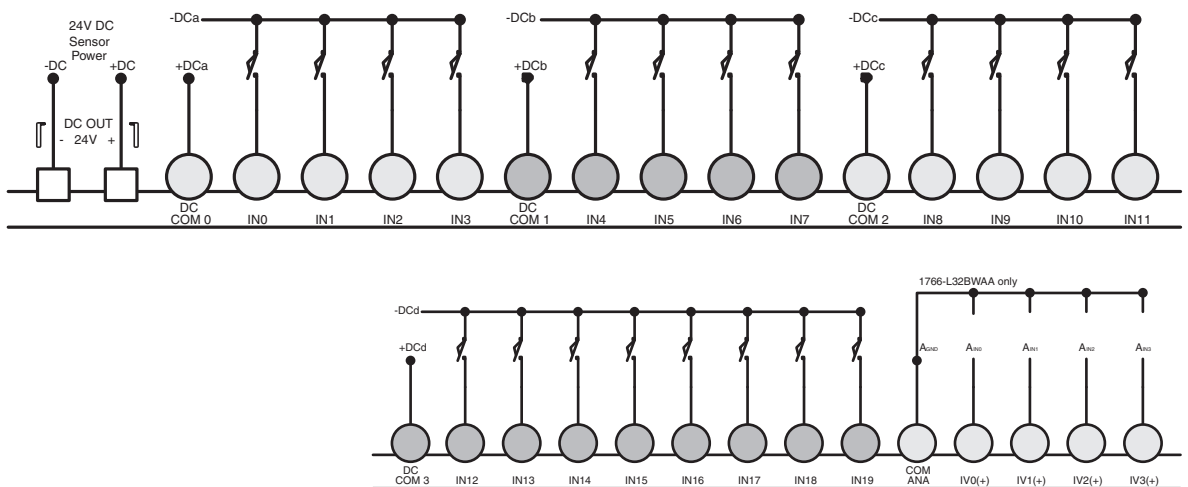

Figure 9 - 1766-L32BXB/L32BXBA Sinking Input Wiring Diagram

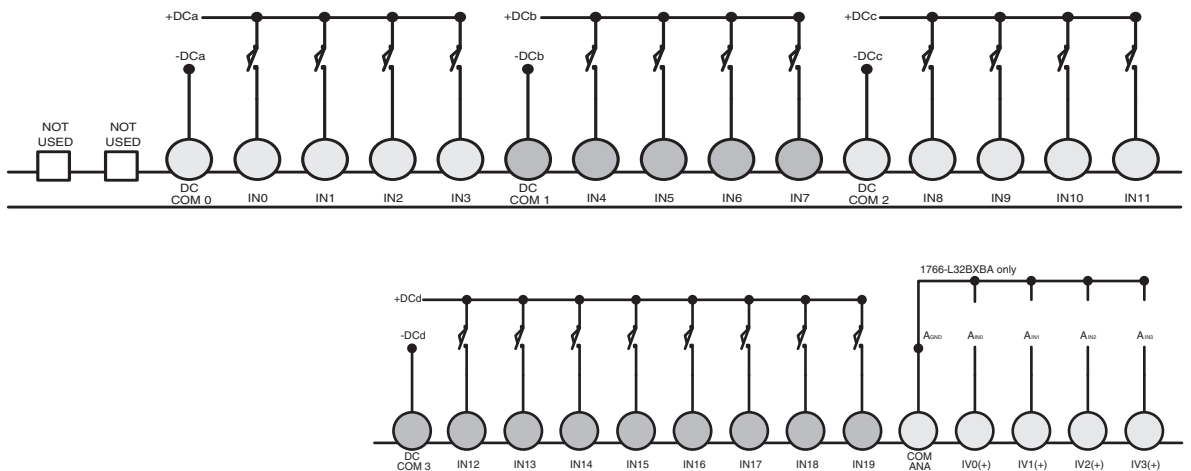

Figure 10 - 1766-L32BXB/L32BXBA Sourcing Input Wiring Diagram

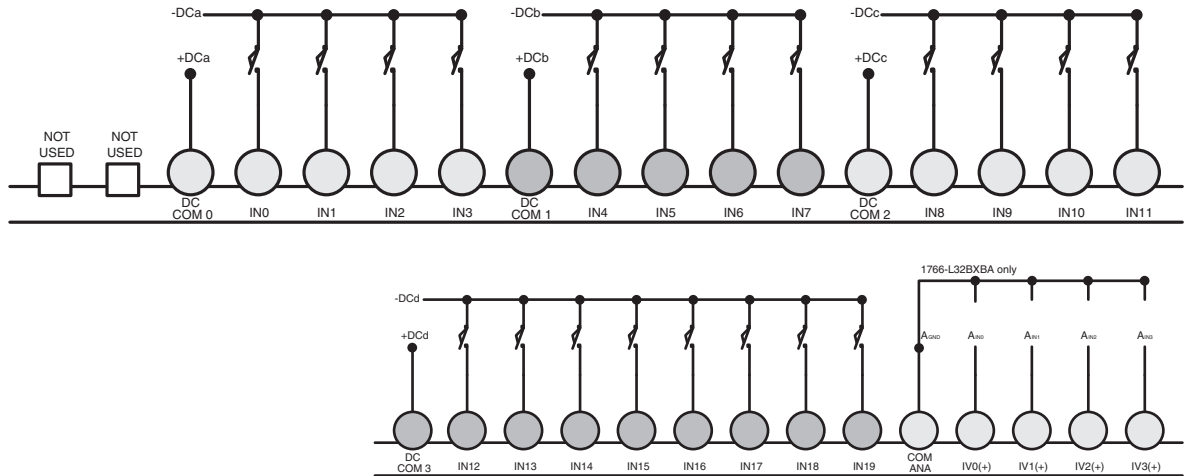

Figure 11 - 1766-L32AWA/L32AWAA and 1766-L32BWA/L32BWAA Output Wiring Diagram

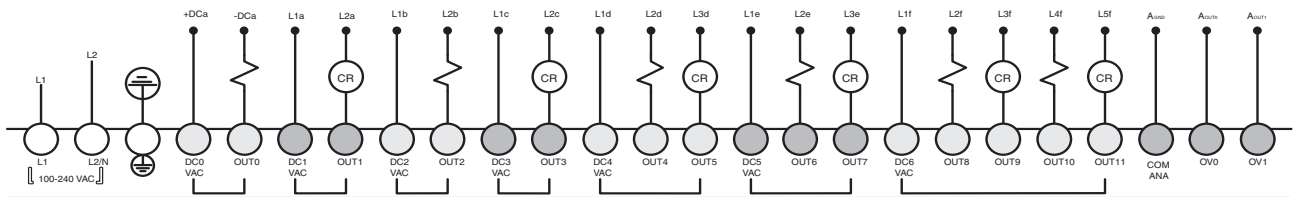
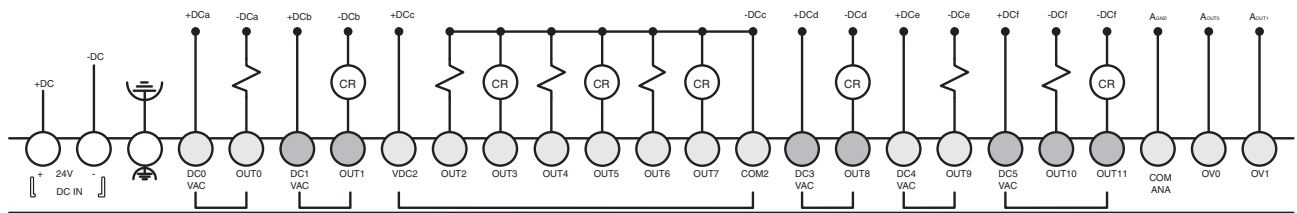

Figure 12 - 1766-L32BXB/L32BXBA Output Wiring Diagram



Controller I/O Wiring

Minimizing Electrical Noise

Because of the variety of applications and environments where controllers are installed and operating, it is impossible to ensure that all environmental noise will be removed by input filters. To help reduce the effects of environmental noise, install the MicroLogix 1400 system in a properly rated (for example, NEMA) enclosure. Make sure that the MicroLogix 1400 system is properly grounded.

A system may malfunction due to a change in the operating environment after a period of time. We recommend periodically checking system operation, particularly when new machinery or other noise sources are installed near the MicroLogix 1400 system.

Wiring Your Analog Channels

Analog input circuits can monitor voltage signals and convert them to serial digital data.

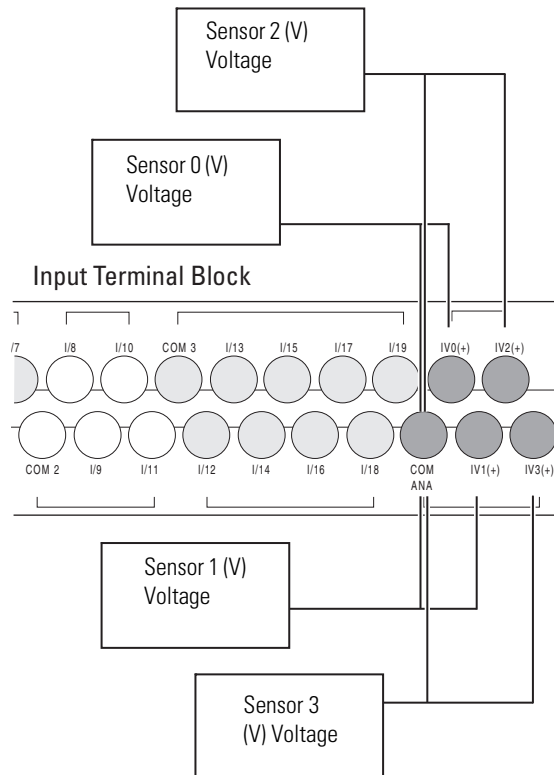

44529

The controller does not provide loop power for analog inputs. Use a power supply that matches the transmitter specifications as shown.

The analog output can support a voltage function as shown in the following illustration.

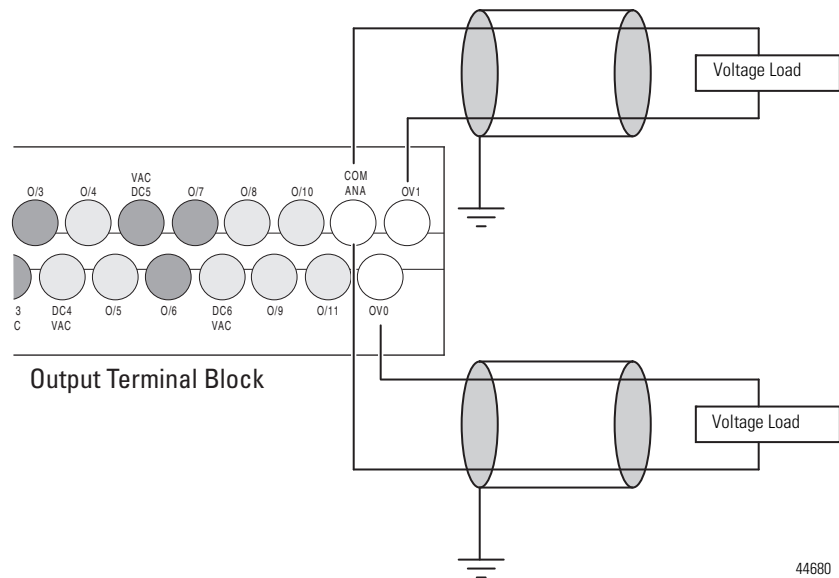
Figure 13 - Analog Output

44680

Analog Channel Wiring Guidelines

Consider the following when wiring your analog channels:

- The analog common (COM) is connected to earth ground inside the module. These terminals are not electrically isolated from the system. They are connected to chassis ground.
- Analog channels are not isolated from each other.
- Use Belden 8761, or equivalent, shielded wire.
- Under normal conditions, the drain wire (shield) should be connected to the metal mounting panel (earth ground). Keep the shield connection to earth ground as short as possible.
- To ensure optimum accuracy for voltage type inputs, limit overall cable impedance by keeping all analog cables as short as possible. Locate the I/O system as close to your voltage type sensors or actuators as possible.
- The controller does not provide loop power for analog inputs. Use a power supply that matches the transmitter specifications as shown below.

Figure 14 - Analog Input Transmitter Specifications

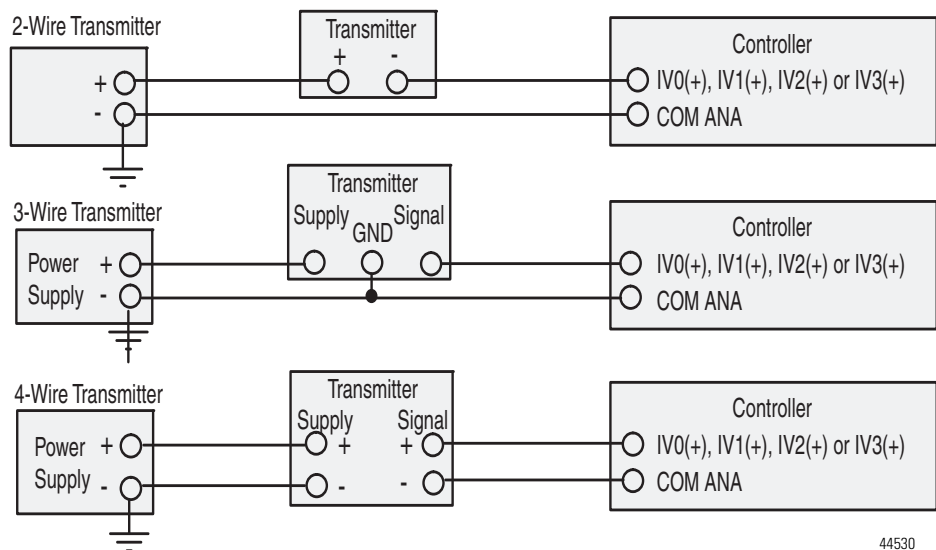

Minimizing Electrical Noise on Analog Channels

Inputs on analog channels employ digital high-frequency filters that significantly reduce the effects of electrical noise on input signals. However, because of the variety of applications and environments where analog controllers are installed and operated, it is impossible to ensure that all environmental noise will be removed by the input filters.

Several specific steps can be taken to help reduce the effects of environmental noise on analog signals:

- install the MicroLogix 1400 system in a properly rated enclosure, for example, NEMA. Make sure that the MicroLogix 1400 system is properly grounded.
- use Belden cable #8761 for wiring the analog channels, making sure that the drain wire and foil shield are properly earth grounded.
- route the Belden cable separately from any AC wiring. Additional noise immunity can be obtained by routing the cables in grounded conduit.

Grounding Your Analog Cable

Use shielded communication cable (Belden #8761). The Belden cable has two signal wires (black and clear), one drain wire, and a foil shield. The drain wire and foil shield must be grounded at one end of the cable.

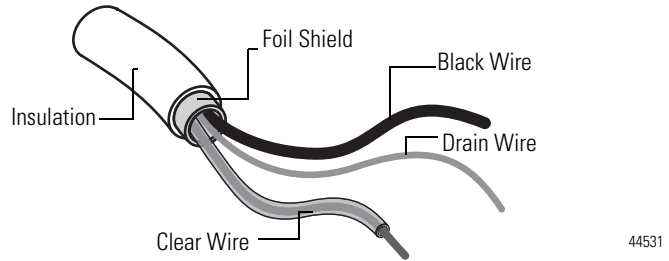

IMPORTANT Do not ground the drain wire and foil shield at both ends of the cable

Expansion I/O Wiring

Digital Wiring Diagrams

The following illustrations show the digital expansion I/O wiring diagrams.

Figure 15 - 1762-IA8 Wiring Diagram

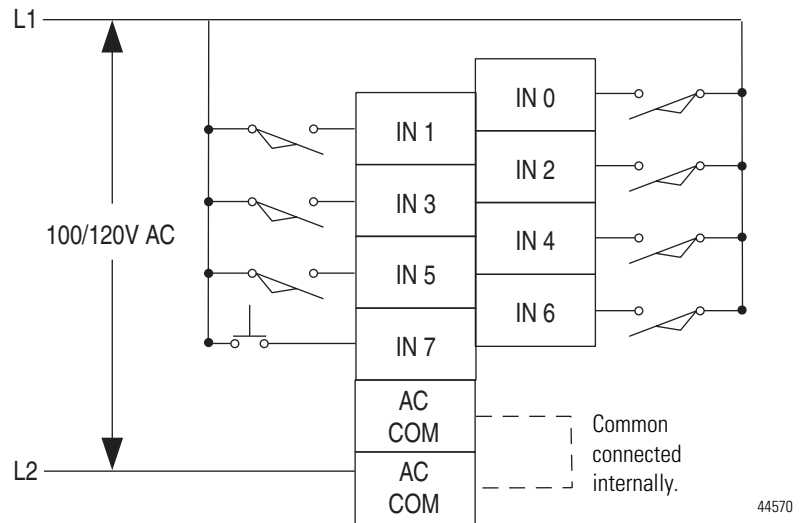

Figure 16 - 1762-IQ8 Wiring Diagram

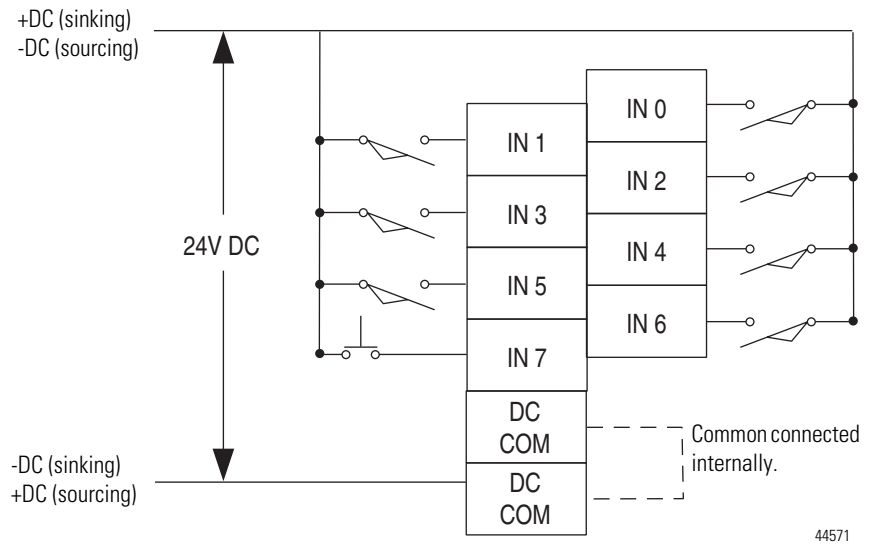

Figure 17 - 1762-IQ16 Wiring Diagram

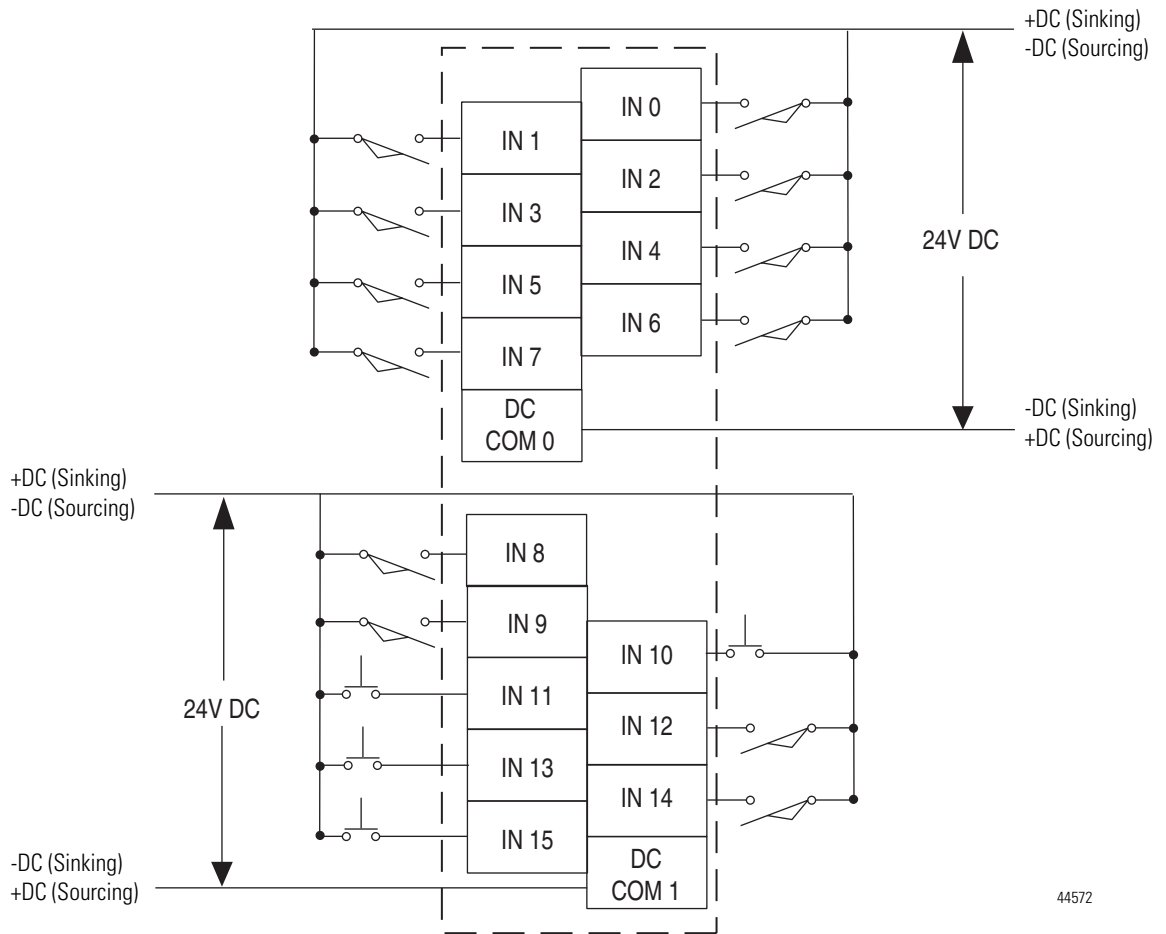

Figure 18 - 1762-IO32T Wiring Diagram

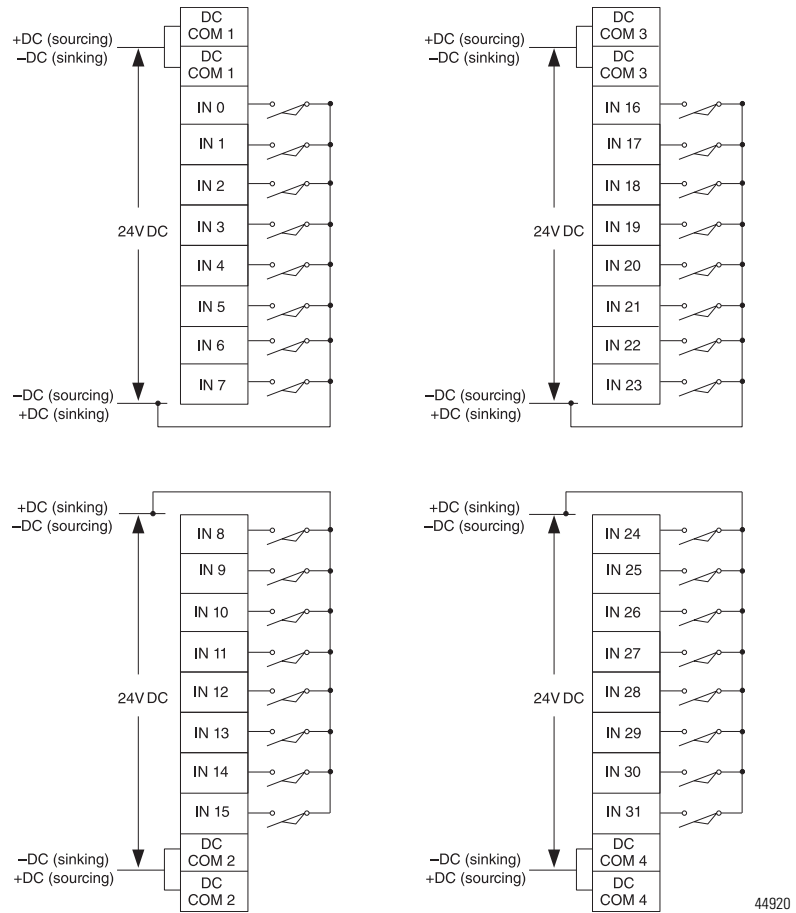

Figure 19 - 1762-OA8 Wiring Diagram

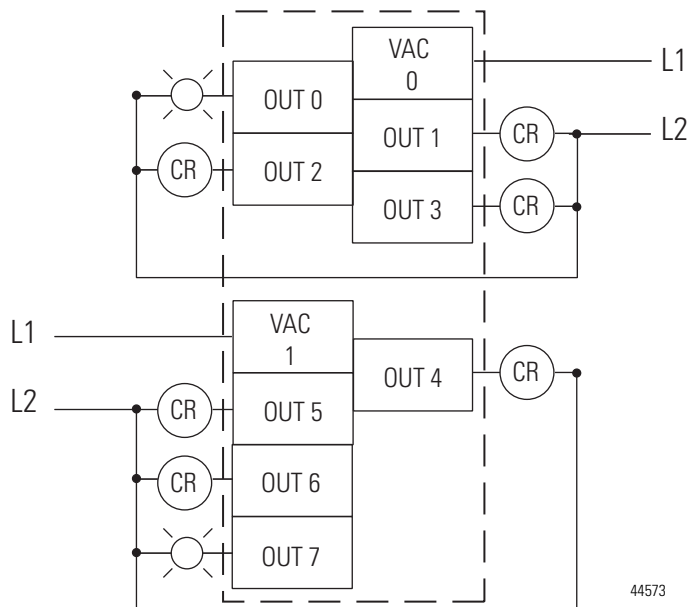

Figure 20 - 1762-OB8 Wiring Diagram

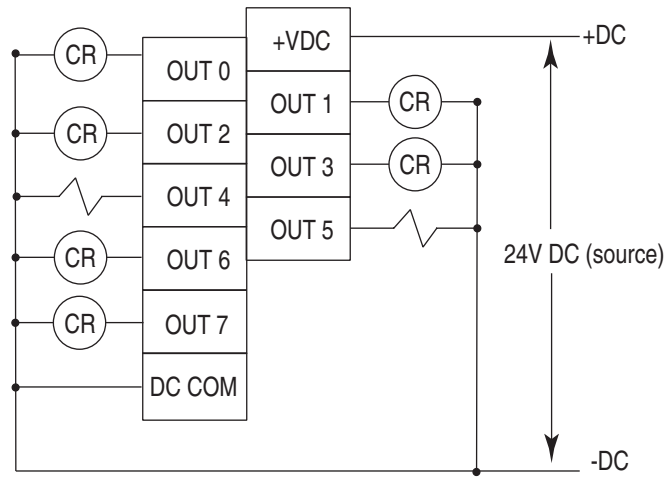

Figure 21 - 1762-OB16 Wiring Diagram

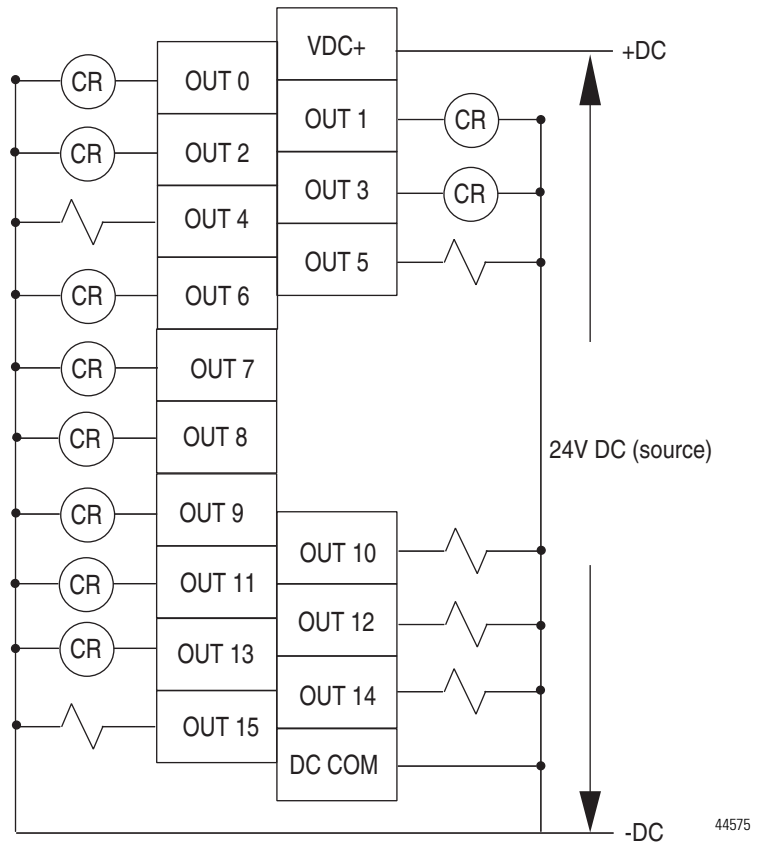
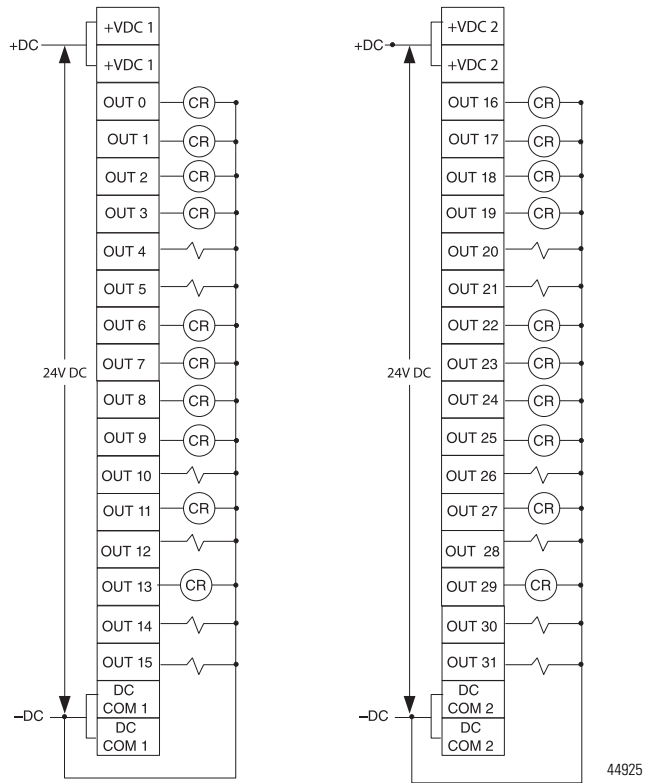

Figure 22 - 1762-OB32T Wiring Diagram



44925

Figure 23 - 1762-0V32T Wiring Diagram

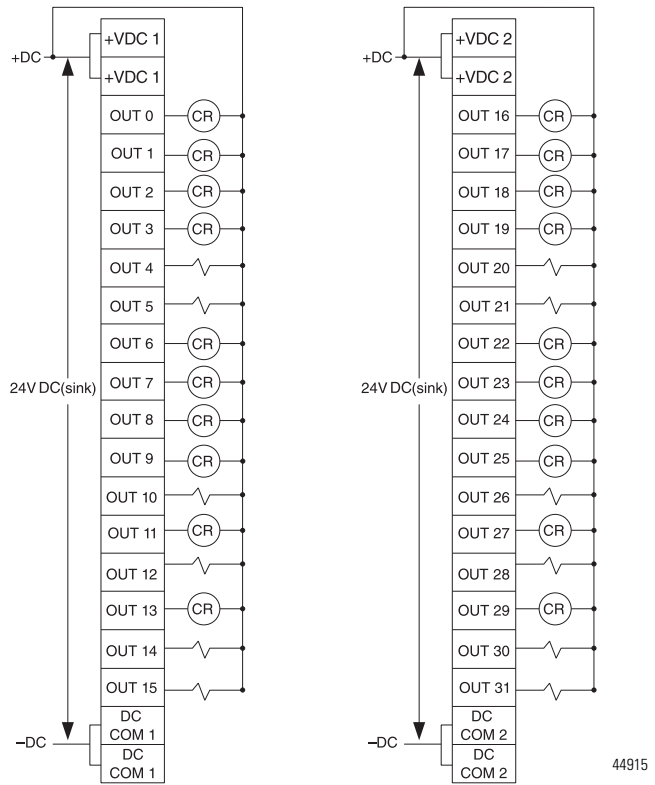

Figure 24 - 1762-0W8 Wiring Diagram

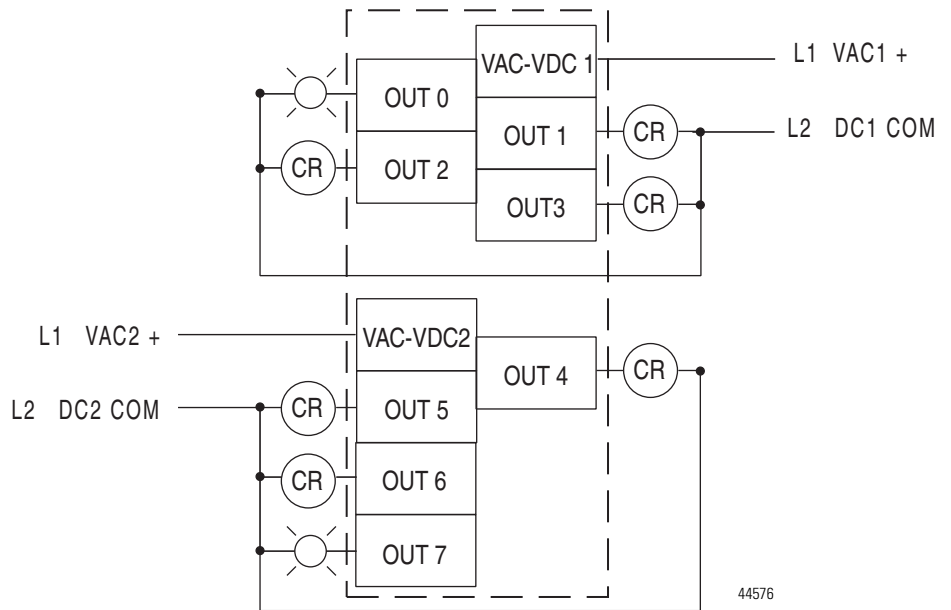

Figure 25 - 1762-OW16 Wiring Diagram

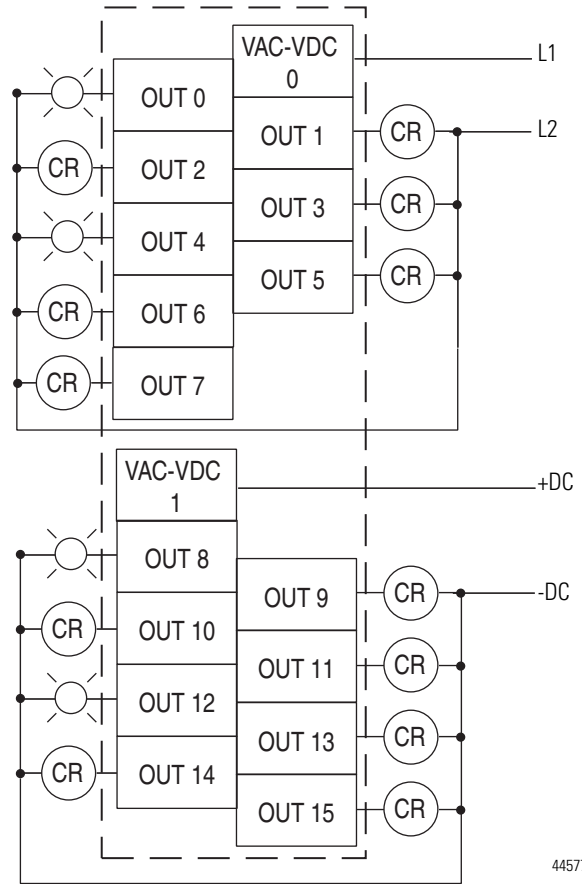
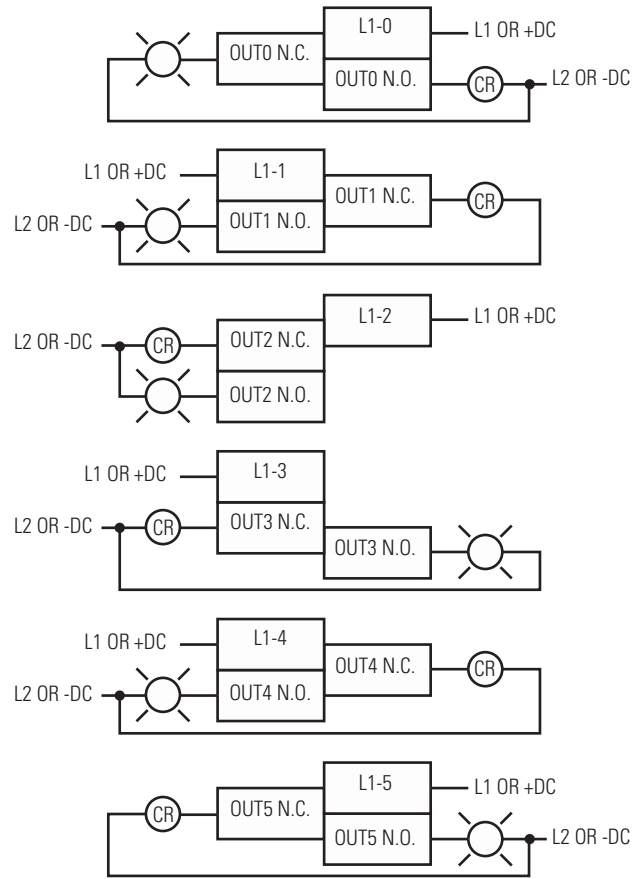
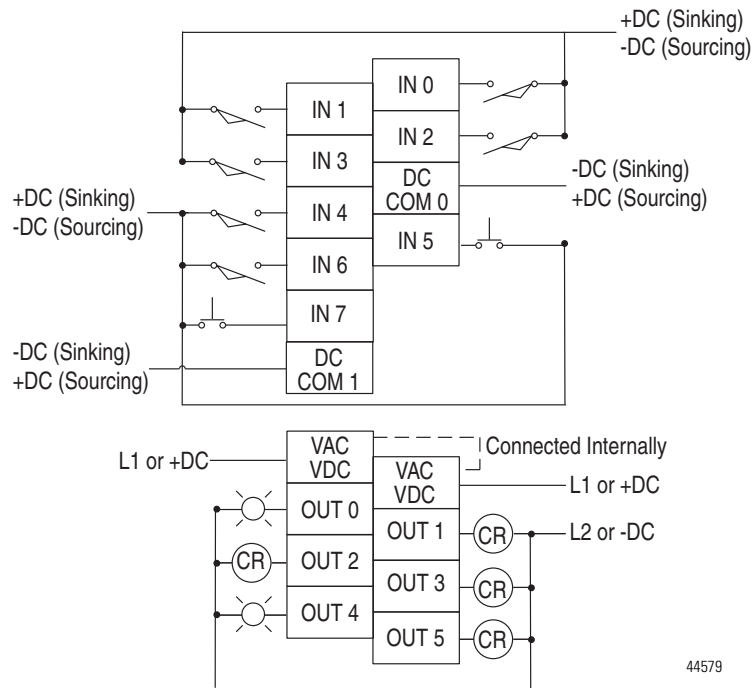

Figure 26 - 1762-0X6I Wiring Diagram



44578

Figure 27 - 1762-1Q80W6 Wiring Diagram

Analog Wiring

Consider the following when wiring your analog modules:

- The analog common (COM) is not connected to earth ground inside the module. All terminals are electrically isolated from the system.
- Channels are not isolated from each other.
- Use Belden 8761, or equivalent, shielded wire.
- Under normal conditions, the drain wire (shield) should be connected to the metal mounting panel (earth ground). Keep the shield connection to earth ground as short as possible.
- To ensure optimum accuracy for voltage type inputs, limit overall cable impedance by keeping all analog cables as short as possible. Locate the I/O system as close to your voltage type sensors or actuators as possible.
- The module does not provide loop power for analog inputs. Use a power supply that matches the input transmitter specifications.

1762-1F20F2 Input Type Selection

Select the input type, current or voltage, using the switches located on the module's circuit board *and* the input type/range selection bits in the Configuration Data File. Refer to MicroLogix 1400 Programmable Controllers Instruction Set Reference Manual, publication [1766-RM001](#). You can access the switches through the ventilation slots on the top of the module. Switch 1 controls

channel 0; switch 2 controls channel 1. The factory default setting for both switch 1 and switch 2 is Current. Switch positions are shown below.

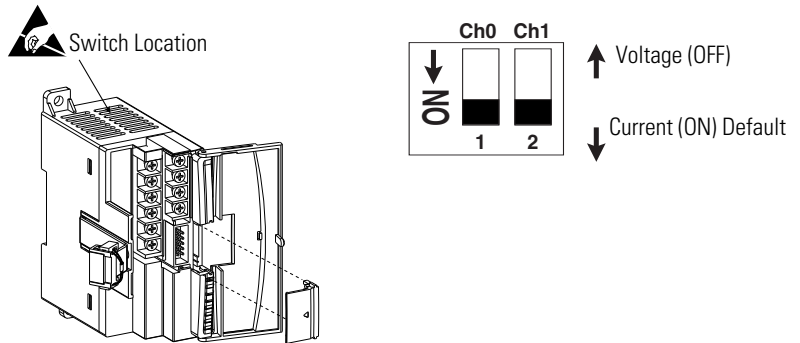

1762-IF2OF2 Output Type Selection

The output type selection, current or voltage, is made by wiring to the appropriate terminals, Iout or Vout, *and* by the type/range selection bits in the Configuration Data File. Refer to MicroLogix 1400 Programmable Controllers Instruction Set Reference Manual, publication [1766-RM001](#).



ATTENTION: Analog outputs may fluctuate for less than a second when power is applied or removed. This characteristic is common to most analog outputs. While the majority of loads will not recognize this short signal, it is recommended that preventive measures be taken to ensure that connected equipment is not affected.

1762-IF2OF2 Wiring

The following illustration shows the 1762-IF2OF2 analog expansion I/O terminal block.

Figure 28 - 1762-IF20F2 Terminal Block Layout

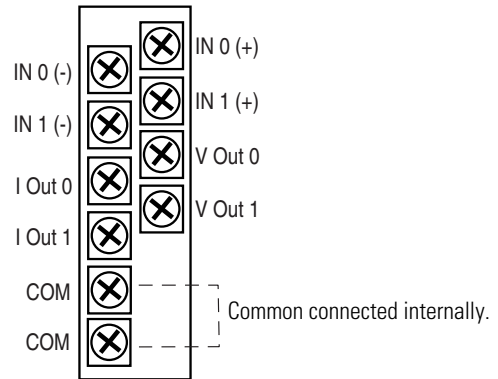

Figure 29 - Differential Sensor Transmitter Types

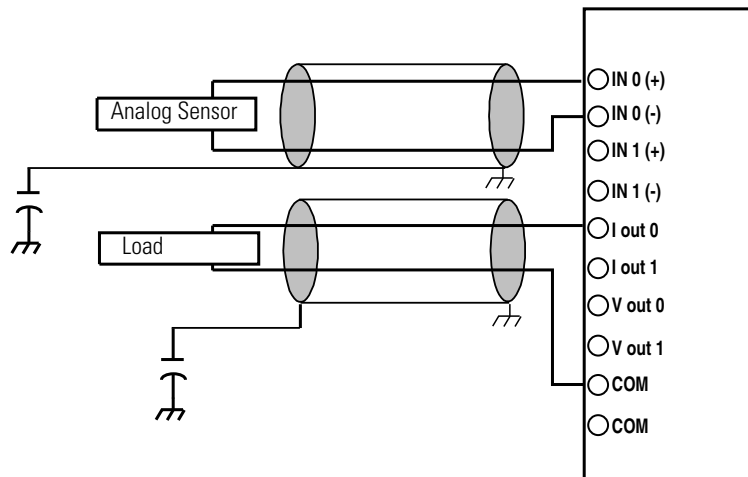
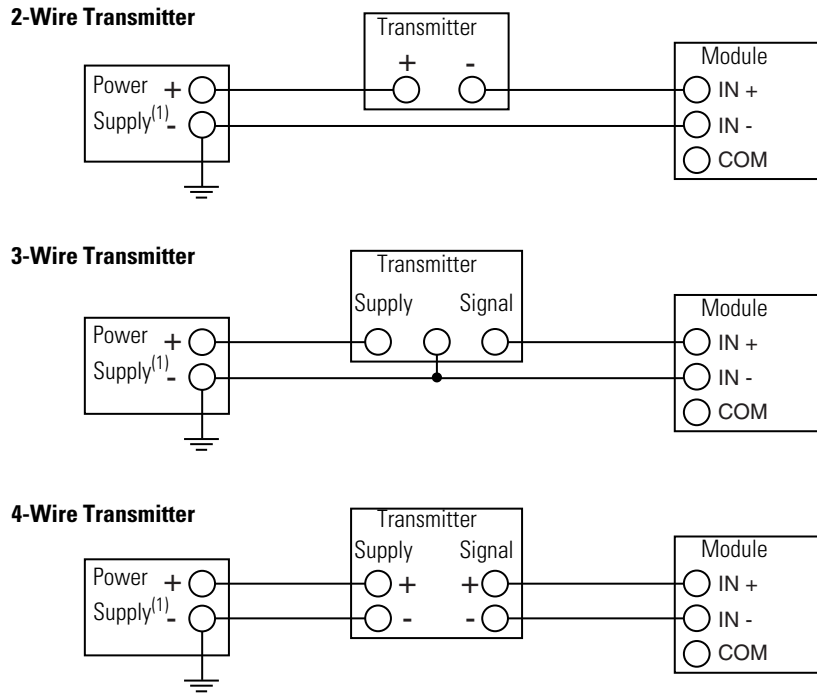

Figure 30 - Single-ended Sensor/Transmitter Types



(1) All power supplies rated N.E.C. Class 2.

1762-IF4 Input Type Selection

Select the input type, current or voltage, using the switches located on the module's circuit board *and* the input type/range selection bits in the Configuration Data File. Refer to *MicroLogix 1400 Programmable Controllers Instruction Set Reference Manual*, publication 1766-RM001. You can access the switches through the ventilation slots on the top of the module.

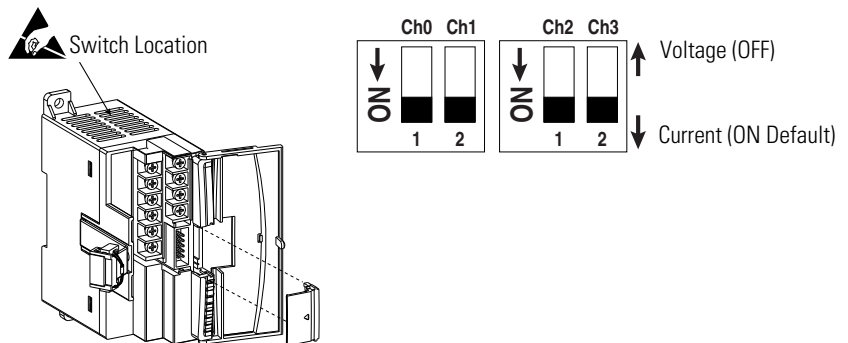

Figure 31 - 1762-IF4 Terminal Block Layout

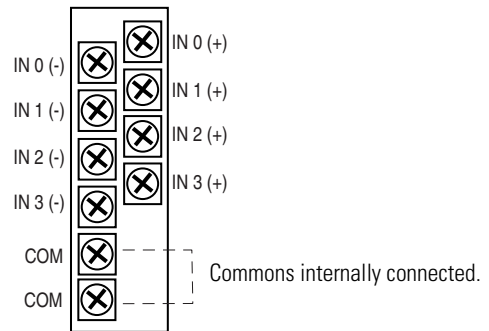
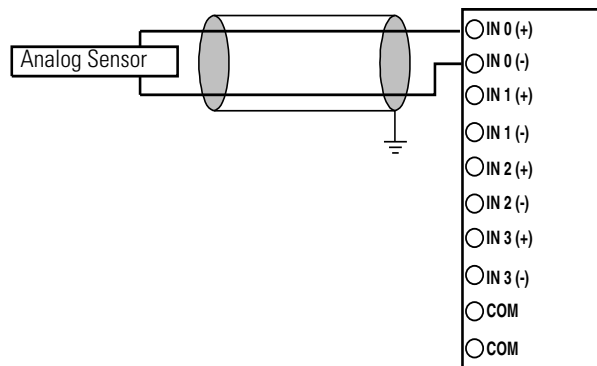
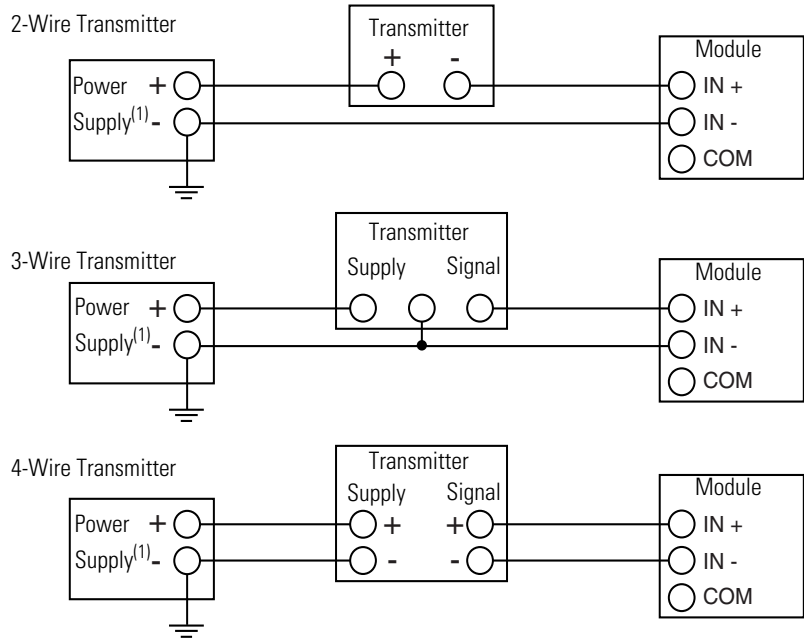

Figure 32 - Differential Sensor Transmitter Types



TIP Grounding the cable shield at the module end only usually provides sufficient noise immunity. However, for best cable shield performance, earth ground the shield at both ends, using a 0.01 μ F capacitor at one end to block AC power ground currents, if necessary.

Figure 33 - Sensor/Transmitter Types



⁽¹⁾ All power supplies rated N.E.C. Class 2.

1762-OF4 Output Type Selection

The output type selection, current or voltage, is made by wiring to the appropriate terminals, Iout or Vout, *and* by the type/range selection bits in the Configuration Data File.

1762-OF4 Terminal Block Layout

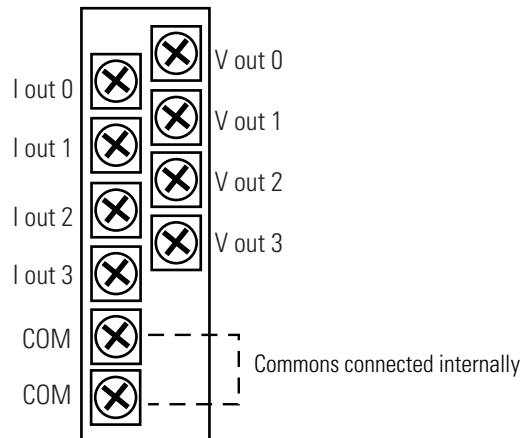

1762-OF4 Wiring

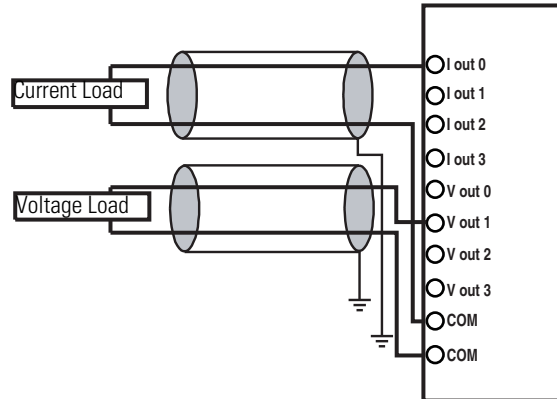

Communication Connections

This chapter describes how to communicate with your control system. The method you use and cabling required to connect your controller depends on what type of system you are employing. This chapter also describes how the controller establishes communication with the appropriate network. Topics include:

- supported communication protocols
- default communication configurations
- using communications toggle functionality
- connecting to RS-232 port
- connecting to RS-485 network
- connecting to AIC+
- connecting to Ethernet

The MicroLogix 1400 controllers provide three communication channels, an isolated RS-232/485 communication port (Channel 0), an Ethernet port (Channel 1) and a non-isolated RS-232 communication port (Channel 2).

Supported Communication Protocols

MicroLogix 1400 controllers support the following communication protocols from the primary RS-232/485 communication channel 0 and the RS-232 communication channel 2:

- DH-485
- DF1 Full-Duplex
- DF1 Half-Duplex Master and Slave
- DF1 Radio Modem
- Modbus RTU Master and Slave
- ASCII
- DNP3 Slave

The Ethernet communication channel, Channel 1, allows your controller to be connected to a local area network for various devices providing 10 Mbps/100 Mbps transfer rate. MicroLogix 1400 controllers support Ethernet/IP with CIP explicit messaging (message exchange), BOOTP/DHCP Client, HTTP Server, SMTP Client, DNS Client, SNMP Server, Socket Interface with CIP Generic messaging, Modbus TCP Client/Server and DNP3 over IP. MicroLogix 1400 controllers do not support Ethernet I/O master capability through CIP implicit messaging (real-time I/O messaging).

For more information on MicroLogix 1400 communications, refer to the MicroLogix 1400 Programmable Controllers Instruction Set Reference Manual, publication 1766-RM001.

Default Communication Configuration

The MicroLogix 1400 communication Channel 0 has the following default communication configuration.

TIP

For Channel 0, the default configuration is present when:

- The controller is powered-up for the first time.
- The communications toggle functionality specifies default communications (specified using the LCD Display. The DCOMM indicator on the LCD Display is on, that is, lit in solid rectangle).
- An OS upgrade is completed.

See Chapter 5 for more information about using the LCD Display.

See Appendix E for more information about communicating.

DF1 Full-Duplex Default Configuration Parameters

Parameter	Default
Baud Rate	19.2 Kbps
Parity	none
Source ID (Node Address)	1
Control Line	no handshaking
Error Detection	CRC
Embedded Responses	auto detect
Duplicate Packet (Message) Detect	enabled
ACK Timeout	50 counts
NAK retries	3 retries
ENQ retries	3 retries
Stop Bits	1
Data Bits	8

Using the Communications Toggle Functionality

The Communications Toggle Functionality can be operated using the LCD display on the controller, as shown below.

Use the Communications Toggle Functionality to change from the user-defined communication configuration to the default communications mode and back on Channel 0. The Default Communications (DCOMM) indicator on the LCD display operates to show when the controller is in the default communications

mode. Hold down the OK key more than 5 seconds to toggle the communication mode on the Main Menu screen.

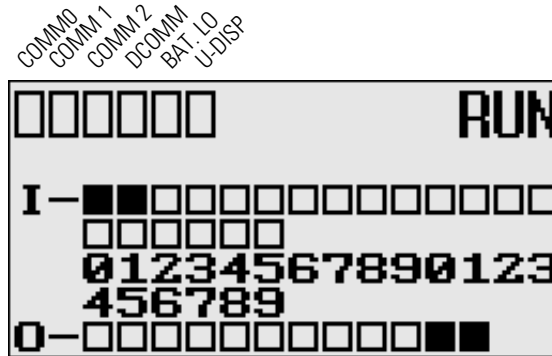

TIP The Communication Toggle Functionality only affects the communication configuration of Channel 0.

Changing Communication Configuration

Follow the procedure below to change from the user-defined communication configuration to the default communications mode and back. In this example, we will start from the Main Menu screen of the LCD display, as shown below. If necessary, press ESC repeatedly until you return to the Main Menu screen.

1. On the Main Menu screen, select Advance Set by using the Up and Down keys on the LCD keypad. If the menu items shown in the figure below are not displayed on the Main Menu screen, you need to scroll down the screen by pressing the Down key.



2. Press the OK key on the LCD keypad. The Advanced Settings Menu screen is displayed.

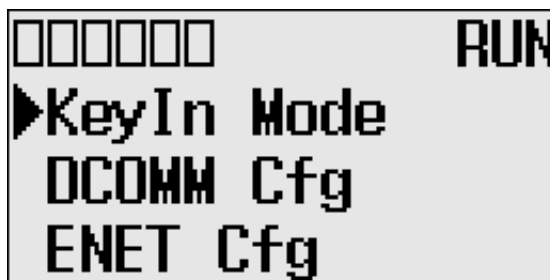

3. Select DCOMM Cfg using the Up and Down keys, and then press the OK key.

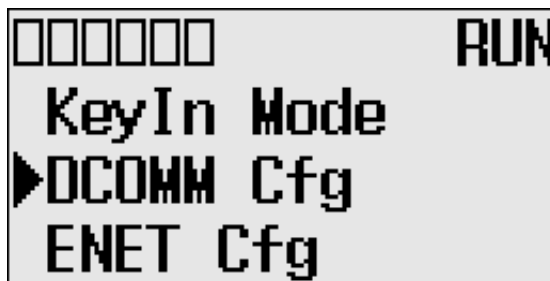

4. The DCOMM Configuration screen is displayed. In this example, the current status is Disable.

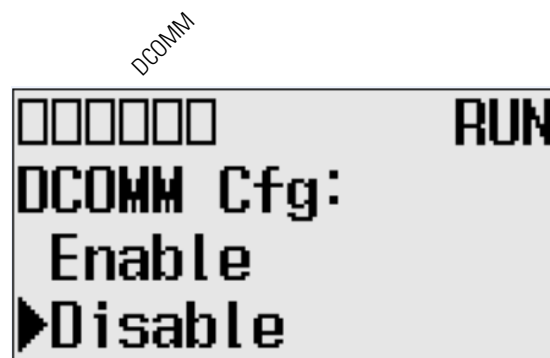

The DCOMM status indicator, which is the fourth of the six indicators at the top left of the LED display, is displayed as an empty rectangle. It means that the communication configuration is set to a user-defined communication mode at present.

- Use the up arrow to change the indicator position so that it is pointing to Enable. Press the OK key to change to the default communication mode.

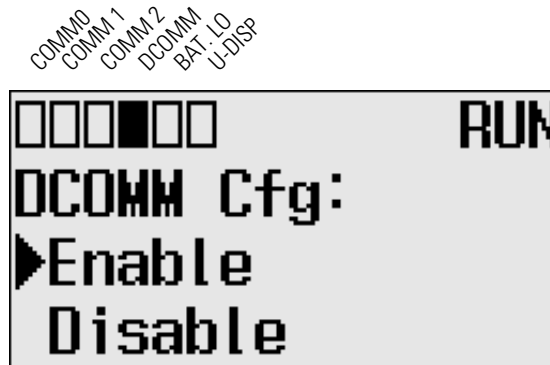

The DCOMM Mode Change Notification screen is displayed. It indicates that the communication configuration is changed to the default communication mode. The DCOMM status indicator is displayed in solid rectangle.

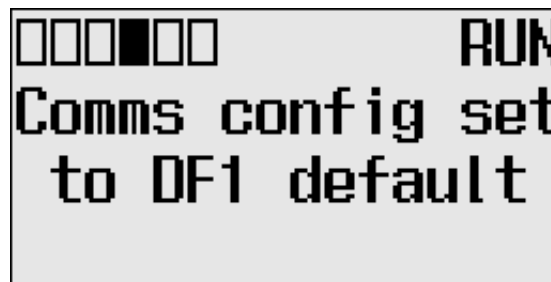

If you change to the user-defined configuration from the default configuration mode by selecting Disable and pressing the OK key, the DCOMM Mode Change Notification will be displayed.

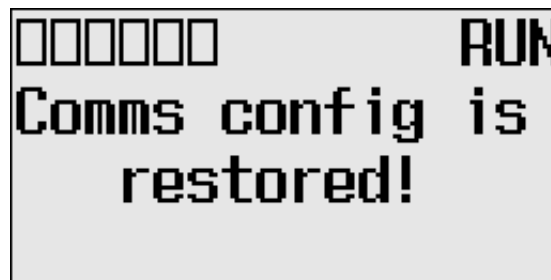

- Press the ESC key to return to the Advanced Set Menu screen, as shown in step 3.

Connecting to the RS-232 Port

There are two ways to connect the MicroLogix 1400 programmable controller to your personal computer using the DF1 protocol: using a point-to-point connection, or using a modem. Descriptions of these methods follow.



ATTENTION: All devices connected to the RS-232/485 communication port must be referenced to controller ground, or be floating (not referenced to a potential other than ground). Failure to follow this procedure may result in property damage or personal injury.

- For 1766-L32BWA controllers, the COM of the sensor supply is also connected to chassis ground internally. The 24V DC sensor power source should not be used to power output circuits. It should only be used to power input devices.
- For 1766-L32BxB controllers, the VDC NEUT or common terminal of the power supply is also connected to chassis ground internally.

Available Communication Cables

Communication Cables	Length
1761-CBL-AM00 Series C or later cables are required for Class I Div 2 applications.	45 cm (17.7 in.)
1761-CBL-AP00 Series C or later cables are required for Class I Div 2 applications.	45 cm (17.7 in.)
1761-CBL-PM02 Series C or later cables are required for Class I Div 2 applications.	2 m (6.5 ft)
1761-CBL-HM02 Series C or later cables are required for Class I Div 2 applications.	2 m (6.5 ft)
2707-NC9 Series C or later cables are required for Class I Div 2 applications.	15 m (49.2 ft)
1763-NC01 Series A or later	30 cm (11.8 in.)
1747-CP3 Series A or later	3 m (9.8 ft)



ATTENTION: UNSUPPORTED CONNECTION

Do not connect a MicroLogix 1400 controller to another MicroLogix family controller such as MicroLogix 1000, MicroLogix 1200, MicroLogix 1500, or to the 1747-DPS1 Network port using a 1761-CBL-AM00 (8-pin mini-DIN to 8-pin mini-DIN) cable or equivalent.

This type of connection will cause damage to the RS-232/485 communication port (Channel 0) of the MicroLogix 1400 and/or the controller itself. Communication pins used for RS-485 communications are alternately used for 24V power on the other MicroLogix controllers and the 1747-DPS1 network port .

Making a DF1 Point-to-Point Connection

You can connect the MicroLogix 1400 programmable controller to your personal computer using a serial cable (1761-CBL-PM02) from your personal computer's serial port to the controller's Channel 0. The recommended protocol for this configuration is DF1 Full-Duplex.

You can connect a MicroLogix 1400 controller to your personal computer directly without using an external optical isolator, such as Advanced Interface

Converter (AIC+), catalog number 1761-NET-AIC, as shown in the illustration below, because Channel 0 is isolated within the controller.

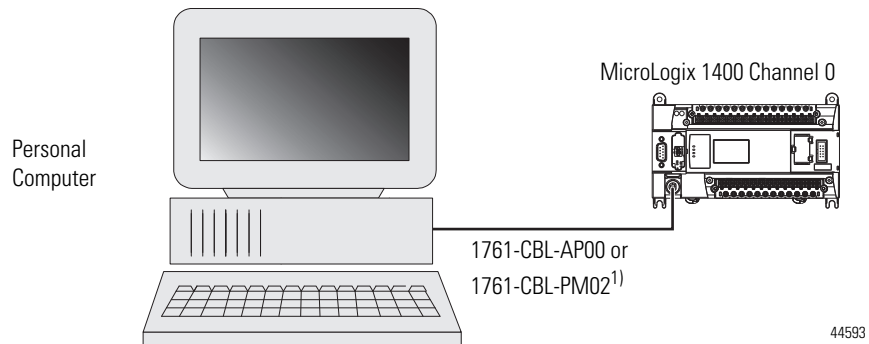

(1) Series C or later cables are required for Class I Div 2 applications.

Using a Modem

You can use modems to connect a personal computer to one MicroLogix 1400 controller (using DF1 Full-Duplex protocol), to multiple controllers (using DF1 Half-Duplex protocol), or Modbus RTU Slave protocol via Channel 0, as shown in the following illustration. (See Appendix E for information on types of modems you can use with the micro controllers.)

IMPORTANT Do not attempt to use DH-485 protocol through modems under any circumstance. The communication timing using DH-485 protocol is not supported by modem communications.

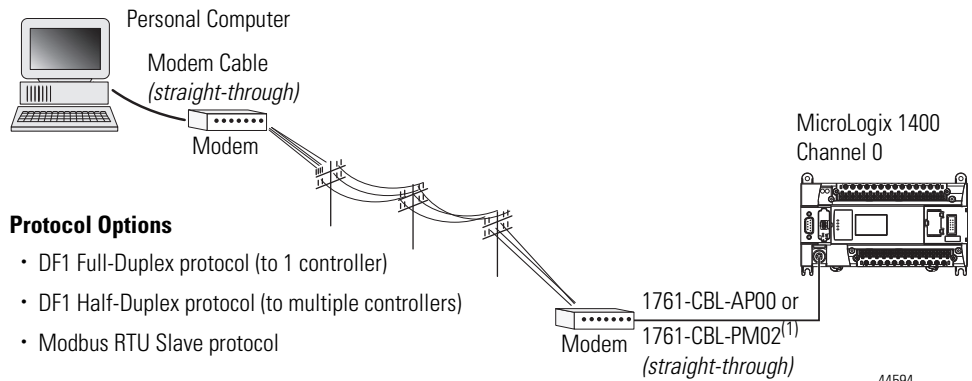

Protocol Options

- DF1 Full-Duplex protocol (to 1 controller)
- DF1 Half-Duplex protocol (to multiple controllers)
- Modbus RTU Slave protocol

(1) Series C or later cables are required for Class I Div 2 applications.

You can connect a MicroLogix 1400 controller to your modem directly without using an external optical isolator, such as AIC+, catalog number 1761-NET-AIC, as shown in the illustration below, because Channel 0 is isolated within the controller.

MicroLogix 1400 Channel 0 to Modem Cable Pinout

When connecting MicroLogix 1400 Channel 0 to a modem using an RS-232 cable, the maximum that the cable length may be extended is 15.24 m (50 ft).

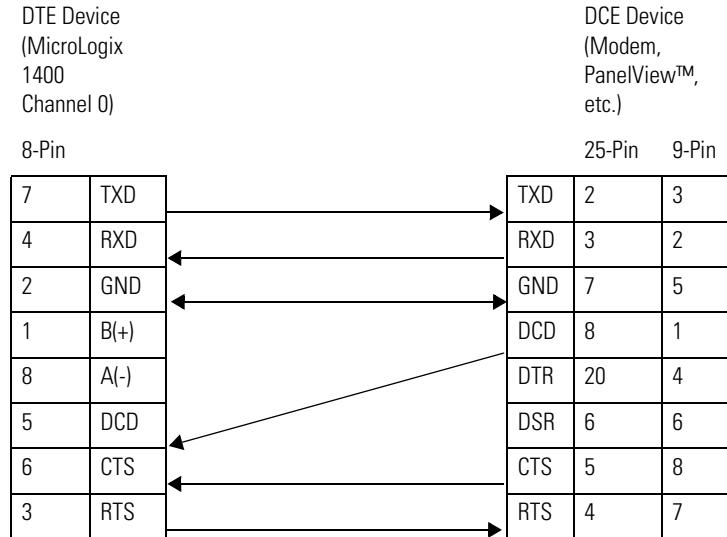

ATTENTION: Do not connect pins 1 and 8. This connection will cause damage to the RS-232/485 communication port (channel 0) of the MicroLogix 1400 and/or the controller itself.

Constructing Your Own Modem Cable

If you construct your own modem cable, the maximum cable length is 15.24 m (50 ft) with a 25-pin or 9-pin connector. Refer to the following typical pinout for constructing a *straight-through* cable:

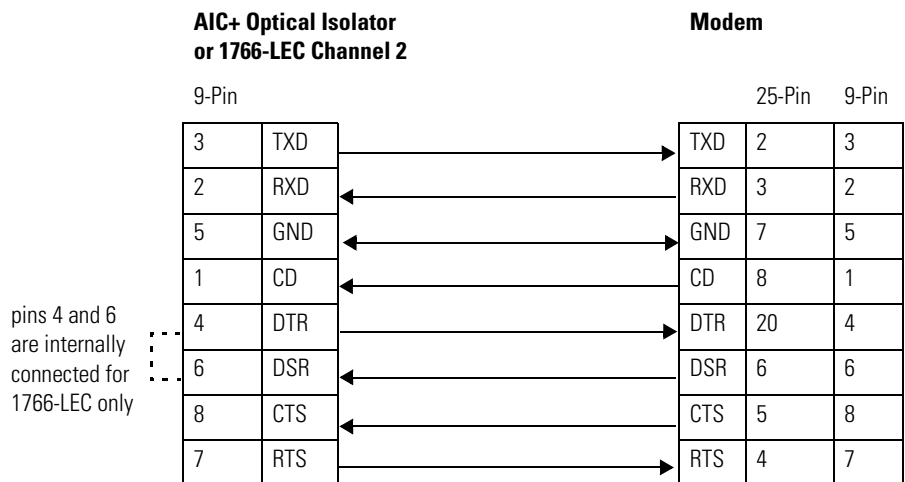

Constructing Your Own Null Modem Cable

If you construct your own null modem cable, the maximum cable length is 15.24m (50 ft) with a 25-pin or 9-pin connector. Refer to the following typical pinout:

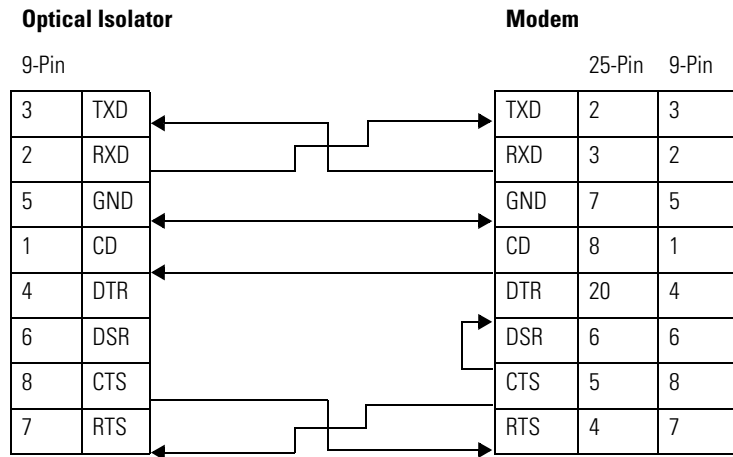

Connecting to a DF1 Half-Duplex Network

When a communication port is configured for DF1 Half-Duplex Slave, available parameters include the following:

DF1 Half-Duplex Configuration Parameters

Parameter	Options
Baud Rate	300, 600, 1200, 2400, 4800, 9600, 19.2 KBps, 38.4 KBps
Parity	none, even
Node Address	0...254 decimal
Control Line	no handshaking, half duplex modem (RTS/CTS handshaking, no handshaking (485 network))
Error Detection	CRC, BCC
EOT Suppression	enabled, disabled When EOT Suppression is enabled, the slave does not respond when polled if no message is queued. This saves modem transmission power and time when there is no message to transmit.
Duplicate Packet (Message) Detect	enabled, disabled Detects and eliminates duplicate responses to a message. Duplicate packets may be sent under noisy communication conditions if the sender's Message Retries are not set to 0.
Poll Timeout (x20 ms)	0...65,535 (can be set in 20 ms increments) Poll Timeout only applies when a slave device initiates a MSG instruction. It is the amount of time that the slave device waits for a poll from the master device. If the slave device does not receive a poll within the Poll Timeout, a MSG instruction error is generated, and the ladder program needs to requeue the MSG instruction. If you are using a MSG instruction, it is recommended that a Poll Timeout value of zero not be used. Poll Timeout is disabled when set to zero.
RTS Off Delay (x20 ms)	0...65,535 (can be set in 20 ms increments) Specifies the delay time between when the last serial character is sent to the modem and when RTS is deactivated. Gives the modem extra time to transmit the last character of a packet.
RTS Send Delay (x20 ms)	0...65,535 (can be set in 20 ms increments) Specifies the time delay between setting RTS until checking for the CTS response. For use with modems that are not ready to respond with CTS immediately upon receipt of RTS.
Message Retries	0...255 Specifies the number of times a slave device attempts to resend a message packet when it does not receive an ACK from the master device. For use in noisy environments where message packets may become corrupted in transmission.
Pre Transmit Delay (x1 ms)	0...65,535 (can be set in 1 ms increments) <ul style="list-style-type: none"> When the Control Line is set to <i>no handshaking</i>, this is the delay time before transmission. Required for 1761-NET-AIC physical Half-Duplex networks. The 1761-NET-AIC needs delay time to change from transmit to receive mode. When the Control Line is set to <i>DF1 Half-Duplex Modem</i>, this is the minimum time delay between receiving the last character of a packet and the RTS assertion.

DF1 Half-Duplex Master-Slave Network

Use the following diagram for DF1 Half-Duplex Master-Slave protocol without hardware handshaking.

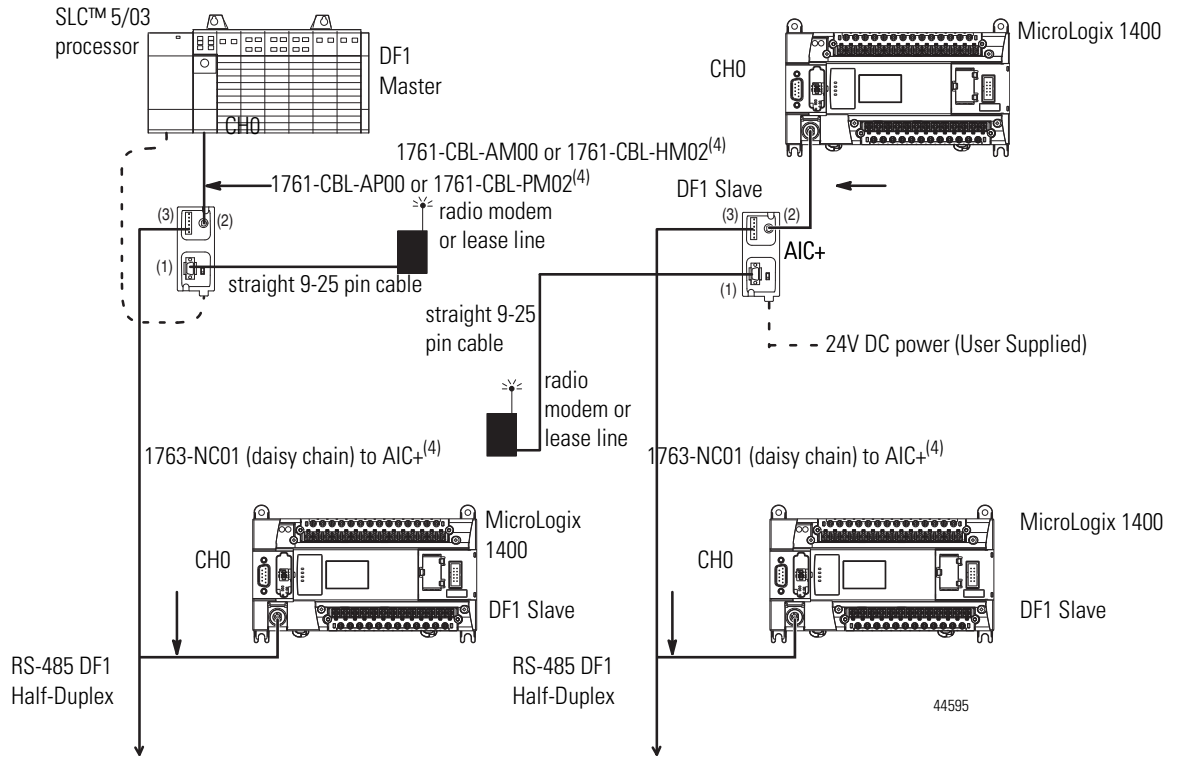

- (1) DB-9 RS-232 port
- (2) mini-DIN 8 RS-232 port
- (3) RS-485 port
- (4) Series C or later cables are required for Class I Div 2 applications.

DF1 Half-Duplex Network (Using PC and Modems)

Rockwell Software® RSLinx® 2.0 (or higher), SLC™ 5/03, SLC 5/04, SLC 5/05, PLC-5®, or MicroLogix 1000, 1200, and 1500 processors configured for DF1 Half-Duplex Master. Rockwell Software RSLinx 2.5 required for MicroLogix 1400.

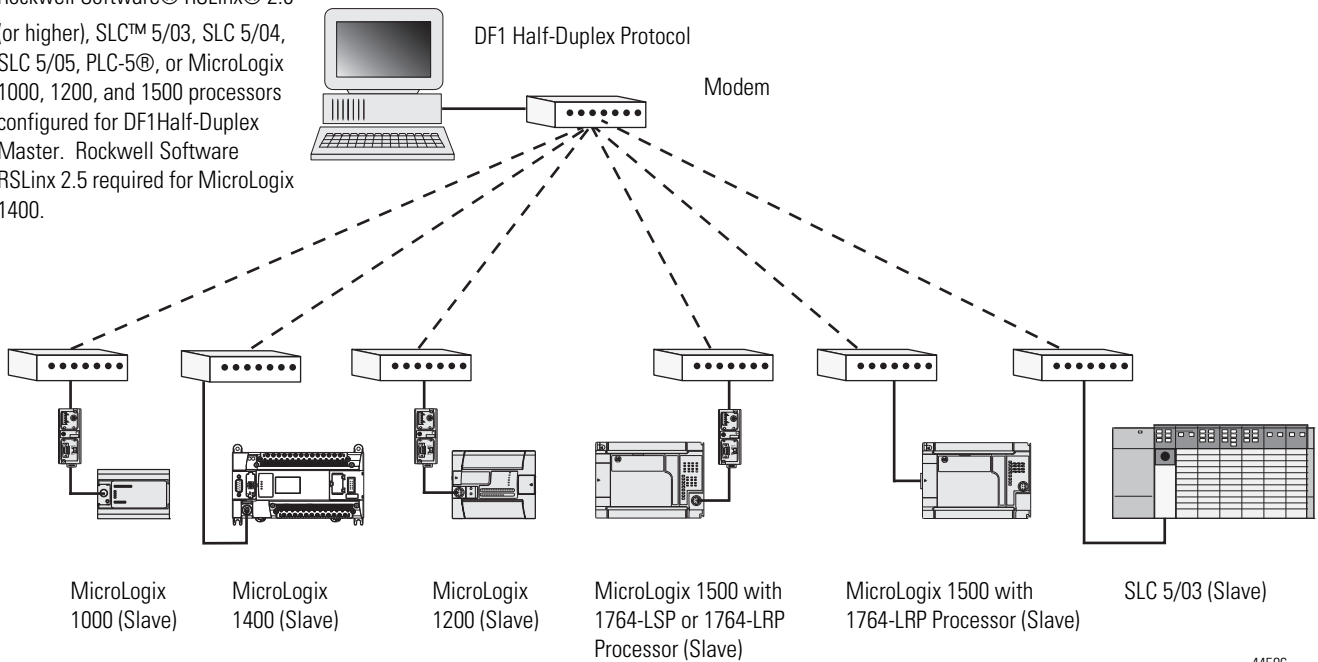

44596

Connecting to a RS-485 Network

The network diagrams on the next pages provide examples of how to connect MicroLogix 1400 controllers to the RS-485 network.

You can connect a MicroLogix 1400 controller to your RS-485 network directly without using an external optical isolator, such as Advanced Interface Converter (AIC+), catalog number 1761-NET-AIC, as shown in the illustrations below, because Channel 0 is isolated within the controller.

TIP

Use a 1763-NC01 Series A or later (8-pin mini-DIN to 6-pin RS-485 connector) cable or equivalent to connect a MicroLogix 1400 controller to a RS-485 network.

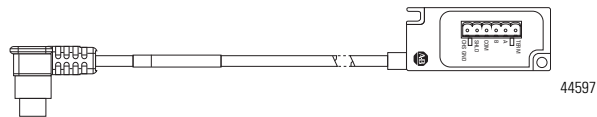

44597

MicroLogix 1400 controllers support various protocols on the RS-485 network, including DH-485, DF1 Half-Duplex Master/Slave, Modbus RTU Master/Slave, ASCII and DNP3 Slave protocols. In this section, DH-485 protocol is used as an example. Any physical connection should be the same as other protocols.

DH-485 Configuration Parameters

When MicroLogix communications are configured for DH-485, the following parameters can be changed:

DH-485 Configuration Parameters

Parameter	Options
Baud Rate	9600, 19.2 KBps
Node Address	1...31 decimal
Token Hold Factor	1...4

See [Software Considerations on page 245](#) for tips on setting the parameters listed above.

DH-485 Network with a MicroLogix 1400 Controller

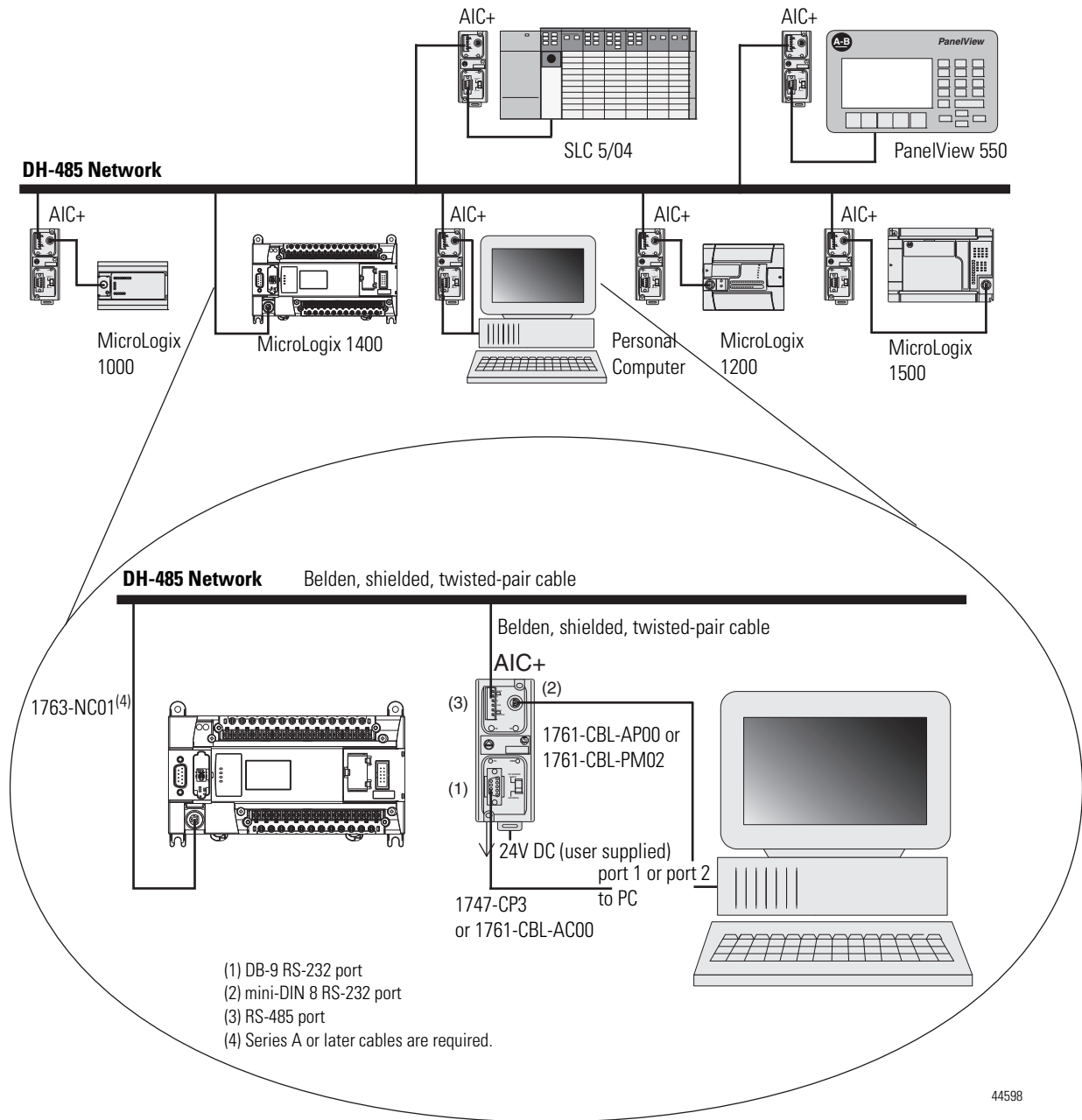

44598

Typical 3-Node Network (Channel 0 Connection)

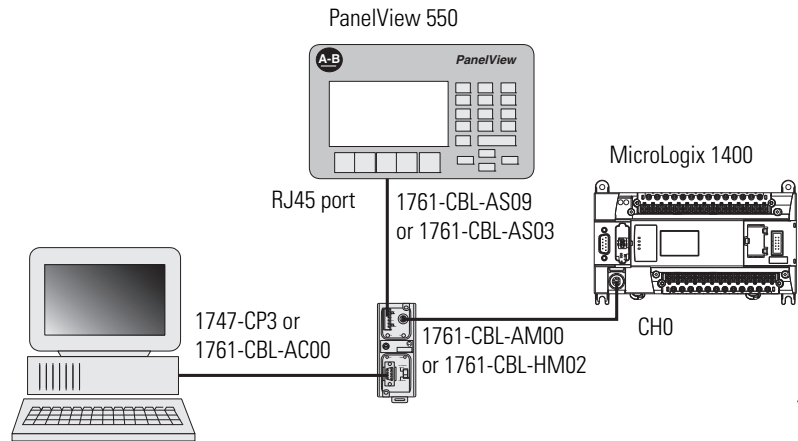

44599

Recommended Tools

To connect a DH-485 network to additional devices, you need tools to strip the shielded cable and to attach the cable to the AIC+ Advanced Interface Converter. We recommend the following equipment (or equivalent):

Working with Cable for DH-485 Network

Description	Part Number	Manufacturer
Shielded Twisted Pair Cable	#3106A or #9842	Belden
Stripping Tool	Not Applicable	Not Applicable
1/8" Slotted Screwdriver	Not Applicable	Not Applicable

DH-485 Communication Cable

The suggested DH-485 communication cable is either Belden #3106A or #9842. The cable is jacketed and shielded with one or two twisted-wire pairs and a drain wire.

One pair provides a balanced signal line and one additional wire is used for a common reference line between all nodes on the network. The shield reduces the effect of electrostatic noise from the industrial environment on network communication.

The communication cable consists of a number of cable segments daisy-chained together. The total length of the cable segments cannot exceed 1219 m (4000 ft). However, two segments can be used to extend the DH-485 network to 2438 m (8000 ft). For additional information on connections using the AIC+, refer to the Advanced Interface Converter (AIC+) User Manual, publication 1761-6.4.

When cutting cable segments, make them long enough to route them from one AIC+ to the next, with sufficient slack to prevent strain on the connector. Allow enough extra cable to prevent chafing and kinking in the cable.

Use these instructions for wiring the Belden #3106A or #9842 cable. (See Cable Selection Guide on page 93 if you are using standard Allen-Bradley cables.)

Connecting the Communication Cable to the DH-485 Connector

TIP A daisy-chained network is recommended. Do *not* make the incorrect connection shown below:

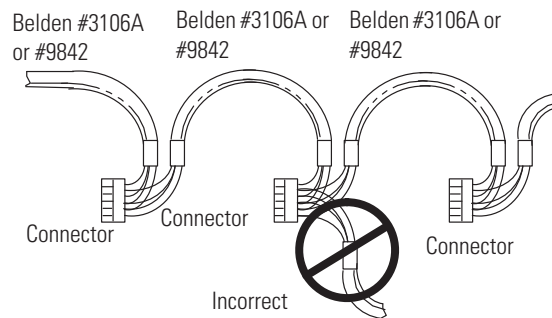

Single Cable Connection

When connecting a single cable to the DH-485 connector, use the following diagram.

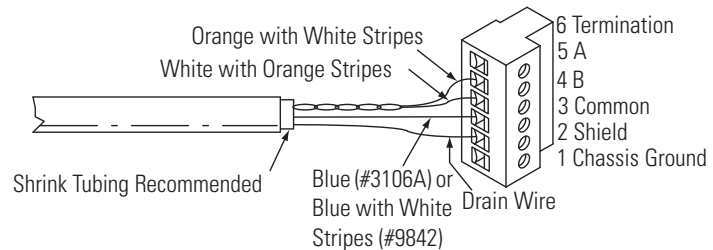

Multiple Cable Connection

When connecting multiple cables to the DH-485 connector, use the following diagram.

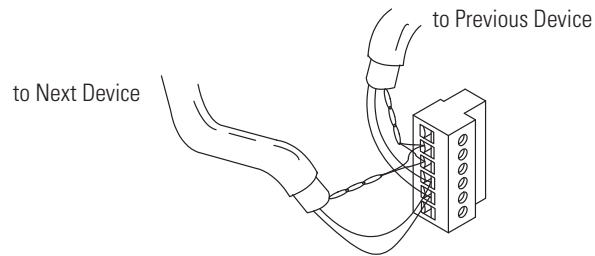

Connections using Belden #3106A Cable

For this Wire/Pair	Connect this Wire	To this Terminal
Shield/Drain	Non-jacketed	Terminal 2 - Shield
Blue	Blue	Terminal 3 - (Common)
White/Orange	White with Orange Stripe	Terminal 4 - (Data B)
	Orange with White Stripe	Terminal 5 - (Data A)

Connections using Belden #9842 Cable

For this Wire/Pair	Connect this Wire	To this Terminal
Shield/Drain	Non-jacketed	Terminal 2 - Shield
Blue/White	White with Blue Stripe	Cut back - no connection ⁽¹⁾
	Blue with White Stripe	Terminal 3 - (Common)
White/Orange	White with Orange Stripe	Terminal 4 - (Data B)
	Orange with White Stripe	Terminal 5 - (Data A)

⁽¹⁾ To prevent confusion when installing the communication cable, cut back the white with blue stripe wire immediately after the insulation jacket is removed. This wire is not used by DH-485.

Grounding and Terminating the DH-485 Network

Only one connector at the end of the link must have Terminals 1 and 2 jumpered together. This provides an earth ground connection for the shield of the communication cable.

Both ends of the network must have Terminals 5 and 6 jumpered together, as shown below. This connects the termination impedance (of 120 ohm) that is built into each AIC+ or the 1763-NC01 cable as required by the DH-485 specification.

End-of-Line Termination

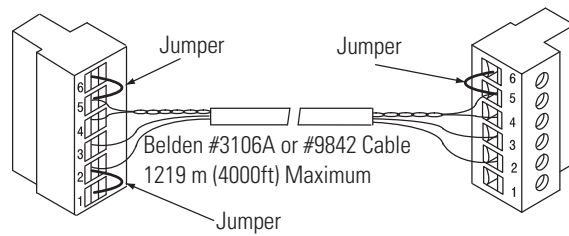

MicroLogix 1400 Channel 0 to DH-485 Communication Cable Pinout

When connecting MicroLogix 1400 Channel 0 to DH-485 communication cable pinout using an RS-232 cable, the maximum that the cable length may be extended is 15.24 m (50 ft). Refer to the following typical pinout:

DTE Device
(MicroLogix
1400
Channel 0)

DCE Device (DH-485
connector)

8-Pin

6-pin

7	TXD
4	RXD
2	GND
1	B(+)
8	A(-)
5	DCD
6	CTS
3	RTS

6	Termination
5	A
4	B
3	Common
2	Shield
1	ChassisGround

Connecting the AIC+

You can connect a MicroLogix 1400 controller to a DH-485 network via Channel 0 directly without using an optical isolator, such as AIC+, catalog number 1761-NET-AIC, because Channel 0 is isolated. However, you need to use an AIC+ to connect your PC or other MicroLogix Family products, such as MicroLogix 1200, to a DH-485 network.

The following figure shows the external wiring connections and specifications of the AIC+.

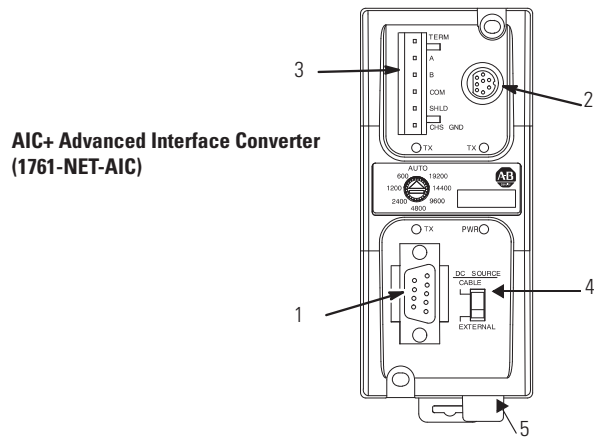

Item	Description
1	Port 1 - DB-9 RS-232, DTE
2	Port 2 - mini-DIN 8 RS-232 DTE
3	Port 3 - RS-485 Phoenix plug
4	DC Power Source selector switch (cable = port 2 power source, external = external power source connected to item 5)
5	Terminals for external 24V DC power supply and chassis ground

For additional information on connecting the AIC+, refer to the Advanced Interface Converter (AIC+) User Manual, publication [1761-UM001](#).

Cable Selection Guide

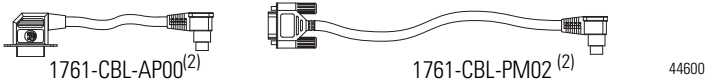

Cable	Length	Connections from	to AIC+	External Power Supply Required ⁽¹⁾	Power Selection Switch Setting ⁽¹⁾
1761-CBL-AP00 ⁽²⁾ 1761-CBL-PM02 ⁽²⁾	45 cm (17.7 in.) 2 m (6.5 ft)	SLC 5/03 or SLC 5/04 processors, ch 0	port 2	yes	external
		MicroLogix 1000, 1200, or 1500 ch 0	port 1	yes	external
		MicroLogix 1400 ch 2	port 2	yes	external
		PanelView 550 through NULL modem adapter	port 2	yes	external
		DTAM Plus / DTAM Micro	port 2	yes	external
		PC COM port	port 2	yes	external

⁽¹⁾ External power supply required unless the AIC+ is powered by the device connected to port 2, then the selection switch should be set to *cable*.

⁽²⁾ Series C or later cables are required.

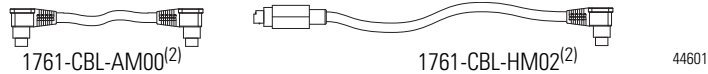

Cable	Length	Connections from	to AIC+	External Power Supply Required ⁽¹⁾	Power Selection Switch Setting
1761-CBL-AM00 ⁽²⁾ 1761-CBL-HM02 ⁽²⁾	45 cm (17.7 in.) 2 m (6.5 ft)	MicroLogix 1000, 1200, or 1500 ch 0	port 2	no	cable
		to port 2 on another AIC+	port 2	yes	external

⁽¹⁾ External power supply required unless the AIC+ is powered by the device connected to port 2, then the selection switch should be set to *cable*.

⁽²⁾ Series C or later cables are required.

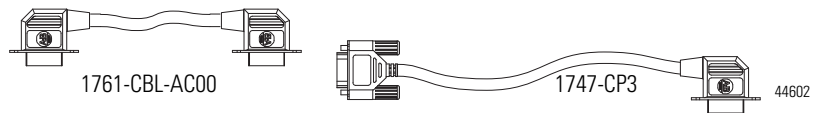

Cable	Length	Connections from	to AIC+	External Power Supply Required ⁽¹⁾	Power Selection Switch Setting ⁽¹⁾
1747-CP3 1761-CBL-AC00 ⁽¹⁾	3 m (9.8 ft) 45 cm (17.7 in.)	SLC 5/03 or SLC 5/04 processor, channel 0	port 1	yes	external
		PC COM port	port 1	yes	external
		PanelView 550 through NULL modem adapter	port 1	yes	external
		DTAM Plus DTAM™ Micro	port 1	yes	external
		Port 1 on another AIC+	port 1	yes	external
		MicroLogix 1400 ch 2	port 2	yes	external

⁽¹⁾ External power supply required unless the AIC+ is powered by the device connected to port 2, then the selection switch should be set to *cable*.

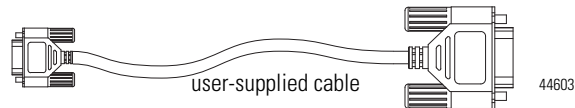

Cable	Length	Connections from	to AIC+	External Power Supply Required ⁽¹⁾	Power Selection Switch Setting ⁽¹⁾
straight 9-25 pin	—	modem or other communication device	port 1	yes	external

⁽¹⁾ External power supply required unless the AIC+ is powered by the device connected to port 2, then the selection switch should be set to *cable*.



Cable	Length	Connections from	to AIC+	External Power Supply Required ⁽¹⁾	Power Selection Switch Setting ⁽¹⁾
1761-CBL-AS03 1761-CBL-AS09	3 m (9.8 ft) 9.5 m (31.17 ft)	SLC 500 Fixed, SLC 5/01, SLC 5/02, and SLC 5/03 processors	port 3	yes	external
		PanelView 550 RJ45 port	port 3	yes	external

(1) External power supply required unless the AIC+ is powered by the device connected to port 2, then the selection switch should be set to *cable* .

1761-CBL-PM02 Series C (or equivalent) Cable Wiring Diagram

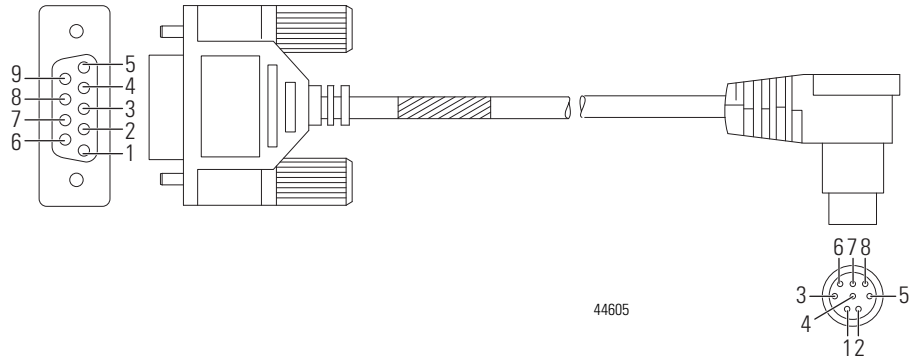

Programming Device

Controller

9-Pin D-Shell

8-Pin Mini Din

9	RI
8	CTS
7	RTS
6	DSR
5	GND
4	DTR
3	TXD
2	RXD
1	DCD

B(+)	1
GND	2
RTS	3
RXD	4
DCD	5
CTS	6
TXD	7
A(-)	8

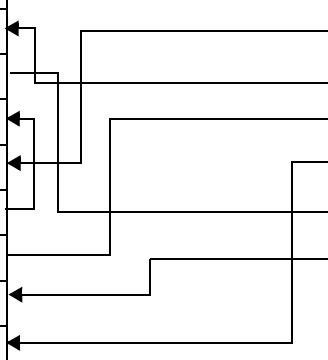

Recommended User-Supplied Components

These components can be purchased from your local electronics supplier.

User Supplied Components

Component	Recommended Model
external power supply and chassis ground	power supply rated for 20.4...28.8V dc
NULL modem adapter	standard AT
straight 9-25 pin RS-232 cable	see table below for port information if making own cables

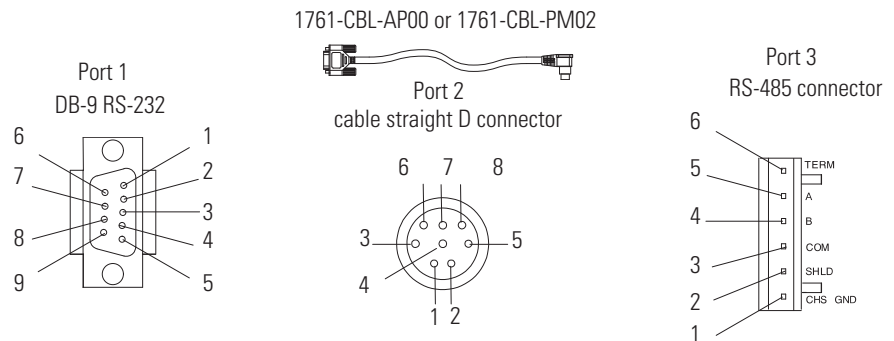

Pin	Port 1: DB-9 RS-232	Port 2 ⁽²⁾ : (1761-CBL-PM02 cable)	Port 3: RS-485 Connector
1	received line signal detector (DCD)	24V dc	chassis ground
2	received data (RxD)	ground (GND)	cable shield
3	transmitted data (TxD)	request to send (RTS)	signal ground
4	DTE ready (DTR) ⁽¹⁾	received data (RxD) ⁽³⁾	DH-485 data B
5	signal common (GND)	received line signal detector (DCD)	DH-485 data A
6	DCE ready (DSR) ⁽¹⁾	clear to send (CTS) ⁽³⁾	termination
7	request to send (RTS)	transmitted data (TxD)	not applicable
8	clear to send (CTS)	ground (GND)	not applicable
9	not applicable	not applicable	not applicable

⁽¹⁾ On port 1, pin 4 is electronically jumpered to pin 6. Whenever the AIC+ is powered on, pin 4 will match the state of pin 6.

⁽²⁾ An 8-pin mini DIN connector is used for making connections to port 2. This connector is not commercially available. If you are making a cable to connect to port 2, you must configure your cable to connect to the Allen-Bradley cable shown above.

⁽³⁾ In the 1761-CBL-PM02 cable, pins 4 and 6 are jumpered together within the DB-9 connector.

Safety Considerations

This equipment is suitable for use in Class I, Division 2, Groups A, B, C, D or non-hazardous locations only.



WARNING: EXPLOSION HAZARD

AIC+ must be operated from an external power source. This product must be installed in an enclosure. All cables connected to the product must remain in the enclosure or be protected by conduit or other means.

See Safety Considerations on page 25 for additional information.

Install and Attach the AIC+

1. Take care when installing the AIC+ in an enclosure so that the cable connecting the MicroLogix controller to the AIC+ does not interfere with the enclosure door.
2. Carefully plug the terminal block into the RS-485 port on the AIC+ you are putting on the network. Allow enough cable slack to prevent stress on the plug.
3. Provide strain relief for the Belden cable after it is wired to the terminal block. This guards against breakage of the Belden cable wires.

Powering the AIC+

MicroLogix 1000, 1200, and 1500 programmable controllers support 24V DC communication power on Channel 0. When connected to the 8 pin mini-DIN connector on the 1761-NET-AIC, 1761-NET-ENI, and the 1761-NET-ENIW, these controllers provide the power for the interface converter modules. The MicroLogix 1400 does not provide 24V DC communication power through communication ports. Instead these pins are used to provide RS-485 communications directly. Any AIC+, ENI, or ENIW not connected to a MicroLogix 1000, 1200, or 1500 controller requires a 24V DC power supply.

If both the controller and external power are connected to the AIC+, the power selection switch determines what device powers the AIC+.



ATTENTION: If you use an external power supply, it must be 24V DC (-15%/+20%). Permanent damage results if a higher voltage supply is used.

Set the DC Power Source selector switch to EXTERNAL before connecting the power supply to the AIC+. The following illustration shows where to connect external power for the AIC+.

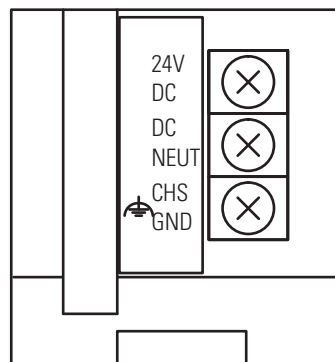

Bottom View



ATTENTION: Always connect the CHS GND (chassis ground) terminal to the nearest earth ground. This connection must be made whether or not an external 24V DC supply is used.

Power Options

Below are two options for powering the AIC+:

- Use the 24V DC user power supply built into the MicroLogix 1000, 1200, or 1500 controller. The AIC+ is powered through a hard-wired connection using a communication cable (1761-CBL-HM02, or equivalent) connected to port 2.
- Use an external DC power supply with the following specifications:
 - Operating voltage: 24V DC (-15%/+20%)
 - Output current: 150 mA minimum

Rated NEC Class 2

Make a hard-wired connection from the external supply to the screw terminals on the bottom of the AIC+.



ATTENTION: If you use an external power supply, it must be 24V DC (-15%/+20%). Permanent damage results if miswired with the wrong power source.

Connecting to Ethernet

You can connect directly a MicroLogix 1400 to an Ethernet network via the Ethernet port (Channel 1). You do not need to use an Ethernet interface card, such as the Ethernet Interface (ENI) and (ENIW), catalog number 1761-NET-ENI and 1761-NET-ENIW, to connect your MicroLogix 1400 controller to an Ethernet network. For additional information on connecting to an Ethernet network, see [Connecting to Networks via Ethernet Interface on page 383](#).

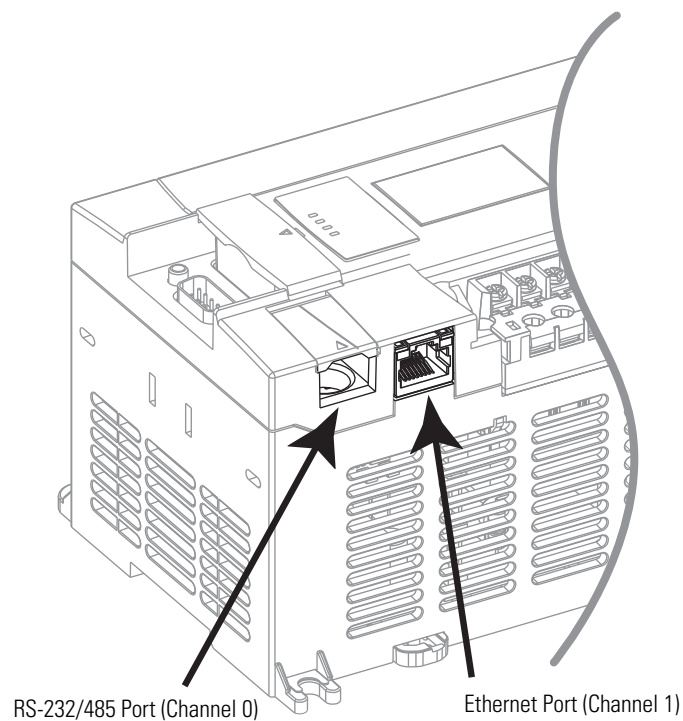

Ethernet Connections

The Ethernet connector, Channel 1, is an RJ45, 10/100Base-T connector. The pin-out for the connector is shown below.

Pin	Pin Name
1	Tx+
2	Tx-
3	Rx+
4	not used by 10/100Base-T
5	not used by 10/100Base-T
6	Rx-
7	not used by 10/100Base-T
8	not used by 10/100Base-T

End view of RJ 45 Plug

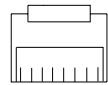

1 2 3 4 5 6 7 8

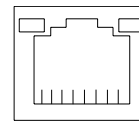

Looking into a RJ45 Jack

8 7 6 5 4 3 2 1

TIP

For more information on using ethernet cables with MicroLogix 1400, see.

Using the LCD

This chapter describes how to use the LCD and keypad on the MicroLogix 1400 controller. Topics include:

- operating principles
- I/O status display
- monitoring user defined target files
- using the mode switch
- using a user defined LCD screen
- changing key in mode
- using communications toggle functionality
- configuring Ethernet port configuration
- using trim pots
- viewing system information
- viewing fault code
- using communication EEPROM
- configuring LCD Setup
- viewing/changing protocol configuration

The LCD and keypad are shown below.

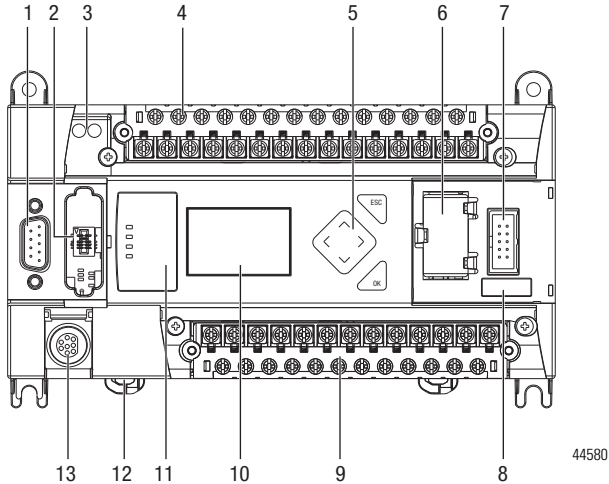

LCD and Keypad

Feature	Description
10	LCD
5	LCD Screen Keypad (ESC, OK, Up, Down, Left, and Right Buttons)

Operating Principles

Figure 34 - MicroLogix 1400 LCD Menu Structure Tree

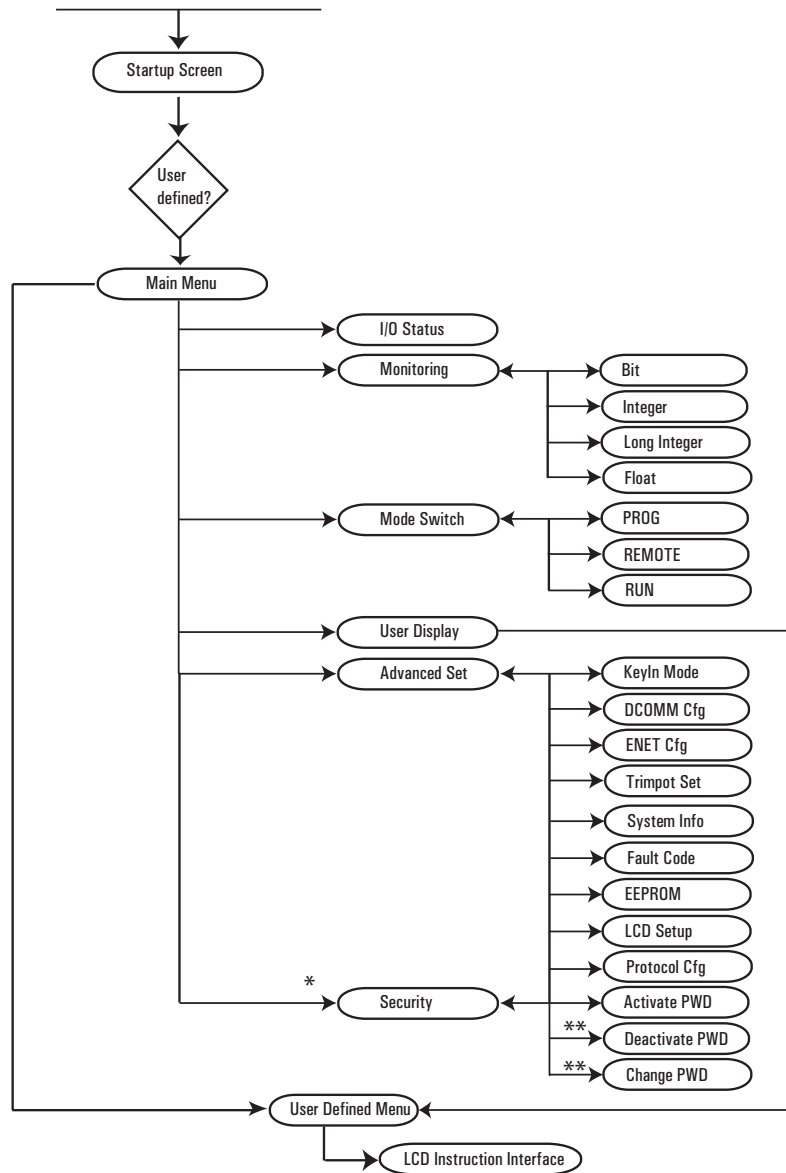

* This menu is available in firmware revision FRN 21 and higher.
 ** This menu option is displayed only when LCD Password is set.

Figure 35 - Startup Screen

The Startup screen is displayed whenever the controller is powered up.

Figure 36 - LCD Default Startup Screen

You can customize this Startup screen in your application program by defining a ASCII data file that contains the bitmap format image to display on the Startup screen and specifying the CBL element of the LCD Function File to the address of this ASCII file.

The screen shown below is an example of a customized Startup screen.

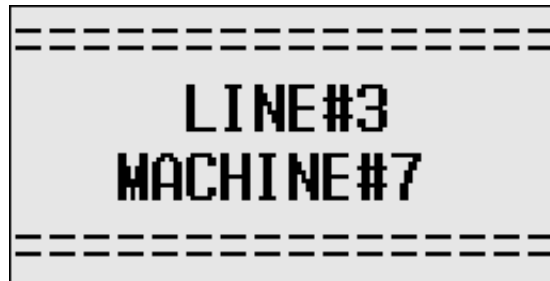

Your imported Bitmap file format should meet the following criteria:

- image resolution: 128 x 64 pixels (black/white image)
- image size: 1088 bytes
(consisting of image header = 62 bytes
+ raw image data size = 1024 bytes
+ padding data: 2 bytes)

To load a customized boot logo image to your controller, the CBL (Customized Boot Logo ASCII File) element in the LCD Function File should be configured properly. If the CBL element is set to 0 (default) or if the indexed ASCII file does not exist, the embedded default logo will be displayed.

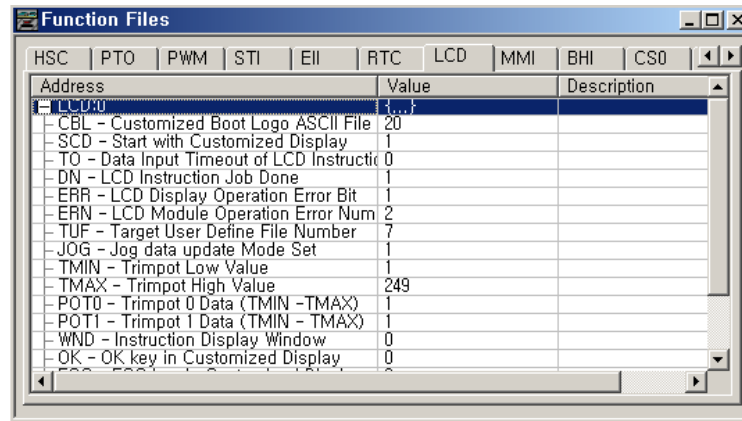

TIP Once a valid bitmap file is imported successfully, you should be able to see the data in ASCII data files.

Make sure that the second element (file size) in the first ASCII data file is 0x0440 (1088 bytes) in hexadecimal value.

After a power cycle, you should be able to see the customized boot logo on your LCD display.

For more information on how to create and use a customized Startup screen, refer to the LCD Function File described in the MicroLogix 1400 Programmable Controllers Instruction Set Reference Manual, publication [1766-RM001](#).

After the default Startup screen or your customized Startup screen is displayed for 3 seconds, either the default screen (the I/O Status screen) is displayed by default, or a user defined screen is displayed if your application uses a custom default screen.

Main Menu and Default Screen

The Main menu consists of five menu items: I/O Status, Monitoring, Mode Switch, User Display, and Advanced Set.

Figure 37 - LCD Main Menu

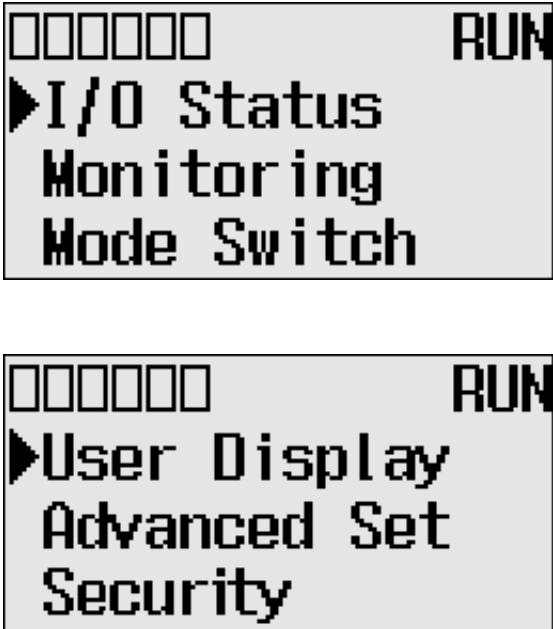

Note: The Security menu is available in firmware revision 21.000 or later.

Main Menu Items

Menu Item	Description	For details, refer to
I/O Status	Displays the I/O Status screen, which shows the I/O status of the embedded digital I/O.	I/O Status on page 109
Monitoring	Allows you to view and change the data value of a bit and an integer file.	Monitor User Defined Target Files on page 111 Monitoring Integer Files on page 116
Mode Switch	Allows you to change the mode switch selection.	Using the Mode Switch on page 128
User Display	Displays the user defined LCD screen	Using a User Defined LCD Screen on page 131
Advanced Set	Allows you to configure or view the following: <ul style="list-style-type: none"> • Change the key in mode for value entry for a trim pot. • Use the communications toggle functionality. • View and change the Ethernet network configuration. • Change the data value of trim pots. • View system information, such as OS series and firmware version. • User communication EEPROM functionality. • Change LCD contrast and backlight option. • Modbus RTU Slave Node Address 	<ul style="list-style-type: none"> • Changing Key In Mode on page 134 • Using Communications Toggle Functionality on page 136 • Viewing Ethernet Status on page 136 • Using Trim Pots on page 148 • I/O Status on page 109 • Saving/Loading Communication EEPROM on page 153 • LCD setup on page 156 • See Protocol Configuration on page 159
Security	Allows you to set, activate, deactivate and change the LCD password.	See LCD Password Setup on page 162

Figure 38 - LCD Default Screen – I/O Status Screen

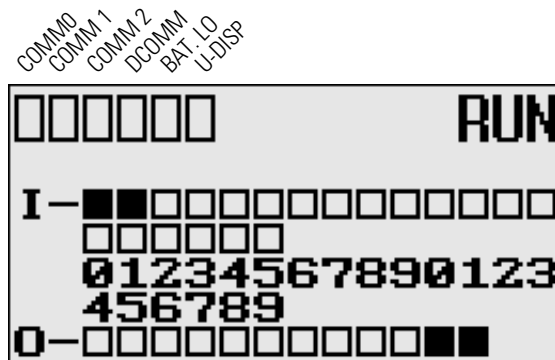

This is the default screen of the display, allowing you to monitor controller and I/O Status. For more information on the I/O Status screen, see [I/O Status on page 109](#).

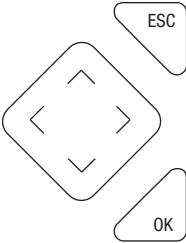

Operating Buttons



44612

Button	Function
Cursor Buttons	Move cursor
	Select menu item
	Choose file numbers, values, and so on.
OK	Next menu level, store your entry, apply the changes
ESC	Previous menu level, cancel your entry

Using Menus to Choose Values

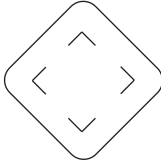
Press	To
 44613	<ul style="list-style-type: none"> Go to next menu level. Store your entry. Apply the changes.
 44614	<ul style="list-style-type: none"> Go to previous menu level. Cancel your entry since the last <i>Ok</i>. Press repeatedly to go to the main menu.
 44615	<ul style="list-style-type: none"> Change menu item. Change value. Change position.

Selecting Between Menu Items

to be 44612, 44613, 44614

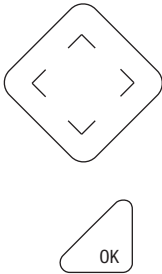

Cursor up or down

Apply or Enter

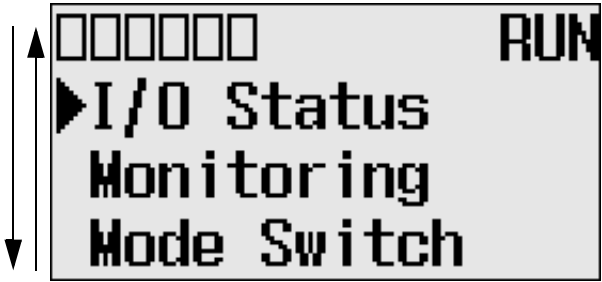

The symbol "▶" is used as the cursor.

Cursor Display

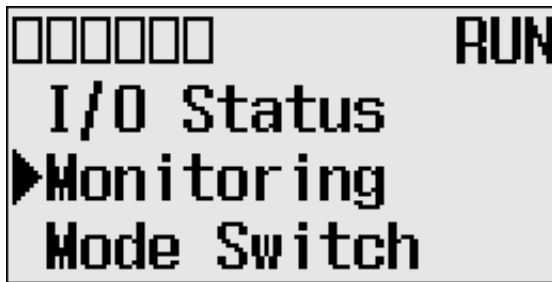

There are two different cursor types:

Selection cursor (the symbol “▶”) is displayed left to the selected item.

- Move cursor with the up/down arrows

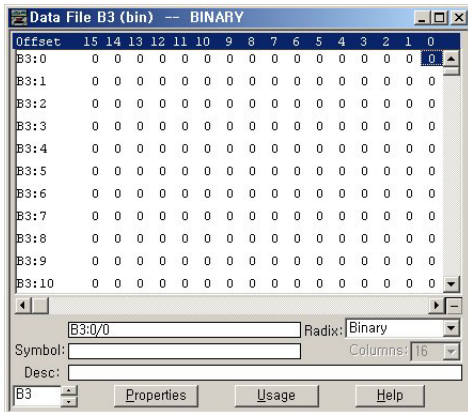

Full block navigation is shown as a flashing block:

- Change position with left/right arrows
- Change values with up/down arrows

Setting Values

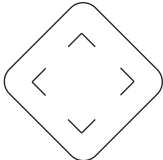

Change value = up/down arrows
 Move cursor between digits = left/right arrows



Stores Entries



Retain previous value

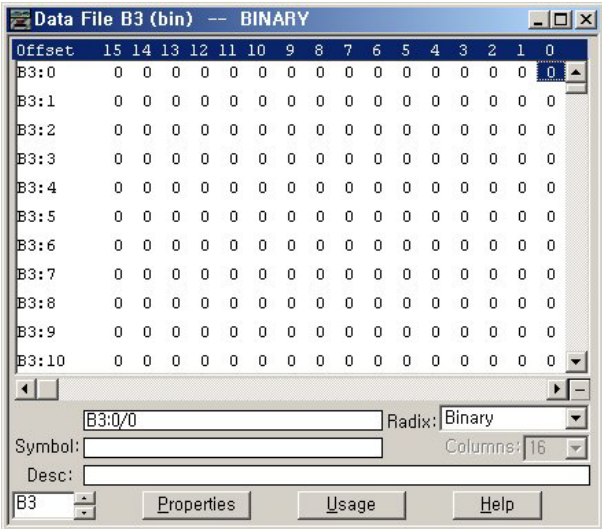

Left/right arrow moves the cursor between the digits of the value .
 Up/down arrow changes the value.
 Up arrow = increment
 Down arrow = decrement

I/O Status

The MicroLogix 1400 provides I/O status indicators on the LCD screen. You can view the status of inputs and outputs on the I/O Status screen on the LCD, as shown below. The I/O status indicators on this screen are updated every 100 ms to reflect the current I/O status in real time, regardless of controller scan time.

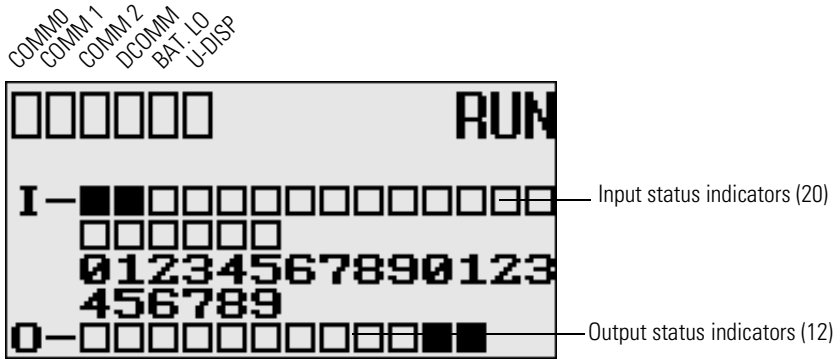

A solid rectangle is displayed when the input or output is energized. An empty rectangle is displayed when the input or output is not energized.

IMPORTANT If no user defined LCD screen is used, the I/O Status screen is displayed,

- 5 seconds after the controller has powered-up.
- When the user enters the I/O Status screen from other screen using the LCD menu. If you are at other screen and want to view I/O status, you have to enter the I/O Status screen manually using the menu. Otherwise, the current screen will be displayed continuously.

IMPORTANT If a user defined LCD screen is used, the I/O S sctatus sreen is displayed,

- When the user holds down the ESC key for more than 3 seconds.
- When time out is enabled, that is, the time out period is set to a positive value, and the time out period is passed. You can enable and disable time out and set the time out period using the TO element in the LCD Function File. For more information, refer to the LCD Function File described in the *MicroLogix 1400 Programmable Controllers Instruction Set Reference Manual*, publication [1766-RM001](#).
- If time out is disabled, that is, the time out period is set to zero (0), and a custom LCD screen is displayed, it will be displayed continuously until the user gives an input to change to other screen. For more information, see Using a User Defined LCD Screen on page 131.

Viewing I/O Status

Follow these steps to view the status of inputs and outputs on the LCD.

1. On the Main Menu screen, select I/O Status by using the Up and Down keys on the LCD keypad, as shown below.

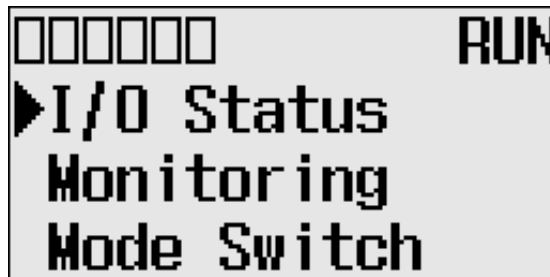

- Then, press the OK key on the LCD keypad. The I/O Status screen is displayed, as shown below.

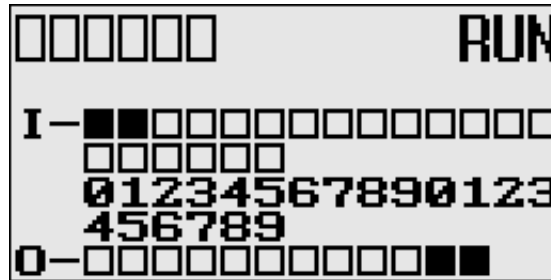

- If you have finished viewing I/O status, press the ESC key to return to the Main Menu screen, as shown in step 1.

Monitor User Defined Target Files

The LCD allows you to view and change the data values of 256 bits, words or double integers in a user defined file. You can access to this functionality via the Monitoring screen of the LCD.

To monitor the bit file on the LCD, you have to specify its file number in the Target User Defined File Number (TUF) element of the LCD Function File and download your application program to the controller. The TUF element can only be changed by a program download.

Target User Defined File Number (TUF)

Feature	Address	Data Format	Type	User Program Access
Target User Defined File Number	LCD:0.TUF	Word (int)	Control	Read Only

The value stored in the TUF element identifies the bit file with which the LCD will interface. Valid bit files are B3, and B10 through B255. When the LCD reads a valid bit file number, it can access up to 256 bits (0...255) on the LCD screen. The protection bit (LCD edit disable) in the data file properties of target bit file are used to define the read-only or read/write privileges for its file.

The file type that the LCD interfaces with is bit, integer, double integer or float file specified in the TUF element.

IMPORTANT Use your programming software to ensure that the bit file you specify in the TUF element, as well as the appropriate number of elements, exist in the MicroLogix 1400 user program.

The data protection for a file depends on the LCD edit disable setting. When LCD Edit Disable is set (1: Checked) in file properties, the corresponding data file is considered read-only by and the “Protected!” message is displayed. When

LCD Edit Disable is clear (0: Unchecked), the “UnProtected!” message is displayed and the corresponding data file is editable from the LCD keypad.

IMPORTANT Although you cannot change protected data from the LCD keypad, the control program or other communication devices do have access to this data. The Protection bit (LCD Edit Disable) only provides write protection from the LCD keypad. This does not provide any overwrite protection from ladder logic, HMI, or programming software. It is the user’s responsibility to ensure that data is not inadvertently overwritten.

TIP The LCD always starts at bit 0 of a data file. It cannot start at any other address within the file.

Monitoring a Bit File

For explanations in this section, we assume the following in the application program:

- A bit file B3, which is 256 elements long (256 words = 4096 bits), is defined with the preset data, as shown in the screen capture below.

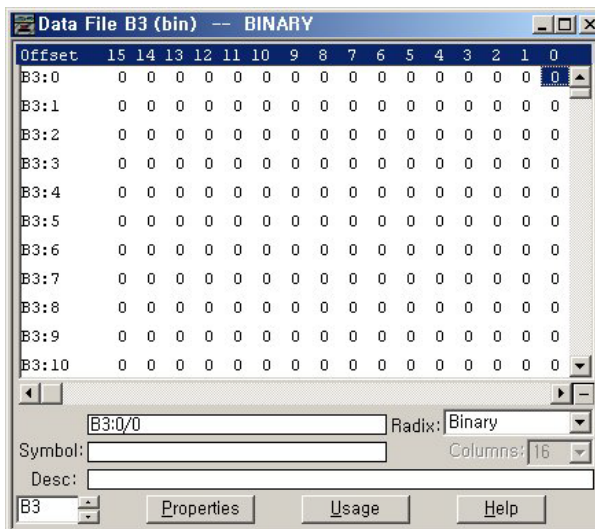

- LCD Edit Disable is set to unchecked(disable)

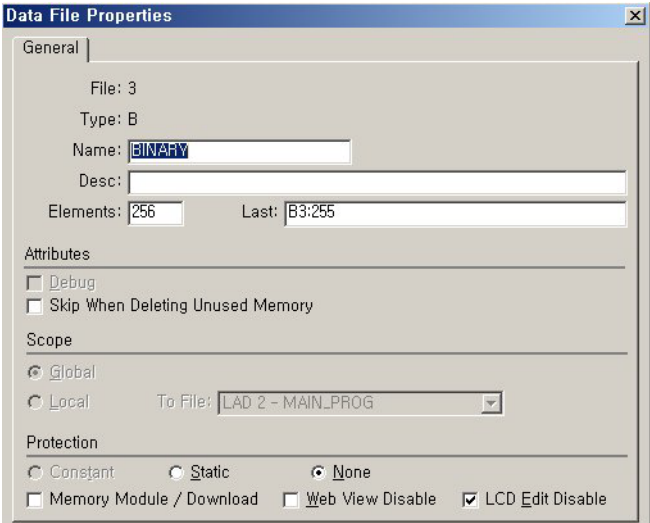

- The TUF element of the LCD Function File is set to 3 to specify the bit file B3 as the target bit file to monitor on the LCD, as shown in the screen capture below.

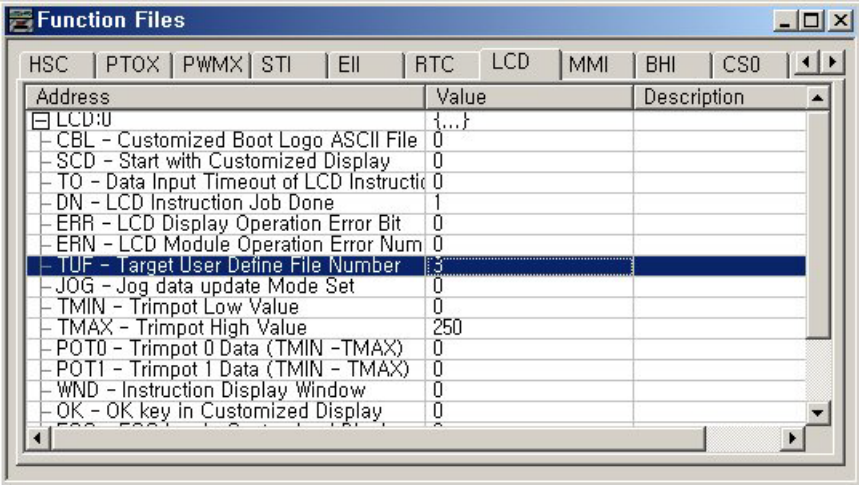

- The controller mode is set to REMOTE RUN.

Follow these steps to view and change the data values of the bit file B3.

1. On the Main Menu screen, select Monitoring by using the Up and Down keys on the LCD keypad.

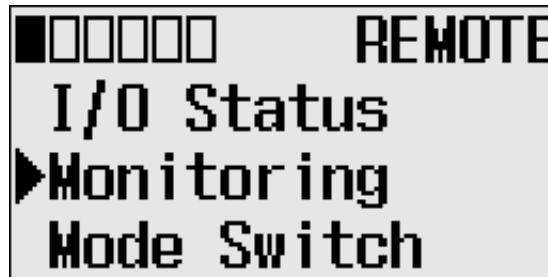

2. Press the OK key on the LCD keypad. The File Number prompt is displayed.

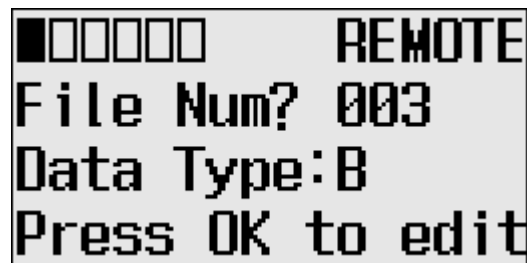

3. If number 3 is selected, as shown in step 2, press the OK key. If not selected, press the Up or Down key to select it and then press the OK key.
4. The current data value (ON) of the B3:0/0 bit is displayed, as shown below. Note that "0/0" is flashing, which means the cursor is at the target bit position.



5. We will change the data value of the B3:0/0 bit to OFF (0). First, press OK to select the displayed address and move the cursor to the data value position. Then, "ON" will flash, which means the cursor is at the data value position.
6. Press the Down key. Then, the data value will be represented as "OFF". Note that "OFF" is still flashing, which means the cursor is still at the data value position.

- Press OK to apply the changes. Then, the new value OFF (0) is applied. Note that the target bit, "0/0" in this example, is flashing. The cursor is moved automatically to the target bit position.



You can identify this change of data value is reflected to your RSLogix 500/RSLogix Micro programming software.

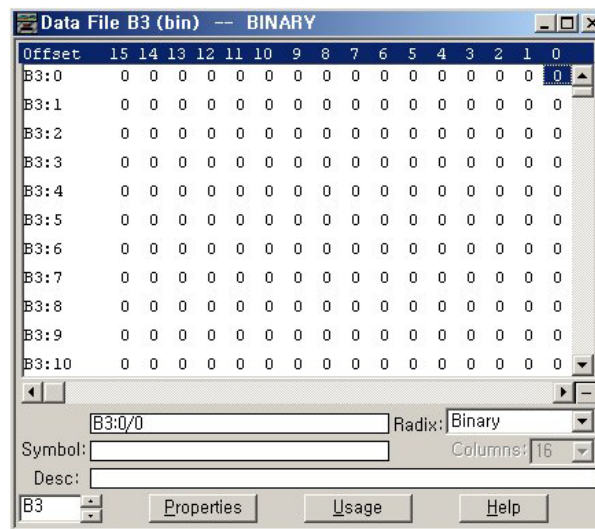

TIP

When the cursor is at the data value position, press the Down key to change the data value of a bit from ON (1) to OFF (0). Press the Up key to change from OFF (0) to ON (1).

After changing the data value of a target bit, press the OK key to apply the changes or press the ESC key to discard the changes.

8. Now, we will view an example of the data value of a protected property. If LCD Edit Disable is set to checked (enable), the “Protected!” message will be displayed and this data file cannot be edited from the LCD.

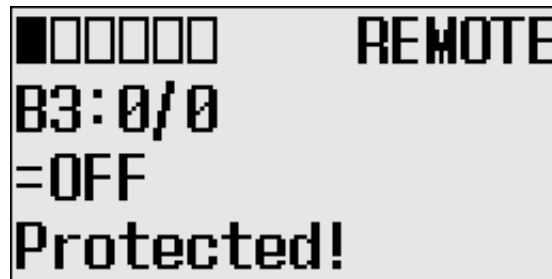

9. Try to move the cursor to the data value position by pressing the OK key. Because the B3:0/0 bit is a protected bit, you will find that the cursor does not move to the data value position.
10. Hold down the Up key until the target bit becomes “255/15”, as shown below. The maximum range of bits you can monitor with the LCD is 256 words of specified target bit file.

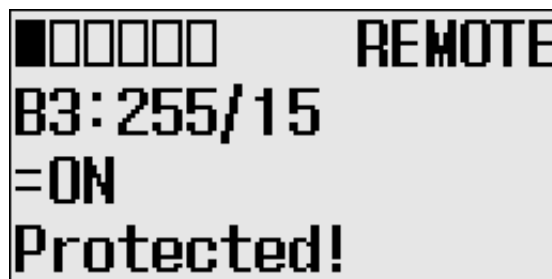

11. If you have finished monitoring the bit file, B3, press the ESC key to return to the Bit/Integer File Select screen, as shown in step 2.

Monitoring Integer Files

The LCD allows you to view and change the data value of an integer file. You can access to this functionality via the Monitoring screen of the LCD.

To monitor an integer file on the LCD, you have to specify its file number in the Target User Defined File Number (TUF) element of the LCD Function File and download your application program to the controller. The TUF element can only be changed by a program download.

The value stored in the TUF element identifies the integer file with which the LCD will interface. Valid integer files are N7, and N10 through N255. When the LCD reads a valid integer file number, it can access up to 256 bits (0...255) on the LCD screen. The protection bit (LCD edit disable) in the data file properties of the target integer file are used to define the read-only or read/write privileges for its file.

Valid file type include Bit, Integer, Double integer or Float, as specified in the TUF element.

IMPORTANT Use your programming software to ensure that the integer file you specify in the TUF element, as well as the appropriate number of elements, exists in the MicroLogix 1400 user program.

The example table below shows how the LCD uses the configuration information with integer file number 7 (LCD:0.TUF=7).

The data protection for its file depends on the setting for LCD Edit Disable. If LCD Edit Disable is set to 1 in file properties, the corresponding data file is considered read-only by the LCD and the “Protected!” message is displayed.

IMPORTANT Although you cannot change protected data from the LCD keypad, the control program or other communication devices have access to protected data. Protection bits do not provide any overwrite protection to data within the target integer file. It is entirely the user’s responsibility to ensure that data is not inadvertently overwritten.

TIP The LCD always starts at word 0 of a data file. It cannot start at any other address within the file.

For explanations in this section, we assume the following in the application program:

- An integer file N7, which is 256 elements long (256 words), is defined with the preset data, as shown in the screen capture below.

Offset	0	1	2	3	4	5	6	7	8	9
N7:0	0	0	0	0	0	0	0	0	0	0
N7:10	0	0	0	0	0	0	0	0	0	0
N7:20	0	0	0	0	0	0	0	0	0	0
N7:30	0	0	0	0	0	0	0	0	0	0
N7:40	0	0	0	0	0	0	0	0	0	0
N7:50	0	0	0	0	0	0	0	0	0	0
N7:60	0	0	0	0	0	0	0	0	0	0
N7:70	0	0	0	0	0	0	0	0	0	0
N7:80	0	0	0	0	0	0	0	0	0	0
N7:90	0	0	0	0	0	0	0	0	0	0
N7:100	0	0	0	0	0	0	0	0	0	0

Symbol: Radix: Columns:

Desc:

- The TUF element of the LCD Function File is set to 7 to specify the integer file N7 as the target integer file to monitor on the LCD, as shown in the screen capture below.

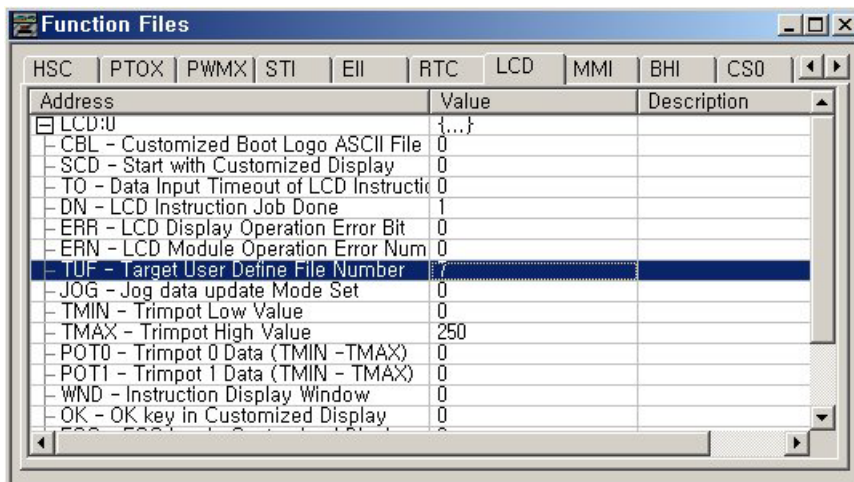

- The controller mode is set to REMOTE RUN.

Follow these steps to view and change the data values of the integer file N7.

1. On the Main Menu screen, select Monitoring by using the Up and Down keys on the LCD keypad.

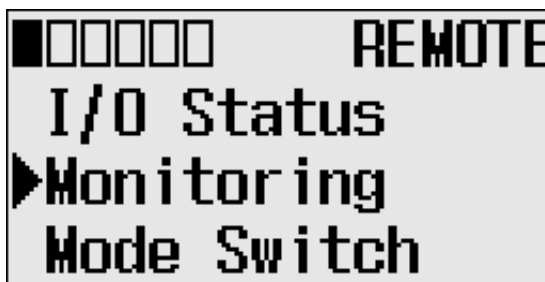

2. Press the OK key on the LCD keypad. The File Number prompt is displayed.

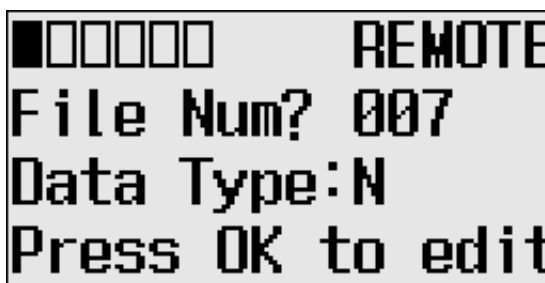

3. If Integer is selected, as shown in step 2, press the OK key. If not selected, press the Down key to select it and then press the OK key.

4. The current data value (ON) of the N7:0 word is displayed. Note that the target word “0”, which is right next to “N7:”, is flashing, which means the cursor is at the target word position.



5. We will change the data value of the N7:0 word to the negative decimal value -1300. First, press OK to move the cursor to the data value position. Then, the last digit of “+00000” will be flashing, which means the cursor is at the data value position.
6. Press the Left key twice. Then, the cursor will position at the third digit. Press the Up key three times to change the third digit to 3.



7. Press the Left key once. Then, press the Up key once. The second digit will change to “1”. Note that “1” is still flashing, which means the cursor is still at the data value position.



8. Press the Left key once. Then, press the Down key once. The sign digit will change to “-”, as shown below. Note that “-” is still flashing, which means the cursor is still at the data value position.



9. Press OK to apply the changes. Then, the new value -1300 is applied. Note that the target word “0”, which is right next to “N7:”, is flashing. The cursor is moved automatically to the target word position.

You can identify this change of data value is reflected to your RSLogix 500/RSLogix Micro programming software, as shown below.

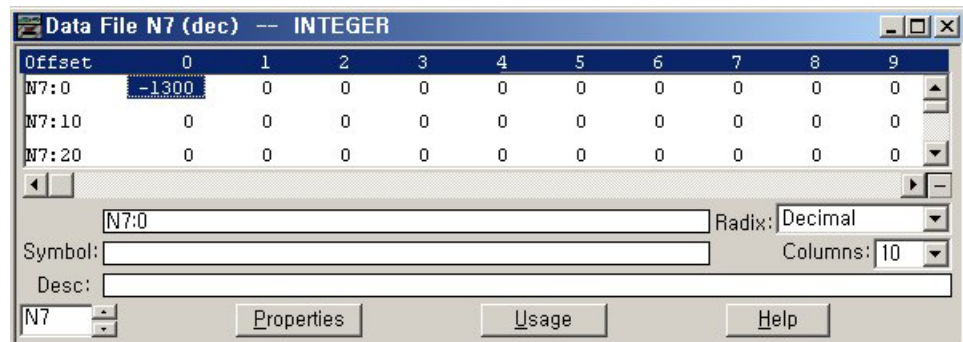

TIP After changing the data value of a target word, press the OK key to apply the changes or press the ESC key to discard the changes.

10. Now, we will view an example of the data value of a protected property. If LCD Edit Disable is set to checked (enable), the “Protected!” message will be displayed and this data file cannot be edited by the LCD.

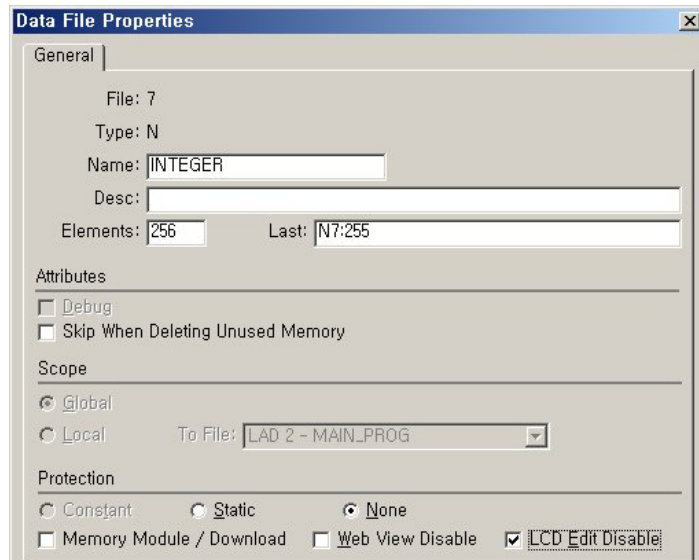

11. Try to move the cursor to the data value position by pressing the OK key. Because the N7:0 word is protected, you will find that the cursor even does not move to the data value position.

IMPORTANT The maximum range of words you can monitor with the Integer File Monitoring functionality on the LCD is the first 256 words (0...255) of the target integer file.

12. If you have finished monitoring the integer file N7, press the ESC key to return to the Main Menu screen, as shown in step 2.

Monitoring Double Integer files

The LCD allows you to view and change the data value of a double integer file. You can access to this functionality via the Monitoring screen of the LCD.

To monitor a double integer file on the LCD, you have to specify its file number in the Target User Defined File Number (TUF) element of the LCD Function

File and download your application program to the controller. The TUF element can only be changed by a program download.

The value stored in the TUF element identifies the double integer file with which the LCD will interface. Valid double integer files are L9, and L10 through L255. When the LCD reads a valid double integer file number, it can access up to 256 words (0 to 255) on the LCD screen. The protection bit (LCD edit disable) in the data file properties of target integer file are used to define the read-only or read/write privileges for its file.

Valid file type include Bit, Integer, Double integer or Float, as specified in the TUF element.

The data protection for its file depends on the setting for LCD Edit Disable. If LCD Edit Disable is set to 1 in file properties, the corresponding data file is considered read-only by the LCD and the "Protected!" message is displayed.

IMPORTANT

Although you cannot change protected data from the LCD keypad, the control program or other communication devices do have access to this data. The Protection bit (LCD Edit Disable) only provides write protection from the LCD keypad. This does not provide any overwrite protection from ladder logic, HMI, or programming software. It is the user's responsibility to ensure that data is not inadvertently overwritten.

For explanations in this section, we assume the following in the application program:

- A bit file L9, which is 256 elements long (256 words), is defined with the preset data, as shown in the screen capture below.

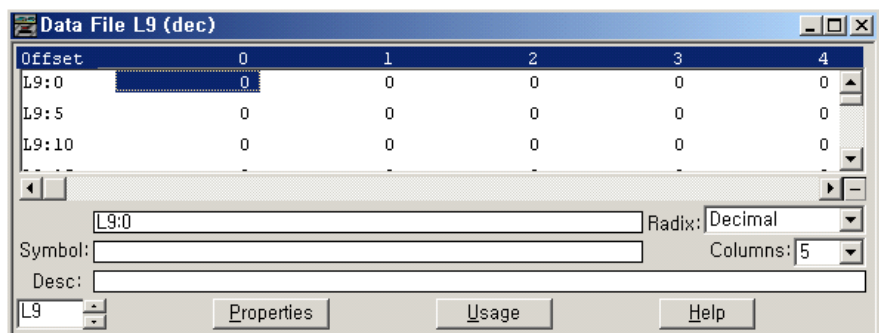

- LCD Edit Disable is set to unchecked(disable)

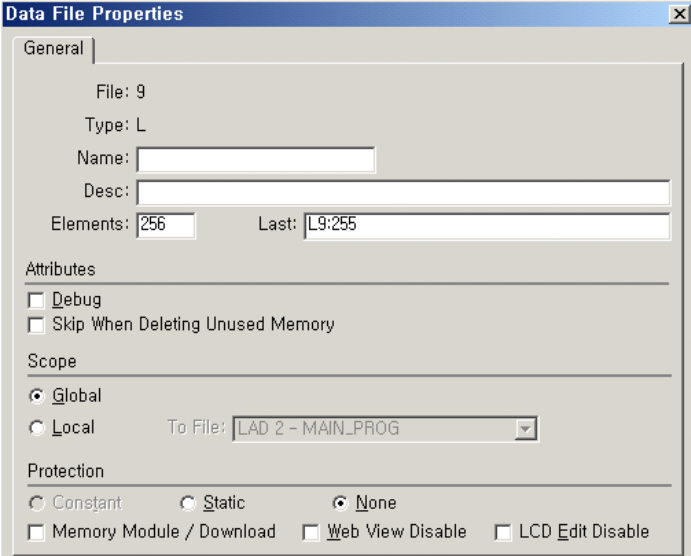

- The TUF element of the LCD Function File is set to 9 to specify the integer file L9 as the target file to monitor on the LCD, as shown in the screen capture below.
The controller mode is set to REMOTE RUN.

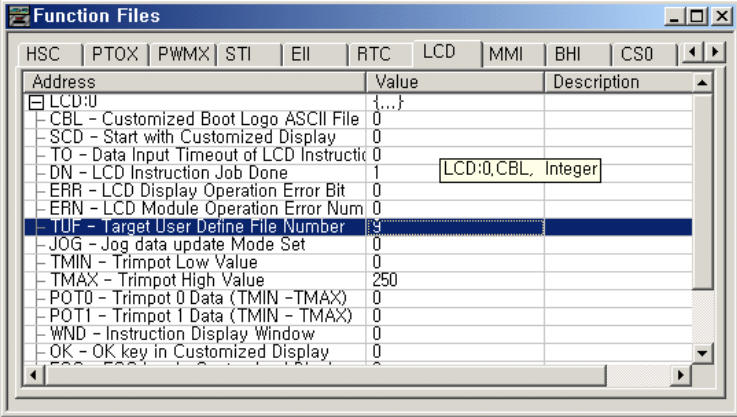

Follow these steps to view and change the data values of the double integer file L9.

1. On the Main Menu screen, select Monitoring by using the Up and Down keys on the LCD keypad.

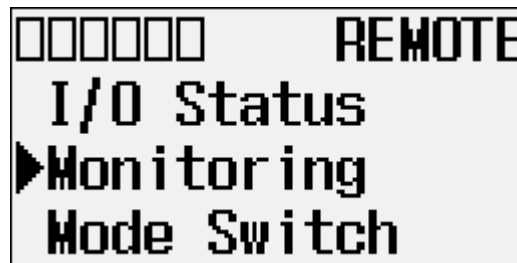

2. Then, press the OK key on the LCD keypad. The File Number prompt is displayed.

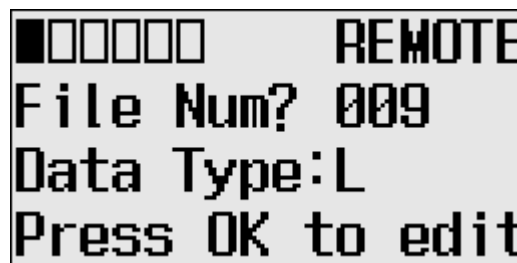

3. If Integer is selected, as shown in step 2, press the OK key. If not selected, press the Down key to select it and then press the OK key.
4. The current data value (ON) of the L9:0 word is displayed. Note that the target word "0", which is at the right "L9:", is flashing, which means the cursor is at the target word position.



5. We will change the data value of the L9:0 word to the negative decimal value -1300. First, press OK to move the cursor to the data value position. Then, the last digit of "+0000000000" will be flashing, which means the cursor is at the data value position.

6. Press the Left key twice. Then, the cursor will position at the third digit. Press the Up key three times to change the third digit to 3.



7. Press the Left key once. Then, press the Up key once. The second digit will change to "1". Note that "1" is still flashing, which means the cursor is still at the data value position.
8. Press the Left key once. Then, press the Down key once. The sign digit will change to "-", as shown below. Note that "-" is still flashing, which means the cursor is still at the data value position.



9. Press OK to apply the changes. The new value -1300 is applied. Note that the target word "0", which is to the right of "L9:", is flashing. The cursor is moved automatically to the target word position.



- You can identify this change of data value is reflected to your RSLogix 500/RSLogix Micro programming software.

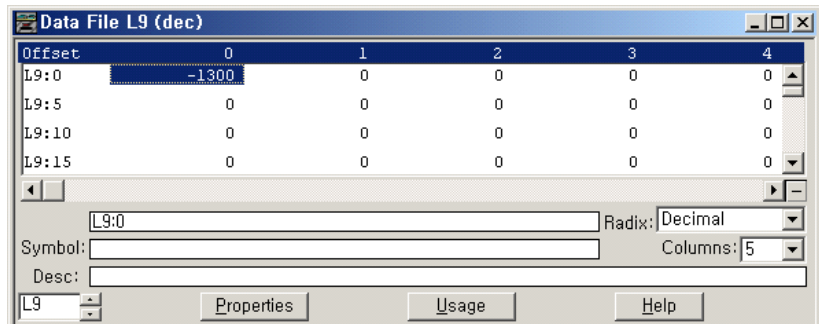

TIP After changing the data value of a target double word, press the OK key to apply the changes or press the ESC key to discard the changes.

- Now, we will view an example of the data value of a protected property. If LCD Edit Disable is set to checked (enable), the "Protected!" message will be displayed and this data file cannot be edited by the LCD.

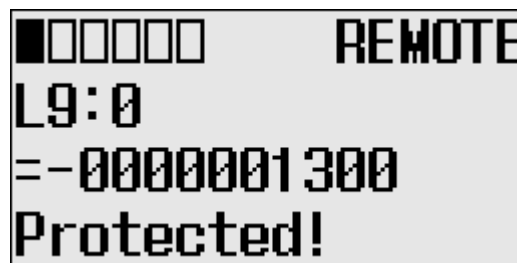
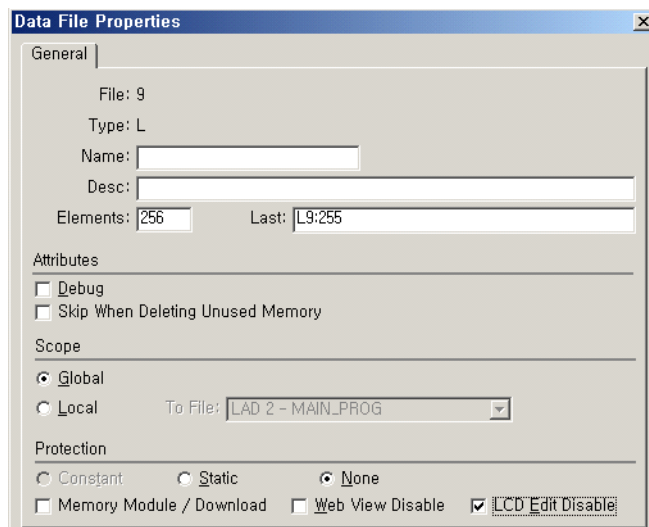

- Try to move the cursor to the data value position by pressing the OK key. Because this double integer file is protected, you will find that the cursor even does not move to the data value position.

13. If you have finished monitoring the double integer file, L9, press the ESC key to return to the File Number question screen, as shown in step 2.

Monitor Floating point Files

In this section, this assumption regarding the application program is made:

- The TUF element of the LCD Function File is set to 8. This specifies the floating point file F8 as the target file to monitor via the LCD.

Most of the steps outlined in this section are similar to those found in [Monitoring Double Integer files on page 121](#). However, you will not be able to edit floating point files from the LCD.



The Protected! message is displayed on the LCD for floating point files.

- TIP** MicroLogix 1400 Series A controllers display an "Unprotected!" message but you will not be able to edit the corresponding data file.

Monitor System Status Files

In this section, this assumption regarding the application program is made:

- The TUF element of the LCD Function File is set to 2. This specifies the system status file S2 as the target file to monitor via the LCD.

Controller Modes

The table below shows the possible controller modes when the mode switch positions at PROGRAM, REMOTE, or RUN. For example, if the Mode Switch is at RUN and you want to test a control program with running it for a single scan, you have to first change mode switch position to REMOTE before you run the control program in the remote test single scan mode with your RSLogix 500/RSLogix Micro programming software.

Possible Controller Modes by Mode Switch Position

When the Mode Switch Positions at	Possible Controller Modes are
PROGRAM	download in progress
	program mode
	suspend mode (operation halted by execution of the SUS instruction)
REMOTE	remote download in progress
	remote program mode
	remote suspend mode (operation halted by execution of the SUS instruction)
	remote run mode
	remote test continuous mode
	remote test single scan mode
RUN	run mode

Changing Mode Switch Position

Mode Switch position can be changed at two different times using LCD keypad. One is when the controller is powered up, and the other is while the controller is powered on.

Mode Switch position can be set to either PROG or RUN when the controller is powered up. This allows the controller operation which is different from the previous mode, that is, any program under RUN before can be stopped or any new program can be run when the controller is powered up.

- How to forcibly set Mode Switch to RUN when the controller is powered up:

Press OK key for 5 seconds when the controller is powered up. The following LCD screen appears if it's successfully done.

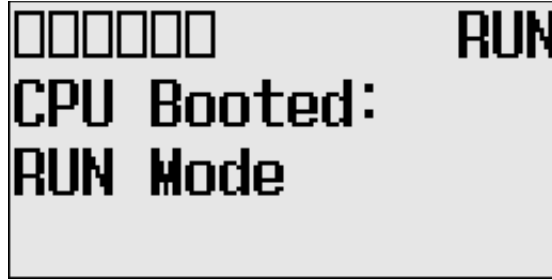

- How to forcibly set Mode Switch to PROG when the controller is powered up:

Press ESC key for 5 seconds when the controller is powered up. The following LCD screen appears if it's successfully done.



Note that I/O output status may be changed for some programs.

While the controller is powered on, follow these steps to change the position of the Mode Switch.

1. On the Main Menu screen, select Mode Switch by using the Up and Down keys on the LCD keypad.

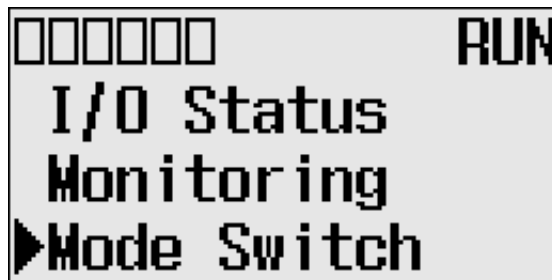

2. Then, press the OK key on the LCD keypad. The Mode Switch screen is displayed, as shown below.

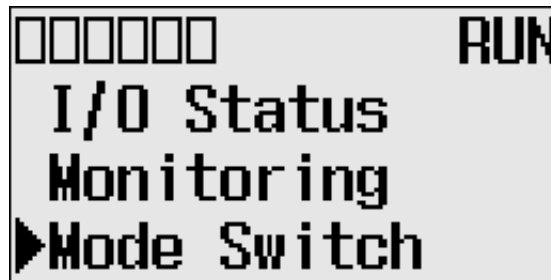

The arrow indicates current Mode Switch position.

3. When the Up or Down key is pressed, the mode indicated by the arrow starts to blink if the mode is different from the current mode of controller. Press the OK key to set the controller to the mode indicated by the arrow.
4. If you have finished changing mode switch position, press the ESC key to return to the Main Menu screen, as shown in step 1.

Using a User Defined LCD Screen

The MicroLogix 1400 controller allows you to use user defined LCD screens instead of the default built-in screens.

To use a user defined screen, you need to create a group of appropriate instructions using the LCD instruction in your application program. For more information on how to create a user defined LCD screen, refer to the MicroLogix 1400 Programmable Controllers Instruction Set Reference Manual, publication [1766-RM001](#).

By using the User Display menu item, you can change from the default built-in screens to a user defined screen and back on the LCD.

User Defined LCD Screen

Follow these steps to display the user defined screen implemented in your application program.

1. On the Main Menu screen, select User Display by using the Up and Down keys on the LCD keypad, as shown below. If the menu items shown in the figure below are not displayed on the Main Menu screen, you need to scroll down the screen by pressing the Down key.



Note: The Security menu is available in firmware revision 21.000 or later.

2. Then, press the OK key on the LCD keypad.

If no user defined screen is used in your application program, the screen is displayed, as shown below.



Note that the U-DISP indicator on the top of the LCD is displayed in solid rectangle. It means the LCD is in User Defined LCD mode.

If a user defined screen is used in your application program, the LCD screen is displayed, as shown below, according to the specific instructions used in your program.

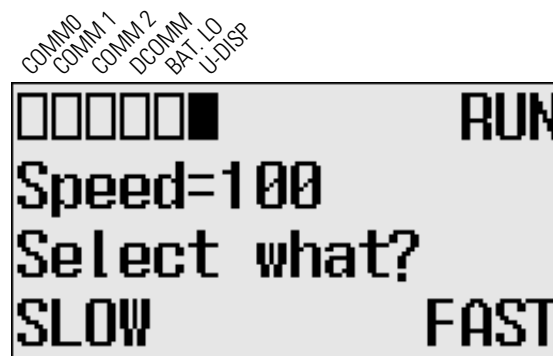

3. Hold down the ESC key **more than 3 seconds** to return to the Main Menu screen, as shown below.

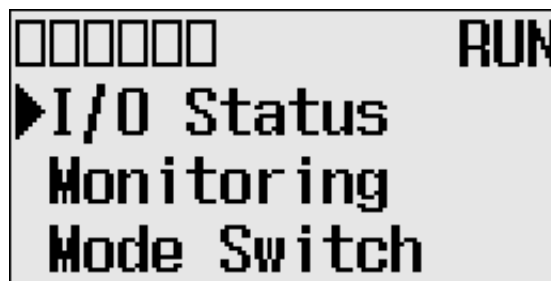

Configuring Advanced Settings

With the Advanced Set menu, which is a sub-menu under the main menu of the LCD, you can use the following features:

- changing Key In mode
- using communications toggle functionality
- configuring Ethernet Network Configuration
- using trim pots
- viewing system information
- viewing fault code
- saving/loading Communication EEPROM
- changing LCD contrast and backlight
- viewing/changing the Modbus RTU Slave Node address

You can access to the Advanced Set Menu screen, as shown below, by selecting Advanced Set on the Main Menu screen.

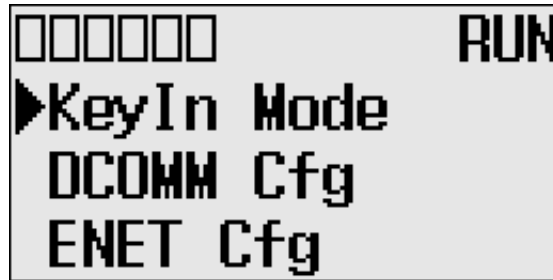

Changing Key In Mode

Key In Modes

There are two Key In modes, Continuous and Discrete.

TIP

The Key In mode has an effect only when you change the data value of a trim pot on a trim pot screen, either Trim Pot 0 or Trim Pot 1 screen. For more information on how to change the data value of a trim pot, see Changing Data Value of a Trim Pot on page 149.

The current Key In mode determines how the value changes are applied when you press the Up and Down keys to change the data value for a trim pot. When set to Continuous, the changes are applied immediately whenever you press the Up and Down keys. When set to Discrete, the changes are applied only when you press the OK key after you have changed the value using the Up and Down keys.

By using the Key In Mode screen, as shown below, you can change the Key In mode to use.



Changing Key In Mode

Follow these steps to change the current Key In mode.

1. On the Main Menu screen, select Advance Set by using the Up and Down keys on the LCD keypad. If the menu items shown in the figure below are not displayed on the Main Menu screen, you need to scroll down the screen by pressing the Down key.



Note: The Security menu is available in firmware revision 21.000 or later.

2. Then, press the OK key on the LCD keypad. The Advanced Settings Menu screen is displayed.

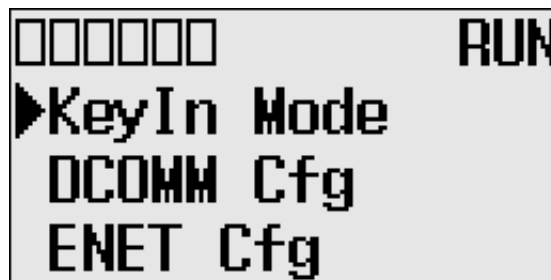

3. Select KeyIn Mode using the Up and Down keys, and then press the OK key.
4. The Key In Mode screen is displayed. The current mode, Continuous in this example, is selected marked up with the symbol "▶".



5. Press the Up or Down key to select the different mode, Discrete in this example. Press the OK key.



6. The Key In Mode Change Notification screen is displayed, as shown below.

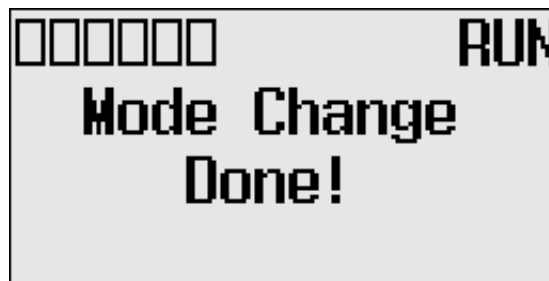

7. Press the ESC key to return to the Advanced Set Menu screen, as shown in step 2.

Using Communications Toggle Functionality

The MicroLogix 1400 provides the Communications Toggle Functionality, which allows you to change from the user-defined communication configuration to the default communications mode and back to the user defined communication configuration on Channel 0. See [Using the Communications Toggle Functionality on page 76](#) for more information on this feature.

Ethernet Network Configuration

Viewing Ethernet Status

The Ethernet configuration screen of the LCD displays the MAC and IP addresses assigned to the controller.

Follow these steps to view the Ethernet configuration for your controller.

1. On the Main Menu screen, select Advanced Set by using the Up and Down keys on the LCD keypad, as shown below. If the menu items shown in the figure below are not displayed on the Main Menu screen, you need to scroll down the screen by pressing the Down key.



Note: The Security menu is available in firmware revision 21.000 or later.

2. Press the OK key on the LCD keypad. The Advanced Set Menu screen is displayed, as shown below.

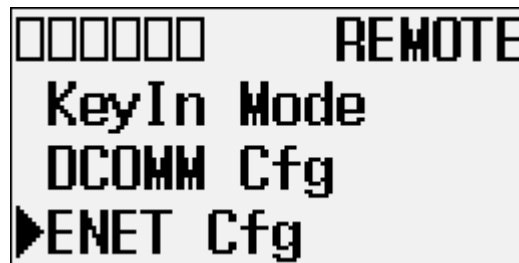

3. If ENET Cfg is selected, press the OK key. Otherwise, select ENET Cfg using the Up and Down keys, and then press the OK key.
4. The Ethernet Configuration screen is displayed. Press the OK key on the LCD Status menu.

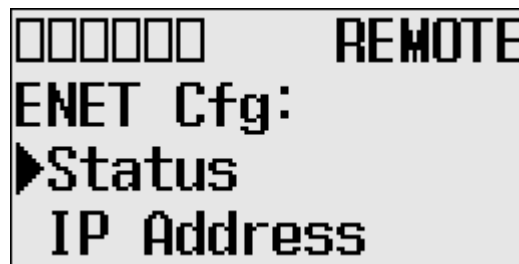

- When an IP address is not yet assigned to your controller, only the MAC address that is assigned to your controller, represented as XXXXXXXXXXXXX below, is displayed. A MAC address is a 12-digit hexadecimal number. Your controller ships with a unique MAC address assigned in the factory. You can identify the MAC address of your controller by opening the expansion module cover on your controller.

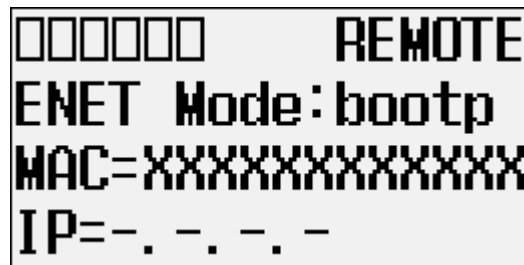

- When an IP address is assigned to your controller, both the MAC and IP addresses of your controller are displayed, as shown below. In this example, the MAC address is represented as XXXXXXXXXXXXX. The IP address is represented as xxx.xxx.xxx.xxx, where each xxx is a decimal number between 0...255.

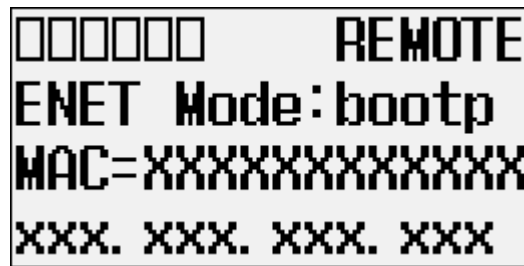

- Press the ESC key to return to the Advanced Set Menu screen, as shown in step 2.

Configuring the IP Address

The IP Address screen of the LCD displays Ethernet network configuration assigned to the controller.

Follow these steps to edit the Ethernet network configuration for your controller.

1. On the Main Menu screen, select Advanced Set by using the Up and Down keys on the LCD keypad, as shown below. If the menu items shown in the figure below are not displayed on the Main Menu screen, you need to scroll down the screen by pressing the Down key.



Note: The Security menu is available in firmware revision 21.000 or later.

2. Press the OK key on the LCD keypad. The Advanced Settings Menu screen is displayed, as shown below. If ENET Cfg is selected, press the OK key. Otherwise, select ENET Cfg using the Up and Down keys, and then press the OK key.

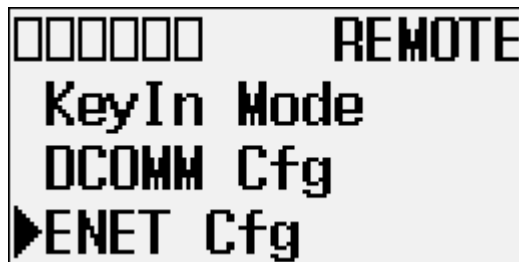

3. If IP Address is selected, press the OK key. If not, select IP Address using the Up and Down keys, and then press the OK key.

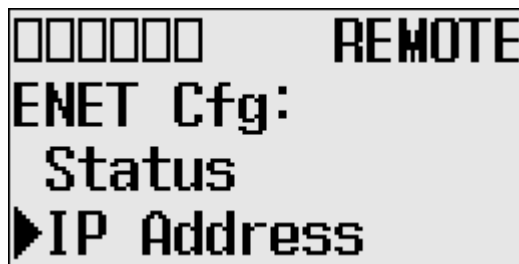

4. The password screen displays. Press Up, Down, Left and Right keys to enter the Master password up to a maximum of 10 digits. In this example, the current Master password is allocated as "1234".

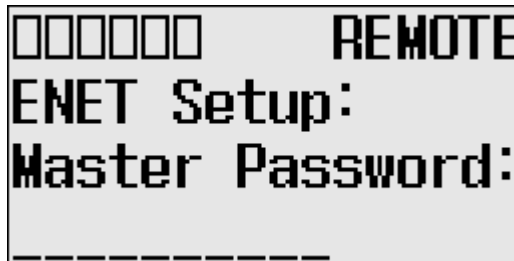

Note: For firmware revisions 21.000 or later the LCD password screen displays.



5. After entering the Master password, press the OK key on the LCD keypad.

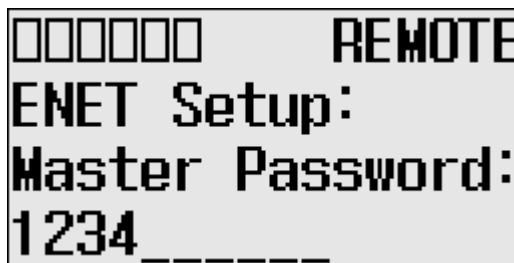

Note: For firmware revisions 21.000 or later, press the OK key on the LCD password screen.



6. If the Master password is incorrect, an error message will be displayed.

A monochrome LCD screen with a black border. The text is displayed in a fixed-width font. The top line shows six empty square boxes followed by the word 'REMOTE'. The second line reads 'ENET Setup:'. The third line reads 'Password Wrong!'.

7. If the password is correct, the Ethernet network type screen is displayed as below. Press Up or Down key to select the appropriate Ethernet mode.

A monochrome LCD screen with a black border. The text is displayed in a fixed-width font. The top line shows six empty square boxes followed by the word 'REMOTE'. The second line reads 'ETH Mode: bootp' followed by a small diamond-shaped cursor. The third line reads 'Press [U/D] key'.

If you press the OK key at the static mode, the IP address flashes.

A monochrome LCD screen with a black border. The text is displayed in a fixed-width font. The top line shows six empty square boxes followed by the word 'REMOTE'. The second line reads 'ENET Mode: static'. The third line reads 'IP address'. The fourth line reads '192.168.100.201'.

8. After configuring the IP address, press the OK key. The Subnet Mask screen is displayed.

A monochrome LCD screen with a black border. The text is displayed in a fixed-width font. The top line shows six empty square boxes followed by the word 'REMOTE'. The second line reads 'ENET Mode: static'. The third line reads 'Subnet Mask'. The fourth line reads '255.255.255.000'.

9. After configuring the Subnet Mask, press the OK key. The Gateway address is displayed.

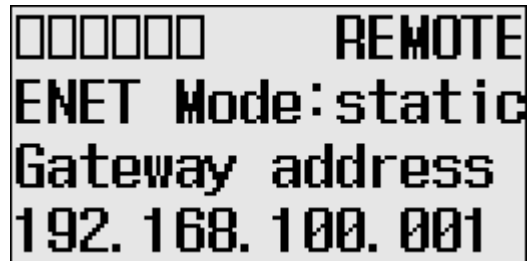

10. After configuring the Gateway address, press the OK key. The Primary DNS is displayed.

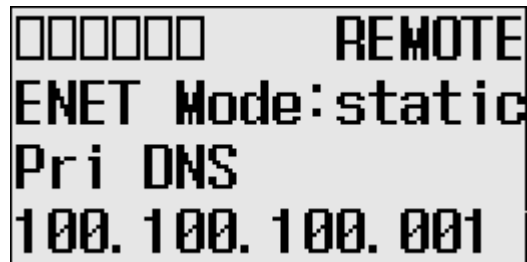

11. After configuring the Primary DNS, press the OK key. The Secondary DNS is displayed.

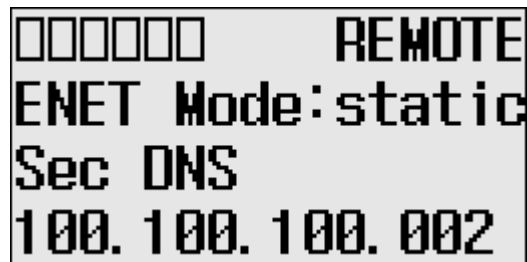

TIP To exit the Network configuration Menu, press the ESC key on the LCD keypad at any time.

Configuring the Ethernet Port

The Port Settings screen of the LCD displays the Ethernet port settings assigned to the controller.

Follow these steps to edit the Ethernet port settings for your controller.

1. On the Main Menu screen, select Advanced Set by using the Up and Down keys on the LCD keypad. If the menu items shown in the figure below are not displayed on the Main Menu screen, you need to scroll down the screen by pressing the Down key.



Note: The Security menu is available in firmware revision FRN 21 and higher.

2. Press the OK key on the LCD keypad. The Advanced Settings Menu screen is displayed.

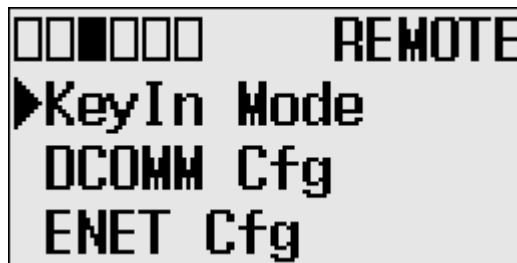

3. If ENET Cfg is selected, press the OK key. If not, select ENET Cfg using the Up and Down keys, and then press the OK key.

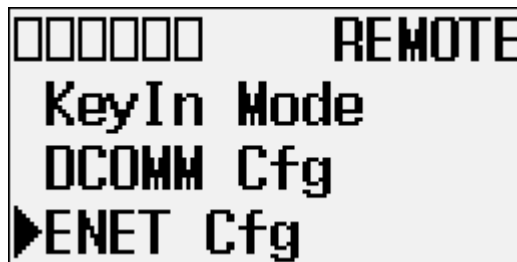

4. If Port Setting is selected, press the OK key. If not, select Port Setting using the Up and Down keys, and then press the OK key.

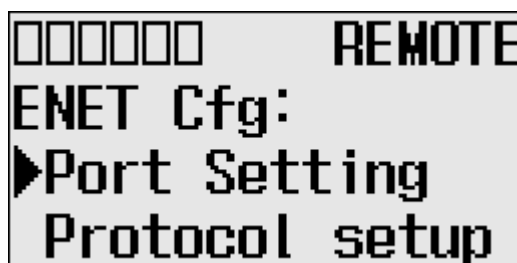

5. The password screen displays. Press Up, Down, Left and Right keys to enter Master password with maximum 10 digits. In this example, the current Master password is allocated as "1234".



Note: For firmware revisions 21.000 or later the LCD password screen displays.



After entering the Master password, press the OK key on the LCD keypad.

6. If the Master password is correct, the last configuration is displayed. In this example, the auto negotiation function is enabled and the 10/100Mbps link configuration is shown.

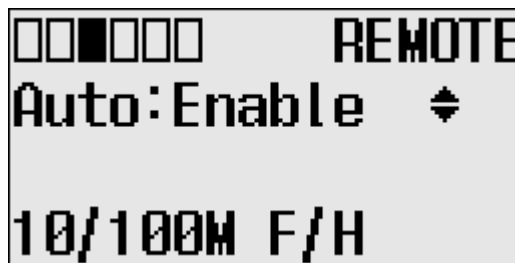

7. Press Up and Down key to select auto disable menu, then press the OK key. The fourth line on the LCD flashes. Press the Up and Down keys to configure the Ethernet port to 100Mbps Full-duplex forced.

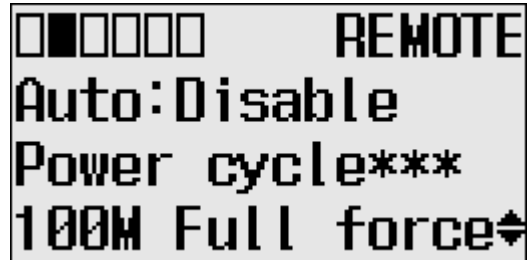

TIP Any change to this feature's configuration does not take effect until after the next power cycle.

Configuring Ethernet Protocol Setup

The Ethernet Protocol Setup screen of the LCD displays Ethernet Protocol settings assigned to the controller.

Follow these steps to edit the Ethernet Protocol settings for your controller.

1. On the Main Menu screen, select Advanced Set by using the Up and Down keys on the LCD keypad, as shown below. If the menu items shown in the figure below are not displayed on the Main Menu screen, you need to scroll down the screen by pressing the Down key.



Note: The Security menu is available in firmware revision 21.000 or later.

2. Press the OK key on the LCD keypad. The Advanced Settings Menu screen is displayed, as shown below.

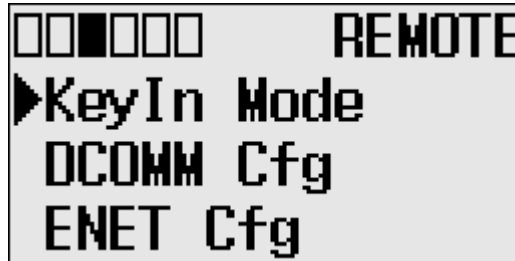

3. If ENET Cfg is selected, press the OK key. If not, select ENET Cfg using the Up and Down keys, and then press the OK key.

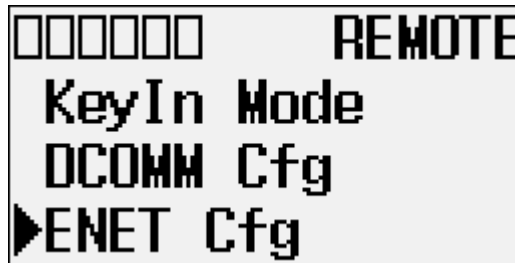

4. If Protocol setup is selected, press the OK key. If not, select Protocol setup using the Up and Down keys, and then press the OK key.

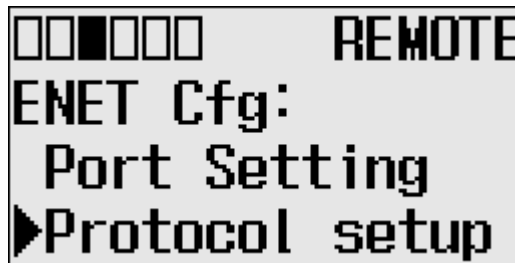

5. The password screen displays. Press Up, Down, Left and Right keys to enter a Master password up to a maximum of 10 digits. In this example, the current Master password is allocated as "1234".



Note: For firmware revisions 21.000 or later the LCD password screen displays.



After entering the Master password, press the OK key on the LCD keypad.

- 6. The following menu displays.

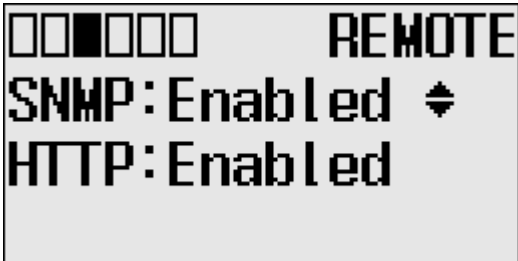

If you want to change the SNMP setting, press the Up or Down key and press the OK key to apply the change.

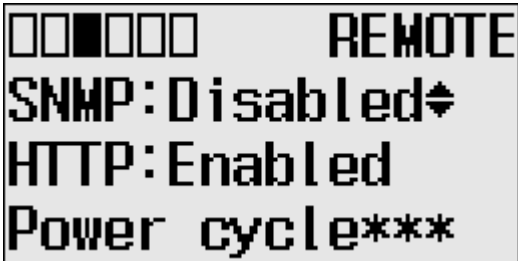

- To change the HTTP setting, press the Up or Down key and press the OK key to apply the change.

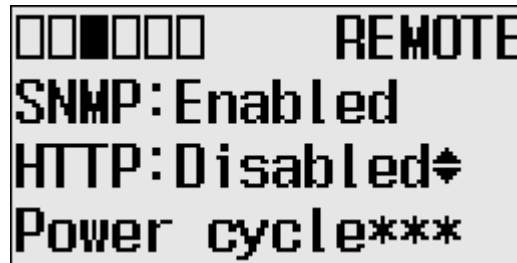
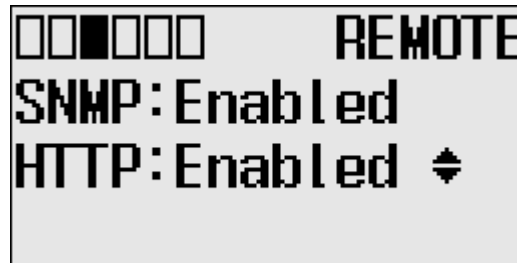

TIP To exit the Protocol Setup Menu, press the ESC key on the LCD keypad at any time.

Using Trim Pots

Trim Pot Operation

The MicroLogix 1400 controller provides two trimming potentiometers (trim pots, POT0 and POT1) which allow modification of integer data within the controller. The data value of each trim pot can be used throughout the control program for timers, counters, analog presets, depending upon the requirements of the application.

You can change the data value of each trim pot using the trim pot screens provided by the LCD. To access to the Trim Pot Set screen, which is the top screen for the trim pot functionality, select trim pot Set on the LCD default menu screen, as shown below, and press the OK key on the LCD keypad.

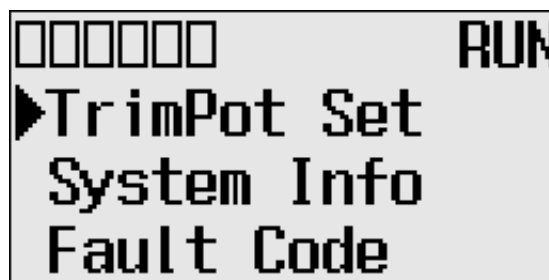

Trim pot data is updated continuously whenever the controller is powered-up.

Changing Data Value of a Trim Pot

Follow these steps to change the data value of a trim pot, either POT0 or POT1.

1. On the Main Menu screen, select trim pot Set by using the Up and Down keys on the LCD keypad.

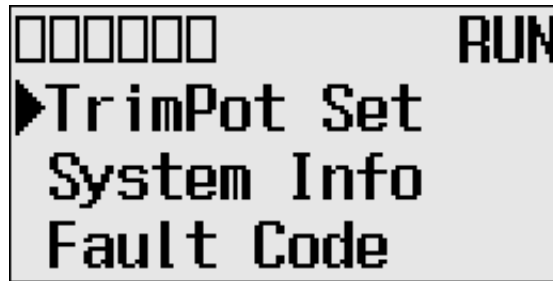

2. Then, press the OK key on the LCD keypad. The Trim Pot Select screen is displayed, as shown below.

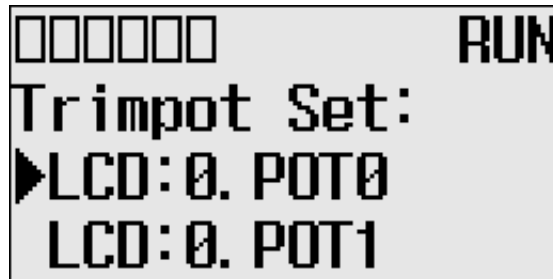

The last trim pot whose data value you changed is selected by default. If you are accessing to this screen for the first time, POT0 is selected by default.

3. Select a trim pot, either POT0 or POT1, whose data value you want to change using the Up and Down keys on the LCD keypad. In this example, we will select POT0.
4. Then, press the OK key on the LCD keypad. The Trim Pot 0 screen is displayed, as shown below.

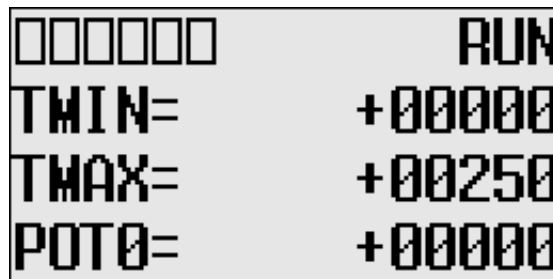

TMIN and TMAX indicate the range of data value for the trim pots, both POT0 and POT1. The factory default for TMIN, TMAX, and POT0 values are 0, 250, and 0 in decimal, respectively. TMIN and TMAX on this screen are read only, but you can change them using the LCD Function File in your application program. The TMIN and TMAX elements can only be changed by a program download.

For more information on how to change Trim Pot configuration including TMIN and TMAX, refer to the LCD Function File described in the *MicroLogix 1400 Programmable Controllers Instruction Set Reference Manual*, publication [1766-RM001](#).

IMPORTANT The same TMIN and TMAX values are used for both trim pots, POT0 and POT1. This behavior is intended by design for simplicity in Trim Pot configuration.

When you enter this screen, the last digit of the POT0 value is flashing. It indicates the current digit. Press the Up and Down keys on the LCD keypad to change the value of the current digit. Press the Left and Right keys to select a different digit as the current digit.

If the Key In mode is set to Continuous, the changes are applied immediately after you press the Up and Down keys. While, if it is set to Discrete, you have to press the OK key to apply the changes after you change the data value. For more information on how to set the Key In mode, see Changing Key In Mode on page 134.

TIP The Key In mode has an effect only when you change the data value of a trim pot on a Trim Pot screen, either the Trim Pot 0 or Trim Pot 1 screen.

5. If you have finished changing the data value of the selected trim pot, POT0 in this example, press the ESC key to return to the Trim Pot Select screen, as shown in step 2.

Trim Pot Configuration in LCD Function File

The configuration for Trim Pots in the LCD Function File, including trim pot low and high values for data value range, is described in the *MicroLogix 1400 Programmable Controllers Instruction Set Reference Manual*, publication [1766-RM001](#).

Error Conditions

Error conditions regarding the Trim Pot functionality are described in the *MicroLogix 1400 Programmable Controllers Instruction Set Reference Manual*, publication [1766-RM001](#).

Viewing System Information

The System Information screen of the LCD allows you to identify the system information for your controller.

Follow these steps to view the system information for your controller.

1. On the Main Menu screen, select Advanced Set by using the Up and Down keys on the LCD keypad, as shown below. If the menu items shown in the figure below are not displayed on the Main Menu screen, you need to scroll down the screen by pressing the Down key.



Note: The Security menu is available in firmware revision FRN 21 and higher.

2. Then, press the OK key on the LCD keypad. The Advanced Set Menu screen is displayed, as shown below.

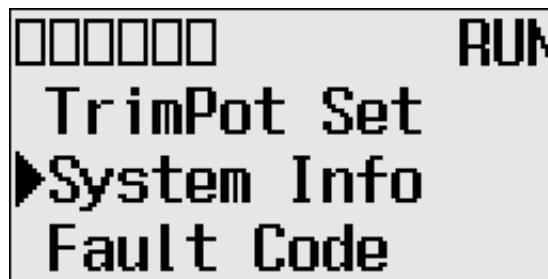

3. If System Info is selected, press the OK key.
If not, select System Info using the Up and Down keys, and then press the OK key.
4. The System Information screen is displayed.

You can identify the catalog number, operating system firmware revision number, and boot firmware revision number of your controller.

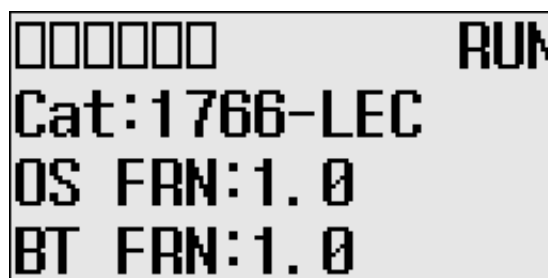

5. Press the ESC key to return to the Advanced Set Menu screen, as shown in step 3.

Viewing Fault Code

The Fault Code screen of the LCD displays the fault code when a fault occurs.

When a fault occurs, the Fault Code screen is not displayed automatically. Only the FAULT LED on the controller flashes in red light. Therefore, you need to navigate into the Fault Code screen to identify the fault code on the LCD.

Follow these steps to view the fault code when a fault occurs.

1. On the Main Menu screen, select Advanced Set by using the Up and Down keys on the LCD keypad, as shown below. If the menu items shown in the figure below are not displayed on the Main Menu screen, you need to scroll down the screen by pressing the Down key.



Note: The Security menu is available in firmware revision FRN 21 and higher.

2. Then, press the OK key on the LCD keypad. The Advanced Set Menu screen is displayed, as shown below.

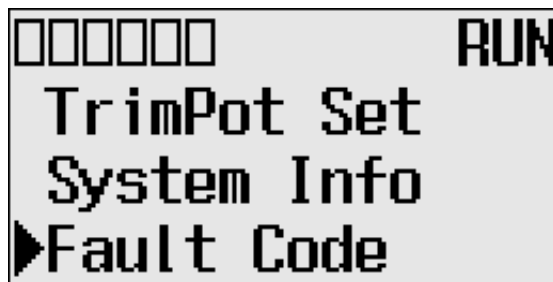

3. If Fault Code is selected, press the OK key. If not, select Fault Code using the Up and Down keys, and then press the OK key.
4. The Fault Code screen is displayed.

If no fault occurred, “0000h” is displayed, as shown below.

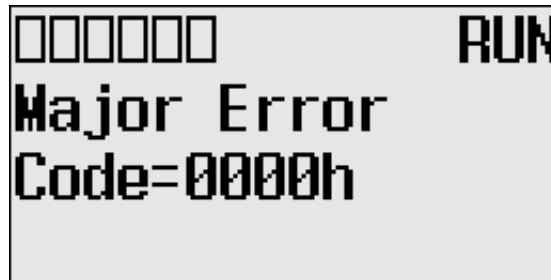

If a fault is occurred, its fault code is displayed, as shown below.



TIP For more information on a specific fault code, refer to the *Online Help* of your RSLogix 500/RSLogix Micro programming software.

5. Press the ESC key to return to the Advanced Set Menu screen, as shown in step 2.

Saving/Loading Communication EEPROM

At the communication EEPROM screen, you can load/save user programs and data to/from the Memory module.

Saving Communication EEPROM

Follow these steps to save user program and data from controller's memory to memory module.

1. On the Main Menu screen, select Advanced Set by using the Up and Down keys on the LCD keypad.
If the menu items shown are not displayed on the Main Menu screen, scroll down by pressing the Down key.



Note: The Security menu is available in firmware revision FRN 21 and higher.

2. Press the OK key on the LCD keypad.
3. Select Comms EEPROM using the Down key, and then press the OK key.



4. Select Store to MM to save user program and data, and then press the OK key.

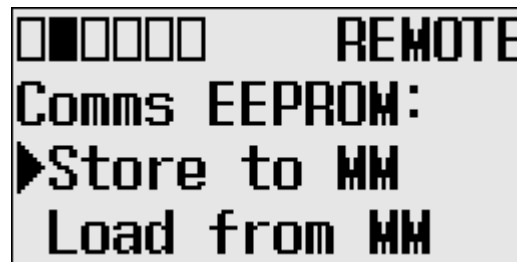

5. If your controller is in a non-executing mode, skip to the next step. Otherwise switch your controller to a non-executing mode.

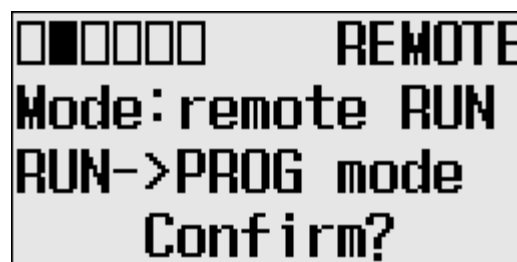

6. The usual method for using a memory module is to reuse the device. Select Reuse Device or Write Only by pressing the Up or Down keys.

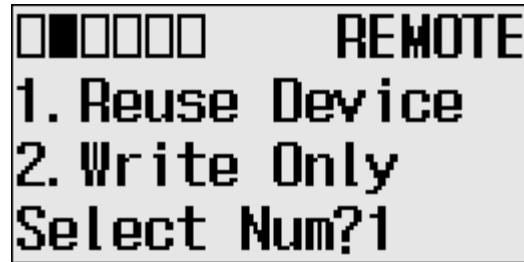

□■□□□□ REMOTE
1. Reuse Device
2. Write Only
Select Num?1

IMPORTANT

Once set to Write Only mode, write protection cannot be removed. If a change is required, use a different memory module. For more information on this, refer to the chapter of Memory Module operation.

Once Write Only is set, write protection cannot be removed. A change cannot be made to the control program stored in a write protected memory module. If a change is required, use a different memory module.

For more information on transferring data to and from memory modules, see [Memory Module Operation on page 172](#).

7. This screen appears if the save is complete. Press the OK key to go back to executing mode.

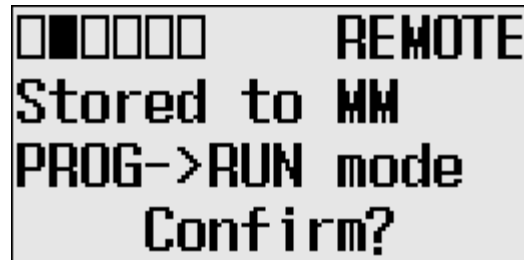

□■□□□□ REMOTE
Stored to MM
PROG->RUN mode
Confirm?

Loading communication EEPROM

Follow these steps to load user programs and data from the memory module to the controller's memory.

1. Select Load from MM to load user programs and data.

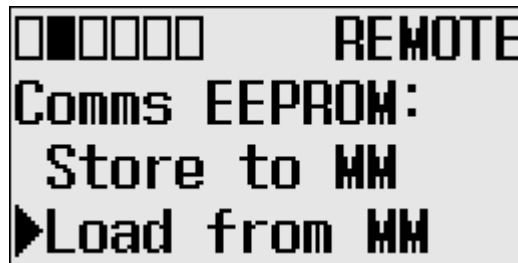

2. If your controller is in a non-executing mode, skip to the next step. Otherwise switch your controller to a non-executing mode.

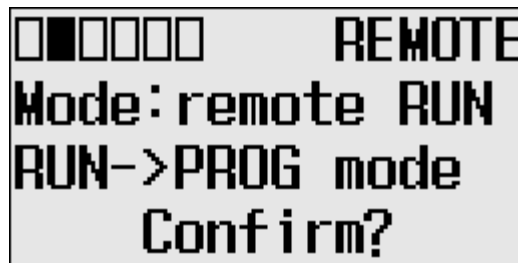

3. This screen appears if the load from the memory module is complete. Press the OK key to go back to executing mode.

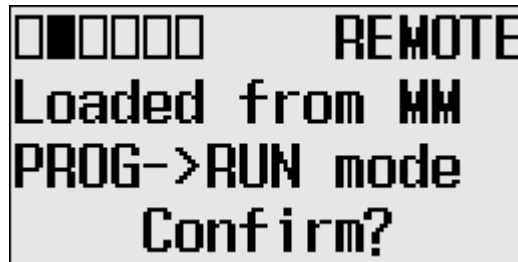

TIP For more information on transferring data to and from memory modules, see Memory Module Operation on page 159.

LCD setup

In the LCD Setup screen, you can configure the contrast value and backlight for the LCD.

Configuring contrast value

1. On the Main Menu screen, select Advanced Set by using the Up and Down keys on the LCD keypad.
If the menu items shown are not displayed on the Main Menu screen, scroll down by pressing the Down key.



Note: The Security menu is available in firmware revision FRN 21 and higher.

2. Press the OK key on the LCD keypad.
3. Select LCD Setup, using the Up and Down keys on the LCD keypad.
When the LCD Setup menu screen is displayed, press the OK key.



4. Select Contrast to adjust the contrast of LCD.



5. Adjust the contrast value using the Left and Right keys on the LCD keypad.

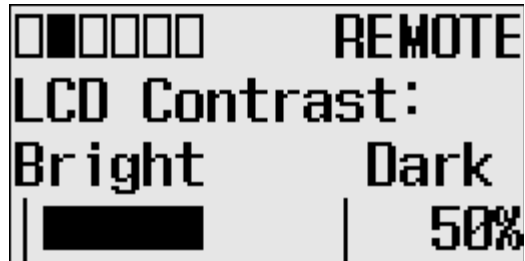

Configuring the backlight

1. On the Main Menu screen, select Advanced Set by using the Up and Down keys on the LCD keypad.
If the menu items shown are not displayed on the Main Menu screen, scroll down by pressing the Down key.



Note: The Security menu is available in firmware revision FRN 21 and higher.

2. Press the OK key on the LCD keypad.
3. Select LCD Setup, using the Up and Down keys on the LCD keypad.
When the LCD Setup menu screen is displayed, press the OK key.

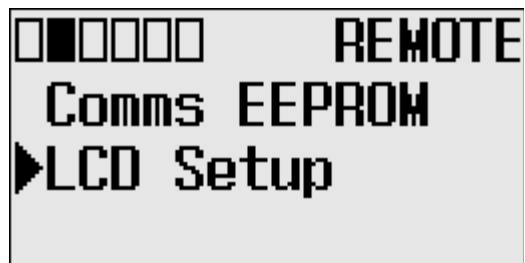

4. Select Back Light to adjust backlighting options for the LCD.

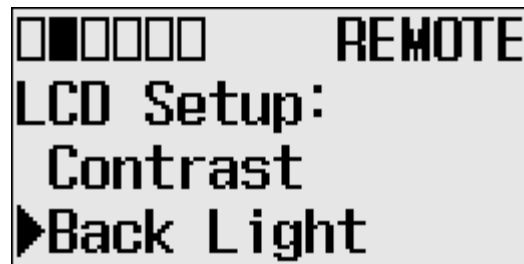

5. The default value for the backlight is 30 seconds. You can adjust backlight time using the Up and Down keys on the LCD keypad.

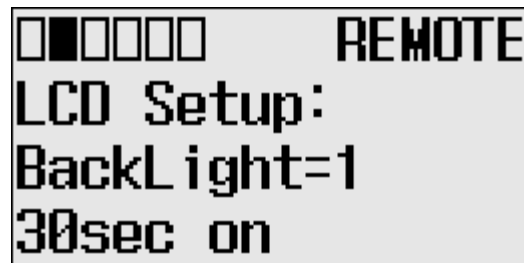

Protocol Configuration

The following section provides a step-by-step guide on how to change the Modbus Node address.

Modbus RTU Slave Node Address

The user can set the Modbus RTU Slave Node address for Channel 0 or 2.

TIP The node address change will only be applicable after a power cycle.

Changing the Modbus RTU Slave Node address

1. On the Main Menu screen, select Advanced Set by using the Up or Down arrow key on the LCD keypad. If the menu items shown in the figure are not displayed on the Main Menu screen below, you need to scroll down the screen by pressing the Down arrow key.



Note: The Security menu is available in firmware revision FRN 21 and higher.

2. Then, press the OK key on the LCD keypad. The Advanced Settings Menu screen is displayed.

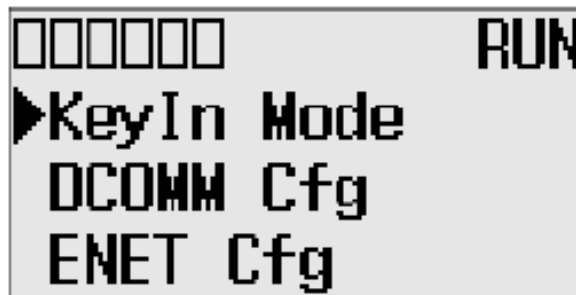

3. Select the Protocol Cfg using the Up and Down arrow keys, and then press the OK key.

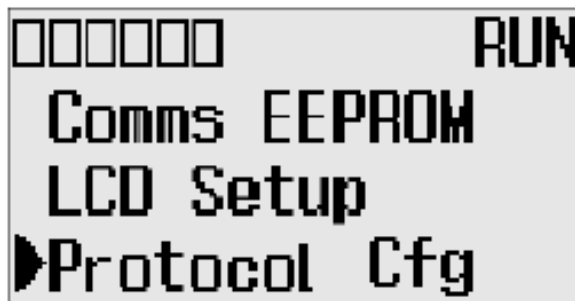

4. Select the Modbus RTU Sl and then press the OK key.



5. The Modbus RTU Slave screen is displayed. Channel 0 is selected below.

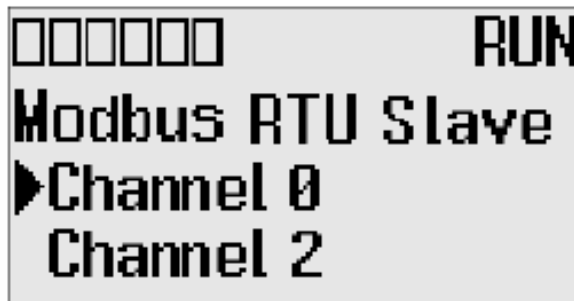

6. Press the Up or Down arrow key to select a different channel, Channel 2 in this example. Press the OK key.

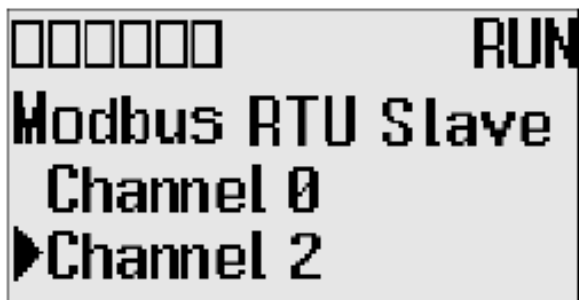

7. If the channel selected is not configured with the Modbus RTU Slave driver, then Modbus Not Configured is displayed, as shown below.



- 8. If channel 0 is configured with the Modbus RTU Slave driver with node address 100, the following screen will appear as shown.



- 9. If channel 2 is configured with the Modbus RTU Slave driver with node address 100, the following screen will appear as shown.



- 10. The user can configure the node address for either channel by using the Up and Down arrow keys. Once the address is changed, press OK to confirm the change. The following screen appears.

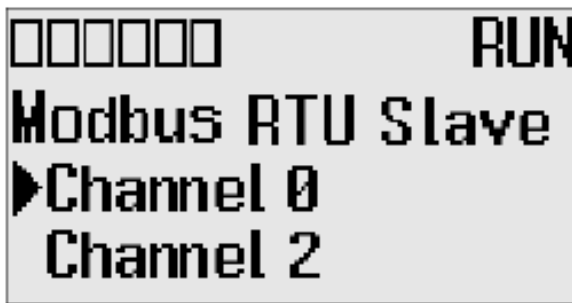

LCD Password Setup

The following section provides a step-by-step guide on how to set, change, activate and deactivate the LCD Password in firmware revision FRN 21 and higher.

Set the LCD Password

1. On the Main Menu, select Security by using the Up and Down keys on the LCD keypad. If the menu items shown are not displayed on the Main Menu screen, scroll down by pressing the Down key.



2. Select Security to set the LCD Password. If LCD Password is not set, Activate PWD menu screen is displayed.



3. Select Activate PWD menu to set the LCD Password. LCD Password screen is displayed. Digit at current cursor position blinks always.



4. Press the Up or Down keys to change the digit and the Left or Right keys to move the cursor position. Enter the LCD Password up to a maximum of 10 digits. In this example, the current LCD Password is allocated as "1234".



5. Press OK on the LCD keypad to set the entered password. A confirmation screen displays.



6. Press OK to set and activate the LCD Password. When the Password is activated a key symbol appears at the top of the display.



Activate the LCD Password

1. On the Main Menu, select Security by using the Up and Down keys on the LCD keypad. If the menu items shown are not displayed on the Main Menu screen, scroll down by pressing the Down key.



2. Select Security. If the LCD Password is set, the LCD Password configuration menu screen displays.



3. Select Activate PWD to activate the LCD Password which is already stored in controller but deactivated. A confirmation screen displays.



4. Press the OK key. The existing LCD Password is activated. When the Password is activated a key symbol appears at the top of the display.



Deactivate the LCD Password

1. On the Main Menu, select Security by using the Up and Down keys on the LCD keypad.



2. Select Security to deactivate the LCD Password. If an LCD Password is set, the LCD Password configuration menu screen displays.



3. Select Deactivate PWD to deactivate the LCD Password. An authentication screen displays.



4. Enter the LCD Password and press the OK key to deactivate the LCD Password.
A notification screen displays and the key symbol no longer appears at the top of the display.



5. Press the OK key.
The LCD Password remains stored in the controller but is deactivated.

Change LCD Password

1. On the Main Menu, select Security by using the Up and Down keys on the LCD keypad.



2. Select Security to change the LCD Password. If an LCD Password is set, the LCD Password configuration menu screen displays.



3. Select Change PWD to change the LCD Password. The LCD password change screen displays.



4. Press the Up or Down keys to change the digit and press the Left or Right keys to move the cursor position. Enter the old (current) and new LCD Passwords.

In this example, the old and new LCD Passwords are "1234" and "5670000009".

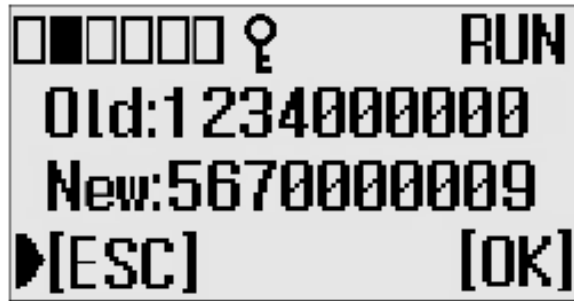

NOTE: If you want to clear the LCD Password, instead of deactivating it, enter the new password as "0000000000". A confirmation screen displays.

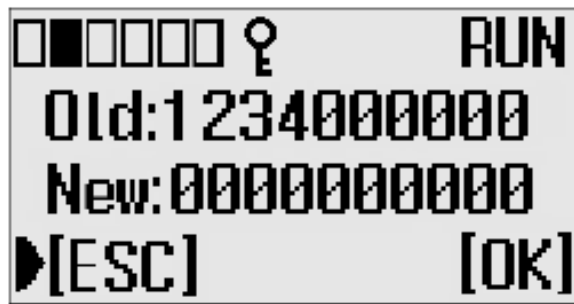

Press the OK key to clear the LCD Password. A confirmation screen displays.



5. Press the OK key on the LCD keypad to change the password. A confirmation screen displays.

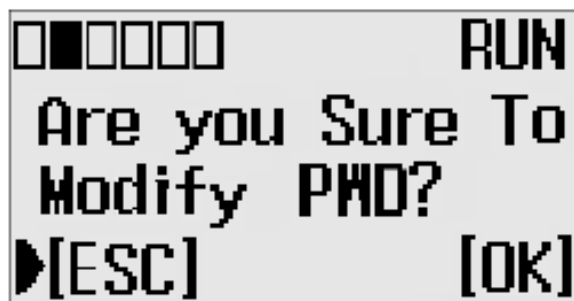

Notes:

Using Real-Time Clock and Memory Modules

The MicroLogix 1400 controller has a built-in real-time clock (RTC). You can order a memory module as an accessory.

TIP For more information on “Real-Time Clock Function File” and “Memory Module Information File”, refer to the MicroLogix 1400 Programmable Controllers Instruction Set Reference Manual, publication [1766-RM001](#).

One type of memory module is available for use with the MicroLogix 1400 controller.

Catalog Number	Function	Memory Size
1766-MM1	Memory Module	384 KB

Real-Time Clock Operation Operation at Power-up and Entering a Run or Test Mode

At power-up and when the controller enters a run or test mode, the values (date, time and status) of the RTC are written to the RTC Function File in the controller.

The following table indicates the accuracy of the RTC for various temperatures.

RTC Accuracy

Ambient Temperature	Accuracy ⁽¹⁾
0 °C (32 °F)	-13...-121 seconds/month
25 °C (77 °F)	54...-5 seconds/month
40 °C (104 °F)	29...-78 seconds/month
55 °C (131 °F)	-43...-150 seconds/month

⁽¹⁾ These numbers are maximum worst case values over a 31-day month.

Writing Data to the Real-Time Clock

When valid data is sent to the real-time clock from the programming device or another controller, the new values take effect immediately.

The real-time clock does not allow you to load or store invalid date or time data.

RTC Battery Operation

The real-time clock uses the same replaceable battery that the controller uses. The RTC Function File features a battery low indicator bit (RTC:0/BL), which shows the status of the replacement battery. When the battery is low, the indicator bit is set (1). This means that the battery wire connector could be disconnected or if the battery is connected, the battery may be ready to fail in the next two weeks. In the latter case, the replacement battery needs to be replaced with a new one. When the battery low indicator bit is clear (0), the battery level is acceptable.

The Battery Low (BAT.LO) indicator on the LCD display of the controller also shows the status of the replaceable battery. When the battery is low, the indicator is displayed as a solid rectangle (■). When the battery level is acceptable, the indicator is displayed as an empty rectangle (□), as shown below.

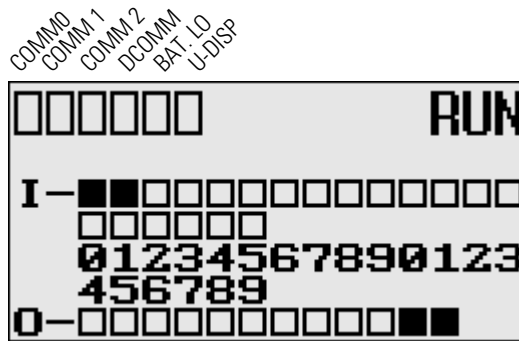

If the RTC battery is low and the controller is powered, the RTC operates normally. If the controller power is removed and the RTC battery is low, RTC data is lost.



ATTENTION: Operating with a low battery indication for more than 2 weeks may result in invalid RTC data unless power is on continuously.

Memory Module Operation

The memory module supports the following features:

- User Program, User Data, Datalog, and Recipe Back-up
- User Program Compare
- Data File Download Protection
- Memory Module Write Protection
- Removal/Insertion Under Power



ATTENTION: Electrostatic discharge can damage the Memory Module. Do not touch the connector pins or other sensitive areas.

User Program, User Data, Datalog, and Recipe Back-up

The memory module provides a simple and flexible program, data, DataLog, and Recipe transport mechanism, allowing the user to transfer the program, data, DataLog, and Recipe to the controller without the use of a personal computer and programming software.

The memory module can store one user program at a time.

During program transfers to or from the memory module, the controller's RUN LED flashes.

Program Compare

The memory module can also provide application security, allowing you to specify that if the program stored in the memory module does not match the program in the controller, the controller will not enter an executing (run or test) mode. To enable this feature, set the S:2/9 bit in the system status file. See "Status System File" in the *MicroLogix 1400 Programmable Controllers Instruction Set Reference Manual*, Publication [1766-RM001](#) for more information.

Data File Download Protection

The memory module supports data file download protection. This allows user data to be saved (not overwritten) during a download.

TIP Data file download protection is only functional if the processor does not have a fault, size of all protected data files in the memory module exactly match the size of protected data files within the controller, and all protected data files are of the same type. See "Protecting Data Files During Download" in the *MicroLogix 1400 Programmable Controllers Instruction Set Reference Manual*, Publication [1766-RM001](#).

Memory Module Write Protection

The memory module supports write-once, read-many behavior. Write protection is enabled using your programming software.

IMPORTANT Once set, write protection cannot be removed. A change cannot be made to the control program stored in a write protected memory module. If a change is required, use a different memory module.

Removal/Insertion Under Power

The memory module can be installed or removed without risk of damage to either the memory module or the controller, except during a data transaction. If the memory module is removed during a data transaction, data corruption can occur.

If a memory module is installed while the MicroLogix 1400 is executing, the memory module is not recognized until either a power cycle occurs, or until the controller is placed in a non-executing mode (program mode, suspend mode or fault condition).

Memory Module Information File

The controller has a Memory Module Information (MMI) File which provides status from the attached memory module. At power-up or on detection of a memory module being inserted, the catalog number, series, revision, and type are identified and written to the MMI file. If a memory module is not attached, zeros are written to the MMI file. Refer to the *MicroLogix 1400 Instruction Set Reference Manual*, publication [1766-RM001](#), for more information.

Program /Data Download

To download the program and data from a memory module to the controller's memory, on the "Comms" menu in your RSLogix 500/RSLogix Micro programming software, point "EEPROM" and then click "Load from EEPROM".

TIP With MicroLogix 1400, you can also use the LCD and the LCD buttons on the module to transfer applications to or from the controller.
For more information on program/data download, refer to your RSLogix 500/RSLogix Micro programming software documentation.

Program /Data Upload

To upload the program and data from the controller's memory to a memory module, on the "Comms" menu in your RSLogix 500/RSLogix Micro programming software, point "EEPROM" and then click "Store to EEPROM".

TIP With MicroLogix 1400, you can also use the LCD and the LCD buttons on the module to transfer applications to or from the controller.
For more information on program/data upload, refer to your RSLogix 500/RSLogix Micro programming software documentation.

Online Editing

Overview of Online Editing

Online editing of ladder programs is available when using MicroLogix 1400 processors. Use this function to make changes to a pre-existing ladder program. Online editing functions consist of inserting, replacing, and deleting rungs in an existing ladder program while online with the processor.

Only one programming device can perform an online edit of a user program at a time. When an online editing session begins, an access from other programming devices will be rejected by MicroLogix 1400.



WARNING: Before initiating an online editing session, we recommend that you fully understand the possible results of the edit to the system under control. Failure to properly edit a running program could result in unexpected controller operation. Physical injury or equipment damage may result.

While three instructions, MSG, PTO, and PWM, are supported by program mode online edit, they are not supported by RUNTIME (RUN mode) online edit. Refer to the MicroLogix™ 1400 Instruction Set Reference Manual, publication 1766-RM001 for additional details.

The following table summarizes the differences between offline and online editing.

Offline	Online
No restrictions exist. Full editing capabilities are allowed.	Data table file resizing is not permitted.
	Program file creation and deletion are not permitted.
	Alteration of file protection is not permitted.
	Alteration of static and constant data file values is not permitted.
	Indexing across file boundary selections is not permitted.
	Force protection selection is not permitted.
	I/O configuration is not permitted.

IMPORTANT It is important to keep in mind that some ladder instructions, when programmed online, cause data table values to change. These instructions are those that require timer, counter, and control addresses to be specified. This is discussed later in the chapter.

Online Editing Terms

The following terms are used throughout this chapter.

- **Assemble Edits** — Deletes any rungs marked with Delete or Replace edit zone markers during an online editing session. Inserted or modified rungs remain. All edit zone markers are removed when this function is complete.
- **Cancel Edits** — Deletes any inserted or modified rungs added during an online editing session. Rungs marked with Delete and Replace edit zone markers remain. All edit zone markers are removed when this function is complete.
- **Test Edits** — Allows you to verify that the changes you entered are not going to cause improper machine operation before you make the changes a permanent part of your ladder program.
- **Untest Edits** — Allows you to disable testing.
- **Edit Zone markers** — Appear on the power rail of the ladder program display. They indicate the type of edit taking place on the rung.
- **Accept Rung** — Incorporates the edits of a single rung into the ladder program.
- **online edit session** — begins when a user tries to edit rungs while online. Any other programming device that was monitoring the user program is removed from the program monitor display.
- **modify rung** — when an existing rung is modified two edit zones are created. The original rung is indicated by replace zone markers on the power rail. A copy of the original rung is made so you can insert, delete, or modify instructions. This rung is indicated by insert zone markers on the power rail. Thus, an IR pair is created when you modify a rung.
- **runtime online editing** — the user program is executing when an edit takes place. Any rungs that are inserted, modified, or deleted remain in the ladder program and are indicated by edit zone markers on the power rail. Edit zone markers remain after an action is completed.
- **program online editing** — the user program is not executing when an edit session begins. Any action that inserts, deletes, or modifies a rung takes place immediately.

The following figure shows the process involved when performing a runtime online edit.

Effects of Online Editing On Your System

The following section covers the effects of online editing on your system. Keep these items in mind while using the online editing function.

System Impacts

The scan time and interrupt latency can be extended when accepting a rung, assembling, or canceling edits.

Memory limitations - Online edit can be performed until there is insufficient program memory available in the processor. Note that, before assemble edits, all the edited rungs are in the processor memory consuming memory, although they are not executed.

Data Table File Size

Online editing cannot change the size of existing data tables nor can new ones be created. However, some ladder instructions, when programmed cause data table values to change. These instructions are those that require timer, counter, and control addresses to be specified.

Online Edit Error

If either electrical interference, communication loss, or a power cycle occur during online edit session, program integrity may be impacted. In this case, the controller will generate the 1F fault code, clear the user program, and load the default program.

Directions and Cautions for MicroLogix 1400 Online Editing User

A Download is Required Before Starting Online Editing

At least one download is required before you can start online editing.

If you are using a MicroLogix 1400 from out-of-box state or after clearing processor memory or a firmware upgrade, at least one download is required before starting online edits. If not, an error occurs and programming software will go offline due to a default image mismatch between programming software (RSLogix 500®) and the MicroLogix 1400. You can also see the fault code 1Fh which is a user defined fault code.

In order to prevent this error, you need to download the program to the MicroLogix 1400, although the program is empty.

This problem happens only in out-of-box state or after clear processor memory.

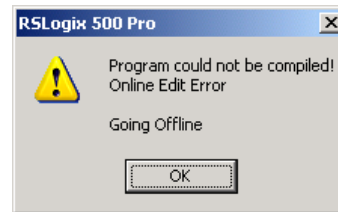

ATTENTION: PTO and PWM instructions may not be deleted during runtime online edit. This is because if the PTO or PWM instructions were deleted during runtime online edit, outputs could stop in an unpredictable state, causing unexpected equipment operation.

If you attempt to insert or modify a rung with MSG, PTO, and PWM instruction, the following error message will be generated by programming software "Error: Online editing of PTO, PWM, and MSG are not allowed on ML1400 RUN mode." And, the rung with MSG, PTO, and PWM instruction will not be accepted.

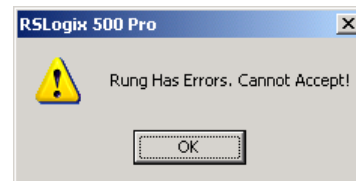

In online edit during PROGRAM mode (program online edit), there are no restrictions. For example, a user can insert MSG instruction if related MG file or MG/RI file is already defined in data file.



ATTENTION: When editing a rung that contains an MCR instruction, both the MCR start and MCR end rungs must be edited (whether it be test/assemble/cancel) at the same time. We recommend that you fully understand the possible results of the edit to the system under control. Failure to properly edit a running program could result in unexpected controller operation. Physical injury or equipment damage may result.



ATTENTION: If you use EII or STI interrupts and your application requires a quick interrupt latency, the online edit feature is not recommended. Online editing feature may increase the interrupt latency response time. To ensure minimum interrupt latency, place the mode switch in LCD screen in the RUN mode. This prevents the use of the online editing feature.

Types of Online Editing

The type of online editing is dependent on the MicroLogix 1400 processor's mode switch position in LCD display and the processor's mode. There are two types of online editing:

- Program Online Editing — when the processor is in either PROG mode or REM Program mode
- Runtime Online Editing — when the processor is in either REM Test or REM Run mode

The following table summarizes the MicroLogix 1400 processor mode switch positions in LCD and modes that enable online editing.

mode switch Position	MicroLogix 1400 Processor Mode	Editing Mode
RUN	RUN	Not Available
PROGram	Program	Program Online Editing
REMote	REMote Program	Program Online Editing
REMote	REMote Test	Runtime Online Editing
REMote	REMote Run	Runtime Online Editing

IMPORTANT

Online editing is not available when the mode switch in LCD screen is in the RUN position.



ATTENTION: Use the online editing function while in the RUN mode to make minor changes to the ladder program. We recommend developing your program offline since ladder rung logic changes take effect immediately after testing your edits. Improper machine operation may occur, causing personnel injury or equipment damage.

Edit Functions in Runtime Online Editing

During a runtime online editing session, the processor *is executing* ladder logic. The edit zone markers tell the processor that changes exist, but the changes are not executed until you test the edits.

Deleted and replaced (modified) rungs are not removed from the program and inserted rungs are not executed until you assemble or test the edits.

Edit Functions in Program Online Editing

During a program online editing session, the processor *is not executing* ladder logic. This mode is like the offline editing mode. Note that if a runtime online editing session was performed prior to entering the offline editing mode, edit marked rungs (I, R, and D) *appear* in the program.

If you perform a program online edit, once you accept or delete the rung, the edits take effect immediately and the power rail is displayed as a solid line. If you edit a rung with edit zone markers, the markers are removed when the rung is accepted.

Specifications

General Specifications

Description	1766-L32AWA/A	1766-L32BWA/A	1766-L32BXB/A
Dimensions HxWxD	90 x 180 x 87 mm 3.5 x 7.08 x 3.43 in.		
Shipping weight	0.9 kg (2.0 lbs)		
Number of I/O	24 inputs (20 digital and 4 analog) and 14 outputs (12 digital and 2 analog)		
Power supply voltage	100...240V AC at 47...63 Hz		24V DC Class 2 SELV
Heat dissipation	See System Loading and Heat Dissipation on page 399 .		
Power supply inrush current	120V AC: 25 A for 8 ms 240V AC: 40 A for 4 ms		24V DC: 15 A for 20 ms
Power consumption	100 VA 130 VA (Series C)	120 VA 150 VA (Series C)	50W 7.5W (with no 1762 expansion I/O)
24V DC sensor power	none	24V DC at 250 mA 400 µF max.	none
Input circuit type	Digital: 120V AC Analog: 0...10V DC	Digital: 24V DC sink/source (standard and high-speed) Analog: 0...10V DC	Digital: 24V DC sink/source (standard and high-speed) Analog: 0...10V DC
Output circuit type	Relay		Relay/FET
Relay life - Electrical	See Relay Life Chart		
Relay life - Mechanical	20,000,000 cycles		
Enclosure type rating	None (open-style)		
Terminal screw torque	0.791 Nm (7.0 lb-in) rated		

Specifications for Inputs

Description	1766-L32AWA/A	1766-L32BWA/A, 1766-L32BXB/A	
		Inputs 0...11 (12 high-speed DC inputs)	Inputs 12 and higher (8 standard DC inputs)
On-state voltage range	79...132 V AC	4.5...24V DC (4.5...26.4V DC (+10%) at 60 °C/140 °F (4.5...30V DC (+25%) at 30 °C/86 °F)	10...24V DC (10...26.4V DC(+10%) at 60 °C/140 °F (10...30V DC (+25%) at 30 °C/86 °F)
Off-state voltage range	0...20 V AC	0...1.5V DC	0...5V DC
Operating frequency	47...63 Hz	0 Hz...100 kHz	0 Hz...1 kHz (scan time dependent)
On-state current			
Minimum	9.0 mA @ 79 V AC	7.0 mA @ 4.5V DC	3.0 mA @ 10V DC
Nominal	12 mA @ 120 V AC	9.5 mA @ 24V DC	5.0 mA @ 24V DC
Maximum	16.0 mA @ 132 V AC	10.0 mA @ 30V DC	5.5 mA @ 30V DC

Description	1766-L32AWA/A	1766-L32BWA/A, 1766-L32BXB/A	
		Inputs 0...11 (12 high-speed DC inputs)	Inputs 12 and higher (8 standard DC inputs)
Off-State Leakage Current	2.5 mA max.	0.1 mA max	1.5 mA max.
Nominal Impedance	12 k Ω at 50 Hz 10 k Ω at 60 Hz	2.0 k Ω	5.5 k Ω
Inrush Current (max.) at 120V AC	30 A		

Analog Inputs

Description	1766-L32AWA/A, -L32BWA/A, -L32BXB/A
Voltage input range	0...10.0V DC - 1 LSB
Type of data	12-bit unsigned integer
Input coding (0...10.0V DC - 1 LSB)	0...4095
Voltage input impedance	>199 k Ω
Input resolution	12 bit
Non-linearity	\pm 0.5% of full scale
Overall accuracy -20...+65 °C (-4...+149 °F)	\pm 1.0% of full scale
Update tim	100/20/16.67/4 ms (selectable)
Voltage input overvoltage protection	10.5 V DC
Field wiring to logic isolation	Non-isolated with internal logic

Analog Outputs

Description	1766-L32AWA/A, -L32BWA/A, -L32BXB/A
Number of inputs	2 single-ended
Voltage output range	0...10 V DC - 1 LSB
Type of data	12 bit unsigned integer
Step response	2.5 ms @ 95%
Load range Voltage output	>1 K Ω
Output coding (0...10V DC)	0...4095
Output resolution	12 bit
Analog output setting time	3 ms (max.)
Overall Accuracy -20...60 °C (-4...140 °F)	\pm 1.0% of full scale
Electrical isolation	Non-isolated with internal logic
Cable length	30 m (98 ft) shielded cable

Relay and FET Outputs

Description		1766-L32AWA/A, 1766-L32BWA/A	1766-L32BXB/A
Maximum controlled load		1440 VA	1080 VA
Maximum Continuous Current:			
Current per channel and group common		2.5 A per channel 8A max channel 8...11 common	2.5 A per channel
Current per controller	at 150V max	28 A or total of per-point loads, whichever is less	
	at 240V max	20 A or total of per-point loads, whichever is less	

Relay Outputs

Description	1766-L32AWA/A, 1766-L32BWA/A, 1766-L32BXB/A
Turn On Time/Turn Off Time	10 ms (maximum) ⁽¹⁾
Load current	10 mA (minimum)

(1) Scan time dependent

Relay Contact Ratings⁽¹⁾

Maximum Volts	Amperes		Amperes Continuous	Volt-Amperes	
	Make	Break		Make	Break
240V AC	7.5 A	0.75 A	2.5 A	1800 VA	180 VA
120V AC	15.0 A	1.5 A	2.5 A	1800 VA	180 VA
250V DC	0.11 A		1.0 A	28 VA	
125V DC	0.22 A		1.0 A	28 VA	

(1) Pilot Duty Rating (at Relay Contact Ratings): C300, R300.



ATTENTION: Do not exceed the "Current per group common" specification.

Relay Life Chart

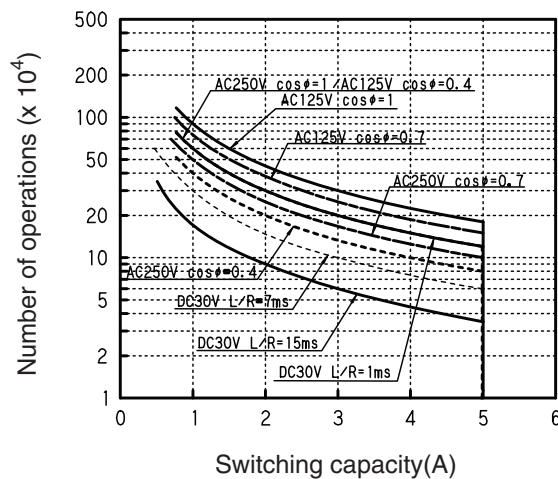
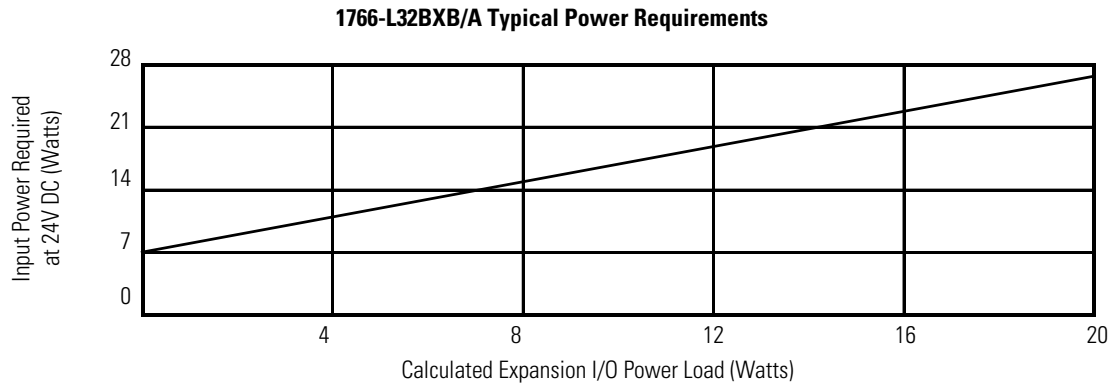
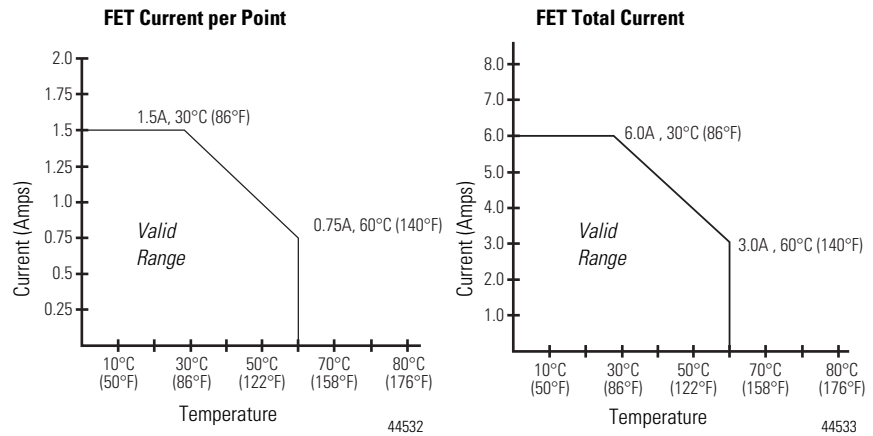

Figure 1 - MicroLogix 1400 DC Input Power Requirements for 1766-L32BXB/A Unit



**Figure 2 - 1766-L32BXB, 1766-L32BXB/A FET Output
Maximum output current (temperature dependent):**



Description	General Operation	High Speed Operation ⁽¹⁾ (Output 2, 3 and 4 Only)
Power supply voltage	24V DC (-15%, 10%) Class 2	
On-state voltage drop: at max load current at max surge current	1V DC 2.5V DC	Not Applicable Not Applicable
Current rating per point: max load min load max leakage	See graphs above 50 mA 1.0 mA	100 mA 50 mA 1.0 mA
Surge current per point: peak current max surge duration max rate of repetition at 30 °C (86 °F) max rate of repetition at 60 °C (140 °F)	4.0 A 10 ms once every second once every 2 seconds	Not Applicable Not Applicable Not Applicable Not Applicable
Turn-On Time (maximum)	11 μs	28 ns
Turn-Off Time (maximum)	89 μs	3.5 μs

(1) Output 2, 3 and 4 are designed to provide increased functionality over the other FET outputs. Output 2, 3 and 4 may be used like the other FET transistor outputs, but in addition, within a limited current range, they may be operated at a higher speed. Output 2, 3 and 4 also provide a pulse train output (PTO) or pulse width modulation output (PWM) function.

AC Input Filter Settings

Nominal Filter Setting (ms)	ON Delay (ms)		OFF Delay (ms)	
	Minimum	Maximum	Minimum	Maximum
8	2.3	2.5	11	12

High-Speed DC Input Filter Settings (Inputs 0 to 11)

Nominal Filter Setting (ms)	ON Delay (ms)		OFF Delay (ms)		Maximum Counter Frequency (Hz) 50% Duty Cycle
	Minimum	Maximum	Minimum	Maximum	
0.005	0.001	0.005	0.001	0.005	100.0 kHz
0.008	0.003	0.008	0.003	0.008	60.0 kHz
0.0125	0.0075	0.0125	0.007	0.0115	40.0 kHz
0.025	0.019	0.025	0.018	0.023	20.0 kHz
0.075	0.062	0.072	0.066	0.074	6.7 kHz
0.100	0.089	0.100	0.088	0.098	5.0 kHz
0.250	0.229	0.250	0.228	0.248	2.0 kHz
0.500	0.459	0.500	0.455	0.492	1.0 kHz
1.00	0.918	0.995	0.910	0.979	0.5 kHz
2.000	1.836	1.986	1.820	1.954	250 Hz
4.000	3.672	3.968	3.640	3.904	125 Hz
8.000 ⁽¹⁾	7.312	7.868	7.280	7.804	63 Hz
16.000	14.592	15.668	14.560	15.604	31 Hz

(1) This is the default setting.

Standard DC Input Filter Settings (Inputs 4 and higher)

Nominal Filter Setting (ms)	ON Delay (ms)		OFF Delay (ms)		Maximum Frequency (Hz) 50% Duty Cycle
	Minimum	Maximum	Minimum	Maximum	
0.500	0.107	0.439	0.024	0.499	1.0 kHz
1.000	0.597	0.964	0.470	0.978	0.5 kHz
2.000	1.437	1.864	1.415	1.990	250 Hz
4.000	3.397	3.964	3.095	3.790	125 Hz
8.000 ⁽¹⁾	6.757	7.564	6.735	7.690	63 Hz
16.000	14.597	15.964	13.455	14.890	31 Hz

(1) This is the default setting.

Analog Input Filter Settings

Analog Input Filter Settings	Filter Bandwidth (-3dB Freq Hz)	Sampling Frequency
250 Hz	250 Hz	1 kHz
60 Hz	60 Hz	1 kHz
50 Hz	50 Hz	1 kHz
10 Hz	10 Hz	1 kHz

Working Voltage

Working Voltage for 1766-L32AWA/A

Description	Recommendation
Power Supply Input to Backplane Isolation	Verified by one of the following dielectric tests: 1836V AC for 1 second or 2596V DC for 1 second
	265V AC Working Voltage (IEC Class 2 reinforced insulation)
Input Group to Backplane Isolation	Verified by one of the following dielectric tests: 1517V AC for 1 second or 2145V DC for 1 second
	132V AC Working Voltage (IEC Class 2 reinforced insulation)
Input Group to Input Group Isolation	Verified by one of the following dielectric tests: 1517V AC for 1 second or 2145V DC for 1 second
	132V AC Working Voltage (basic insulation)
Output Group to Backplane Isolation	Verified by one of the following dielectric tests: 1836V AC for 1 second or 2596V DC for 1 second
	265V AC Working Voltage (IEC Class 2 reinforced insulation)
Output Group to Output Group Isolation	Verified by one of the following dielectric tests: 1836V AC for 1 second or 2596V DC for 1 second
	265V AC Working Voltage (basic insulation), 150V AC Working Voltage (IEC Class 2 reinforced insulation)

Working Voltage for 1766-L32BWA/A

Description	Recommendation
Power Supply Input to Backplane Isolation	Verified by one of the following dielectric tests: 1836V AC for 1 second or 2596V DC for 1 second
	265V AC Working Voltage (IEC Class 2 reinforced insulation)
Input Group to Backplane Isolation and Input Group to Input Group Isolation	Verified by one of the following dielectric tests: 1100V AC for 1 second or 1697V DC for 1 second
	75V DC Working Voltage (IEC Class 2 reinforced insulation)
Output Group to Backplane Isolation	Verified by one of the following dielectric tests: 1836V AC for 1 second or 2596V DC for 1 second
	265V AC Working Voltage (IEC Class 2 reinforced insulation).
Output Group to Output Group Isolation	Verified by one of the following dielectric tests: 1836V AC for 1 second or 2596V DC for 1 second
	265V AC Working Voltage (basic insulation) 150V Working Voltage (IEC Class 2 reinforced insulation)

Working Voltage for 1766-L16BXB/A

Description	Recommendation
Input Group to Backplane Isolation and Input Group to Input Group Isolation	Verified by one of the following dielectric tests: 1100V AC for 1 second or 1697V DC for 1 second
	75V DC Working Voltage (IEC Class 2 reinforced insulation)
FET Output Group to Backplane Isolation	Verified by one of the following dielectric tests: 1100V AC for 1 second or 1697V DC for 1 second
	75V DC Working Voltage (IEC Class 2 reinforced insulation)
Relay Output Group to Backplane Isolation	Verified by one of the following dielectric tests: 1836V AC for 1 second or 2596V DC for 1 second
	265V AC Working Voltage (IEC Class 2 reinforced insulation)
Relay Output Group to Relay Output Group and FET Output Group Isolation	Verified by one of the following dielectric tests: 1836V AC for 1 second or 2596V DC for 1 second
	265V AC Working Voltage (basic insulation), 150V Working Voltage (IEC Class 2 reinforced insulation)

Expansion I/O Specifications

Digital I/O Modules

General Specifications

Specification	Value
Dimensions	90 mm (height) x 87 mm (depth) x 40.4 mm (width) height including mounting tabs is 110 mm 3.54 in. (height) x 3.43 in. (depth) x 1.59 in. (width) height including mounting tabs is 4.33 in.
Temperature, storage	-40 °C...85 °C (-40...185 °F)
Temperature, operating	-20...65 °C (-4...149 °F) ⁽¹⁾
Temperature, surrounding air, max.	60 °C (140 °F)
Operating humidity	5...95% non-condensing
Operating altitude	2000 m (6561 ft)
Vibration	Operating: 10...500 Hz, 5 g, 0.030 in. max. peak-to-peak, 2 hours per axis Relay Operation: 1.5 g
Shock	Operating: 30G panel mounted, 3 pulses per axis Relay Operation: 7 g Non-Operating: 50 g panel mounted, 3 pulses per axis (40G DIN Rail mounted)

(1) For module-specific operating temperature range, refer to the Installation Instructions for the specific module.

Environmental Specifications

Attribute	Value
Emissions	IEC 61000-6-4
ESD immunity	IEC 61000-4-2: 6 kV contact discharges 8 kV air discharges
Radiated RF immunity	IEC 61000-4-3: 10V/m with 1 kHz sine-wave 80% AM from 80...1000 MHz 3V/m with 1 kHz sine-wave 80% AM from 1.4...2.0 GHz 1V/m with 1 kHz sine-wave 80% AM from 2.0...2.7 GHz
EFT/B immunity	IEC 61000-4-4: ±2 kV @ 5 kHz on signal ports
Surge transient immunity	IEC 61000-4-5: ±1kV line-line(DM) and ±2kV line-earth(CM) on signal ports
Conducted RF immunity	IEC 61000-4-6: 10V rms with 1 Hz sine-wave 80% AM from 150 kHz...80 MHz

Certifications

Certification (when product is marked) ⁽¹⁾	Value
UL	UL Listed for Class I, Division 2 Group A, B, C, D Hazardous Locations
c-UL	UL Listed for Class I, Division 2 Group A, B, C, D Hazardous Locations, certified for Canada.
CE	European Union 2014/30/EU EMC Directive, compliant with: <ul style="list-style-type: none"> EN 61000-6-2; Industrial Immunity EN 61000-6-4; Industrial Emissions EN 61131-2; Programmable Controllers (Clause 8, Zone A & B) European Union 2014/35/EU LVD, compliant with: <ul style="list-style-type: none"> EN 61131-2; Programmable Controllers (Clause 11)
RCM	Australian Radiocommunications Act, compliant with: AS/NZS CISPR 11; Industrial Emissions
EAC	Russian Customs Union TR CU 020/2011 EMC Technical Regulation
KC	Korean Registration of Broadcasting and Communications Equipment, compliant with: Article 58-2 of Radio Waves Act, Clause 3

(1) See the Product Certification link at <http://www.rockwellautomation.com/products/certification/> for Declaration of Conformity, Certificates, and other certification details.

Input Specifications

Specification	1762-IA8	1762-IQ8	1762-IQ16	1762-IQ32T	1762-IQ80W6
Shipping weight, approx. (with carton)	209 g (0.46 lbs.)	200 g (0.44 lbs.)	230 g (0.51 lbs.)	200g (0.44 lbs.)	280g (0.62 lbs.)
Voltage category	100/120V AC	24V DC (sink/source) ⁽¹⁾	24V DC (sink/source) ⁽¹⁾	24V DC (sink/source) ⁽¹⁾	24V DC (sink/source) ⁽¹⁾
Operating voltage range	79V AC...132V AC at 47 Hz...63 Hz	10...30V DC at 30 °C (86 °F) 10...26.4V DC at 55 °C (131 °F)	10...30V DC 10...26.4V DC ⁽³⁾⁽²⁾	10...30V DC (24 points) at 30 °C (86 °F) 10...26.4V DC (23 points) at 60 °C (140 °F)	10...30V DC at 30 °C (86 °F) 10...26.4V DC at 65 °C (149 °F)
Number of inputs	8	8	16	32	8
Bus current draw, max.	50 mA at 5V DC (0.25W)	50 mA at 5V DC (0.25W)	70 mA at 5V DC (0.35W) ⁽³⁾	170 mA at 5V DC 0 mA at 24V DC	110 mA at 5V DC 80 mA at 24V DC
Heat dissipation, max.	2.0 W	3.7 W	4.3 W at 26.4V 5.4 W at 30V ⁽³⁾	5.4 W at 26.4V DC 6.8 W at 30V DC	5.0 W at 30V DC 4.4 W at 26.4V DC (The Watts per point, plus the minimum W, with all points energized.)
Signal delay, max.	On delay: 20.0 ms Off delay: 20.0 ms	On delay: 8.0 ms Off delay: 8.0 ms	On delay: 8.0 ms Off delay: 8.0 ms	On delay: 8.0 ms Off delay: 8.0 ms	On delay: 8.0 ms Off delay: 8.0 ms
Off-state voltage, max.	20V AC	5V DC	5V DC	5V DC	5V DC
Off-state current, max.	2.5 mA	1.5 mA	1.5 mA	1.0 mA	1.5 mA
On-state voltage, min.	79V AC (min.) 132V AC (max.)	10V DC	10V DC	10V DC	10V DC
On-state current	5.0 mA (min.) at 79V AC 47 Hz 12.0 mA (nominal) at 120V AC 60 Hz 16.0 mA (max.) at 132V AC 63 Hz	2.0 mA min. at 10V DC 8.0 mA nominal at 24V DC 12.0 mA max. at 30V DC	2.0 mA min. at 10V DC 8.0 mA nominal at 24V DC 12.0 mA max. at 30V DC	1.6 mA min. at 10V DC 2.0 mA min. at 15V DC 5.7 mA max. at 26.4V DC 6.5 mA max. at 30.0V DC	10 mA at 5V DC
Inrush current, max.	250 mA	Not applicable	Not applicable	Not applicable	250 mA

Input Specifications

Specification	1762-IA8	1762-IQ8	1762-IQ16	1762-IQ32T	1762-IQ80W6
Nominal impedance	12K Ω at 50 Hz 10K Ω at 60 Hz	3K Ω	3K Ω	4.7K Ω	3K Ω
IEC input compatibility	Type 1+	Type 1+	Type 1+	Type 1	Type 1+
Isolated groups	Group 1: inputs 0...7 (internally connected commons)	Group 1: inputs 0...7 (internally connected commons)	Group 1: inputs 0...7; Group 2: inputs 8...15	Group 1: Inputs 0...7; Group 2: Inputs 8...15; Group 3: Inputs 16...23; Group 4: Inputs 24...31	Group 1: inputs 0...3; Group 2: inputs 4...7
Input group to backplane isolation	Verified by one of the following dielectric tests: 1517V AC for 1 s or 2145V DC for 1 s. 132V AC working voltage (IEC Class 2 reinforced insulation)	Verified by one of the following dielectric tests: 1200V ACAC for 1 s or 1697V DC for 1 s. 75V DC working voltage (IEC Class 2 reinforced insulation)	Verified by one of the following dielectric tests: 1200V AC for 1 s or 1697V DC for 1 s. 75V DC working voltage (IEC Class 2 reinforced insulation)	Verified by one of the following dielectric tests: 1200V AC for 2 s or 1697V DC for 2 s. 75V DC working voltage (IEC Class 2 reinforced insulation)	Verified by one of the following dielectric tests: 1200V AC for 1 s or 1697V DC for 1 s. 75V DC working voltage (IEC Class 2 reinforced insulation)
Vendor I.D. code	1				
Product type code	7				
Product code	114	96	97	99	98

(1) Sinking/Sourcing Inputs - Sourcing/sinking describes the current flow between the I/O module and the field device. Sourcing I/O circuits supply (source) current to sinking field devices. Sinking I/O circuits are driven by a current sourcing field device. Field devices connected to the negative side (DC Common) of the field power supply are sinking field devices. Field devices connected to the positive side (+V) of the field supply are sourcing field devices.

(2) See Publication [1762-IN10](#), MicroLogix 1762-IQ16 DC Input Module Installation Instructions, for the derating chart.

(3) Only applicable to Series B and Series C I/O modules.

Output Specifications

Specification	1762-OA8	1762-OB8	1762-OB16	1762-OB32T	1762-OV32T
Shipping weight, approx. (with carton)	215 g (0.48 lbs.)	210 g (0.46 lbs.)	235 g (0.52 lbs.)	200 g (0.44 lbs.)	200 g (0.44 lbs.)
Voltage category	100...240V AC	24V DC	24V DC	24V DC source	24V DC sink
Operating voltage range	85...265V AC at 47...63 Hz	20.4...26.4V DC	20.4...26.4V DC	10.2...26.4V DC	10.2...26.4V DC
Number of outputs	8	8	16	32	32
Bus current draw, max.	115 mA at 5V DC (0.575 W)	115 mA at 5V DC (0.575 W)	175 mA at 5V DC (0.88 W)	175 mA at 5V DC 0 mA at 24V DC	175 mA at 5V DC 0 mA at 24V DC
Heat dissipation, max.	2.9 W	1.61 W	2.9 W at 30 °C (86 °F) 2.1 W at 55 °C (131 °F)	3.4 W at 26.4 DC	2.7 W at 26.4V DC
Signal delay, max. – resistive load	On delay: 1/2 cycle Off delay: 1/2 cycle	On delay: 0.1 ms Off delay: 1.0ms	On delay: 0.1 ms Off delay: 1.0 ms	On delay: 0.5 ms Off delay: 4.0 ms	On delay: 0.5 ms Off delay: 4.0 ms
Off-state leakage current, max.	2 mA at 132V, 2.5 mA at 265V	1.0 mA	1.0 mA	0.1 mA at 26.4V DC	0.1 mA at 26.4V DC
On-state current, min.	10 mA	1.0 mA	1.0 mA	1.0 mA	1.0 mA
On-state voltage drop, max.	1.5V at 0.5 A	1.0V DC	1.0V DC	0.3V DC at 0.5 A	0.3V DC at 0.5A
Continuous current per point, max.	0.25 A at 55 °C (131 °F) 0.5 A at 30 °C (86 °F)	0.5 A at 55 °C (131 °F) 1.0 A at 30 °C (86 °F)	0.5 A at 55 °C (131 °F) 1.0 A at 30 °C (86 °F)	0.5 A at 60 °C (140 °F)	0.5A at 60 °C (140 °F)

Output Specifications

Specification	1762-0A8	1762-0B8	1762-0B16	1762-0B32T	1762-0V32T
Continuous current per common, max.	1.0 A at 55 °C (131 °F) 2.0 A at 30 °C (86 °F)	4.0 A at 55 °C (131 °F) 8.0 A at 30 °C (86 °F)	4.0 A at 55 °C (131 °F) 8.0 A at 30 °C (86 °F)	2.0 A at 60 °C (140 °F)	2.0 A at 60 °C (140 °F)
Continuous current per module, max.	2.0 A at 55 °C (131 °F) 4.0 A at 30 °C (86 °F)	4.0 A at 55 °C; 8.0 A at 30 °C	4.0 A at 55 °C (131 °F) 8.0 A at 30 °C (86 °F)	4.0 A at 60 °C (140 °F)	4.0 A at 60 °C (140 °F)
Surge current, max.	5.0 A (Repeatability is once every 2 s for a duration of 25 ms.)	2.0 A (Repeatability is once every 2 s at 55 °C (131 °F), once every second at 30 °C (86 °F) for a duration of 10 ms.)	2.0 A (Repeatability is once every 2 s at 55 °C (131 °F), once every second at 30 °C (86 °F) for a duration of 10 ms.)	2.0 A (Repeatability is once every 2 s at 60 °C (140 °F) for 10 ms)	2.0 A (Repeatability is once every 2 s at 60 °C (140 °F) for 10 ms)
Isolated groups	Group 1: Outputs 0 to 3 Group 2: Outputs 4 to 7	Group 1: Outputs 0 to 7	Group 1: Outputs 0 to 15	Group 1: Outputs 0...15 Group 2: Outputs 16...31 (internally connected to common)	
Output group to backplane isolation	Verified by one of the following dielectric tests: 1836V AC for 1 s or 2596V DC for 1 s. 265V AC working voltage (IEC Class 2 reinforced insulation)	Verified by one of the following dielectric tests: 1200V AC for 1 s or 1697V DC for 1 s. 75V DC working voltage (IEC Class 2 reinforced insulation)		Verified by one of the following dielectric tests: 1200V AC for 2 s or 1697V DC for 2 s. 75V DC working voltage (IEC Class 2 reinforced insulation)	
Output group to output group isolation	Verified by one of the following dielectric tests: 1836V AC for 1 s or 2596V DC for 1 s. 265V AC working voltage (IEC Class 2 reinforced insulation)	Not applicable		Verified by one of the following dielectric tests: 1200V AC for 2 s or 1697V DC for 2 s. 75V DC working voltage (IEC Class 2 reinforced insulation)	
Vendor I.D. code	1				
Product type code	7				
Product code	119	101	103	100	102

Output Specifications

Specification	1762-0W8	1762-0W16	1762-0X6I	1762-1Q80W6
Shipping weight, approx. (with carton)	228 g (0.50 lbs.)	285 g (0.63 lbs.)	220 g (0.485 lbs)	280 g (0.62 lbs.)
Voltage category	AC/DC normally open relay	AC/DC normally open relay	AC/DC Type C Relay	AC/DC normally open relay
Operating voltage range	5...265V AC 5...125V DC	5...265V AC 5...125V DC	5...265V AC 5...125V DC	5...265V AC 5...125V DC
Number of outputs	8	16	6	6
Bus current draw, max.	80 mA at 5V DC (0.40W) 90 mA at 24V DC (2.16W)	140 mA at 5V DC (0.70W) ⁽¹⁾ 180 mA at 24V DC (4.32W) ⁽¹⁾	110 mA at 5V DC (0.55W) 110 mA at 24V DC (2.64W)	110 mA at 5V DC 80 mA at 24V DC
Heat dissipation, max.	2.9 W	6.1 W ⁽¹⁾	2.8 W	5.0 W at 30V DC 4.4 W at 26.4V DC (The Watts per point, plus the minimum W, with all points energized.)

Output Specifications

Specification	1762-OW8	1762-OW16	1762-OX6I	1762-IQ80W6
Signal delay, max. – resistive load	On Delay: 10 ms Off Delay: 10 ms	On Delay: 10 ms Off Delay: 10 ms	On Delay: 10 ms (max) 6 ms (typical) Off Delay: 20 ms (max) 12 ms (typical)	On-delay: 10 ms (max) Off-delay: 10 ms (max)
Off-state leakage, max.	0 mA	0 mA	0 mA	0 mA
On-state current, min.	10 mA	10 mA	100 mA	10 mA
On-state voltage drop, max.	Not Applicable			
Continuous current per point, max.	2.5 A (Also see “Relay Contact Ratings” on page 191.)		7 A (Also see “Relay Contact Ratings” on page 192.)	2.5 A (Also see “Relay Contact Ratings” on page 191.)
Continuous current per common, max.	8 A	8 A	7 A (Also see “Relay Contact Ratings” on page 183.)	8 A
Continuous current per module, max.	16 A	16 A	30A (Also see Module Load Ratings 1762-OX6I on page 192.)	8A
Surge current, max.	See “Relay Contact Ratings” on page 191.		See “Relay Contact Ratings” on page 192.	See “Relay Contact Ratings” on page 191.
Isolated groups	Group 1: Outputs 0 to 3 Group 2: Outputs 4 to 7	Group 1: Outputs 0 to 7 Group 2: Outputs 8 to 15	All 6 Outputs Individually Isolated.	Group 3: Outputs 0 to 5
Output group to backplane isolation	Verified by one of the following dielectric tests: 1836V AC for 1 s or 2596V DC for 1 s. 265V AC working voltage (IEC Class 2 reinforced insulation)			
Output group to output group isolation	Verified by one of the following dielectric tests: 1836V AC for 1 s or 2596V DC for 1 s. 265V AC working voltage (basic insulation) 150V AC working voltage (IEC Class 2 reinforced insulation)			
Vendor I.D. code	1			
Product type code	7			
Product code	120	121	124	98

(1) Only applicable to Series B and Series C I/O modules.

Relay Contact Ratings (1762-OW8, 1762-OW16, and 1762-IQ80W6)

Maximum Volts	Amperes Continuous	Amperes		Volt-Amperes	
		Make	Break	Make	Break
240V AC	2.5A ⁽¹⁾	7.5A	0.75A	1800 VA	180 VA
120V AC	2.5A ⁽¹⁾	15A	1.5A	1800 VA	180 VA
125V DC	1.0A	0.22A ⁽²⁾		28 VA	
24V DC	2.0A	1.2A ⁽²⁾			

(1) 1.5A above 40 °C (104 °F).

(2) For DC voltage applications, the make/break ampere rating for relay contacts can be determined by dividing 28 VA by the applied DC voltage. For example, 28 VA/48V DC = 0.58A. For DC voltage applications less than 14V, the make/break ratings for relay contacts cannot exceed 2A.

Relay Contact Ratings 1762-OX6I

Volts (max.)	Continuous Amps per Point (max.) ⁽¹⁾	Amperes ⁽³⁾		Voltamperes	
		Make	Break	Make	Break
240V AC	5.0 A	15 A	1.5 A	3600 VA	360 VA
120V AC	7.0 A ⁽²⁾	30 A	3.0 A		
125V DC	2.5 A	0.4 A		50 VA ⁽⁴⁾	
24V DC	7.0 A ⁽²⁾	7.0 A		168 VA ⁽⁴⁾	

(1) The continuous current per module must be limited so the module power does not exceed 1440VA.

(2) 6 A in ambient temperatures above 40 °C (104. °F)

(3) **Surge Suppression** – Connecting surge suppressors across your external inductive load will extend the life of the relay contacts. For additional details, refer to *Industrial Automation Wiring and Grounding Guidelines*, publication 1770-4.1.

(4) DC Make/Break Voltamperes must be limited to 50 VA for DC voltages between 28V DC and 125V DC. DC Make/Break Voltamperes below 28V DC are limited by the 7 A Make/Break current limit.

Module Load Ratings 1762-OX6I

Volts (max.)	Controlled Load (Current) per Module (max.)
240V AC	6 A
120V AC	12 A ⁽¹⁾
125V DC	11.5 A
24V DC	30 A ⁽²⁾

(1) Current per relay limited to 6 A at ambient temperatures above 40 °C (104. °F).

(2) 24 A in ambient temperatures above 40 °C (104. °F). Limited by ambient temperature and the number of relays controlling loads. See below.

Relays Used vs. Maximum Current per Relay (24V DC) 1762-OX6I

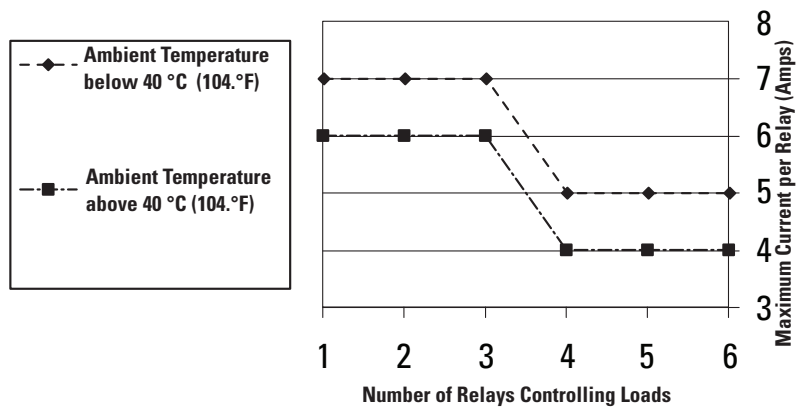

Analog Modules

Common Specifications

Specification	1762-IF20F2, 1762-IF4, 1762-IR4, 1762-IT4, and 1762-OF4
Dimensions	90 mm (height) x 87 mm (depth) x 40 mm (width) height including mounting tabs is 110 mm 3.54 in. (height) x 3.43 in. (depth) x 1.58 in. (width) height including mounting tabs is 4.33 in.
Temperature, storage	-40...85 °C (-40...185 °F)
Temperature, operating	-20...65 °C (-4...149 °F) ⁽¹⁾
Operating humidity	5...95% non-condensing
Operating altitude	2000 m (6561 ft)
Vibration	Operating: 10...500 Hz, 5 g, 0.030 in. max. peak-to-peak
Shock	Operating: 30 g
Module power LED	On: indicates power is applied.
Recommended cable	Belden 8761 (shielded) (For 1762-IT4, Shielded thermocouple extension wire for the specific type of thermocouple you are using. Follow thermocouple manufacturer's recommendations.)

(1) Refer to the module's Installation Instruction for exact operating temperature range.

Environmental Specifications

Attribute	Value
Emissions	IEC 61000-6-4
ESD immunity	IEC 61000-4-2: 6 kV contact discharges 8 kV air discharges
Radiated RF immunity	IEC 61000-4-3: 10V/m with 1 kHz sine-wave 80% AM from 80...1000 MHz 3V/m with 1 kHz sine-wave 80% AM from 1.4...2.0 GHz 1V/m with 1 kHz sine-wave 80% AM from 2.0...2.7 GHz
EFT/B immunity	IEC 61000-4-4: ±2 kV @ 5 kHz on signal ports
Surge transient immunity	IEC 61000-4-5: ±1kV line-earth(CM) on shielded ports
Conducted RF immunity	IEC 61000-4-6: 10V rms with 1 Hz sine-wave 80% AM from 150 kHz...80 MHz ⁽¹⁾

(1) For grounded thermocouples, the 10V level is reduced to 3V.

Certifications

Certification (when product is marked) ⁽¹⁾	Value
UL	UL Listed for Class I, Division 2 Group A, B, C, D Hazardous Locations
c-UL	UL Listed for Class I, Division 2 Group A, B, C, D Hazardous Locations, certified for Canada.
CE	European Union 2014/30/EU EMC Directive, compliant with: <ul style="list-style-type: none"> EN 61000-6-2; Industrial Immunity EN 61000-6-4; Industrial Emissions EN 61131-2; Programmable Controllers (Clause 8, Zone A & B)
RCM	Australian Radiocommunications Act, compliant with: AS/NZS CISPR 11; Industrial Emissions
EAC	Russian Customs Union TR CU 020/2011 EMC Technical Regulation
KC	Korean Registration of Broadcasting and Communications Equipment, compliant with: Article 58-2 of Radio Waves Act, Clause 3

(1) See the Product Certification link at <http://www.rockwellautomation.com/products/certification/> for Declaration of Conformity, Certificates, and other certification details.

General Specifications

Specification	1762-IF20F2	1762-IF4	1762-OF4	1762-IR4	1762-IT4
Shipping weight, approx. (with carton)	240 g (0.53 lbs.)		235 g (0.517 lbs.)	260 g (0.57 lbs.)	220 g (0.53 lbs.)
Bus current draw, max.	40 mA at 5V DC 105 mA at 24V DC	40 mA at 5V DC 50 mA at 24V DC	40 mA at 5V DC 165 mA at 24V DC	40 mA at 5V DC 50 mA at 24V DC	40 mA at 5V DC 50 mA at 24V DC
Analog normal operating range	Voltage: 0...10V DC Current: 4...20 mA	Voltage: -10...+10V DC Current: 4...20 mA	Voltage 0...10V DC Current: 4...20 mA	NA	NA
Full scale ⁽¹⁾ analog ranges	Voltage: 0...10.5V DC Current: 0...21 mA	Voltage: -10.5...+10.5V DC Current: -21...+21 mA	Voltage: 0...10.5V DC Current: 0...21 mA	NA	NA
Resolution	12 bits (unipolar)	15 bits (bipolar) ⁽⁴⁾	12 bits (unipolar)	Input filter and configuration dependent	15 bits plus sign
Repeatability ⁽²⁾	±0.12% ⁽⁴⁾	±0.12% ⁽⁴⁾	±0.12% ⁽⁴⁾	±0.1 °C (±0.18 °F) for Ni and NiFe ±0.2 °C (±0.36 °F)...±0.2 °C (±0.36 °F) for other RTD inputs ±0.04 ohm for 150 ohm resistances ±0.2 ohm for other resistances	See Table 198
Input and output group to system isolation	30V AC/30V DC rated working voltage ⁽³⁾ (N.E.C. Class 2 required) (IEC Class 2 reinforced insulation) type test: 500V AC or 707V DC for 1 minute		30V AC/30V DC rated working voltage (IEC Class 2 reinforced insulation) type test: 500V AC or 707V DC for 1 minute	30V AC/30V DC working voltage type test: 500V AC or 707V DC for 1 minute	30V AC/30V DC working voltage qualification test: 720V DC for 1 minute
Vendor I.D. code	1	1	1	1	1
Product type code	10	10	10	10	10
Product code	75	67	66	65	64

(1) The over- or under-range flag comes on when the normal operating range (over/under) is exceeded. The module continues to convert the analog input up to the maximum full scale range.

(2) Repeatability is the ability of the module to register the same reading in successive measurements for the same signal.

(3) Rated working voltage is the maximum continuous voltage that can be applied at the terminals with respect to earth ground.

(4) Only applicable to Series B and Series C I/O models.

Input Specifications

Specification	1762-IF20F2	1762-IF4	1762-IR4	1762-IT4
Number of inputs	2 differential (unipolar)	4 differential (bipolar)	4	4 input channels plus 1 CJC sensor
Update time (typical)	2.5 ms	130, 250, 290, 450, 530 ms (selectable)	Input filter and configuration dependent	NA
A/D converter type	Successive approximation	Successive approximation	Delta-Sigma	Delta-Sigma
Common mode voltage range ⁽¹⁾	±27V	±27V	NA	±10V
Common mode rejection ⁽²⁾	> 55 dB at 50 and 60 Hz	> 55 dB at 50 and 60 Hz	>110 dB at 50 Hz (with 10 or 50 Hz filter) >110 dB at 60 Hz (with 10 or 60 Hz filter)	>110 dB at 50 Hz (with 10 or 50 Hz filter) >110 dB at 60 Hz (with 10 or 60 Hz filter)
Non-linearity (in percent full scale)	±0.12% ⁽⁴⁾	±0.12% ⁽⁴⁾	±0.05%	NA
Typical overall accuracy ⁽³⁾	±0.55% full scale at -20...65 °C ⁽⁴⁾ ±0.3% full scale at 25 °C	±0.32% full scale at -20...65 °C ⁽⁴⁾ ±0.24% full scale at 25 °C	±0.5 °C (F °) for Pt 385	NA
Input impedance	Voltage Terminal: 200 KΩ Current Terminal: 250 Ω	Voltage Terminal: 200 KΩ Current Terminal: 275 Ω	>10 MΩ	>10 MΩ
Current input protection	±32 mA	±32 mA	NA	NA
Voltage input protection	±30V	±30V	NA	NA
Channel diagnostics	Over or under range or open circuit condition by bit reporting for analog inputs.	Over or under range or open circuit condition by bit reporting for analog inputs.	Over or under range or open circuit condition by bit reporting for analog inputs.	Over or under range or open circuit condition by bit reporting for analog inputs.

(1) For proper operation, both the plus and minus input terminals must be within ±27V (±10V for 1762-IT4) of analog common.

(2) $V_{cm} = 1 V_{pk-pk AC}$

(3) $V_{cm} = 0$ (includes offset, gain, non-linearity and repeatability error terms)

(4) Only applicable to Series B and Series C I/O modules.

Input Specifications 1762-IR4

Specification	1762-IR4		
Input types	<ul style="list-style-type: none"> •100 Ω Platinum 385 •200 Ω Platinum 385 •500 Ω Platinum 385 •1,000 Ω Platinum 385 •100 Ω Platinum 3916 •200 Ω Platinum 3916 •500 Ω Platinum 3916 •1,000 Ω Platinum 3916 •10 Ω Copper 426 •120 Ω Nickel 672 •120 Ω Nickel 618 •604 Ω Nickel-Iron 518 •0...150 Ω •0...500 Ω •0...1,000 Ω •0...3,000 Ω 		
Heat dissipation	1.5 Total Watts (The Watts per point, plus the minimum Watts, with all points enabled.)		
Normal mode rejection ratio	70 dB minimum at 50 Hz with the 10 or 50 Hz filter selected 70 dB minimum at 60 Hz with the 10 or 60 Hz filter selected		
Typical accuracy [Autocalibration enabled] at 25 °C (77 °F) ambient with module operating temperature at 25 °C (77 °F) ⁽¹⁾	<table style="width: 100%; border: none;"> <tr> <td style="width: 50%; border: none;"> <ul style="list-style-type: none"> ±0.5 °C (°F) for Pt 385 ±0.4 °C (°F) for Pt 3916 ±0.2 °C (°F) for Ni ±0.3 °C (°F) for NiFe ±0.6 °C (°F) for Cu </td> <td style="width: 50%; border: none;"> <ul style="list-style-type: none"> ±0.15 Ω for 150 Ω range ±0.5 Ω for 500 Ω range ±1.0 Ω for 1,000 Ω range ±1.5 Ω for 3,000 Ω range </td> </tr> </table>	<ul style="list-style-type: none"> ±0.5 °C (°F) for Pt 385 ±0.4 °C (°F) for Pt 3916 ±0.2 °C (°F) for Ni ±0.3 °C (°F) for NiFe ±0.6 °C (°F) for Cu 	<ul style="list-style-type: none"> ±0.15 Ω for 150 Ω range ±0.5 Ω for 500 Ω range ±1.0 Ω for 1,000 Ω range ±1.5 Ω for 3,000 Ω range
<ul style="list-style-type: none"> ±0.5 °C (°F) for Pt 385 ±0.4 °C (°F) for Pt 3916 ±0.2 °C (°F) for Ni ±0.3 °C (°F) for NiFe ±0.6 °C (°F) for Cu 	<ul style="list-style-type: none"> ±0.15 Ω for 150 Ω range ±0.5 Ω for 500 Ω range ±1.0 Ω for 1,000 Ω range ±1.5 Ω for 3,000 Ω range 		
Typical accuracy [Autocalibration enabled] at 0...55 °C (32...131 °F) ⁽¹⁾	<table style="width: 100%; border: none;"> <tr> <td style="width: 50%; border: none;"> <ul style="list-style-type: none"> ±0.9 °C (°F) for Pt 385 ±0.8 °C (°F) for Pt 3916 ±0.4 °C (°F) for Ni ±0.5 °C (°F) for NiFe ±1.1 °C (°F) for Cu </td> <td style="width: 50%; border: none;"> <ul style="list-style-type: none"> ±0.25 Ω for 150 Ω range ±0.8 Ω for 500 Ω range ±1.5 Ω for 1,000 Ω range ±2.5 Ω for 3,000 Ω range </td> </tr> </table>	<ul style="list-style-type: none"> ±0.9 °C (°F) for Pt 385 ±0.8 °C (°F) for Pt 3916 ±0.4 °C (°F) for Ni ±0.5 °C (°F) for NiFe ±1.1 °C (°F) for Cu 	<ul style="list-style-type: none"> ±0.25 Ω for 150 Ω range ±0.8 Ω for 500 Ω range ±1.5 Ω for 1,000 Ω range ±2.5 Ω for 3,000 Ω range
<ul style="list-style-type: none"> ±0.9 °C (°F) for Pt 385 ±0.8 °C (°F) for Pt 3916 ±0.4 °C (°F) for Ni ±0.5 °C (°F) for NiFe ±1.1 °C (°F) for Cu 	<ul style="list-style-type: none"> ±0.25 Ω for 150 Ω range ±0.8 Ω for 500 Ω range ±1.5 Ω for 1,000 Ω range ±2.5 Ω for 3,000 Ω range 		
Accuracy drift at 0...55 °C (32...131 °F)	<table style="width: 100%; border: none;"> <tr> <td style="width: 50%; border: none;"> <ul style="list-style-type: none"> ±0.026 °C/°C (0.026 °F/°F) for Pt 385 ±0.023 °C/°C (0.023 °F/°F) for Pt 3916 ±0.012 °C/°C (0.012 °F/°F) for Ni ±0.015 °C/°C (0.015 °F/°F) for NiFe ±0.032 °C/°C (0.032 °F/°F) for Cu </td> <td style="width: 50%; border: none;"> <ul style="list-style-type: none"> ±0.007 Ω/°C (0.012 Ω/°F) for 150 Ω range ±0.023 Ω/°C (0.041 Ω/°F) for 500 Ω range ±0.043 Ω/°C (0.077 Ω/°F) for 1,000 Ω range ±0.07 2Ω/°C (0.130 Ω/°F) for 3,000 Ω range </td> </tr> </table>	<ul style="list-style-type: none"> ±0.026 °C/°C (0.026 °F/°F) for Pt 385 ±0.023 °C/°C (0.023 °F/°F) for Pt 3916 ±0.012 °C/°C (0.012 °F/°F) for Ni ±0.015 °C/°C (0.015 °F/°F) for NiFe ±0.032 °C/°C (0.032 °F/°F) for Cu 	<ul style="list-style-type: none"> ±0.007 Ω/°C (0.012 Ω/°F) for 150 Ω range ±0.023 Ω/°C (0.041 Ω/°F) for 500 Ω range ±0.043 Ω/°C (0.077 Ω/°F) for 1,000 Ω range ±0.07 2Ω/°C (0.130 Ω/°F) for 3,000 Ω range
<ul style="list-style-type: none"> ±0.026 °C/°C (0.026 °F/°F) for Pt 385 ±0.023 °C/°C (0.023 °F/°F) for Pt 3916 ±0.012 °C/°C (0.012 °F/°F) for Ni ±0.015 °C/°C (0.015 °F/°F) for NiFe ±0.032 °C/°C (0.032 °F/°F) for Cu 	<ul style="list-style-type: none"> ±0.007 Ω/°C (0.012 Ω/°F) for 150 Ω range ±0.023 Ω/°C (0.041 Ω/°F) for 500 Ω range ±0.043 Ω/°C (0.077 Ω/°F) for 1,000 Ω range ±0.07 2Ω/°C (0.130 Ω/°F) for 3,000 Ω range 		
Excitation current source	0.5 mA and 1.0 mA selectable per channel		
Open-circuit detection time ⁽²⁾	6...1212 ms		
Input channel configuration	Via configuration software screen or the user program (by writing a unique bit pattern into the module's configuration file). See your controller's user manual to determine if user program configuration is supported.		
Calibration	The module performs autocalibration on channel enable and on a configuration change between channels. You can also program the module to calibrate every five minutes.		

Input Specifications 1762-IR4

Specification	1762-IR4
Maximum overload at input terminals	±35V DC continuous
Cable impedance, max.	25 Ω (Operating with >25 Ω will reduce accuracy.)
Channel to channel isolation	±10V DC

(1) Accuracy is dependent upon the Analog/Digital converter filter rate selection, excitation current selection, data format, and input noise.

(2) Open-circuit detection time is equal to channel update time.

Input Specifications 1762-IT4

Specification	Value
Heat dissipation	1.5 Total Watts (The Watts per point, plus the minimum Watts, with all points energized.)
Response speed per channel	Input filter and configuration dependent.
Rated working voltage ⁽¹⁾	30V AC/30V DC
Normal mode rejection ratio	85 dB (minimum) at 50 Hz (with 10 Hz or 50 Hz filter) 85 dB (minimum) at 60 Hz (with 10 Hz or 60 Hz filter)
Cable impedance, max.	25 Ω (for specified accuracy)
Open-circuit detection time	7 ms...1.515 s ⁽²⁾
Calibration	The module performs autocalibration upon power-up and whenever a channel is enabled. You can also program the module to calibrate every five minutes.
CJC accuracy	±1.3 °C (±2.34 °F)
Maximum overload at input terminals	±35V DC continuous ⁽³⁾
Input channel configuration	via configuration software screen or the user program (by writing a unique bit pattern into the module's configuration file).

(1) Rated working voltage is the maximum continuous voltage that can be applied at the input terminal, including the input signal and the value that floats above ground potential (for example, 30V DC input signal and 20V DC potential above ground).

(2) Open-circuit detection time is equal to the module scan time, which is based on the number of enabled channels, the filter frequency of each channel, and whether cyclic calibration is enabled..

(3) Maximum current input is limited due to input impedance.

1762-IT4 Repeatability at 25 °C (77 °F)^{(1) (2)}

Input Type	Repeatability for 10 Hz Filter
Thermocouple J	±0.1 °C [±0.18 °F]
Thermocouple N (-110...1300 °C [-166...2372 °F])	±0.1 °C [±0.18 °F]
Thermocouple N (-210...-110 °C [-346...-166 °F])	±0.25 °C [±0.45 °F]
Thermocouple T (-170...400 °C [-274...752 °F])	±0.1 °C [±0.18 °F]
Thermocouple T (-270...-170 °C [-454...-274 °F])	±1.5 °C [±2.7 °F]
Thermocouple K (-270...1370 °C [-454 °F...2498 °F])	±0.1 °C [±0.18 °F]
Thermocouple K (-270...-170 °C [-454...-274 °F])	±2.0 °C [±3.6 °F]
Thermocouple E (-220...1000 °C [-364...1832 °F])	±0.1 °C [±0.18 °F]
Thermocouple E (-270...-220 °C [-454...-364 °F])	±1.0 °C [±1.8 °F]
Thermocouples S and R	±0.4 °C [±0.72 °F]
Thermocouple C	±0.2 °C [±0.36 °F]
Thermocouple B	±0.7 °C [±1.26 °F]
±50 mV	±6 µV
±100 mV	±6 µV

(1) Repeatability is the ability of the input module to register the same reading in successive measurements for the same input signal.

(2) Repeatability at any other temperature in the 0...60 °C (32...140 °F) range is the same as long as the temperature is stable.

1762-IT4 Accuracy

Input Type ⁽¹⁾	With Autocalibration Enabled		Without Autocalibration
	Accuracy for 10 Hz, 50 Hz and 60 Hz Filters (max.)		Maximum Temperature Drift ^{(2) (2)}
	at 25 °C [77 °F] Ambient	at 0...60 °C [32...140 °F] Ambient	at 0...60 °C [32...140 °F] Ambient
Thermocouple J (-210...1200 °C [-346...2192 °F])	±0.6 °C [±1.1 °F]	±0.9 °C [±1.7 °F]	±0.0218 °C/°C [±0.0218 °F/°F]
Thermocouple N (-200...1300 °C [-328...2372 °F])	±1 °C [±1.8 °F]	±1.5 °C [±2.7 °F]	±0.0367 °C/°C [±0.0367 °F/°F]
Thermocouple N (-210...-200 °C [-346...-328 °F])	±1.2 °C [±2.2 °F]	±1.8 °C [±3.3 °F]	±0.0424 °C/°C [±0.0424 °F/°F]
Thermocouple T (-230...400 °C [-382...752 °F])	±1 °C [±1.8 °F]	±1.5 °C [±2.7 °F]	±0.0349 °C/°C [±0.0349 °F/°F]
Thermocouple T (-270...-230 °C [-454...-382 °F])	±5.4 °C [±9.8 °F]	±7.0 °C [±12.6 °F]	±0.3500 °C/°C [±0.3500 °F/°F]
Thermocouple K (-230...1370 °C [-382...2498 °F])	±1 °C [±1.8 °F]	±1.5 °C [±2.7 °F]	±0.4995 °C/°C [±0.4995 °F/°F]
Thermocouple K (-270...-225 °C [-454...-373 °F])	±7.5 °C [±13.5 °F]	±10 °C [±18 °F]	±0.0378 °C/°C [±0.0378 °F/°F]
Thermocouple E (-210...1000 °C [-346...1832 °F])	±0.5 °C [±0.9 °F]	±0.8 °C [±1.5 °F]	±0.0199 °C/°C [±0.0199 °F/°F]
Thermocouple E (-270...-210 °C [-454...-346 °F])	±4.2 °C [±7.6 °F]	±6.3 °C [±11.4 °F]	±0.2698 °C/°C [±0.2698 °F/°F]
Thermocouple R	±1.7 °C [±3.1 °F]	±2.6 °C [±4.7 °F]	±0.0613 °C/°C [±0.0613 °F/°F]
Thermocouple S	±1.7 °C [±3.1 °F]	±2.6 °C [±4.7 °F]	±0.0600 °C/°C [±0.0600 °F/°F]
Thermocouple C	±1.8 °C [±3.3 °F]	±3.5 °C [±6.3 °F]	±0.0899 °C/°C [±0.0899 °F/°F]

1762-IT4 Accuracy

Input Type ⁽¹⁾	With Autocalibration Enabled		Without Autocalibration
	Accuracy for 10 Hz, 50 Hz and 60 Hz Filters (max.)		Maximum Temperature Drift ⁽²⁾ (2)
	at 25 °C [77 °F] Ambient	at 0...60 °C [32...140 °F] Ambient	at 0...60 °C [32...140 °F] Ambient
Thermocouple B	±3.0 °C [±5.4 °F]	±4.5 °C [±8.1 °F]	±0.1009 °C/°C [±0.1009 °F/°F]
±50 mV	±15 µV	±25 µV	±0.44µV/°C [±0.80µV/°F]
±100 mV	±20 µV	±30 µV	±0.69µV/°C [±01.25µV/°F]

(1) The module uses the National Institute of Standards and Technology (NIST) ITS-90 standard for thermocouple linearization.

(2) Temperature drift with autocalibration is slightly better than without autocalibration.

TIP

For more detailed 1762-IT4 accuracy information, see publication [1762-UM002](#).

Output Specifications

Specification	1762-IF20F2	1762-OF4
Number of outputs	2 single-ended (unipolar)	4 single-ended (unipolar) ⁽²⁾
Update time (typical)	4.5 ms	
D/A converter type	Resistor string	R-2R Ladder Voltage Switching
Resistive load on current output	0...500 Ω (includes wire resistance)	0...500 Ω (includes wire resistance)
Load range on voltage output	> 1kΩ	> 1KΩ
Reactive load, current output	< 0.1 mH	< 0.1 mH
Reactive load, voltage output	< 1 µF	< 1 µF
Typical overall accuracy ⁽¹⁾	±1.17% full scale at -20...65 °C ⁽²⁾ ±0.5% full scale at 25 °C	±1.17% full scale at -20...65 °C ⁽²⁾ ±0.5% full scale at 25 °C
Output ripple range 0...500 Hz (referred to output range)	< ±0.1%	< ±0.1%
Non-linearity (in percent full scale)	< ±0.59% ⁽²⁾	< ±0.59% ⁽²⁾
Open and short-circuit protection	Continuous	Continuous
Output protection	±32 mA	±32 mA

(1) Includes offset, gain, non-linearity and repeatability error terms.

(2) Only applicable to Series B and Series C I/O modules.

Valid Input/Output Data Word Formats/Ranges for 1762-IF20F2

Normal Operating Range	Full Scale Range	RAW/Proportional Data	Scaled-for-PID
0...10V DC	10.5V DC	32760	16380
	0.0V DC	0	0
4...20 mA	21.0 mA	32760	16380
	20.0 mA	31200	15600
	4.0 mA	6240	3120
	0.0 mA	0	0

Replacement Parts

This chapter contains the following information:

- a table of MicroLogix 1400 replacement parts
- procedure for replacing the lithium battery

MicroLogix 1400 Replacement Kits

The table below provides a list of replacement parts and their catalog number.

Description	Catalog Number
Lithium Battery (See page 201.)	1747-BA

Lithium Battery (1747-BA)

IMPORTANT When the controller's Battery Low indicator is lit, check whether the battery wire connector is connected correctly or replace the replaceable battery with a new one immediately. When the indicator turns on, it means that either the battery is disconnected, or that the battery requires replacement. The controller is designed to operate for up to 2 weeks, from the time that the indicator first turns on. We recommend that you replace the battery immediately when the indicator turns on.

Installation

Follow the procedure below to ensure proper replaceable battery installation.

1. Insert a battery into the battery pocket with wires facing up.
2. Insert the battery wire connector into the battery connector.
3. Secure the battery connector wires around the 1762 expansion bus connector as shown below.

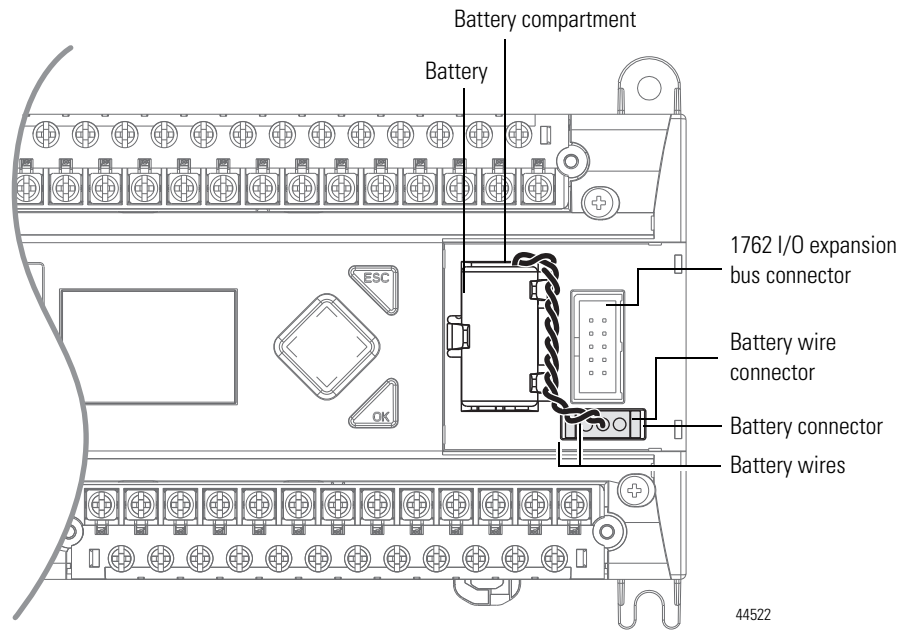

Battery Handling

Follow the procedure below to ensure proper battery operation and reduce personnel hazards.

- Use only for the intended operation.
- Do not ship or dispose of cells except according to recommended procedures.
- Do not ship on passenger aircraft.



ATTENTION:

- Do not charge the batteries. An explosion could result or the cells could overheat causing burns.
 - Do not open, puncture, crush, or otherwise mutilate the batteries. A possibility of an explosion exists and/or toxic, corrosive, and flammable liquids would be exposed.
 - Do not incinerate or expose the batteries to high temperatures. Do not attempt to solder batteries. An explosion could result.
 - Do not short positive and negative terminals together. Excessive heat can build up and cause severe burns.
-

Storage

Store lithium batteries in a cool, dry environment, typically 20 °C...25 °C (68°F...77°F) and 40%...60% humidity. Store the batteries and a copy of the battery instruction sheet in the original container, away from flammable materials.

Transportation

One or Two Batteries

Each battery contains 0.23 g of lithium. Therefore, up to two batteries can be shipped together within the United States without restriction. Regulations governing shipment to or within other countries may differ.

Three or More Batteries

Procedures for the transportation of three or more batteries shipped together within the United States are specified by the Department of Transportation (DOT) in the Code of Federal Regulations, CFR49, "Transportation." An exemption to these regulations, DOT - E7052, covers the transport of certain hazardous materials classified as flammable solids. This exemption authorizes transport of lithium batteries by motor vehicle, rail freight, cargo vessel, and

cargo-only aircraft, providing certain conditions are met. Transport by passenger aircraft is not permitted.

A special provision of DOT-E7052 (11th Rev., October 21, 1982, par. 8-a) provides that:

“Persons that receive cell and batteries covered by this exemption may reship them pursuant to the provisions of 49 CFR 173.22a in any of these packages authorized in this exemption including those in which they were received.”

The Code of Federal Regulations, 49 CFR 173.22a, relates to the use of packaging authorized under exemptions. In part, it requires that you must maintain a copy of the exemption at each facility where the packaging is being used in connection with shipment under the exemption.

Shipment of depleted batteries for disposal may be subject to specific regulation of the countries involved or to regulations endorsed by those countries, such as the IATA Articles Regulations of the International Air Transport Association, Geneva, Switzerland.

IMPORTANT

Regulations for transportation of lithium batteries are periodically revised. See <http://www.dot.gov> for the latest shipping information.

Disposal



ATTENTION: Do not incinerate or dispose of lithium batteries in general trash collection. Explosion or violent rupture is possible. Batteries should be collected for disposal in a manner to prevent against short-circuiting, compacting, or destruction of case integrity and hermetic seal.

For disposal, batteries must be packaged and shipped in accordance with transportation regulations, to a proper disposal site. The U.S. Department of Transportation authorizes shipment of “Lithium batteries for disposal” by motor vehicle only in regulation 173.1015 of CFR 49 (effective January 5, 1983). For additional information contact:

U.S. Department of Transportation
Research and Special Programs Administration
400 Seventh Street, S.W.
Washington, D.C. 20590

Although the Environmental Protection Agency at this time has no regulations specific to lithium batteries, the material contained may be considered toxic, reactive, or corrosive. The person disposing of the material is responsible for any hazard created in doing so. State and local regulations may exist regarding the disposal of these materials.

For a lithium battery product safety data sheet, contact the manufacturer:

Sanyo Energy Corporation
2001 Sanyo Avenue
San Diego, CA 92173
(619) 661-4801

Tadarand U.S. Battery Division
2 Seaview Blvd.
Port Washington, NY 11050
(516) 621-4980

Notes:

Troubleshooting Your System

This chapter describes how to troubleshoot your controller. Topics include:

- understanding the controller status indicators
- controller error recovery model
- analog expansion I/O diagnostics and troubleshooting
- calling Rockwell Automation for assistance

Understanding the Controller Status Indicators

The MicroLogix 1400 provides three groups of status indicators:

- the status LEDs on the top of the controller,
- the status indicators on the LCD
- the I/O status indicators on the LCD.

Together they provide a mechanism to determine the current status of the controller if a programming device is not present or available.

Controller Status LED Indicators

Figure 3 - Controller LED Location



44607

Controller LED Indicators

LED	Color	Indicates
POWER	off	No input power, or power error condition
	green	Power on
RUN	off	Not executing the user program
	green	Executing the user program in run mode
	green flashing	Memory module transfer occurring

Controller LED Indicators

LED	Color	Indicates
FAULT	off	No fault detected
	red flashing	Application fault detected
	red	Controller hardware faulted
FORCE	off	No forces installed
	amber	Forces installed
	amber flashing	Forces installed in force files but forcing is disabled.

Status Indicators on the LCD

Figure 4 - Status Indicators on the LCD

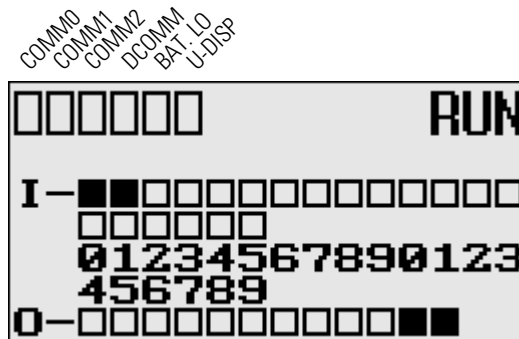

Status Indicators on the LCD

Indicator	Color	Indicates
COMM 0	off (empty rectangle)	Not transmitting via RS-232/485 port (Channel 0)
	on (solid rectangle)	Transmitting via RS-232/485 port (Channel 0)
COMM 1	off (empty rectangle)	Not transmitting via Ethernet port (Channel 1)
	on (solid rectangle)	Transmitting via Ethernet port (Channel 1)
COMM 2	off (empty rectangle)	Not transmitting via RS-232 port (Channel 2)
	on (solid rectangle)	Transmitting via RS-232 port (Channel 2)
DCOMM ⁽¹⁾	off (empty rectangle)	Configured communications (Channel 0)
	on (solid rectangle)	Default communications (Channel 0)
BAT. LO	off (empty rectangle)	Battery level is acceptable
	on (solid rectangle)	Battery low
U-DISP	off (empty rectangle)	Default display mode
	on (solid rectangle)	Customized display mode

⁽¹⁾ When using a MicroLogix 1400 controller, the DCOMM LED applies only to Channel 0.

I/O Status Indicators on the LCD

Figure 5 - I/O Status Indicators on the LCD

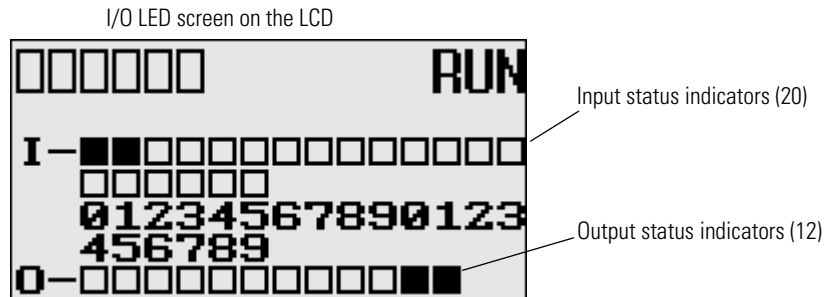

I/O Status Indicators on the LCD

Indicator	Color	Indicates
INPUTS ⁽¹⁾	off (empty rectangle)	Input is not energized
	on (solid rectangle)	Input is energized (terminal status)
OUTPUTS	off (empty rectangle)	Output is not energized
	on (solid rectangle)	Output is energized (logic status)

⁽¹⁾ To view the status of inputs and outputs on the LCD, you need to enter the I/O LED mode screen using the LCD menu. See I/O Status on page 5-109 for more information.

Normal Operation

The POWER and RUN LEDs are On. If forcing is enabled and forces are installed in I/O force files, the FORCE LED turns on and remains on until all forces are removed. And if forcing is disabled and forces are installed in I/O force files, the FORCE LED flashes and remains flashing until forces are removed from I/O force files.

Error Conditions

If an error exists within the controller, the controller LEDs operate as described in the following table.

If the LEDS indicate:	The Following Error Exists	Probable Cause	Recommended Action
All LEDs off	No input power or power supply error	No line Power	Verify proper line voltage and connections to the controller.
		Power Supply Overloaded	This problem can occur intermittently if power supply is overloaded when output loading and temperature varies.
Power and FAULT LEDs on solid	Hardware faulted	Processor Hardware Error	Cycle power. Contact your local Allen-Bradley representative if the error persists.
		Loose Wiring	Verify connections to the controller.
Power LED on and FAULT LED flashing	Application fault	Hardware/Software Major Fault Detected	For error codes and Status File information, see <i>MicroLogix 1400 Programmable Controllers Instruction Set Reference Manual</i> , Publication 1766-RM001 .
RUN FORCE FAULT LEDs all flashing	Operating system fault	Missing or Corrupt Operating System	See Recovering from Missing or Corrupt OS State on page D-235.

Controller Error Recovery Model

Use the following error recovery model to help you diagnose software and hardware problems in the micro controller. The model provides common questions you might ask to help troubleshoot your system. Refer to the recommended pages within the model for further help.

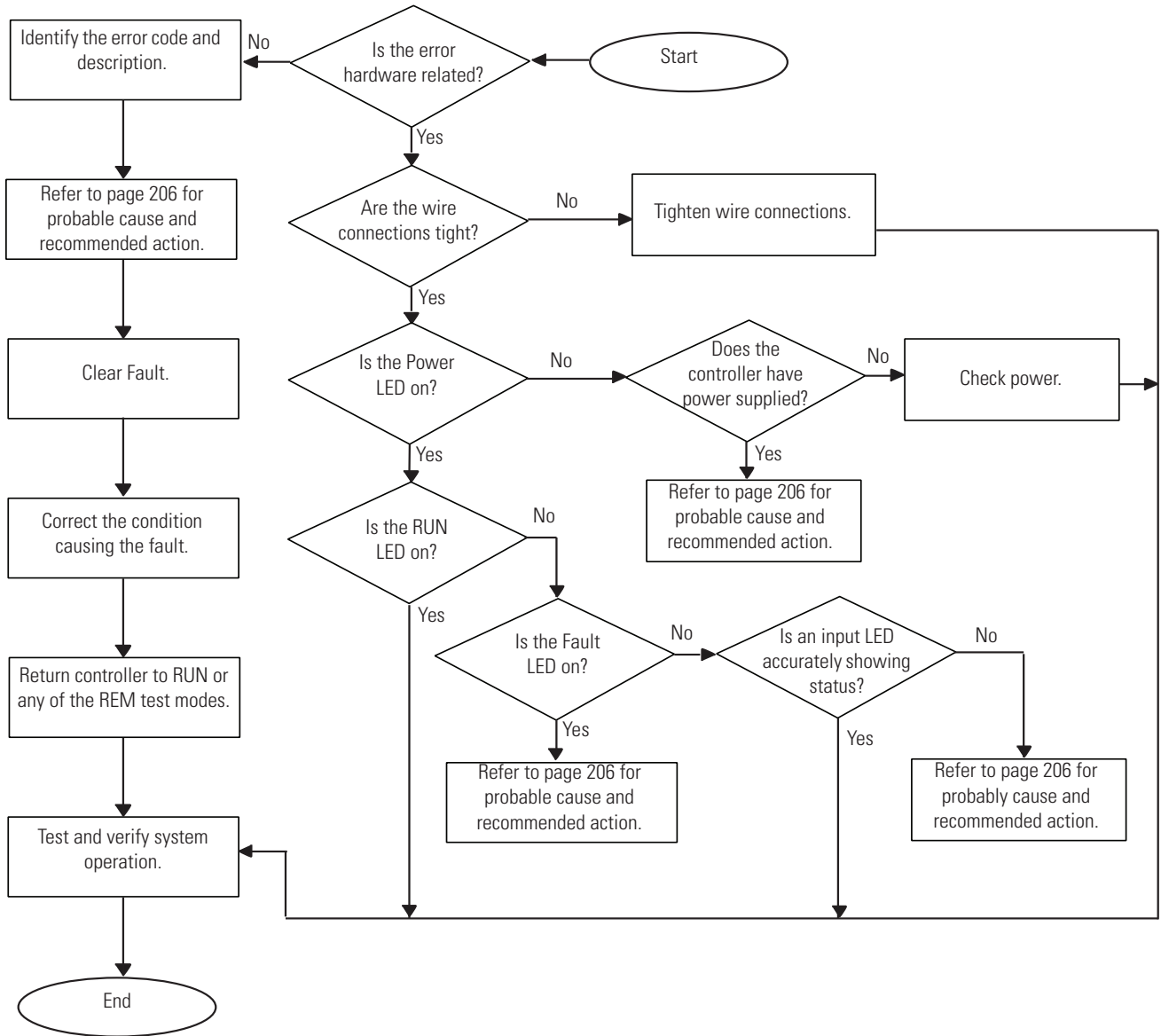

Analog Expansion I/O Diagnostics and Troubleshooting

Module Operation and Channel Operation

The module performs operations at two levels:

- module level
- channel level

Module-level operations include functions such as power-up, configuration, and communication with the controller.

Internal diagnostics are performed at both levels of operation. Both module hardware and channel configuration error conditions are reported to the controller. Channel over-range or under-range conditions are reported in the module's input data table. Module hardware errors are reported in the controller's I/O status file. Refer to the MicroLogix 1400 Programmable Controllers Instruction Set Reference Manual, publication [1766-RM001](#) for more information.

When a fault condition is detected, the analog outputs are reset to zero.

Power-up Diagnostics

At module power-up, a series of internal diagnostic tests are performed.

Module Status LED State Table

If module status LED is	Indicated condition	Corrective action
On	Proper Operation	No action required.
Off	Module Fault	Cycle power. If condition persists, replace the module. Call your local distributor or Allen-Bradley for assistance.

Critical and Non-Critical Errors

Non-critical module errors are recoverable. Channel errors (over-range or under-range errors) are non-critical. Non-critical error conditions are indicated in the module input data table. Non-critical configuration errors are indicated by the extended error code. See Extended Error Codes for 1762-IF2OF2 on page 214.

Critical module errors are conditions that prevent normal or recoverable operation of the system. When these types of errors occur, the system leaves the run mode of operation. Critical module errors are indicated in Extended Error Codes for 1762-IF2OF2 on page 214.

Module Error Definition Table

Analog module errors are expressed in two fields as four-digit Hex format with the most significant digit as “don’t care” and irrelevant. The two fields are “Module Error” and “Extended Error Information”. The structure of the module error data is shown below.

Module Error Table

“Don’t Care” Bits				Module Error			Extended Error Information								
15	14	13	12	11	10	9	8	7	6	5	4	3	2	1	0
0	0	0	0	0	0	0	0	0	0	0	0	0	0	0	0
Hex Digit 4				Hex Digit 3			Hex Digit 2				Hex Digit 1				

Module Error Field

The purpose of the module error field is to classify module errors into three distinct groups, as described in the table below. The type of error determines what kind of information exists in the extended error information field. These types of module errors are typically reported in the controller's I/O status file. See the *MicroLogix 1400 Programmable Controllers Instruction Set Reference Manual*, publication [1766-RM001](#) for more information.

Module Error Types

Error Type	Module Error Field Value Bits 11 through 09 (Binary)	Description
No Errors	000	No error is present. The extended error field holds no additional information.
Hardware Errors	001	General and specific hardware error codes are specified in the extended error information field.
Configuration Errors	010	Module-specific error codes are indicated in the extended error field. These error codes correspond to options that you can change directly. For example, the input range or input filter selection.

Extended Error Information Field

Check the extended error information field when a non-zero value is present in the module error field. See *Extended Error Codes for 1762-IF2OF2* on page 214.

TIP If no errors are present in the module error field, the extended error information field is set to zero.

Hardware Errors

General or module-specific hardware errors are indicated by module error code 2.

Configuration Errors

If you set the fields in the configuration file to invalid or unsupported values, the module ignores the invalid configuration, generates a non-critical error, and keeps operating with the previous configuration.

The table below lists the configuration error codes defined for the module.

Error Codes

Extended Error Codes for 1762-IF2OF2

Error Type	Hex Equivalent ⁽¹⁾	Module Error Code	Extended Error Information Code	Error Description
		Binary	Binary	
No Error	X000	000	0 0000 0000	No error
General Common Hardware Error	X200	001	0 0000 0000	General hardware error; no additional information
	X201	001	0 0000 0001	Power-up reset state

Extended Error Codes for 1762-IF20F2

Error Type	Hex Equivalent ⁽¹⁾	Module Error Code	Extended Error Information Code	Error Description
		Binary	Binary	
Hardware-Specific Error	X210	001	0 0001 0000	Reserved
Configuration Error	X400	010	0 0000 0000	General configuration error; no additional information
	X401	010	0 0000 0001	Invalid input data format selected (channel 0)
	X402	010	0 0000 0010	Invalid input data format selected (channel 1)
	X403	010	0 0000 0011	Invalid output data format selected (channel 0)
	X404	010	0 0000 0100	Invalid output data format selected (channel 1)

⁽¹⁾ X represents "Don't Care".

Extended Error Codes for 1762-IF4 and 1762-OF4

Error Type	Hex Equivalent ⁽¹⁾	Module Error Code	Extended Error Information Code	Error Description
		Binary	Binary	
No Error	X000	000	0 0000 0000	No error
General Common Hardware Error	X200	001	0 0000 0000	General hardware error; no additional information
	X201	001	0 0000 0001	Power-up reset state
Hardware-Specific Error	X300	001	1 0000 0000	Reserved
Configuration Error	X400	010	0 0000 0000	General configuration error; no additional information
	X401	010	0 0000 0001	Invalid range select (Channel 0)
	X402	010	0 0000 0010	Invalid range select (Channel 1)
	X403	010	0 0000 0011	Invalid range select (Channel 2)
	X404	010	0 0000 0100	Invalid range select (Channel 3)
	X405	010	0 0000 0101	Invalid filter select (Channel 0) – 1762-IF4 only
	X406	010	0 0000 0110	Invalid filter select (Channel 1) – 1762-IF4 only
	X407	010	0 0000 0111	Invalid filter select (Channel 2) – 1762-IF4 only
	X408	010	0 0000 1000	Invalid filter select (Channel 3) – 1762-IF4 only
	X409	010	0 0000 1001	Invalid format select (Channel 0)
	X40A	010	0 0000 1010	Invalid format select (Channel 1)
	X40B	010	0 0000 1011	Invalid format select (Channel 2)
	X40C	010	0 0000 1400	Invalid format select (Channel 3)

⁽¹⁾ X represents "Don't Care".

Calling Rockwell Automation for Assistance

If you need to contact Rockwell Automation or local distributor for assistance, it is helpful to obtain the following (prior to calling):

- controller type, series letter, revision letter, and firmware (FRN) number of the controller
- controller indicator status

- controller error codes (Refer to MicroLogix 1400 Programmable Controllers Instruction Set Reference Manual, Publication [1766-RM001](#) for error code information.)

Using ControlFLASH to Upgrade Your Operating System

The operating system (OS) firmware can be upgraded through the Ethernet port of the controller. In order to download a new operating system, you must have the ControlFLASH™ Upgrade Kit referred to in the [ControlFLASH Upgrade Kit User Manual](#) as newer controller's operating system (OS) firmware is prepared in DMK format and requires ControlFLASH version 13.00 or higher.

Preparing for Firmware Upgrade

Before upgrading the controller's OS, you must:

- Install ControlFLASH software on your personal computer.
- Extract the DMK kit containing the latest Firmware – for ControlFLASH version 13.00 or higher only.
- Prepare the controller for updating.

Install ControlFLASH Software

To properly install ControlFLASH, refer to the Install ControlFLASH section in the [ControlFLASH Upgrade Kit User Manual](#).

If a ControlFLASH directory does not already exist, one is created in your Program Files directory.

Use DMK Extraction Tool for Firmware Upgrade

This section applies only to newer OS firmware prepared in DMK format, which requires ControlFLASH version 13.00 or higher.

1. Launch the DMK Extraction Tool application under Programs>Flash Programming Tools.

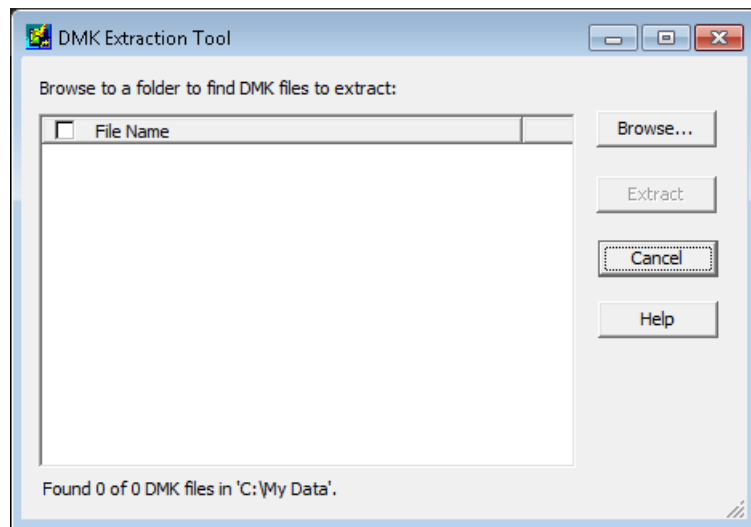

2. Click the Browse button and choose the location of DMK file in the system.

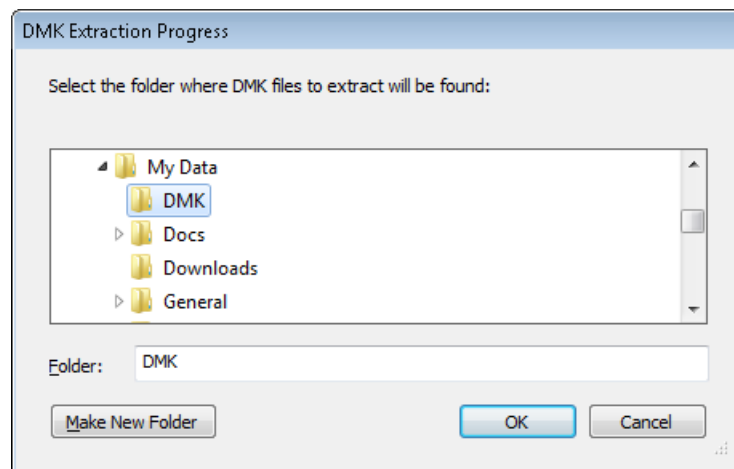

3. Click the OK button.

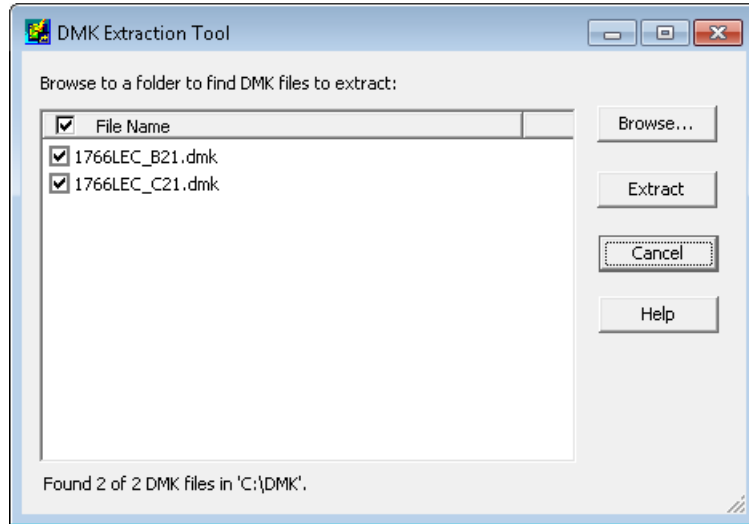

4. Select one or more DMK files that you want extract and click the Extract button.

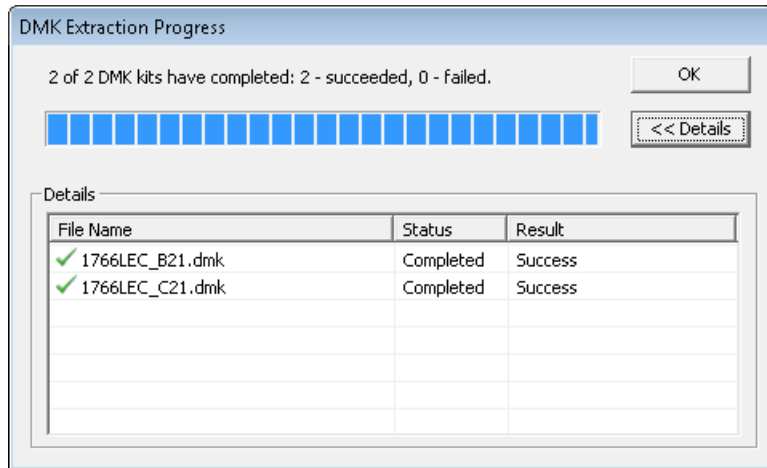

Click the OK button. Click the Cancel button to close the DMK Extraction Tool.

5. Once you have extracted the DMK files they will no longer appear in the Extraction Tool folder.

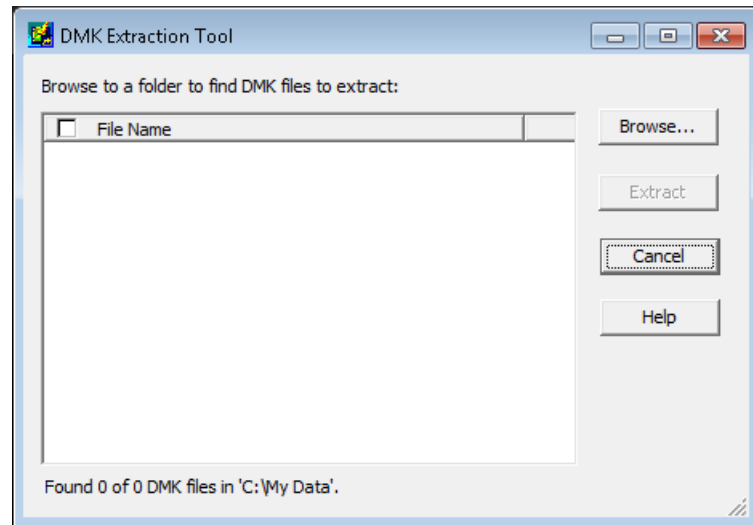

Prepare the Controller for Firmware Upgrade

1. It is important that the SNMP server is enabled before the firmware upgrade begins. You can check if the SNMP server is enabled by looking at the Channel Configuration page for Channel 1 in RSLogix 500/RSLogix Micro. If the SNMP server is not enabled, you can still enable it in the channel configuration page.

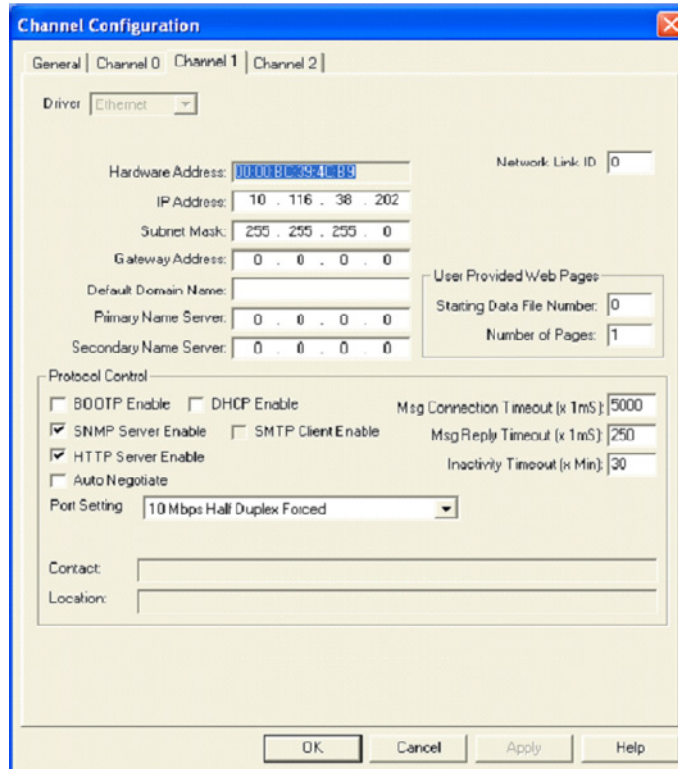

Alternatively, you can enable SNMP using the LCD display. For more information, [See Configuring Ethernet Protocol Setup on page 5-145](#)

IMPORTANT

The user program is cleared as part of the operating system upgrade process. You must restore your program after successfully loading the operating system upgrade. The Ethernet communication configuration parameters are retained after a successful firmware upgrade.

IMPORTANT

A power cycle is needed in order for the changes in the Channel Configuration page to be applied.

2. Ensure that you complete the IP configuration for the OS firmware upgrade. Note the assigned IP address of the controller.
If the IP address is not configured you can still perform the IP configuration using Static, BOOTP or DHCP settings. Once the IP configuration is done, it is used throughout the firmware upgrade process. If the IP configuration has been done, the IP address may be read from the processor when online with RSLogix 500/RSLogix Micro. In the Channel Configuration dialog box select the Chan. 1 - System tab or use the LCD.
3. The controller should be in Program mode before you start the firmware upgrade (access the Mode Switch from the LCD).

See [Using the Mode Switch on page 128](#) for information about controller modes and how to use the Mode Switch.

See [Viewing Ethernet Status on page 136](#) to find how to browse for the controller's IP address.

Using ControlFLASH for Firmware Upgrade



ATTENTION: Do not interrupt the flash procedure once you have begun to download the firmware. If the flash procedure is interrupted, the controller will be in a Missing or Corrupt OS state on the next power up.

To recover the controller from a missing/corrupt OS state, see [Missing or Corrupt OS state on page 234](#).

1. Launch the ControlFLASH application under Programs>Flash Programming Tools.
If the Ethernet connection (IP configuration) has not been established, attach an Ethernet cable to the controller from your computer (or a hub), and ensure that the Ethernet connection is intact throughout the upgrade process.

IMPORTANT

If you are connecting to the controller through a hub, you can use a standard Ethernet patch cable.
If you are connecting to the controller directly from your computer, you need to use an Ethernet crossover cable.

The Welcome to ControlFLASH dialog box is displayed.

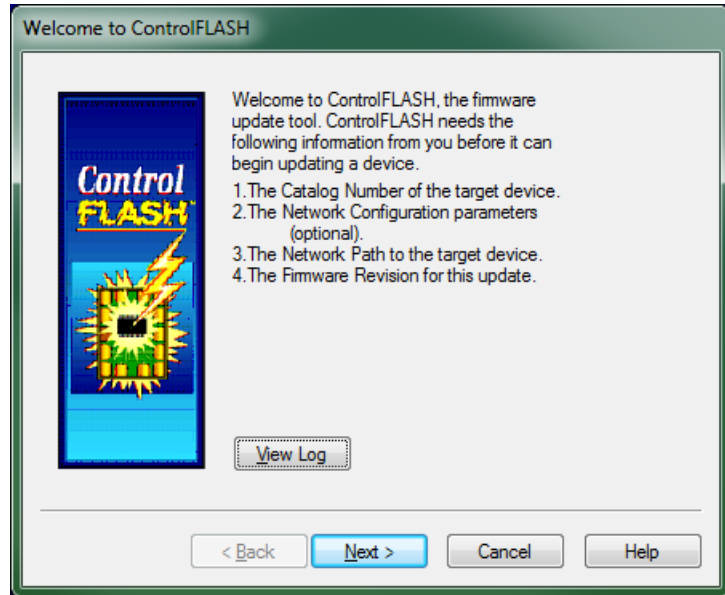

2. Click the Next button.
3. Select the appropriate catalog number from the Catalog Number dialog box and click the Next button.

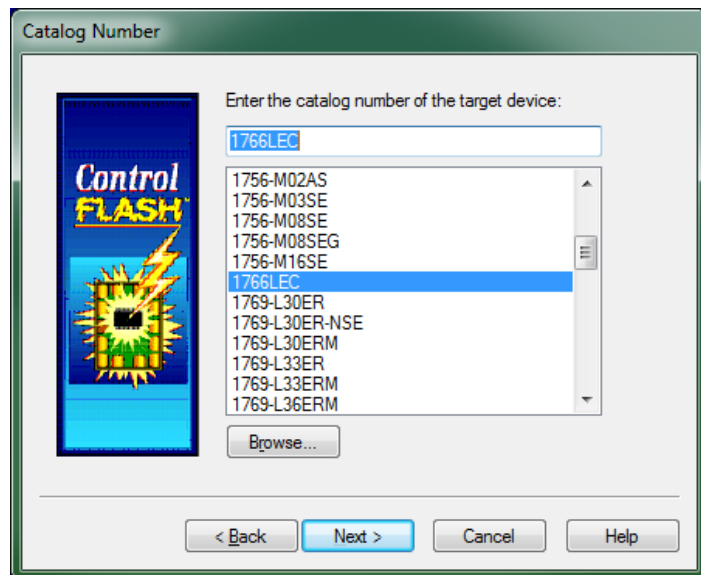

The AB_SNMP.DLL - Enter IP Address dialog box is displayed.

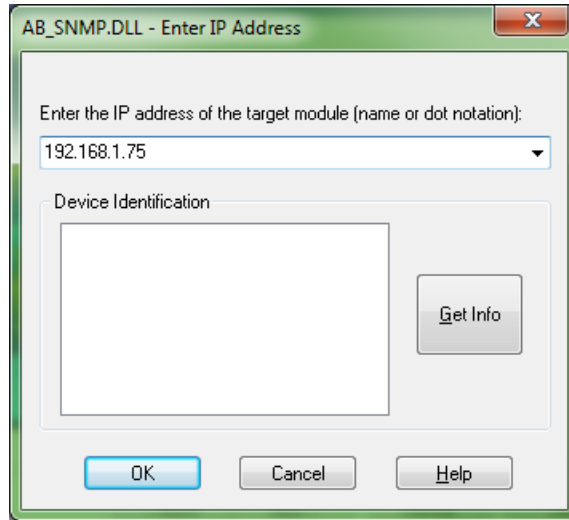

4. Type in the IP address for the processor.

IMPORTANT Use the IP address that was configured earlier, or use an available IP address assigned to by your network administrator.

5. Click the Get Info button. If the IP address was previously configured and the necessary information about the controller is obtained, go to step 9.
6. The AB_SNMP - BOOTP Server dialog box is displayed, indicating that this IP address has not been configured into the processor.

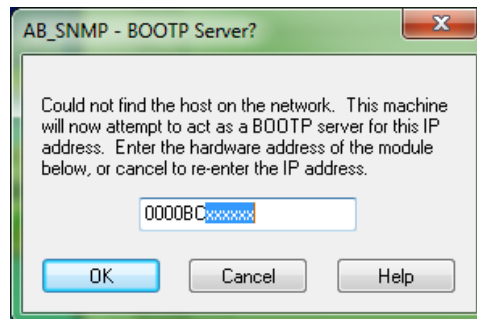

7. Enter the hardware address of the controller that is being upgraded (as noted in step 2 of [Prepare the Controller for Firmware Upgrade on page 221](#)) and click the OK button.

For the IP address to be configured using the ControlFLASH BOOTP server, the BOOTP settings should be enabled in the controller, see step 2 of [Prepare the Controller for Firmware Upgrade on page 221](#).

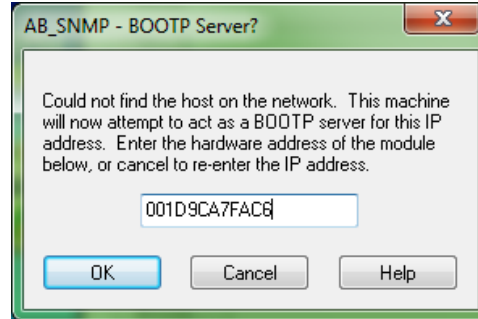

8. The AB_SNMP - BOOTP Server Running dialog box may take several seconds or minutes to appear.

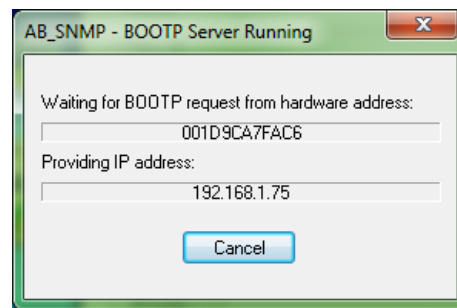

You may need to wait several seconds before you are returned to the AB_SNMP.DLL - Enter IP Address dialog box. Within several seconds, the Device Identification box displays the processor's current revision information.

9. Click the OK button.

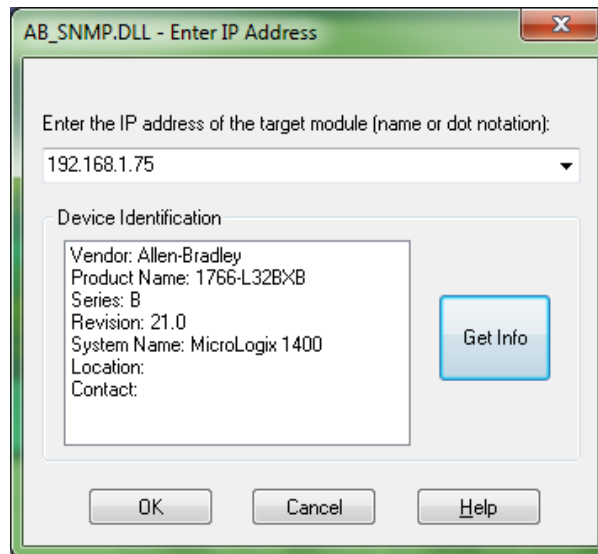

10. Select the appropriate firmware revision according to the controller series that is to be upgraded from the dialog box and click the Next button.

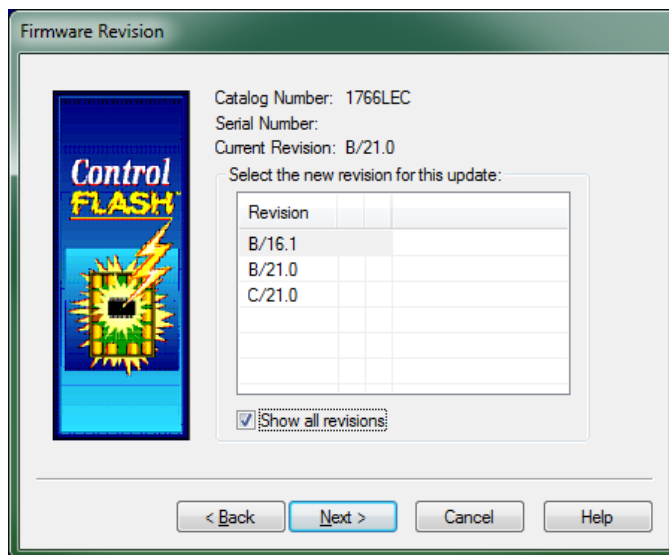

The Summary dialog box displays.

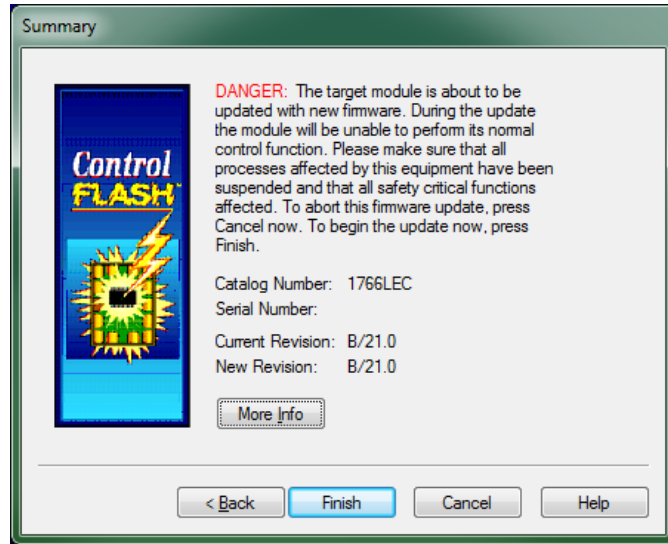

11. Click the Finish button.

The ControlFLASH dialog box displays.

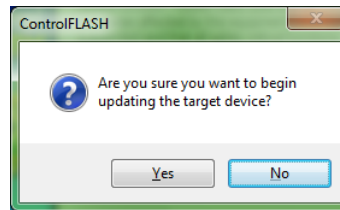

12. Click the Yes button if the firmware revision matches the controller series.
13. The following ControlFLASH warning displays for MicroLogix 1400 Series B controllers only.

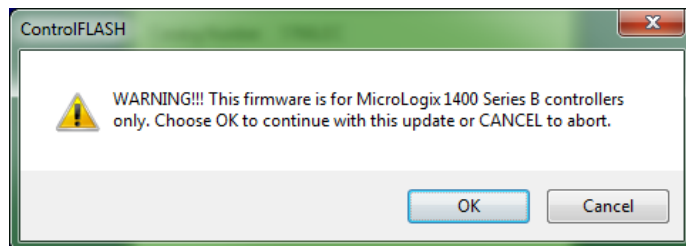

The following ControlFLASH warning displays for MicroLogix 1400 Series C controllers only.

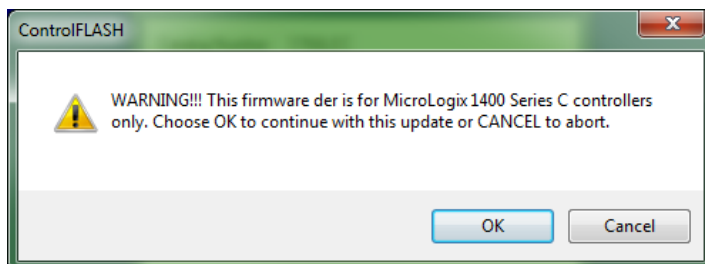

If your computer has more than one Ethernet interface installed, the following dialog box displays the assigned IP addresses of each of the listed Ethernet interfaces. Otherwise, go to step 17.

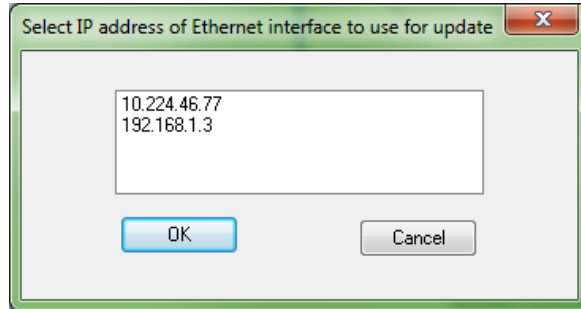

14. Highlight the IP address of the PC Ethernet interface that connects to the Ethernet network hosting the target processor, and click the OK button.
15. You may need to wait several seconds before the Progress dialog box is displayed. (A typical sequence is shown below). While the download is in progress, the RUN LED, FAULT LED and FORCE LED display a Walking Pattern (First RUN LED ON, then FAULT LED ON and then FORCE LED ON in sequence). When the flashing starts the POWER LED and the FORCE LED stay solid ON.

The concurrent ControlFLASH and LCD displays during the Firmware download are shown here.

Stage 1

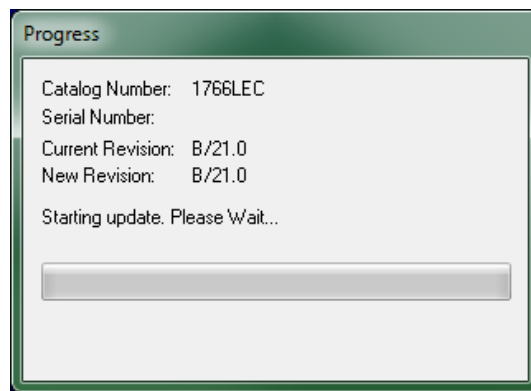

The LCD displays this screen:

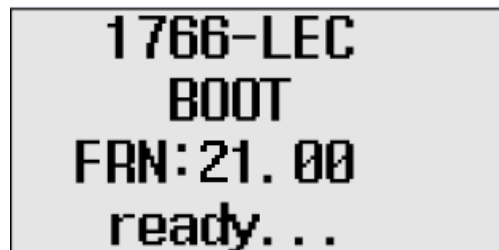

Stage 2

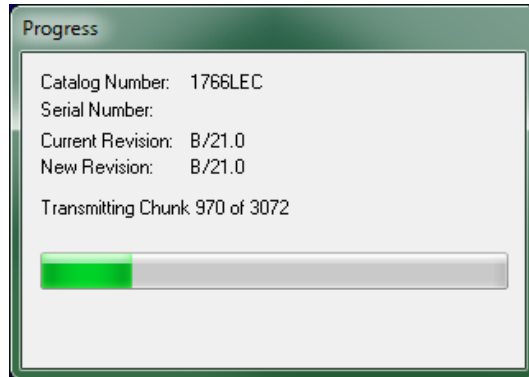

The LCD displays this screen:

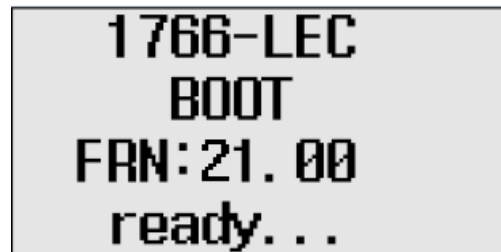

The Run, Fault and Force LEDs display a walking Pattern.

Stage 3 The LCD displays this screen:

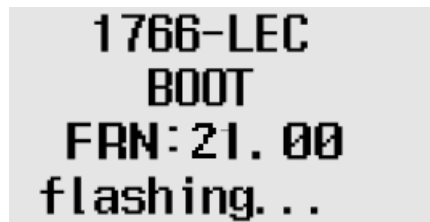
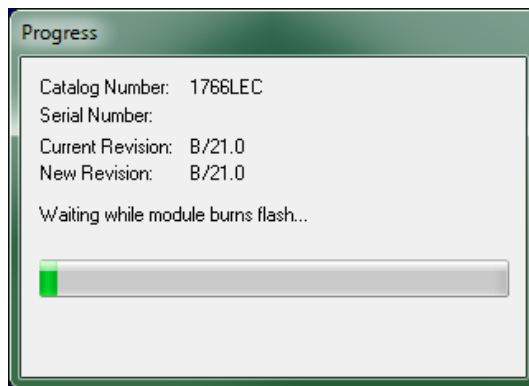

At this stage the Power and Force LEDs are solid ON.
After flashing of the controller, the LCD shows this screen:

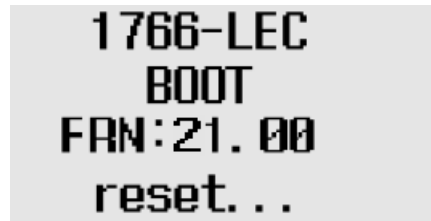

16. After the flashing is complete, the following dialog box prompts you to wait for the controller to reset, verify that the POWER LED is solid GREEN and verify the FAULT LED is turned OFF.

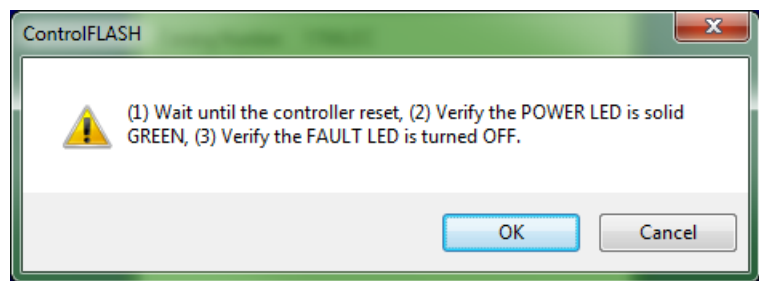

17. Click the OK button.
18. Enter the hardware address if prompted. Otherwise, the AB_SNMP - BOOTP Server Running dialog box may appear.

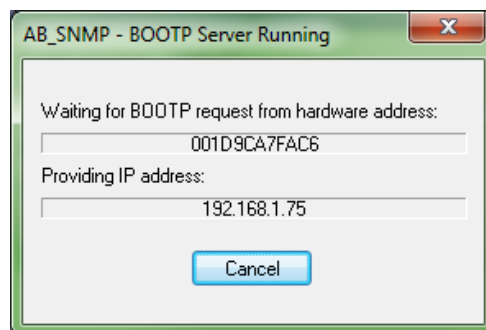
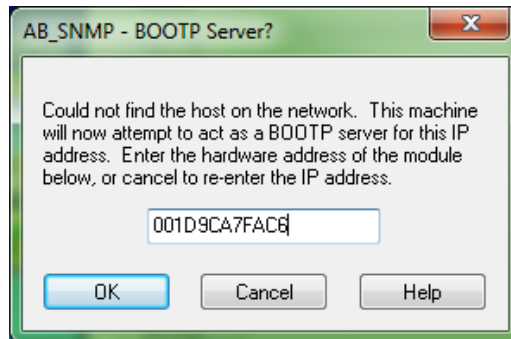

If the AB_SNMP - BOOTP Server Running dialog box appears and if there is no response from the controller for more than 30 seconds, click Cancel.

The Update Status dialog box is displayed. If the update was successful, the status text box is green and has an appropriate message.

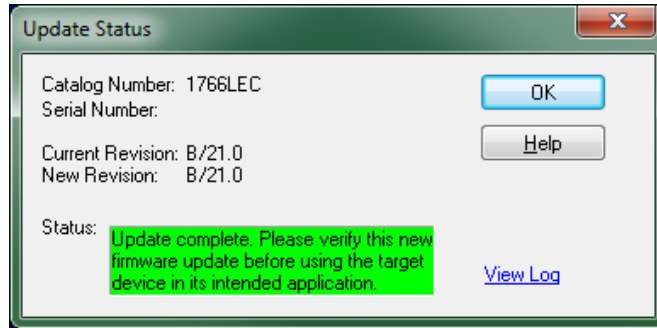

If the update was not successful, the status text box is red and has an appropriate message.

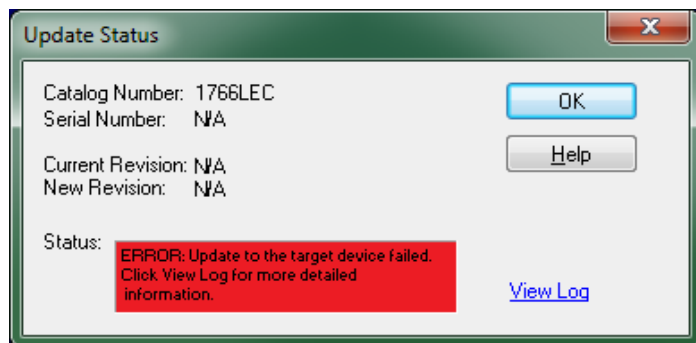

If the following dialog box appears, it indicates that the controller ended up in a Missing/Corrupt OS state. The current revision number reflects the version of Boot Firmware.

To recover the controller from this state, see [Recovering from Missing or Corrupt OS State on page 235](#).

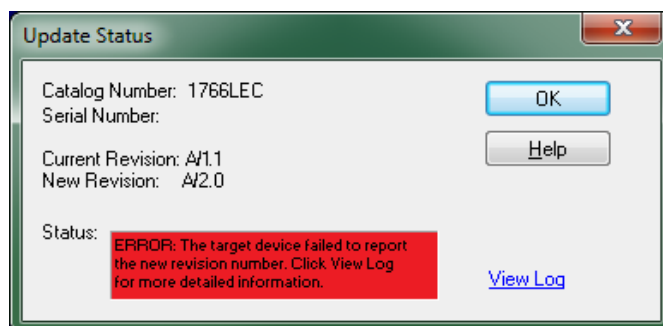

19. Click the OK button. You are returned to the Welcome to ControlFLASH dialog box.



20. You can continue to upgrade additional controllers by clicking the Next button, or exit the program by clicking the Cancel button.

If you click cancel, you are asked to verify that you want to end the update session.

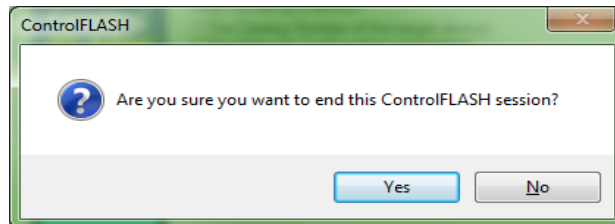

ControlFLASH Error Messages

The following are error messages you can receive.

- Invalid Catalog Number
- Target Module Not in Proper State for Programming
- Failed to Receive Initial TFTP Request from Target
- Communication error during TFTP transfer

Invalid Catalog Number



This error message is displayed if the ControlFLASH tool is unable to match the processor to the catalog number that was selected in the Catalog Number dialog box.

To clear this error:

1. Click the OK button to go to the Catalog Number dialog box.
2. Select the correct catalog number in the dialog box, and proceed with the update.
3. Restart the firmware upgrade procedure as described in the section [Using ControlFLASH for Firmware Upgrade on page 222](#).

Target Module Not in Proper State for Programming

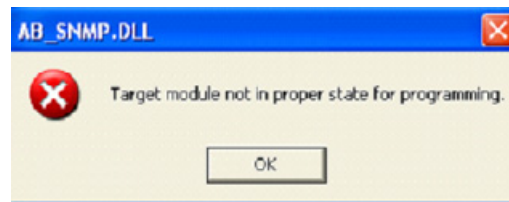

This error message is displayed when the target module is not in a proper state for programming.

To clear this error:

1. Put the controller in the PROGRAM mode.
2. Restart the firmware upgrade procedure as described in the section [Using ControlFLASH for Firmware Upgrade on page 222](#). If the error occurs again, cycle power and restart the firmware upgrade process.

Failed to Receive Initial TFTP Request from Target

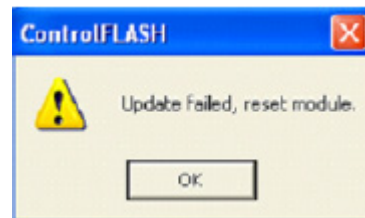
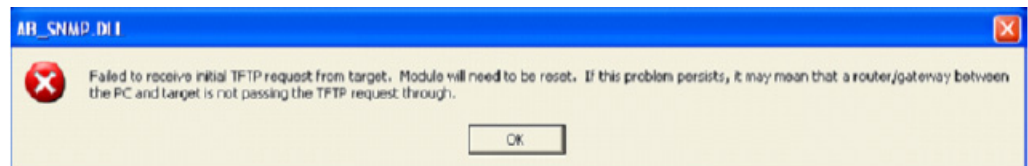

This error message is displayed when the initial TFTP request is not received.

To clear this error:

1. Connect the controller's Ethernet port directly to the computer's Ethernet port using a crossover cable, or disable or uninstall any firewall VPN or virus protection software running on the computer.
2. Cycle power to the processor.
3. Restart the firmware upgrade procedure as described in the section [Using ControlFLASH for Firmware Upgrade on page 222](#).

Communication error during TFTP transfer



This error message is displayed when there is a communication error during TFTP transfer.

To clear this error:

1. Check your Ethernet connections are intact.
2. Cycle power to the processor.
3. Restart the firmware upgrade procedure as described in the section [Using ControlFLASH for Firmware Upgrade on page 222](#)
4. If the error still persists, connect the controller's Ethernet port directly to the computer's Ethernet port using a crossover cable, and then repeat from step 2.

Missing or Corrupt OS state

The Boot Firmware runs the controller in this state.



ATTENTION: Do not interrupt the flash procedure, once you have begun to download the firmware. If the flash procedure is interrupted the controller will be in a Missing or Corrupt OS state on the next power up.

When the controller is in this state, the controller shows either one of the following:

- The POWER LED is solid ON and the RUN, FAULT and FORCE LEDs are blinking simultaneously. The LCD shows this information:

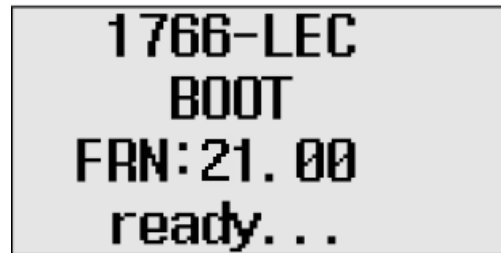

```
1766-LEC
BOOT
FRN:21.00
ready...
```

- The POWER and FAULT LED are solid ON and the LCD shows this information:

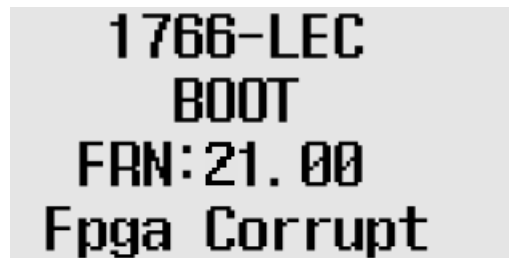

```
1766-LEC
BOOT
FRN:21.00
Fpga Corrupt
```

When the LCD displays the Fpga Corrupt information, the LEDs do not show the Walking pattern during the firmware upgrade process.

Recovering from Missing or Corrupt OS State

In order to recover from this controller state, you need to restart the operating system firmware upgrade as described here:

1. Ensure that the Ethernet connections are intact. SNMP is enabled by default in the controller.
2. If the IP Address was configured during the Preparing for firmware upgrade stage, the same IP configuration is retained in the controller.
3. Start the Firmware upgrade as explained in [Using ControlFLASH for Firmware Upgrade on page 222](#).

Notes:

Connecting to Networks via RS-232/RS-485 Interface

The following protocols are supported from the RS-232/485 combo communication channel (Channel 0) and the RS-232 communication channel (Channel 2):

- DF1 Full Duplex
- DF1 Half-Duplex Master/Slave
- DF1 Radio Modem
- DH-485
- Modbus RTU Master/Slave
- ASCII
- DNP3 Slave

RS-232 Communication Interface

The communications port on Channel 0 of the MicroLogix 1400 controller utilizes a combined, isolated RS-232/485 interface. RS-232 and RS-485 are Electronics Industries Association (EIA) standards that specify the electrical and mechanical characteristics for serial binary communication. They provide a variety of system configuration possibilities (RS-232 and RS-485 define electrical connection characteristics, *not* protocols).

The MicroLogix 1400 controller supports an additional, non-isolated RS-232 interface on Channel 2. One of the biggest benefits of an RS-232 interface is that it lets you integrate telephone and radio modems into your control system (using the appropriate DF1 protocol only, not DH-485 protocol), but it is for point-to-point connections only between two devices.

RS-485 Communication Interface

The RS-485 interface supports connection of devices in a multidrop hard-wired configuration using DH-485, DF1-Half Duplex, Modbus, or DNP3 protocols. Also, the RS-485 interface supports connection in a multidrop hard-wired configuration using ASCII protocols.

DF1 Full-Duplex Protocol

DF1 Full-Duplex protocol provides a point-to-point connection between two devices. DF1 Full-Duplex protocol combines data transparency (American National Standards Institute ANSI - X3.28-1976 specification subcategory D1) and 2-way simultaneous transmission with embedded responses (subcategory F1).

The MicroLogix controller supports the DF1 Full-Duplex protocol via RS-232 connection to external devices, such as computers, or other controllers that support DF1 Full-Duplex.

DF1 is an open protocol. Refer to DF1 Protocol and Command Set Reference Manual, publication 1770-6.5.16, for more information.

DF1 Full-Duplex protocol (also referred to as DF1 point-to-point protocol) is useful where RS-232 point-to-point communication is required. DF1 protocol controls message flow, detects and signals errors, and retries if errors are detected.

Example DF1 Full-Duplex Connections

For information about required network connecting equipment, see Chapter 4, Communication Connections.

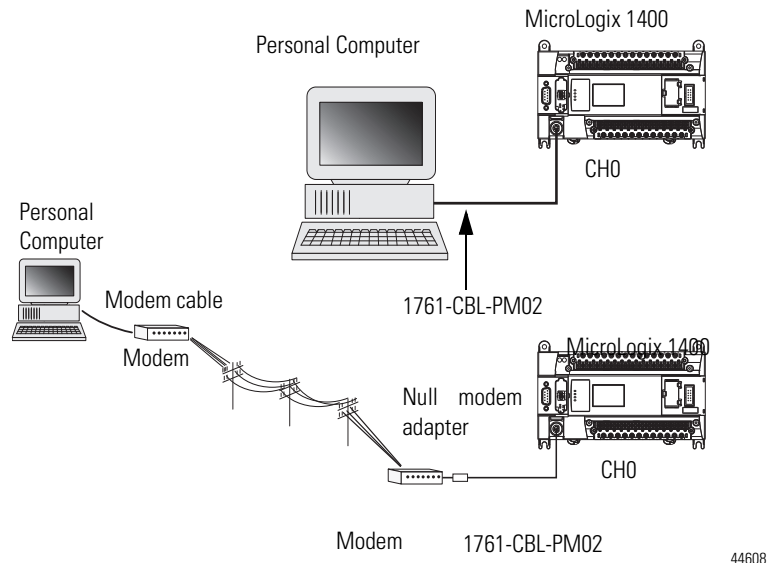

DF1 Half-Duplex Protocol

DF1 Half-Duplex protocol is a multi-drop single master/multiple slave network. DF1 Half-Duplex protocol supports data transparency (American National Standards Institute ANSI - X3.28-1976 specification subcategory D1). In contrast to DF1 Full-Duplex, communication takes place in one direction at a time. You can use the RS-232/485 port on the MicroLogix as both a Half-Duplex programming port and a Half-Duplex peer-to-peer messaging port.

DF1 Half-Duplex Operation

A DF1 Half-Duplex master device initiates all communication by “polling” each slave device. The slave device may only transmit when it is polled by the master. It

is the master's responsibility to poll each slave on a regular and sequential basis to allow slave devices an opportunity to communicate.

An additional feature of the DF1 Half-Duplex protocol is that it is possible for a slave device to enable a MSG write or read to/from another slave. When the initiating slave is polled, the MSG is sent to the master. The master recognizes that the message is not intended for it, but for another slave, so the master immediately forwards the message to the intended slave. The master does this automatically; you do not need to program the master to move data between slave nodes. This slave-to-slave transfer can also be used by programming software to allow slave-to-slave upload and download of programs to processors (including the master) on the DF1 Half-Duplex link.

MicroLogix 1400 can act as the master or as a slave on a Half-Duplex network. When the MicroLogix 1400 is a slave device, a master device is required to "run" the network. Several other Allen-Bradley products support DF1 Half-Duplex master protocol. They include the SLC™ 5/03 and higher processors, enhanced PLC-5 processors, MicroLogix 1200/1500, and Rockwell Software RSLinx (version 2.x and higher).

DF1 Half-Duplex supports up to 255 devices (address 0 to 254) with address 255 reserved for master broadcasts. As a DF1 Half-Duplex slave device, the MicroLogix supports broadcast reception. As a DF1 Half-Duplex master, the MicroLogix 1400 supports both the reception and initiation of broadcast write commands (via the MSG instruction). The MicroLogix also supports Half-Duplex modems using RTS/CTS hardware handshaking.

Example DF1 Half-Duplex Connections

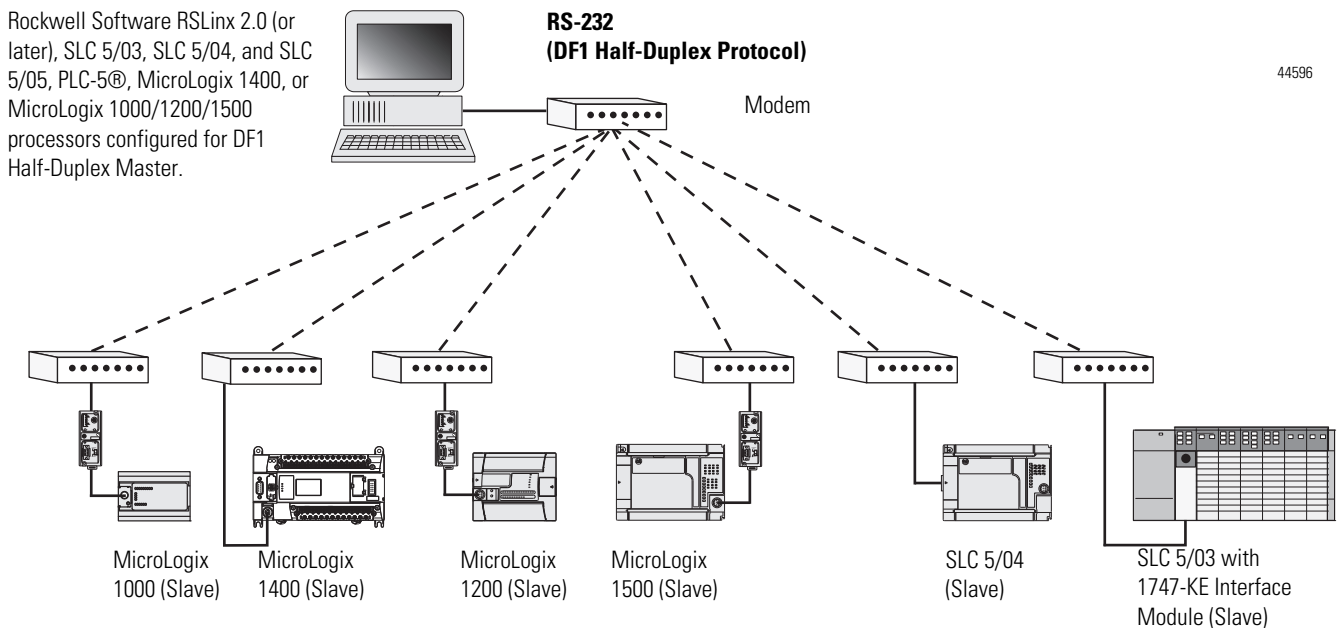

Considerations When Communicating as a DF1 Slave on a Multi-drop Link

When communication is between either your programming software and a MicroLogix Programmable Controller or between two MicroLogix 1400 Programmable Controllers via slave-to-slave communication on a larger multi-drop link, the devices depend on a DF1 Half-Duplex Master to give each of them access in a timely manner. As the number of slave devices increase, the time between when slave devices are polled also increases. This increase in time may also be large if you are using low baud rates. As these time periods grow, you may need to increase the poll timeout and reply timeout values for slave devices.

IMPORTANT If a program download is started when using DF1 Half-Duplex, but then is interrupted due to electromagnetic interference or other events, discontinue communications to the controller for the *ownership timeout* period and then restart the program download. The *ownership timeout* period is 60 seconds. After the timeout, you can re-establish communications with the processor and try the program download again. The only other way to remove program ownership is to cycle power on the processor.

Using Modems with MicroLogix Programmable Controllers

The types of modems you can use with MicroLogix controllers include the following:

- dial-up phone modems.
A MicroLogix controller, on the receiving end of the dial-up connection, can be configured for DF1 Full-Duplex protocol with or without handshaking. The modem connected to the MicroLogix controller should support auto-answer. The MicroLogix 1400 supports ASCII out communications. Therefore, it can cause a modem to initiate or disconnect a phone call.
- leased-line modems.
Leased-line modems are used with dedicated phone lines that are typically leased from the local phone company. The dedicated lines may be in a point-to-point topology supporting Full-Duplex communications between two modems or in a multi-drop topology supporting Half-Duplex communications between three or more modems.
- radio modems.
Radio modems may be implemented in a point-to-point topology supporting either Half-Duplex or Full-Duplex communications, or in a multi-drop topology supporting Half-Duplex communications between three or more modems. MicroLogix 1400 also supports DF1 Radio Modem protocol.

- line drivers.
Line drivers, also called short-haul modems, do not actually modulate the serial data, but rather condition the electrical signals to operate reliably over long transmission distances (up to several miles). Line drivers are available in Full-Duplex and Half-Duplex models. Allen-Bradley's AIC+ Advanced Interface Converter is a Half-Duplex line driver that converts an RS-232 electrical signal into an RS-485 electrical signal, increasing the signal transmission distance from 50 to 4000 feet (8000 feet when bridged).

For point-to-point Full-Duplex modem connections that do not require any modem handshaking signals to operate, use DF1 Full-Duplex protocol with no handshaking. For point-to-point Full-Duplex modem connections that require RTS/CTS handshaking, use DF1 Full-Duplex protocol with handshaking.

For radio modem connections, use DF1 Radio Modem protocol, especially if store and forward capability is required.

For general multi-drop modem connections, or for point-to-point modem connections that require RTS/CTS handshaking, use DF1 Half-Duplex slave protocol. In this case, one (and only one) of the other devices must be configured for DF1 Half-Duplex master protocol.

IMPORTANT Never attempt to use DH-485 protocol through modems under any circumstance.

TIP All MicroLogix controllers support RTS/CTS modem handshaking when configured for DF1 Full-Duplex protocol with the control line parameter set to Full-Duplex Modem Handshaking or DF1 Half-Duplex slave protocol with the control line parameter set to "Half-Duplex Modem".
MicroLogix 1400 controllers also support DCD (Data Carrier Detect) line for DF1 Radio Modem protocol. For other protocols, you can only access the DCD signal from your ladder logic. No other modem handshaking lines (such as Data-Set™ Ready and Data Terminal Ready) are supported by MicroLogix 1400 controller.

DH-485 Communication Protocol

The DH-485 protocol defines the communication between multiple devices that coexist on a single pair of wires. DH-485 protocol uses RS-485 Half-Duplex as its physical interface. (RS-485 is a definition of electrical characteristics; it is *not* a protocol.) RS-485 uses devices that are capable of co-existing on a common data circuit, thus allowing data to be easily shared between devices.

The DH-485 network offers:

- interconnection of 32 devices
- multi-master (peer-to-peer) capability
- token passing access control
- the ability to add or remove nodes without disrupting the network

- maximum network segment of 1,219 m (4,000 ft.)

The DH-485 protocol supports two classes of devices: initiators and responders. All initiators on the network get a chance to initiate message transfers. To determine which initiator has the right to transmit, a token passing algorithm is used.

Control of message transfers on the DH-485 network is performed by rotating the token along the nodes on the network. A node holding the token can send a message onto the network. Each node is allowed a fixed number of transmissions (based on the Token Hold Factor) each time it receives the token. After a node sends a message, it passes the token to the next device.

The allowable range of node addresses is 1...31. There must be at least one initiator on the network (such as a MicroLogix controller, or an SLC 5/02 or later processor).

DH-485 Configuration Parameters

When MicroLogix communications are configured for DH-485, the following parameters can be changed:

DF1 Full-Duplex Configuration Parameters

Parameter	Options
Baud Rate	9600, 19.2K
Node Address	1...31 decimal
Token Hold Factor	1...4

See [Software Considerations on page 245](#) for tips on setting the parameters listed above.

Devices that use the DH-485 Network

In addition to the MicroLogix controllers, the devices shown in the following table also support the DH-485 network.

Devices that Support DH-45 Network

Catalog Number	Description	Installation	Function	Publication
Bulletin 1761 Controllers	MicroLogix 1000	Series C or later	These controllers support DH-485 communications.	1761-UM003
Bulletin 1762	MicroLogix 1200	Series A or later	These controllers support DH-485 communications.	1762-UM001
Bulletin 1763	MicroLogix 1100	Series A or later	These controllers support DH-485 communications.	1763-UM001
Bulletin 1764	MicroLogix 1500	Series A or later	These controllers support DH-485 communications.	1764-UM001
Bulletin 1747 Processors	SLC 500 Processors	SLC Chassis	These processors support a variety of I/O requirements and functionality.	1747-UM011

Devices that Support DH-45 Network

Catalog Number	Description	Installation	Function	Publication
1746-BAS	BASIC Module	SLC Chassis	Provides an interface for SLC 500 devices to foreign devices. Program in BASIC to interface the 3 channels (2 RS232 and 1 DH-485) to printers, modems, or the DH-485 network for data collection.	1746-UM004 1746-PM001 1746-RM001
2760-RB	Flexible Interface Module	(1771) PLC Chassis	Provides an interface for SLC 500 (using protocol cartridge 2760-SFC3) to other A-B PLCs and devices. Three configurable channels are available to interface with Bar Code, Vision, RF, DataLiner™, and PLC systems.	1747-6.12 2760-ND001
1784-PKTX, -PKTXD	PC DH-485 IM	PCI Computer Bus	Provides DH-485 using RSLinx.	1784-6.5.22
1784-PCMK	PCMCIA IM	PCMCIA slot in computer	Provides DH-485 using RSLinx.	1784-UM519
2711-K5A2, -B5A2, -K5A5, -B5A5, -K5A1, -B5A1, -K9A2, -T9A2, -K9A5, -T9A5, -K9A1, and -T9A1	PanelView 550 and PanelView 900 Operator Terminals	Panel Mount	Provides electronic operator interface for SLC 500 processors.	2711-UM014

Important DH-485 Network Planning Considerations

Carefully plan your network configuration before installing any hardware. Some of the factors that can affect system performance are:

- amount of electrical noise, temperature, and humidity in the network environment.
- number of devices on the network.
- connection and grounding quality in installation.
- amount of communication traffic on the network.
- type of process being controlled.
- network configuration.

The major hardware and software issues you need to resolve before installing a network are discussed in the following sections.

Hardware Considerations

You need to decide the length of the communication cable, where you route it, and how to protect it from the environment where it will be installed.

When the communication cable is installed, you need to know how many devices are to be connected during installation and how many devices will be added in the future. The following sections help you understand and plan the network.

Number of Devices and Length of Communication Cable

The maximum length of the communication cable is 1219 m (4000 ft). This is the total cable distance from the first node to the last node in a segment. However, two segments can be used to extend the DH-485 network to 2438 m

(8000 ft.). For additional information on connections using the AIC+, refer to the Advanced Interface Converter DeviceNet Interface User Manual, publication [1761-IN002](#).

Planning Cable Routes

Follow these guidelines to help protect the communication cable from electrical interference:

- Keep the communication cable at least 1.52 m (5 ft.) from any electric motors, transformers, rectifiers, generators, arc welders, induction furnaces, or sources of microwave radiation.
- If you must run the cable across power feed lines, run the cable at right angles to the lines.
- If you do not run the cable through a contiguous metallic wireway or conduit, keep the communication cable at least 0.15 m (6 in.) from AC power lines of less than 20 A, 0.30 m (1 ft.) from lines greater than 20 A, but only up to 100K VA, and 0.60 m (2 ft.) from lines of 100 K VA or more.
- If you run the cable through a contiguous metallic wireway or conduit, keep the communication cable at least 0.08 m (3 in.) from AC power lines of less than 20 A, 0.15 m (6 in.) from lines greater than 20 A, but only up to 100 K VA, and 0.30 m (1 ft.) from lines of 100 K VA or more.

Running the communication cable through conduit provides extra protection from physical damage and electrical interference. If you route the cable through conduit, follow these additional recommendations:

- Use ferromagnetic conduit near critical sources of electrical interference. You can use aluminum conduit in non-critical areas.
- Use plastic connectors to couple between aluminum and ferromagnetic conduit. Make an electrical connection around the plastic connector (use pipe clamps and the heavy gauge wire or wire braid) to hold both sections at the same potential.
- Ground the entire length of conduit by attaching it to the building earth ground.
- Do not let the conduit touch the plug on the cable.
- Arrange the cables loosely within the conduit. The conduit should contain only serial communication cables.
- Install the conduit so that it meets all applicable codes and environmental specifications.

For more information on planning cable routes, see *Industrial Automation Wiring and Grounding Guidelines*, publication [1770-4.1](#).

Software Considerations

Software considerations include the configuration of the network and the parameters that can be set to the specific requirements of the network. The following are major configuration factors that have a significant effect on network performance:

- number of nodes on the network
- addresses of those nodes
- baud rate

The following sections explain network considerations and describe ways to select parameters for optimum network performance (speed). See your programming software's user manual for more information.

Number of Nodes

The number of nodes on the network directly affects the data transfer time between nodes. Unnecessary nodes (such as a second programming terminal that is not being used) slow the data transfer rate. The maximum number of nodes on the network is 32.

Setting Node Addresses

The best network performance occurs when node addresses are assigned in sequential order. Initiators, such as personal computers, should be assigned the lowest numbered addresses to minimize the time required to initialize the network. The valid range for the MicroLogix controllers is 1...31 (controllers cannot be node 0). The default setting is 1. The node address is stored in the controller Communications Status file (CS0:5/0 to CS0:5/7).

Setting Controller Baud Rate

The best network performance occurs at the highest baud rate, which is 19,200. This is the default baud rate for a MicroLogix device on the DH-485 network. All devices must be at the same baud rate. This rate is stored in the controller Communications Status file (CS0:5/8 to CS0:5/15).

Setting Maximum Node Address

Once you have an established network set up and are confident that you will not be adding more devices, you may enhance performance by adjusting the maximum node address of your controllers. It should be set to the highest node address being used.

IMPORTANT All devices should be set to the same maximum node address.

MicroLogix Remote Packet Support

MicroLogix controllers can respond and initiate with communications (or commands) that do not originate on the local DH-485 network. This is useful in installations where communication is needed between DH-485 and Data Highway Plus (DH+™) networks.

The example below shows how to send messages from a device on the DH+ network to a MicroLogix controller on the DH-485 network. This method uses an SLC 5/04 processor as the bridge connection.

When using this method (as shown in the illustration below):

- PLC-5 devices can send read and write commands to MicroLogix controllers.
- MicroLogix controllers can respond to MSG instructions received.
- The MicroLogix controllers can initiate MSG instructions to devices on the DH+ network.
- PC can send read and write commands to MicroLogix controllers.
- PC can do remote programming of MicroLogix controllers.

TIP

Use a 1763-NC01 Series A or later cable to connect a MicroLogix 1400 controller to a DH-485 network.

You can connect a MicroLogix 1400 controller to your DH-485 network directly without using a RS-232 to RS-485 converter and optical isolator, such as the AIC+, catalog number 1761-NET-AIC, as shown in the illustration below, because Channel 0 has isolation and RS-485 built-in.

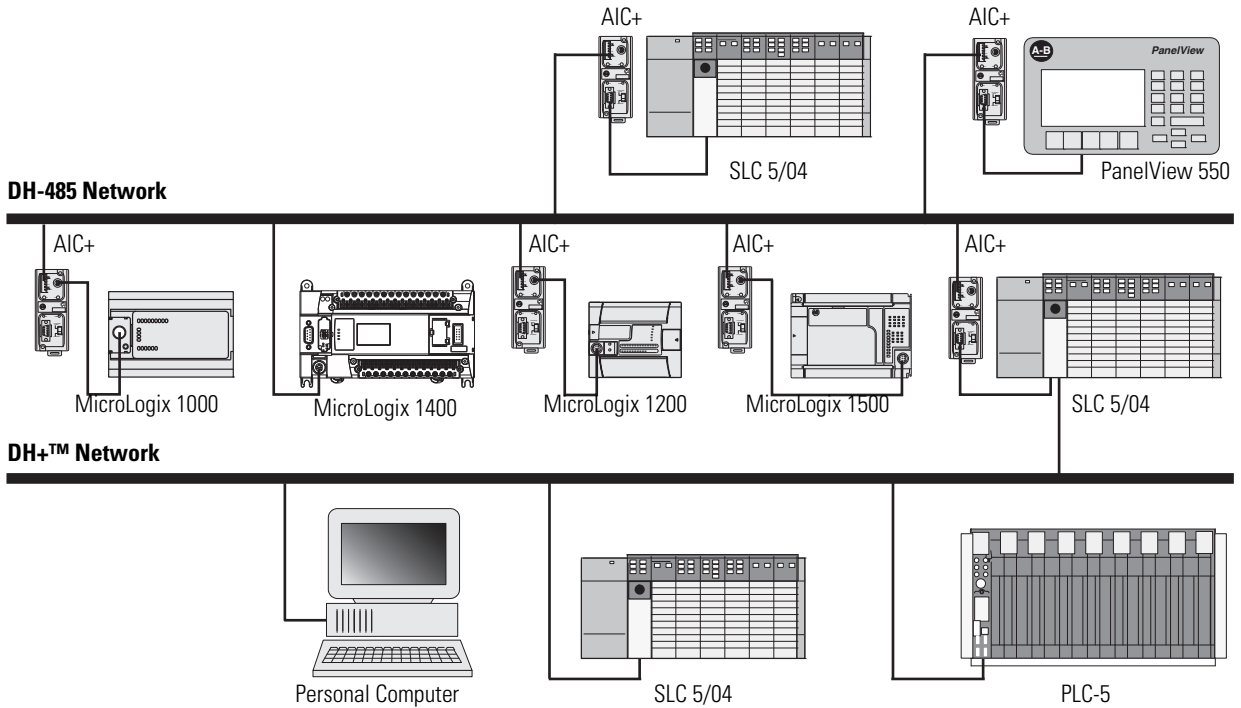

44609

Example DH-485 Connections

The following network diagrams provide examples of how to connect MicroLogix controllers to the DH-485 network. You can connect a MicroLogix 1400 controller to your DH-485 network directly without using a RS-232 to RS-485 converter and optical isolator, such as the Advanced Interface Converter (AIC+), catalog number 1761-NET-AIC, as shown in the illustrations below, because Channel 0 has isolation and RS-485 built-in.

However, you may need to use an AIC+ to connect Channel 2 of the MicroLogix 1400 controller to a DH-485 network. For more information on the AIC+, see the Advanced Interface Converter and DeviceNet Interface Installation Instructions, Publication [1761-IN002](#).

DH-485 Network with a MicroLogix Controller

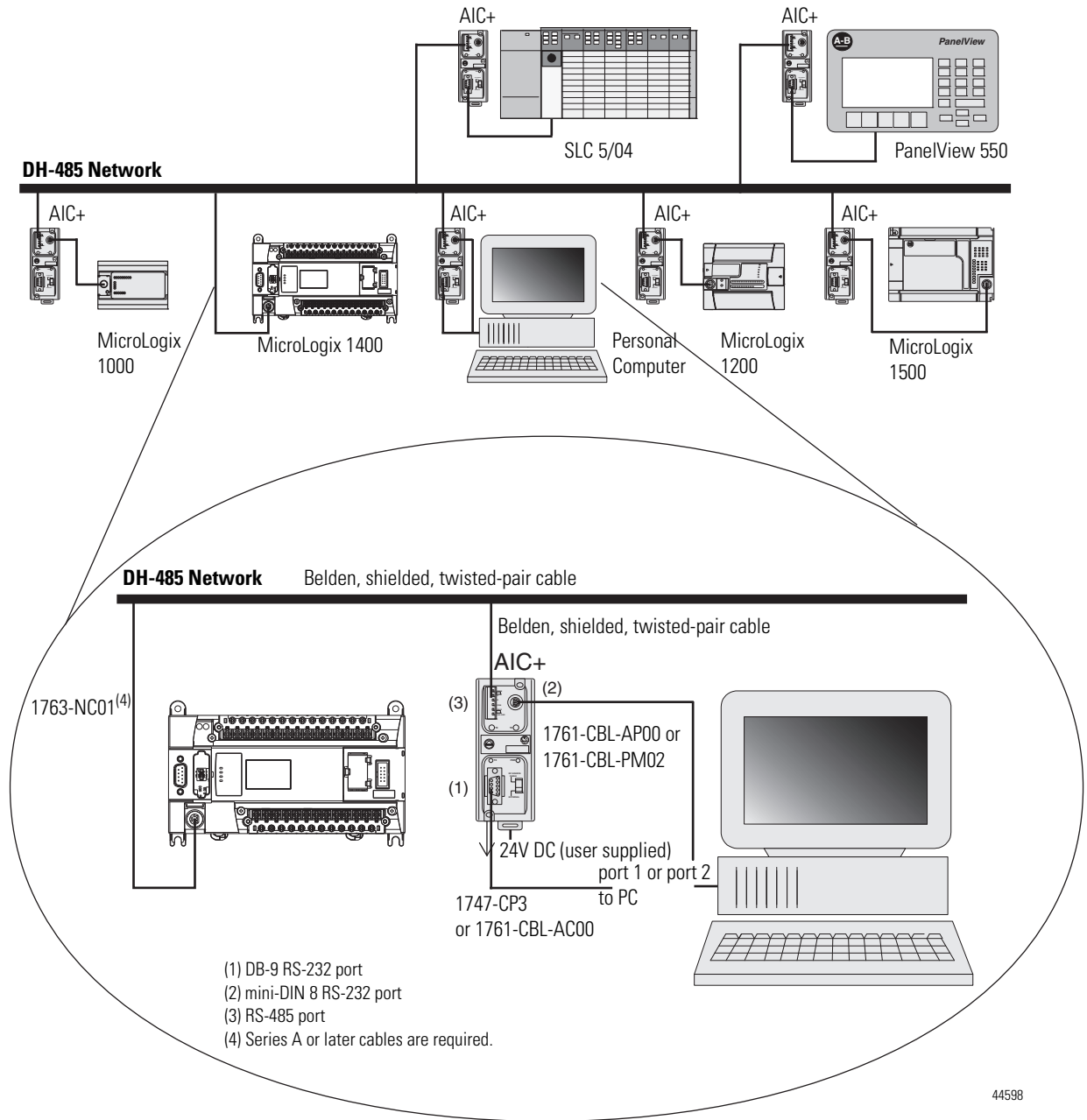

44598

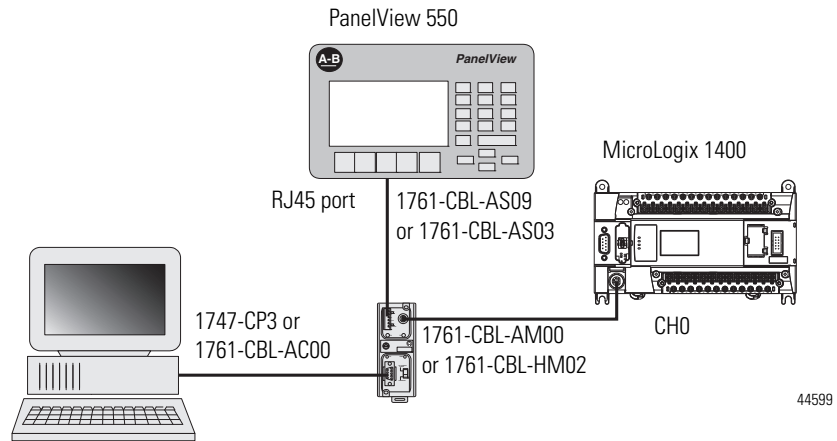
Typical 3-Node Network

TIP This 3-node network is not expandable.

Modbus Communication Protocol

Modbus is a Half-Duplex, master-slave communications protocol. The Modbus network master reads and writes coils and registers. Modbus protocol allows a single master to communicate with a maximum of 247 slave devices. MicroLogix 1400 controllers support Modbus RTU Master and Modbus RTU Slave protocol.

For more information on configuring your MicroLogix 1400 controller for Modbus protocol, refer to the MicroLogix 1400 Programmable Controllers Instruction Set Reference Manual, publication 1766-RM001. For more information about the Modbus protocol, see the Modbus Protocol Specifications (available from <http://www.modbus.org>).

ASCII

ASCII provides connection to other ASCII devices, such as bar code readers, weigh scales, serial printers, and other intelligent devices.

You can use ASCII by configuring the RS-232/485 port, channel 0 and the RS-232 port, Channel 2 for the ASCII driver. Refer to the MicroLogix 1400 Programmable Controllers Instruction Set Reference Manual, publication [1766-RM001](http://www.rockwellautomation.com/literature/1766-RM001) for detailed configuration information.

Distributed Network Protocol (DNP3)

For more information on configuring your MicroLogix 1400 controller for Distributed Network Protocol, see [Channel Configuration for DNP3 Slave on page 253](#). For more information about Distributed Network Protocol, see the Distributed Network Protocol Specifications, available from <http://www.dnp.org>.

Disable Serial Channels 0 and 2

In RSLogix 500 software, you can disable Serial Channels 0 and/or 2 to enhance security.

1. Open the Channel Configuration in the MicroLogix 1400 project tree and select a channel.

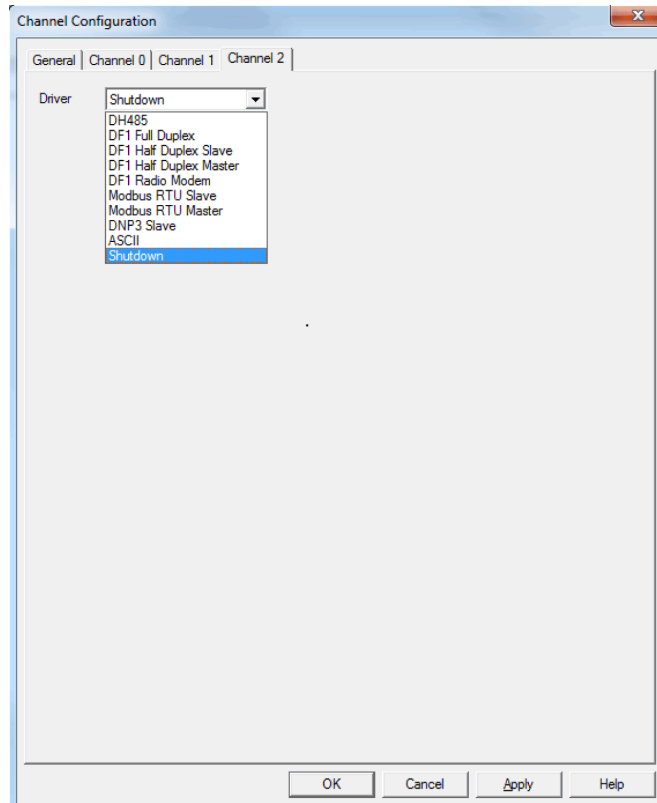

2. From the Driver drop-down list, select Shutdown.
3. Click Apply and OK.

The selected serial channels are disabled.

IMPORTANT

At least 1 of the 3 channels must be active to enable communication with the RSLogix 500 software. You cannot disable the last serial channel if the other 2 channels (Serial, Ethernet) are already configured as disabled.

Notes:

Notes:

MicroLogix 1400 Distributed Network Protocol (DNP3)

This appendix:

- describes the MicroLogix 1400 Distributed Network Protocol (DNP3).
- describes the procedures used to program and troubleshoot DNP3 protocol in the controller.
- gives an overview of the DNP3 implementation in the controller
- shows application examples of DNP3 applications.

Channel Configuration for DNP3 Slave

The default communication protocol for the serial ports Channel 0 and Channel 2 in the MicroLogix 1400 is DF1 Full-Duplex. To communicate with DNP3 protocol, the channel must be configured to DNP3 protocol.

The default communication protocol for the Ethernet Channel 1 in the MicroLogix 1400 is Ethernet/IP. To communicate with DNP3 over IP protocol in the MicroLogix 1400 Series B and Series C controller, the channel must be configured to use the DNP3 protocol.

The MicroLogix 1400 Series A controller supports DNP3 protocol via Channel 0 and/or Channel 2 Serial ports.

The MicroLogix 1400 Series B and Series C controller also supports DNP3 over IP protocol via Channel 1 Ethernet port.

To program the MicroLogix 1400 controller, use RSLogix 500/RSLogix Micro software, version 8.10.00 or later for Series A controller and version 8.30.00 or later for Series B and Series C controller, and version 11.

In RSLogix 500/RSLogix Micro, open Channel Configuration in the MicroLogix 1400 project tree.

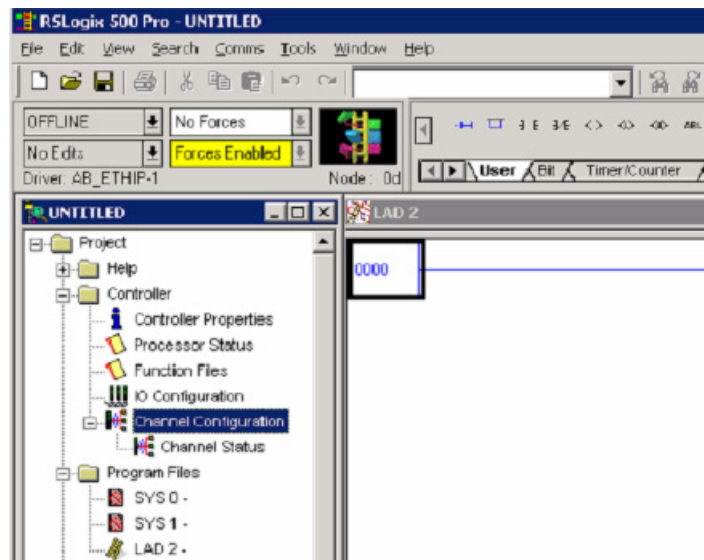

There are 4 configurations related to DNP3 protocol in RSLogix 500/RSLogix Micro software:

- Channel 0 configuration
- Channel 2 configuration
- Channel 1 configuration
- DNP3 Slave Application Layer configuration.

Channel 0 and Channel 2 Link Layer Configuration

Link Layer related configuration can be done in the Channel 0 and/or Channel 2 tab.

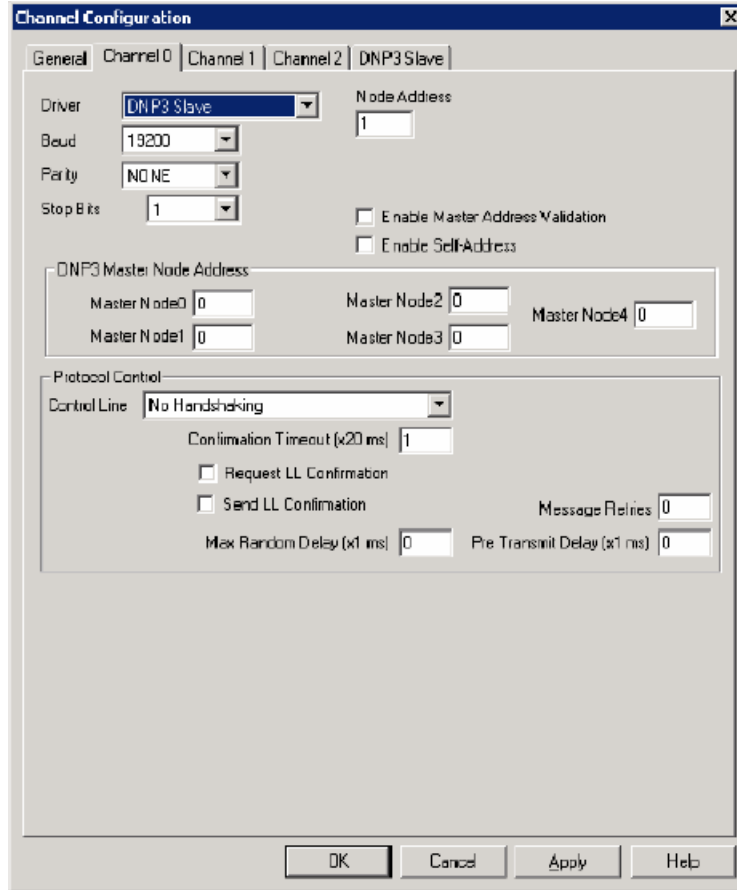

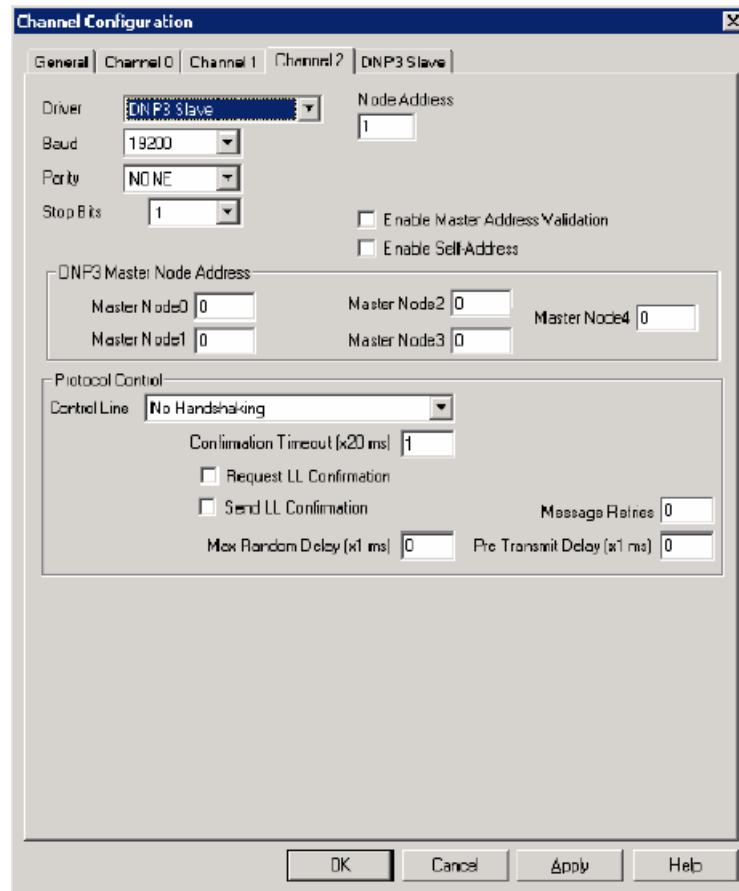

Channel 1 Link Layer Configuration

In RSLogix 500/RSLogix Micro, open Channel Configuration in the MicroLogix 1400 Series B and Series C project tree.

To enable DNP3 over IP protocol, check DNP3 over IP Enable in the Channel 1 configuration.

Unlike serial port configuration, cycle power to the controller after downloading the Ethernet port configuration to enable the DNP3 over IP feature.

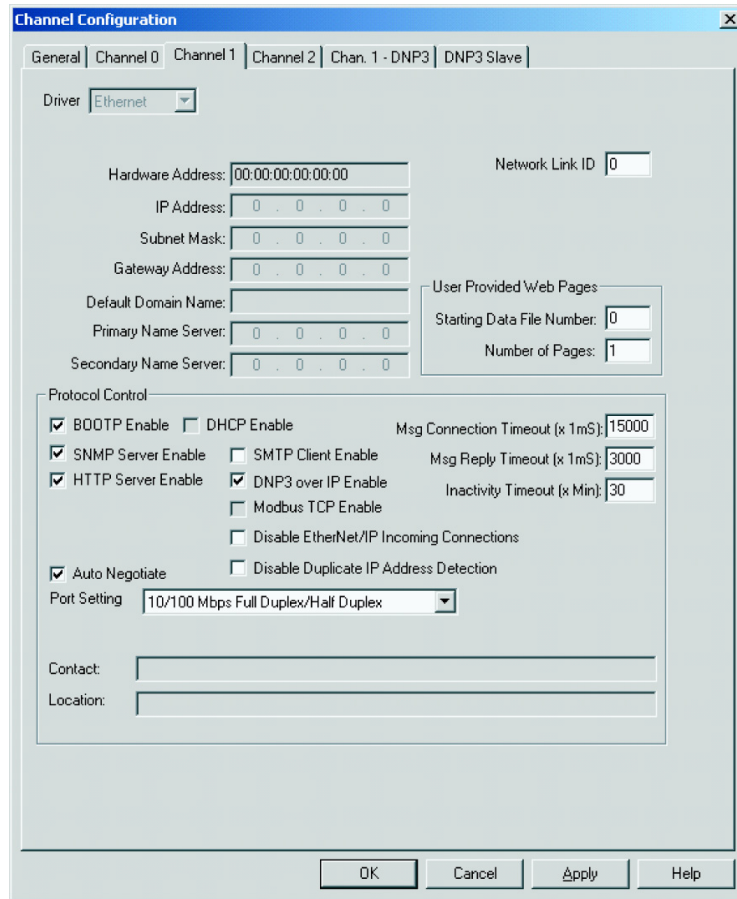

Link Layer related configuration can also be done in the Chan. 1 - DNP3 tab.

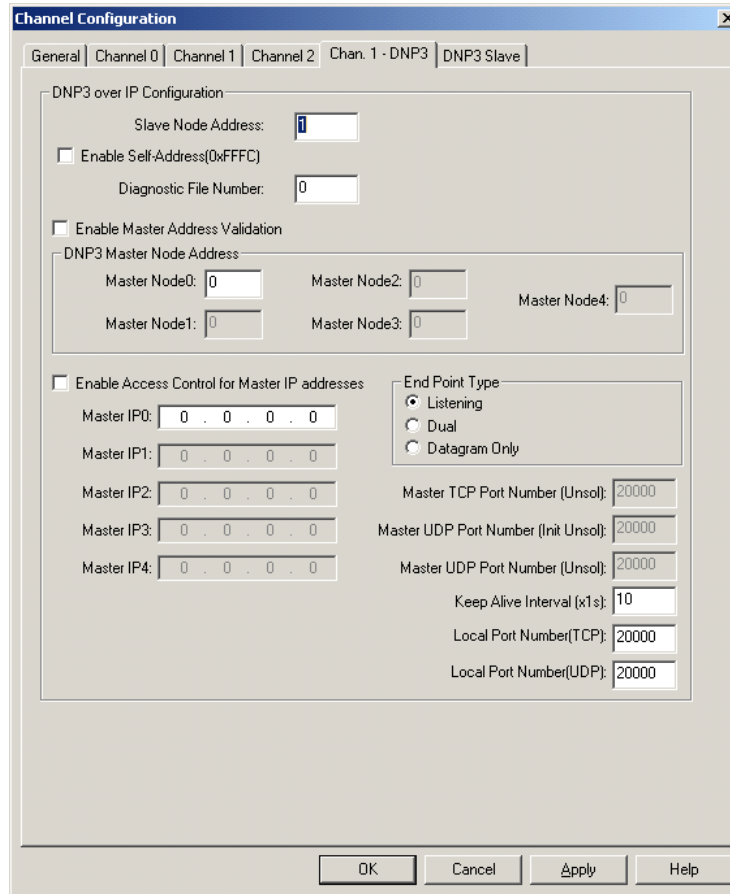

DNP3 Slave Application Layer Configuration

Application Layer related configuration can be done in the DNP3 Slave tab.

For the MicroLogix 1400 Series A controllers, you can see the following tabs.

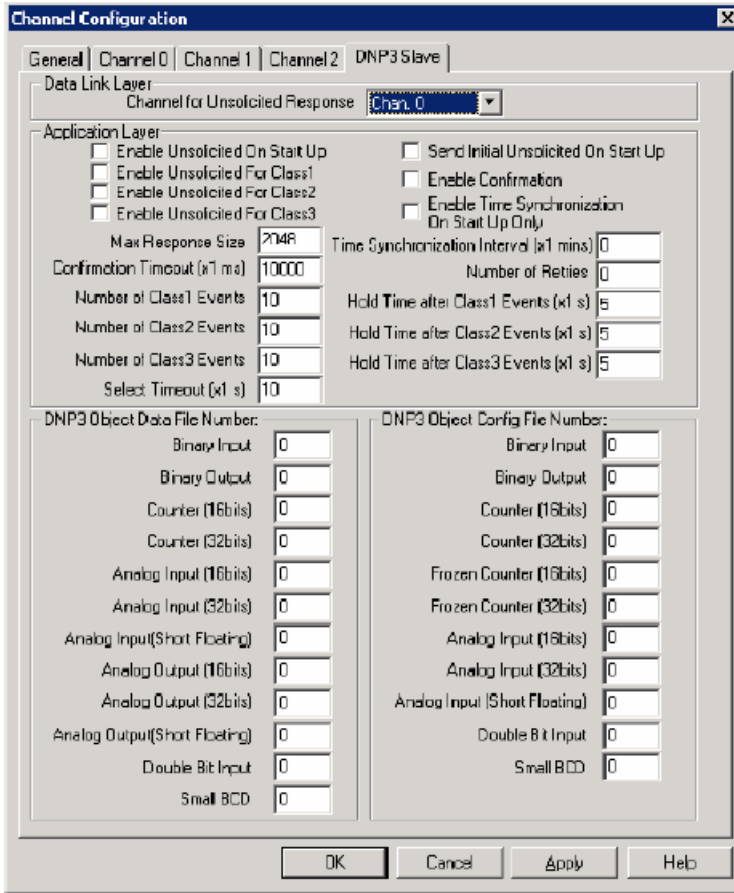

If you want to communicate with DNP3 protocol using Channel 0 port, both Channel 0 and DNP3 Slave configurations should be set. If you want to communicate with DNP3 protocol using Channel 2 port, Channel 2 and DNP3 Slave configurations should be set.

If you want to communicate with DNP3 protocol using both Channel 0 port and Channel 2 port, Channel 0, Channel 2 and DNP3 Slave configurations should be set.

In this case, the channel which is directed in DNP3 Slave configuration supports full functionality. But, the other port supports limited functionality and it does not support some features like Unsolicited Response.

DNP3 Slave configuration is shared by both Channel 0 and Channel 2 ports if the Channel 0 and Channel 2 are configured to DNP3 protocol. Any changes in DNP3 Slave configuration tab will affect both channels.

For the MicroLogix 1400 Series B and Series C controllers, you can see the following tabs.

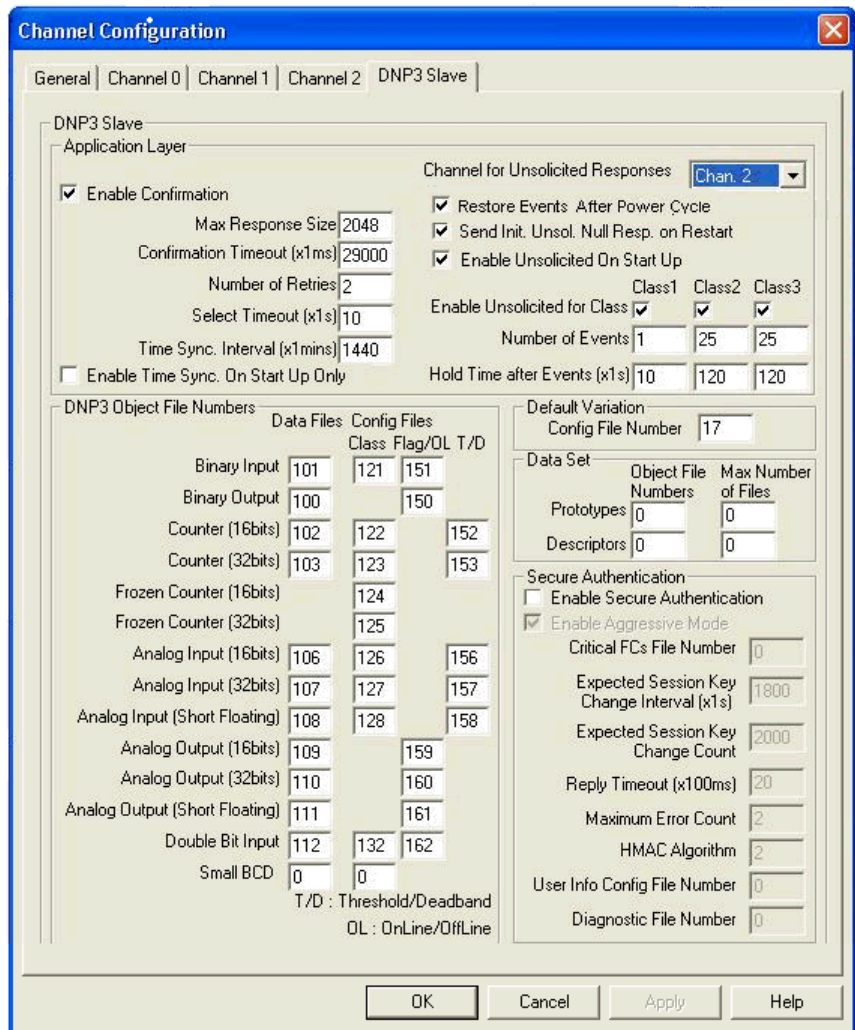

DNP3 Slave configuration is shared by Channel 0, Channel 1 and Channel 2 ports if Channels 0, 1 and 2 are configured for DNP3 protocol. Any changes in the DNP3 Slave configuration tab will affect all channels.

Channel 0 and Channel 2 Link Layer Configuration Parameters

Driver

This selection should be set to DNP3 Slave to communicate with DNP3 protocol.

Node Address

This value is a node address of this DNP3 Slave.
The valid range is 0 to 65519.
Default value is 1.

Baud

The selections can be "38.4 K", "19200", "9600", "4800", "2400", "1200", "600", and "300".
Default selection is "19200".

Parity

The selections can be "NONE", "EVEN", and "ODD". Default selection is "NONE".

Stop Bits

The selections can be "1", "1.5", and "2".
Default selection is "1".

Enable Master Address Validation

Valid selections are Enabled(Checked) and Disabled(Unchecked). Default value is Disabled (Unchecked).

When the selection is Disabled(Unchecked), the MicroLogix 1400 accepts the requests from any DNP3 Master.

When the selection is Enabled(Checked), the MicroLogix 1400 accepts the requests only from the DNP3 Master which is configured in the Master Node0 to Master Node4. The maximum number of Master Node Addresses for the Master Address Validation is 5.

Enable Self-Address

Valid selections are Enabled(Checked) and Disabled(Unchecked). Default value is Disabled (Unchecked).

When this bit is Disabled(Unchecked), any packets which contain the destination address 65532(FFFCh) are ignored.

When this bit is Enabled(Checked), any packets which contain the destination address 65532(FFFCh) are accepted and processed.

Master Node0

This value is used to:

- validate the Master node address when the Enable Master Address Validation is Enabled (Checked)
- send Unsolicited Response when Unsolicited Response functionality is enabled. An Unsolicited Response is sent out to the DNP3 Master having this address.

The valid range is 0 to 65519. Default value is 0.

Master Node1, Master Node2, Master Node3, Master Node4

The valid range is 0 to 65519. Default value is 0.

This value is used to check validation for Master node address when Enable Master Address Validation is Enabled (Checked).

Control

For Channel 0, the selections can be No Handshaking, Half Duplex Modem(CTS/RTS handshaking) and No Handshaking (485 Network). Default selection is No Handshaking.

For Channel 2, the selections can be No Handshaking, and Half Duplex Modem(CTS/RTS handshaking). Default selection is No Handshaking.

When the MicroLogix 1400 is connected to DNP3 Master using RS-232 line directly, you must select No Handshaking. If you want to use the Modem line in a half duplex network, you must select Half Duplex Modem(CTS/RTS handshaking). If the MicroLogix 1400 is connected to an RS-485 network and a 1763-NC01 cable is used, you must select No Handshaking (485 Network).

If you want to send an ASCII string via a serial channel which is configured to DNP3 Slave protocol, use AWA and AWT instructions to control the Modem.

For Cabling and Connections, see [Communication Connections on page 75](#).

For AWA and AWT instructions, refer to the MicroLogix 1400 Programmable Controllers Instruction Set Reference Manual, [1766-RM001](#).

Request LL Confirmation

Valid selections are Enabled (Checked) and Disabled (Unchecked). Default value is Disabled (Unchecked).

When the selection is Disabled (Unchecked), Primary Frames from the MicroLogix 1400 are sent out with the function code FC_UNCONFIRMED_USER_DATA (4).

When the selection is Enabled (Checked), Primary Frames from the MicroLogix 1400 are sent out with the function code FC_CONFIRMED_USER_DATA (3). In this case, the MicroLogix 1400 waits for the confirmation and may retry the Frame if it did not receive the confirmation from DNP3 Master within the time Confirmation Timeout (x1 ms).

Send LL Confirmation

Valid selections are Enabled (Checked) and Disabled (Unchecked). Default value is Disabled (Unchecked).

When the selection is Disabled (Unchecked), the optional Secondary Frame is not sent out with the function code FC_NACK (1) or FC_NOT_SUPPORTED (15).

When the selection is Enabled (Checked), the optional Secondary Frame is sent out with the function code FC_NACK (1) or FC_NOT_SUPPORTED (15).

Confirmation Timeout (x20 ms)

When Request LL Confirmation is enabled, the MicroLogix 1400 waits to receive a confirmation frame until this timeout has expired.

The valid range is 1...65535. Default value is 1.

Message Retries

When Confirmation Timeout (x1 ms) has expired and this parameter was non-zero value, the MicroLogix 1400 tries to send retry packets.

The valid range is 0...255. Default value is 0.

Pre Transmit Delay (x1 ms)

The MicroLogix 1400 waits for the specified time before sending the packet.

The valid range is 0...65535. Default value is 0.

RTS Off Delay (x20 ms)

When the Control is set at Half Duplex Modem(CTS/RTS handshaking), this feature is enabled. This specifies a time delay between the end of a transmission and dropping of the RTS signal.

The valid range is 0...65535. Default value is 0.

RTS Send Delay (x20 ms)

When the Control is set at Half Duplex Modem(CTS/RTS handshaking), this entry is enabled. This specifies a time delay between the raising of the RTS and the initiation of a transmission.

The valid range is 0...65535. Default value is 0.

Max Random Delay (x1 ms)

This parameter is used with Pre Transmit Delay (x1 ms) for Collision Avoidance on RS-485 network. For more details, see [Collision Avoidance on page 344](#).

The valid range is 0...65535. Default value is 0.

Channel 1(Ethernet) Link Layer Configuration Parameters

This section is only applicable to MicroLogix 1400 Series B and Series C controllers.

The DNP3 over IP subsystem in the MicroLogix 1400 supports Listening End Point, TCP Dual End Point and Datagram End Point type.

Listening End Point type supports a single TCP connection as a Server and UDP datagram.

TCP Dual End Point type supports a single TCP connection as a Server, a single TCP connection as a Client and UDP datagram.

Datagram End Point type supports UDP datagram from DNP3 Masters. The default TCP and UDP port numbers are 20000 and the port numbers are configurable.

The End Point type can be determined by the parameter End Point Type. According to the parameter, the MicroLogix 1400 works as different End Point types. See the following table for each configuration.

End Point Types

End Point Type	Connection	Description
Listening End Point	A single TCP Server connection	Any of the requests are accepted and the responses are transmitted via this connection. The unsolicited responses are transmitted via this connection when this connection is available.
	UDP datagram	Accepts only broadcast packets when DNP3 destination node is one of 0xFFFFD, 0xFFFFE and 0xFFFFF in the request.
Dual End Point	A single TCP Server connection	Any of the requests are accepted and the responses are transmitted via this connection. The unsolicited responses are transmitted via this connection when this connection is available. This connection has higher priority than the Client connection.
	A single TCP Client connection	Any of the requests are accepted and the responses are transmitted via this connection. The unsolicited responses are transmitted via this connection when this connection is available. The MicroLogix 1400 does not request TCP client connection to DNP3 Master until an unsolicited response is generated.
Datagram End Point	UDP Datagram	Accepts only broadcast packets when DNP3 destination node is one of 0xFFFFD, 0xFFFFE and 0xFFFFF in the request.
	UDP Datagram only	Any of the requests are accepted and the responses are transmitted via this connection. All responses can be transmitted to the different DNP3 Master port according to the configuration of the parameters Remote UDP Port Number and Master IP Address0. If this parameter is not set to 0, the solicited responses are sent to the DNP3 Master port that is configured. If this parameter is set to 0, the solicited responses are sent to the DNP3 Master port that sent the request. TCP connection is not available in this configuration.

The parameter DNP3 over IP Enable is configured in the Channel 1 tab and other parameters are configured in the Chan. 1 - DNP3 tab.

DNP3 over IP Enable

The valid selections are Enabled (Checked) and Disabled (Unchecked). Default value is Disabled (Unchecked). Power cycle is required for changes to take effect.

When the selection is Disabled (Unchecked), DNP3 service over Ethernet is disabled after power-cycle.

When the selection is Enabled (Checked), DNP3 service over Ethernet is enabled after power-cycle.

Enable Master Address Validation

The valid selections are Enabled(Checked) and Disabled(Unchecked). Default value is Disabled (Unchecked).

When the selection is Disabled(Unchecked), the MicroLogix 1400 accepts the requests from any DNP3 Master.

When the selection is Enabled(Checked), the MicroLogix 1400 accepts the requests only from the DNP3 Master Node Address which is configured in the parameters [Master Node0 on page 266](#), and [Master Node1, Master Node2, Master Node3, Master Node4 on page 267](#). The maximum number of Master Node Address for the Master Address Validation is 5.

Enable Self-Address

The valid selections are Enabled(Checked) and Disabled(Unchecked). Default value is Disabled (Unchecked).

When this bit is Disabled(Unchecked), any packets which contain the destination address 65532(FFFCh) are ignored.

When this bit is Enabled(Checked), any packets which contain the destination address 65532(FFFCh) are accepted and processed.

Enable Access Control

The valid selections are Enabled(Checked) and Disabled(Unchecked). Default value is Disabled (Unchecked).

When the selection is Disabled(Unchecked), the MicroLogix 1400 accepts the requests from any DNP3 Master.

When the selection is Enabled(Checked), the MicroLogix 1400 accepts the requests only from the DNP3 Master IP Address which is configured in the parameters Master IP Address0 to Master IP Address4. The maximum number of Master IP Address for the Access Control is 5.

End Point Type

The valid selections are Listening, Dual and Datagram Only.

Default is Listening End Point Type.

Master Node0

This value is used to:

- validate Master node address when the Enable Master Address Validation is Enabled (Checked)
- send Unsolicited Response when Unsolicited Response functionality is enabled. An Unsolicited Response is sent out to the DNP3 Master having this address.

The valid range is 0 to 65519. Default value is 0.

Master Node1, Master Node2, Master Node3, Master Node4

This value is used for validation of the Master node address when the Enable Master Address Validation is Enabled (Checked). This value is only valid when the Enable Master Address Validation is Enabled (Checked).

The valid range is 0 to 65519. Default value is 0.

Master IP Address0

This value is used to:

- validate Master IP address when the Enable Access Control is Enabled (Checked)
- send Unsolicited Response when Unsolicited Response functionality is enabled. An Unsolicited Response is sent out to the DNP3 Master having this address.

The valid value is an IP address. Default value is 0.0.0.0.

Master IP Address1, Master IP Address2, Master IP Address3, Master IP Address4

This value is used for validation of the Master IP address when the Enable Access Control is Enabled (Checked). This value is only valid when the Enable Access Control is Enabled (Checked).

The valid value is an IP address. Default value is 0.0.0.0.

Remote TCP Port Number

This value is used to configure Master TCP Port Number for Unsolicited Response.

The valid range is 0 to 65535. Default value is 20000.

Remote UDP Port Number for Initial Unsolicited

This value is used to configure Master UDP Port Number for Initial Unsolicited Response if the parameter End Point Type is selected as Datagram Only.

The valid range is 0 to 65535. Default value is 20000.

Remote UDP Port Number

This value is used to configure Master UDP Port Number if the parameter End Point Type is selected as Datagram Only.

The valid range is 0 to 65535. Default value is 20000.

Keep Alive Interval (x1 s)

This parameter specifies a time interval for TCP Keep Alive mechanism.

If the timer times out, the MicroLogix 1400 transmits a keep-alive message. The keep-alive message is a DNP Data Link Layer status request (FC_REQUEST_LINK_STATUS). If a response is not received to the keep-alive message, the MicroLogix 1400 deems the TCP connection broken and closes the TCP connection.

The valid range is 1 to 65535. Default value is 10.

Slave Node Address

This value is a node address of this DNP3 Slave.

The valid range is 0 to 65519. Default value is 1.

Local TCP Port Number

This value is used to configure Local TCP Port Number which is used for TCP socket listening.

The valid range is 0 to 65535. Default value is 20000.

Local UDP Port Number

This value is used to configure Local UDP Port Number which is used for UDP socket listening.

The valid range is 0 to 65535. Default value is 20000.

Diagnostic File Number

The diagnostic file number is used to store the diagnostics for the troubleshooting of DNP3 Ethernet subsystem. The status of DNP3 TCP and UDP subsystem is stores to this data file.

The value of this parameter is N file only. Valid range is 0, 7, 9 to 255. Default value is 0.

See [Diagnostics on page 354](#).

DNP3 Slave Application Layer Configuration Parameters

Channel for Unsolicited Response

Only channels already configured for DNP3 protocol appear in the Channel for Unsolicited Response dropdown menu. Any and all Unsolicited Responses are transmitted via this selected channel.

Channel 1 is only supported in MicroLogix 1400 Series B and Series C controllers.

Valid selections are enabled (checked) and disabled (unchecked), with disabled as default value.

Restore Events After Power Cycle

When the selection is disabled (unchecked), DNP3 events which are generated before a power cycle are flushed after a power cycle. When the option is enabled (checked), all DNP3 events are restored after a power cycle.

Enable Unsolicited On Start Up

Valid selections are Enabled (Checked) and Disabled (Unchecked). Default value is Disabled (Unchecked).

When the selection is Disabled (Unchecked), the MicroLogix 1400 will not send any enabled Unsolicited Responses after a restart until it has received a FC_ENABLE_UN SOLICITED (20) command from the DNP3 Master..

When the selection is Enabled (Checked), the MicroLogix 1400 will send any enabled Unsolicited Responses after a restart to the DNP3 Master unconditionally

Enable Unsolicited For Class1

Valid selections are Enabled (Checked) and Disabled (Unchecked). Default value is Disabled (Unchecked).

When the selection is Disabled (Unchecked), Unsolicited Response is disabled for Class 1 events. To prevent overflowing of the event buffer, DNP3 Master should poll for Class 1 events.

When the selection is Enabled (Checked), Unsolicited Response is enabled for Class 1 events.

Enable Unsolicited For Class2

Valid selections are Enabled (Checked) and Disabled (Unchecked). Default value is Disabled (Unchecked).

When the selection is Disabled (Unchecked), Unsolicited Response is disabled for Class 2 events. To prevent overflowing of the event buffer, DNP3 Master should poll for Class 2 events.

When the selection is Enabled (Checked), Unsolicited Response is enabled for Class 2 events.

Enable Unsolicited For Class3

Valid selections are Enabled (Checked) and Disabled (Unchecked). Default value is Disabled (Unchecked).

When the selection is Disabled (Unchecked), Unsolicited Response is disabled for Class 3 events. To prevent overflowing of the event buffer, DNP3 Master should poll for Class 3 events.

When the selection is Enabled (Checked), Unsolicited Response is enabled for Class 3 events.

Send Initial Unsolicited Null Response On Start Up

Valid selections are Enabled (Checked) and Disabled (Unchecked). Default value is Disabled (Unchecked).

When the selection is Disabled (Unchecked), the MicroLogix 1400 does not send Unsolicited NULL Response with RESTART IIN bit on startup.

When the selection is Enabled (Checked), the MicroLogix 1400 sends Unsolicited NULL Response with RESTART IIN bit on startup.

This selection is also used for sending the Restart IIN bit during Driver and Channel configuration changes. [See Internal Indications on page 289](#) for details.

Enable Confirmation

Valid selections are Enabled (Checked) and Disabled (Unchecked). Default value is Disabled (Unchecked).

When the selection is Disabled (Unchecked), the MicroLogix 1400 sends Response packets with CON bit set in its header under the following conditions only:

- When the response has Event data.
- When the response is multi-fragment response.

- When the Unsolicited Response is sent.

When the selection is Enabled (Checked), the MicroLogix 1400 always sends Response packets with the CON bit set in its header, which causes the DNP3 Master to send replies confirming that it received each Response packet without error.

Enable Time Synchronization On Start Up Only

Valid selections are Enabled (Checked) and Disabled (Unchecked). Default value is Disabled (Unchecked).

This parameter used with Time Synchronization Interval (x1 mins).

When the selection is Disabled (Unchecked), the MicroLogix 1400 sets IIN1.4 bit on power up and every interval configured in Time Synchronization Interval (x1 mins).

When the selection is Enabled (Checked), the MicroLogix 1400 only sets the NEED_TIME Internal Indication bit (IIN1.4) upon startup.

Time Synchronization Interval (x1 mins)

This parameter used with Enable Time Synchronization On Start Up Only. Only valid when Enable Time Synchronization On Start Up Only is Disabled (Unchecked).

The valid range is 0...32767. Default value is 0. As long as it is set for greater than 0, the NEED_TIME Internal Indication (IIN1.4) bit will be set at startup and then after every Time Synchronization Interval minutes.

When the parameter Enable Time Synchronization On Start Up Only is Disabled (Unchecked) and the parameter Time Synchronization Interval (x1 mins) is configured to 0, IIN1.4 bit is never turned on.

Max Response Size

The MicroLogix 1400 sends Application Layer frame to fit in Max Response Size. If the Response packet size is larger than this value, the MicroLogix 1400 fragments the Response packet.

The valid range is 27...2048 in bytes. Default value is 2048.

Confirmation Timeout (x1 ms)

When Enable Confirmation is enabled, the MicroLogix 1400 waits for Application Layer Confirmation until the Confirmation Timeout (x1 ms) has expired.

The valid range is 100...65535 in 1ms increments. Default value is 10000.

Number of Retries

This parameter is only for Unsolicited Response. If this value has the maximum which is 65535, it means infinite retries of the Unsolicited Response.

The valid range is 0...65535. Default value is 0.

Number of Class1 Events

If the MicroLogix 1400 is configured not to initiate Unsolicited Response, this parameter used to limit the maximum number of events which is generated and logged into the event buffer for Class 1 events. In this case, value 0 will disable to generate the event.

If the MicroLogix 1400 is configured to generate Unsolicited Response, and the number of queued Class 1 events is reached to this value, Unsolicited Response is initiated.

The valid range is 0 to 6013 or 0 to 10000 (see [DNP3 10K Event Logging on page 338](#)). Default value is 10.

Hold Time after Class1 Events (x1 s)

This parameter is only for Unsolicited Response. The MicroLogix 1400 holds the events during Hold Time after Class1 Events (x1 s) before initiating an Unsolicited Response.

The valid range is 0...65535. Default value is 5.

The value of 0 indicates that responses are not delayed due to this parameter.

Note that parameters Number of Class1 Events and Hold Time after Class1 Events (x1 s) are used together so that if either one of the criteria are met, an Unsolicited Response is transmitted.

By default, the Hold time is re-triggered for each new event detected.

You can choose not to re-trigger the hold timer for each new event detected by setting Status Bit S:36/12 to 1 before downloading to the controller. The default state of this Status Bit S:36/12 is 0.

Number of Class2 Events

If the MicroLogix 1400 is configured not to initiate Unsolicited Response, this parameter used to limit the maximum number of events which is generated and logged into the event buffer for Class 2 events. In this case, value 0 will disable to generate the event.

If the MicroLogix 1400 is configured to generate Unsolicited Response, and the number of queued Class 2 events is reached to this value, Unsolicited Response is initiated.

The valid range is 0 to 6013 or 0 to 10000 (see [DNP3 10K Event Logging on page 338](#)). Default value is 10.

Hold Time after Class2 Events (x1 s)

This parameter is only for Unsolicited Response. The MicroLogix 1400 holds the events during Hold Time after Class2 Events (x1 s) before initiating an Unsolicited Response.

The valid range is 0 to 65535. Default value is 5.

The value of 0 indicates that responses are not delayed due to this parameter.

Note that parameters Number of Class2 Events and Hold Time after Class2 Events (x1 s) are used together so that if either one of the criteria are met, an Unsolicited Response is transmitted.

By default, the Hold time is re-triggered for each new event detected.

You can choose not to re-trigger the hold timer for each new event detected by setting Status Bit S:36/12 to 1 before downloading to the controller. The default state of this Status Bit S:36/12 is 0.

Number of Class3 Events

If the MicroLogix 1400 is configured not to initiate Unsolicited Response, this parameter used to limit the maximum number of events which is generated and logged into the event buffer for Class 3 events. In this case, value 0 will disable to generate the event.

If the MicroLogix 1400 is configured to generate Unsolicited Response, and the number of queued Class 3 events is reached to this value, Unsolicited Response is initiated.

The valid range is 0 to 6013 or 0 to 10000 (see [DNP3 10K Event Logging on page 338](#)). Default value is 10.

Hold Time after Class3 Events (x1 s)

This parameter is only for Unsolicited Response. The MicroLogix 1400 holds the events during Hold Time after Class3 Events (x1 s) before initiating an Unsolicited Response.

The valid range is 0 to 65535. Default value is 5.

The value of 0 indicates that responses are not delayed due to this parameter.

Note that parameters Number of Class3 Events and Hold Time after Class3 Events (x1 s) are used together so that if either one of the criteria are met, an Unsolicited Response is transmitted.

By default, the Hold time is re-triggered for each new event detected.

You can choose not to re-trigger the hold timer for each new event detected by setting Status Bit S:36/12 to 1 before downloading to the controller. The default state of this Status Bit S:36/12 is 0.

Select Timeout (x1 s)

The valid range is 1...65535. Default value is 10.

This parameter is used for controlling CROB (Control Relay Output Block) and AOB (Analog Output Block). After receiving the request with the function code FC_SELECT(3), DNP3 Master should send the request with the function code FC_OPERATE(4) within this configured time.

DNP3 Object Data File Number

The DNP3 Object Data File Numbers define the mapping of the listed DNP3 objects to MicroLogix 1400 data table files. The number of elements defined for each of those data table files also defines the number of corresponding DNP3 objects.

See [DNP3 Objects and MicroLogix 1400 Data Files on page 290](#) for more details.

DNP3 Object Config File Number

The DNP3 Object Config File Numbers define the mapping of the listed DNP3 object properties (class number, online/offline status, object quality flags, deadbands and/or thresholds) to MicroLogix 1400 data table files.

See [DNP3 Objects and MicroLogix 1400 Data Files on page 290](#) for more details.

DNP3 Secure Authentication

This section is applicable only to MicroLogix 1400 Series B and Series C controllers.

The MicroLogix 1400 implements the DNP3 Secure Authentication based on the DNP3 Specification, Supplement to Volume 2, Secure Authentication, Version 2.00.

DNP3 Secure Authentication has been implemented in the DNP3 Application Layer of the MicroLogix 1400 system. If you configure any parameters regarding DNP3 Secure Authentication in the DNP3 Slave Application Layer configuration, it affects all ports which are configured for DNP3 protocol in the MicroLogix 1400 controller.

Enable Secure Authentication

This parameter is supported only in MicroLogix 1400 Series B and Series C controllers.

The valid selections are Enabled (Checked) and Disabled (Unchecked). Default value is Disabled (Unchecked).

When the selection is Disabled (Unchecked), the MicroLogix 1400 disables DNP3 Secure Authentication subsystem.

When the selection is Enabled (Checked), the MicroLogix 1400 enables DNP3 Secure Authentication subsystem.

Enable Aggressive Mode in Secure Authentication

This parameter is supported only in MicroLogix 1400 Series B and Series C controllers.

The valid selections are Enabled (Checked) and Disabled (Unchecked). Default value is Enabled (Checked).

When the selection is Disabled (Unchecked), the MicroLogix 1400 disables DNP3 Aggressive Mode in Secure Authentication subsystem.

When the selection is Enabled (Checked), the MicroLogix 1400 enables DNP3 Aggressive Mode in Secure Authentication subsystem.

Critical FCs File Number in Secure Authentication

This parameter is supported only in MicroLogix 1400 Series B and Series C controllers.

This file number is used to define the list of the critical function codes in Secure Authentication. A critical function code should be defined in a word element in this file. The maximum number of element in this file should not exceed 32(the maximum number of the function codes that can be defined).

The value of this parameter is N file only. Valid range is 0, 7, 9 to 255. Default value is 0.

When this file number is configured to 0 and there is no configuration file assigned, some function codes are considered as critical by default. See the table

below for the critical function codes. When this file number of this parameter is not 0 and it is a valid N data file, all function codes are considered as non-critical. In this case, you must define all critical function codes in this file.

Note that the function code 0(FC_CONFIRM) is considered as critical once the file number is configured newly. If you don't want the function code 0 to be considered as critical, the number of elements in the file should be adjusted and the element value 0 should not be in any elements.

Function Code	Critical FCs File Number = 0	Critical FCs File Number = 0
0 (0x00)	-	optional
1 (0x01)	-	optional
2 (0x02)	critical	optional
3 (0x04)	critical	optional
4 (0x04)	critical	optional
5 (0x05)	critical	optional
6 (0x06)	critical	optional
7 (0x07)	-	optional
8 (0x08)	-	optional
9 (0x09)	-	optional
10 (0x0A)	-	optional
11 (0x0B)	-	-
12 (0x0C)	-	-
13 (0x0D)	critical	optional
14 (0x0E)	critical	optional
15 (0x0F)	N.A.	N.A.
16 (0x10)	critical	optional
17 (0x11)	critical	optional
18 (0x12)	critical	optional
19 (0x13)	N.A.	N.A.
20 (0x14)	critical	optional
21 (0x15)	critical	optional
22 (0x16)	-	-
23 (0x17)	-	optional
24 (0x18)	critical	optional
25 (0x19)	-	optional
26 (0x1A)	-	optional
27 (0x1B)	-	optional
28 (0x1C)	-	optional
29 (0x1D)	critical	optional
30 (0x1E)	-	optional
31 (0x1F)	critical	optional

Function Code	Critical FCs File Number = 0	Critical FCs File Number = 0
32 (0x20)	N.A.	N.A.
33 (0x21)	N.A.	N.A.
129 (0x81)	-	optional
130 (0x82)	-	optional
131 (0x83)	N.A.	N.A.

Expected Session Key Change Interval (x1 s) in Secure Authentication

This parameter is supported only in MicroLogix 1400 Series B and Series C controllers.

This parameter is used for configuring the expected session key change interval in seconds.

The valid range is 0...7200 (2 hrs). Default value is 1800 (30 mins).

When DNP3 Master does not change the Session Key within this time configured, the MicroLogix 1400 invalidate the Session Key and its state for each user.

Expected Session Key Change Count in Secure Authentication

This parameter is supported only in MicroLogix 1400 Series B and Series C controllers.

This parameter is used for configuring the expected session key change count.

The valid range is 1 to 10000. Default value is 2000.

Reply Timeout (x100 ms) in Secure Authentication

This parameter is supported only in MicroLogix 1400 Series B and Series C controllers.

This parameter is used for configuring the reply timeout in 100 msec.

The valid range is 0...1200 (120 s). Default value is 20 (2 s).

Maximum Error Count in Secure Authentication

This parameter is supported only in MicroLogix 1400 Series B and Series C Controllers.

This parameter is used for configuring the maximum error count.

The valid range is 0...10. Default value is 2.

HMAC Algorithm in Secure Authentication

This parameter is supported only in MicroLogix 1400 Series B and Series C controllers.

This parameter is used for configuring the HMAC Algorithm.

- 1 = HMAC SHA-1 truncated to 4 octets (serial)
- 2 = HMAC SHA-1 truncated to 10 octets (networked)
- 3 = HMAC SHA-256 truncated to 8 octets (serial)
- 4 = HMAC SHA-256 truncated to 16 octets (networked)

The valid range is 1...4. Default value is 2.

User Info Config File Number in Secure Authentication

This parameter is supported only in MicroLogix 1400 Series B and Series C controllers.

This file number is used to define user information Secure Authentication.

The value of this parameter is N file only. Valid range is 0, 7, 9...255. Default value is 0.

In RSLogix 500/RSLogix Micro software, when this parameter is configured properly, you can see a DNP3 Auth User Info Config File tree in Channel Configuration.

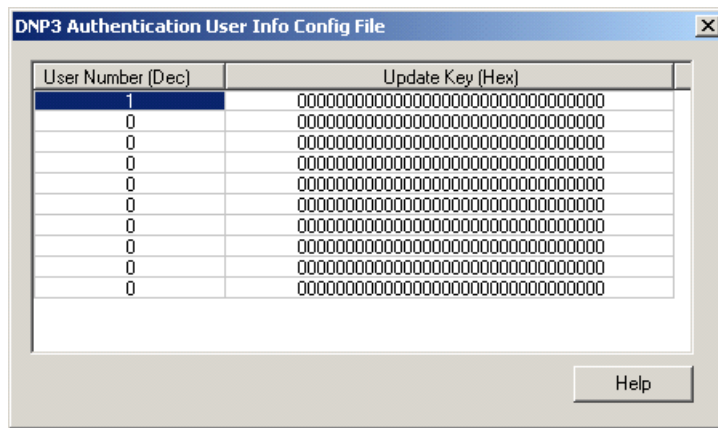
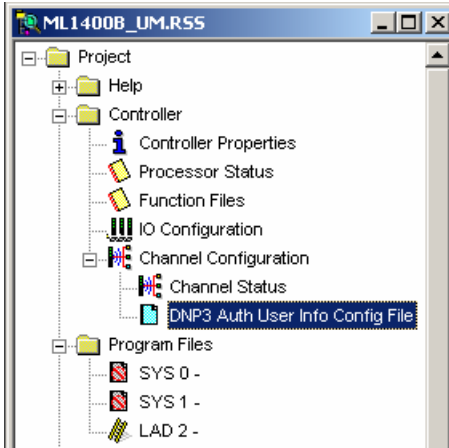

The following table shows the structure of the DNP3 Secure Authentication User Info Configuration File. An Update Key is made up of 16 bytes and must be entered in as 32 hexadecimal digits.

DNP3 Secure Authentication User Info Configuration File Structure

Word Offset	Name	Default Value By Controller (DEC)	Default Value By RSLogix500 (DEC)	Valid Range (DEC)	Description
0	User Number	0	1	0 to 65535	For User 1
1	Reserved	0	0	0	For User 1
2	Update Key (0)	0	0	0 to 65535	
3	Update Key (1)	0	0	0 to 65535	
4	Update Key (2)	0	0	0 to 65535	
5	Update Key (3)	0	0	0 to 65535	
6	Update Key (4)	0	0	0 to 65535	
7	Update Key (5)	0	0	0 to 65535	

DNP3 Secure Authentication User Info Configuration File Structure

Word Offset	Name	Default Value By Controller (DEC)	Default Value By RSLogix500 (DEC)	Valid Range (DEC)	Description
8	Update Key (6)	0	0	0 to 65535	
9	Update Key (7)	0	0	0 to 65535	
10	User Number	0	0	0 to 65535	For User 2
11	Reserved	0	0	0	For User 1
12	Update Key (0)	0	0	0 to 65535	
13	Update Key (1)	0	0	0 to 65535	
14	Update Key (2)	0	0	0 to 65535	
15	Update Key (3)	0	0	0 to 65535	
16	Update Key (4)	0	0	0 to 65535	
17	Update Key (5)	0	0	0 to 65535	
18	Update Key (6)	0	0	0 to 65535	
19	Update Key (7)	0	0	0 to 65535	
...					
90	User Number	0	0	0 to 65535	For User 10
91	Reserved	0	0	0	For User 10
92	Update Key (0)	0	0	0 to 65535	
93	Update Key (1)	0	0	0 to 65535	
94	Update Key (2)	0	0	0 to 65535	
95	Update Key (3)	0	0	0 to 65535	
96	Update Key (4)	0	0	0 to 65535	
97	Update Key (5)	0	0	0 to 65535	
98	Update Key (6)	0	0	0 to 65535	
99	Update Key (7)	0	0	0 to 65535	

Diagnostic File Number in Secure Authentication

This parameter is supported only in MicroLogix 1400 Series B and Series C controllers.

The diagnostic file number is used to store the diagnostics for the troubleshooting of DNP3 Secure Authentication subsystem.

The value of this parameter is N file only. Valid range is 0, 7, 9 to 255. Default value is 0.

See the table for the contents of the data file in the section Diagnostics.

Default Variation Config File Number

This parameter is supported only in MicroLogix 1400 Series B and Series C controllers.

This file number is used to define default variations in a response to a Class 0 poll request.

The value of this parameter is N file only. Valid range is 0, 7, 9 to 255. Default value is 0.

In RSLogix 500/RSLogix Micro software, when this parameter is configured properly, you can see a DNP3 Default Variation Config File tree in Channel Configuration.

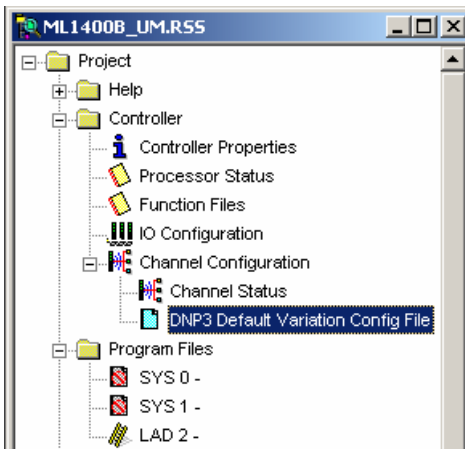

The screenshot shows a dialog box titled 'DNP3 Default Variation Config File' containing a table with the following data:

Object Name	Group (Dec)	Variation (Dec)
Binary Input Static Object	1	1
Binary Input Change Object	2	3
Binary Output Static Object	10	2
Double Bit Binary Input Static Object	3	1
Double Bit Binary Input Change Object	4	3
16bits Counter Static Object	20	6
32bits Counter Static Object	20	5
Frozen 16bits Counter Static Object	21	10
Frozen 32bits Counter Static Object	21	9
16bits Counter Change Object	22	2
32bits Counter Change Object	22	1
Frozen 16bits Counter Change Object	23	2
Frozen 32bits Counter Change Object	23	1
16bits Analog Input Static Object	30	4
32bits Analog Input Static Object	30	3
Short Floating Point Analog Input Static Object	30	5
16bits Analog Input Change Object	32	2
32bits Analog Input Change Object	32	1
Short Floating Point Analog Input Change Object	32	5
16bits Analog Output Static Object	40	2
32bits Analog Output Static Object	40	1
Short Floating Point Analog Output Static Object	40	3
Small BCD Object	101	1

The following table shows the structure of the DNP3 Default Variation Configuration File.

Table 2.1

Word Offset	Default Variation for the following Objects	Group and Standard Default Variation	Alternate Default Variations
0	Binary Input Static Object	g1v1	v2
1	Binary Input Change Object	g2v3	v1, v2
2	Binary Output Static Object	g10v2	none
3	Reserved	-	
4	Double Bit Binary Input Static Object	g3v1	v2
5	Double Bit Binary Input Change Object	g4v3	v1, v2
6	16-bit Counter Static Object	g20v6	v2
7	32-bit Counter Static Object	g20v5	v1
8	Frozen 16-bit Counter Static Object	g21v10	v2, v6
9	Frozen 32-bit Counter Static Object	g21v9	v1, v5
10	16-bit Counter Change Object	g22v2	none
11	32-bit Counter Change Object	g22v1	none
12	Frozen 16-bit Counter Change Object	g23v2	v6
13	Frozen 32-bit Counter Change Object	g23v1	v5
14	16-bit Analog Input Static Object	g30v4	v2
15	32-bit Analog Input Static Object	g30v3	v1
16	Short Floating Point Analog Input Static Object	g30v5	none
17	16-bit Analog Input Change Object	g32v2	v4
18	32-bit Analog Input Change Object	g32v1	v3
19	Short Floating Point Analog Input Change Object	g32v5	v7
20	16-bit Analog Output Static Object	g40v2	none
21	32-bit Analog Output Static Object	g40v1	none
22	Short Floating Point Analog Output Static Object	g40v3	none
23	Reserved	-	
24	Reserved	-	
25	Reserved	-	
26	Small BCD Object	g101v1	none
27	Reserved	-	
28	Reserved	-	
29	Reserved	-	
30	Reserved	-	
31	Reserved	-	

Disable EtherNet/IP Incoming Connections

IMPORTANT You cannot disable the Ethernet/IP Incoming Connections if both serial Channels 0 and 2 are already configured as disabled.
See also [Appendix G](#) for the alternative way to disable the Ethernet channel.

If you have a critical application and do not want to allow any Ethernet/IP Incoming Connections, use the parameter Disable Ethernet/IP Incoming Connections.

1. From the Channel 1 Ethernet Channel Configuration tab, click the check box to disable the EtherNet/IP Incoming Connections.

The screenshot shows the 'Channel Configuration' dialog box with the 'Channel 1' tab selected. The 'Driver' is set to 'Ethernet'. The 'Protocol Control' section contains several checkboxes: BOOTP Enable, DHCP Enable, SNMP Server Enable, SMTP Client Enable, HTTP Server Enable, DNP3 over IP Enable, Modbus TCP Enable, Disable EtherNet/IP Incoming Connections (highlighted with a red box), Auto Negotiate, and Disable Duplicate IP Address Detection. The 'Msg Connection Timeout (x 1mS)' is set to 15000, 'Msg Reply Timeout (x 1mS)' is 3000, and 'Inactivity Timeout (x Min)' is 30. The 'Port Setting' is '10/100 Mbps Full Duplex/Half Duplex'. There are also fields for 'Contact' and 'Location'.

2. Click Apply and OK.
3. Perform a power cycle in order for the changes to take effect.

The MicroLogix 1400 does not allow any incoming Ethernet/IP connections anymore. This means that you cannot use RSLogix 500/RSLogix Micro over Ethernet port to monitor or change the configuration/user program.

DNP3 Slave Application Layer

For more information about Ethernet Port Disable, see the MicroLogix 1400 Programmable Controllers Instruction Set Reference Manual, publication [1766-RM001](#).

This section covers DNP3 Slave Application Layer Function Codes and Internal Indications.

For details of Packet Formats for the request and response, refer to the DNP3 Protocol specifications.

Function Codes

FC_CONFIRM (FC Byte = 0x00)

00 - Confirm

A DNP3 master sends a message with this function code to confirm receipt of a response fragment. In a general environment, the MicroLogix 1400 receives a response with this function code. But the MicroLogix 1400 may generate a response with this function code when a DNP3 Master sends a request with the CON bit set in the application control header.

FC_READ (FC Byte = 0x01)

01 - Read

The READ function code is used by a DNP3 master to request data from the MicroLogix 1400.

FC_WRITE (FC Byte = 0x02)

02 - Write

The WRITE function code is used to write the contents of DNP3 objects from the DNP3 master to the MicroLogix 1400. This function code is used for clearing bit IIN1.7 [DEVICE_RESTART], setting time in the MicroLogix 1400 and downloading user programs to the MicroLogix 1400 controller.

FC_SELECT (FC Byte = 0x03)

03 - Select

The SELECT function code is used in conjunction with the OPERATE function code as part of select-before-operate method for issuing control requests. This procedure is used for controlling binary output (CROB) or analog output (AOB) objects.

FC_OPERATE (FC Byte = 0x04)

04 - Operate

See the comment for [FC_SELECT \(FC Byte = 0x03\) on page 284](#).

FC_DIRECT_OPERATE (FC Byte = 0x05)

05 - Direct Operate

This direct operate function is similar to the FC_OPERATE function code except that no preceding select command is required.

FC_DIRECT_OPERATE_NR (FC Byte = 0x06)

06 - Direct Operate No Resp

See the comment for FC_DIRECT_OPERATE. No response message is returned when this request is issued from a DNP3 master.

FC_IMMED_FREEZE (FC Byte = 0x07)

07 - Immediate Freeze

Upon receiving a request with this function, the MicroLogix 1400 copies the current value of a counter point to a separate memory location associated with the same point. The copied value remains constant until the next freeze operation to the same point.

FC_IMMED_FREEZE_NR (FC Byte = 0x08)

08 - Immediate Freeze No Resp

See the comment for FC_IMMED_FREEZE. No response message is returned when this request is issued from a DNP3 master..

FC_FREEZE_CLEAR (FC Byte = 0x09)

09 - Freeze and Clear

Upon receiving a request with this function, the MicroLogix 1400 copies the current value to the frozen value, then clears the current value to 0 immediately.

FC_FREEZE_CLEAR_NR (FC Byte = 0x0A)

10 - Freeze and Clear No Resp

See the comment for FC_FREEZE_CLEAR. No response message is returned when this request is issued from a DNP3 master.

FC_COLD_RESTART (FC Byte = 0x0D)

13 - Cold Restart

This function code forces the MicroLogix 1400 to perform a complete restart upon powering up.

FC_WARM_RESTART (FC Byte = 0x0E)

14 - Warm Restart

This function code forces the MicroLogix 1400 to perform a partial reset. This applies only to the MicroLogix 1400 Series B and Series C controller.

FC_INITIALIZE_APPL (FC Byte = 0x10)

16 - Initialize Application

This function code is used to initialize the user program which was downloaded by RSLogix 500/RSLogix Micro software.

FC_START_APPL (FC Byte = 0x11)

17 - Start Application

This function code is used to start the user program which was downloaded by RSLogix 500/RSLogix Micro software.

FC_STOP_APPL (FC Byte = 0x12)

18 - Stop Application

This function code is used to stop the user program which was downloaded by RSLogix 500/RSLogix Micro.

FC_ENABLE_UN SOLICITED (FC Byte = 0x14)

20 - Enable Unsolicited Message

This function is used to dynamically enable unsolicited messages generated in the MicroLogix 1400.

FC_DISABLE_UN SOLICITED (FC Byte = 0x15)

21 - Disable Unsolicited Message

This function is used to dynamically disable unsolicited messages generated in the MicroLogix 1400.

FC_DELAY_MEASURE (FC Byte = 0x17)

23 - Delay Measurement, used for Non-LAN Procedure

This function code is used to measure the communication channel delay time.

FC_RECORD_CURRENT_TIME (FC Byte = 0x18)

24 - Record Current Time, used for LAN Procedure

This function code is used in the procedure for time synchronizing MicroLogix 1400 controllers that communicate over a LAN.

This applies only to MicroLogix 1400 Series B and Series C controllers.

FC_OPEN_FILE (FC Byte = 0x19)

25 - Open File

This function code is used to make a file available for reading or writing.

FC_CLOSE_FILE (FC Byte = 0x1A)

26 - Close File

After the file reading or writing operation, this function code used to unlock the file.

FC_DELETE_FILE (FC Byte = 0x1B)

27 - Delete File

A DNP3 master uses this function code to delete a file.

FC_GET_FILE_INFO (FC Byte = 0x1C)

28 - Get File Information

This function code is for the master to retrieve information about a file in the MicroLogix 1400.

This applies only to MicroLogix 1400 Series B and Series C controllers.

FC_AUTHENTICATE_FILE (FC Byte = 0x1D)

29 - Authenticate File

This function code is used to obtain an authentication key that is needed to open or delete a file.

FC_ABORT_FILE (FC Byte = 0x1E)

30 - Abort File

This function code is used to immediately request termination of the current read/write operation and close the file, without saving.

This applies only to MicroLogix 1400 Series B and Series C controllers.

FC_ACTIVATE_CONFIG (FC Byte = 0x1F)

31 - Activate Config

This function code is used to begin using the configuration or executable code specified by the objects included in the request.

This applies only to MicroLogix 1400 Series B and Series C controllers.

FC_AUTHENTICATION_REQUEST (FC Byte = 0x20)

32 - Authentication Request

The master uses this function code when sending authentication messages to the MicroLogix 1400 that require a response

This applies only to MicroLogix 1400 Series B and Series C controllers.

FC_AUTHENTICATION_REQUEST_NR (FC Byte = 0x21)

33 - Authentication Request No Resp

This function code is used by the master to send authentication messages when no return response is required.

This applies only to MicroLogix 1400 Series B and Series C controllers.

FC_RESPONSE (FC Byte = 0x81)

129 - Response

All responses except for Unsolicited Response messages use this function code.

FC_UNSOLICITED_RESPONSE (FC Byte = 0x82)

130 - Unsolicited Response

Unsolicited Responses always use this function code regardless of which DNP3 objects are included.

FC_AUTHENTICATION_RESPONSE (FC Byte = 0x83)

131 - Authentication Response

This function code is used to issue authentication messages to the master. This applies only to MicroLogix 1400 Series B and Series C controllers.

Internal Indications

Internal Indication bits are set under the following conditions of the MicroLogix 1400 controllers:

- IIN1.0: ALL_STATIONS. This bit is set when an all-stations message is received.
- IIN1.1: CLASS_1_EVENTS. This bit is set when Class 1 event data is available.
- IIN1.2: CLASS_2_EVENTS. This bit is set when Class 2 event data is available.
- IIN1.3: CLASS_3_EVENTS. This bit is set when Class 3 event data is available.
- IIN1.4: NEED_TIME. This bit is set when Time synchronization is required.
- IIN1.5: LOCAL_CONTROL. This bit is set when the controller is in Non-Executing mode.
- IIN1.6: DEVICE_TROUBLE. This bit is set when the controller is in Fault mode.
- IIN1.7: DEVICE_RESTART. This bit is set when the DNP3 driver is just configured, in channel configuration or when the controller has been restarted.
To set this bit during the driver configuration and channel configuration, you need to select the "Send Init. Unsol. Null Resp. on Restart" setting and set Status Bit S:36/13 to 1 before downloading to the controller.
- IIN2.0: NO_FUNC_CODE_SUPPORT. This bit is set when a request which has an unknown function code is received.
- IIN2.1: OBJECT_UNKNOWN. This bit is set when a request which has an unknown object is received.
- IIN2.2: PARAMETER_ERROR. This bit is set when a request with a qualifier/range field that cannot be processed is received.
- IIN2.3: EVENT_BUFFER_OVERFLOW. This bit is set when an event buffer overflow condition exists in the controller and at least one unconfirmed event is lost.
- IIN2.4: ALREADY_EXECUTING. Not supported.

- IIN2.5: CONFIG_CORRUPT. This bit is set when a bad file type and bad file number are detected.
- IIN2.6: Reserved.
- IIN2.7: Reserved.

You can access the last transmitted IIN bits in the response through accessing the element of Communication Status file, CS0:58 or CS2:58. For more details, see Diagnostics.

DNP3 Objects and MicroLogix 1400 Data Files

All of the DNP3 Objects which are supported in the MicroLogix 1400 are summarized in [Implementation Table on page 371](#).

Data file types used in DNP3 Objects are not the same as that used in the MicroLogix controller, but are similar. Mapping is required between DNP3 data files and MicroLogix 1400 data files.

Overview

DNP3 Data objects that are implemented in the MicroLogix 1400 controller are listed below:

- DNP3 Binary Input Object
- DNP3 Double Bit Binary Input Object
- DNP3 Binary Output Object
- DNP3 Counter Object
- DNP3 Frozen Counter Object
- DNP3 Analog Input Object
- DNP3 Analog Output Object
- DNP3 BCD Object
- DNP3 Data Set Object (Series B and Series C controllers only)

Some of objects are divided into several Object files to map data files in the MicroLogix 1400 controller.

- Counter Object — 16bit and 32bit Counter Object File
- Analog Input Object — 16bit and 32bit Analog Input Object File, and Short Floating Point Analog Input Object File.
- Analog Output Object — 16bit and 32bit Analog Output Object File, and Short Floating Point Analog Output Object File.

For the MicroLogix 1400 Series A controllers:

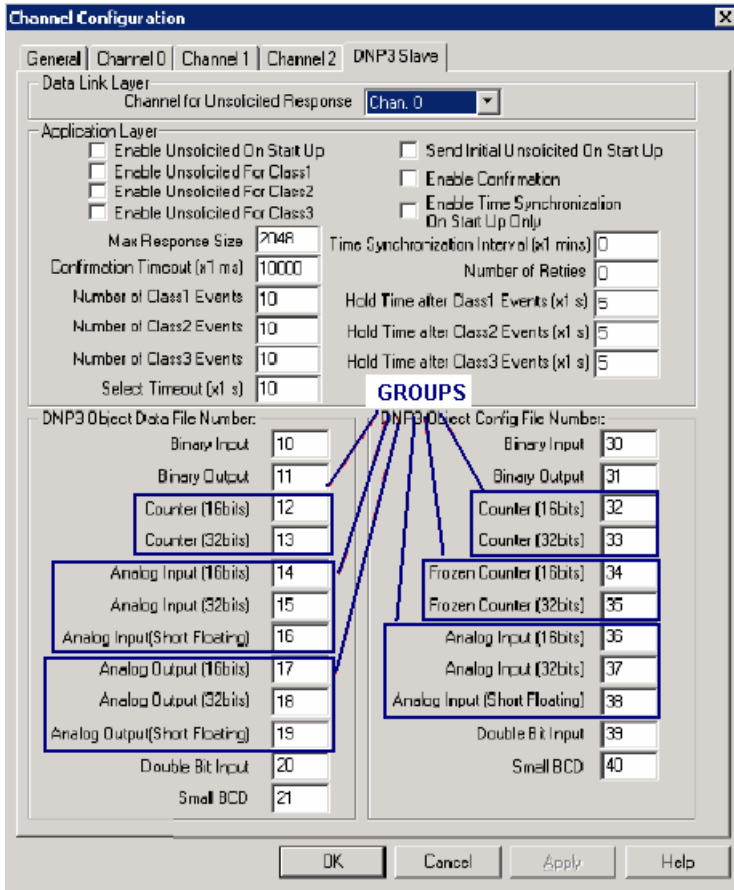

For the MicroLogix 1400 Series B and Series C controllers:

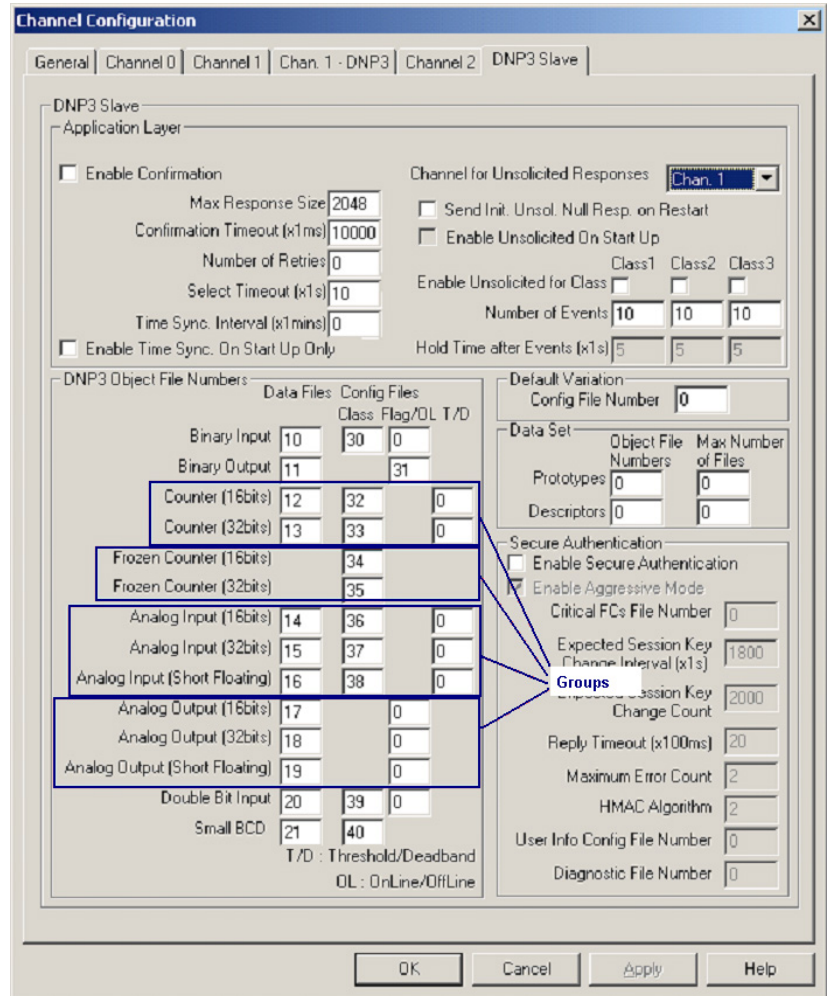

Each of the data files for a DNP3 Object will have a file number in the user memory as shown below. You can configure the Data file number for each DNP3 Object in the DNP3 Slave tab of the DNP3 Slave Application Layer Configuration. File types for this object file can be Binary, Integer, Long, or Float data files.

The file numbers for each DNP3 Object cannot be in conflict with each other.

DNP3 Data Files

Relationship between DNP3 object database and MicroLogix data files

DNP Objects			Micrologix Data Files			
Object Name	Related Groups	Maximum Configurable Index	File name for Data	File Type	File Number	Maximum Configurable Elements
Binary Input Object	1, 2	4096	Binary Input Object File	Only B file	3, 9 to 255	256
Double Bit Binary Input Object	3, 4	2048	Double Bit Binary Input Object File	Only B file	3, 9 to 255	256
Binary Output Object	10, 12	4096	Binary Input Object File	Only B file	3, 9 to 255	256
Counter Object	20, 22	256	16-bit Counter Object File	Only N file	7, 9 to 255	256
			32 bit Counter Object File	Only L file	9 to 255	
Frozen Counter Object	21, 23	reflection of Counter Object which was configured	reflection of 16-bit Counter Object File	-	-	-
			reflection of 32-bit Counter Object File			
Analog Input Object	30, 32	256	16-bit Analog Input Object File	Only N file	7, 9 to 255	256
			32-bit Analog Input Object File	Only L file	9 to 255	
			Short Floating Point Analog Input Object File	Only F file	8, 9 to 255	
Analog Output Object	40, 41	256	16-bit Analog Output Object File	Only N file	7, 9 to 255	256
			32-bit Analog Output Object File	Only L file	9 to 255	
			Short Floating Point Analog Output Object File	Only F file	8, 9 to 255	
BCD Object	101	256	Small BCD Object File	Only N file	7, 9 to 255	256
Data Set Object(In Series B and Series C)	85, 87, 88	10	Data Set Prototypes Object File	Only N file	7, 9 to 255	10
	86, 87, 88		Data Set Descriptors Object File			

Basically, the index number of DNP objects of each type is evaluated by the firmware automatically per the number of elements. For example, if a Binary Input object file was configured as an element, the highest index number of the Binary Input object is 15. The index number can only be increased by 16. If a Double-Bit Binary Input object file was configured as an element, the highest index number of the Double-Bit Binary Input object is 7. The index number can only be increased by 8.

As another example, if a 16-bit Analog Input object file was configured as an element, the highest index number is 1. Except for Binary and Double-Bit Binary type objects, the index number can be increased by 1.

DNP3 Configuration Files

You can set configuration files for each object. These configuration files allow you to configure parameters such as Class level and Object Flag bit information for each element. Only a Binary Data file type can be used for configuration file.

Relationship between MicroLogix Data Files and Configuration Files

MicroLogix Data Files	Configuration Files	File Type	File Number	Maximum Configurable Elements
Binary Input File	Binary Input Config File	Only B file	3, 9 to 255	256
	Binary Input Online Config File (In Series B and Series C)			
Double Bit Binary Input File	Double Bit Binary Input Config File	Only B file	3, 9 to 255	256
	Double-Bit Binary Input Online Config File (In Series B and Series C)			
Binary Output File	Binary Output Config File	Only B file	3, 9 to 255	256
16-bit Counter File	16-bit Counter Config File	Only B file	3, 9 to 255	256
	16-bit Counter Threshold Config File (In Series B and Series C)	Only N file	7, 9 to 255	
32-bit Counter File	32-bit Counter Config File	Only B file	3, 9 to 255	256
	32-bit Counter Threshold Config File (In Series B and Series C)	Only L file	9 to 255	
Frozen 16-bit Counter File	Frozen 16-bit Counter Config File	Only B file	3, 9 to 255	256
Frozen 32-bit Counter File	Frozen 32-bit Counter Config File	Only B file	3, 9 to 255	256
16-bit Analog Input File	16-bit Analog Input Config File	Only B file	3, 9 to 255	256
	16-bit Analog Input Deadband Config File (In Series B and Series C)	Only N file	7, 9 to 255	
32-bit Analog Input File	32-bit Analog Input Config File	Only B file	3, 9 to 255	256
	32-bit Analog Input Deadband Config File (In Series B and Series C)	Only L file	9 to 255	
Short Floating Point Analog Input File	Short Floating Point Analog Input Config File	Only B file	3, 9 to 255	256
	Short Floating Point Analog Input Deadband Config File (In Series B and Series C)	Only F file	8, 9 to 255	
16-bit Analog Output File	16-bit Analog Output Config File (In Series B and Series C)	Only B file	3, 9 to 255	256
32-bit Analog Output File	32-bit Analog Output Config File (In Series B and Series C)	Only B file	3, 9 to 255	256
Short Floating Point Analog Output File	Short Floating Point Analog Output Config File (In Series B and Series C)	Only B file	3, 9 to 255	256
Small BCD File	Small BCD Class Config File	Only B file	3, 9 to 255	256

For Binary Input, Double Bit Binary Input and Small BCD type data, you can configure Class information in the Configuration file. The lower 2 bits in the elements of the Configuration files are the configuration of Class information to the relative objects. Other bits are reserved.

Related Configuration Files:

- Binary Input Config File Number
- Double Bit Binary Input Config File Number

Class Information Configuration for Binary Input, Double Bit Binary Input, and Small BCD

Bit Offset	15	14	13	12	11	10	9	8	7	6	5	4	3	2	1	0
Element 0	r	r	r	r	r	r	r	r	r	r	r	r	r	r	C1	CO
Element 1	r	r	r	r	r	r	r	r	r	r	r	r	r	r	C1	CO
Element 2	r	r	r	r	r	r	r	r	r	r	r	r	r	r	C1	CO
Element 3	r	r	r	r	r	r	r	r	r	r	r	r	r	r	C1	CO
Element 4	r	r	r	r	r	r	r	r	r	r	r	r	r	r	C1	CO
Element 5	r	r	r	r	r	r	r	r	r	r	r	r	r	r	C1	CO
...																

r: reserved
 C1/CO: Class level, 0 to 3
 For Binary Input, Element_0 for data index 0 to 15
 For Double-Bit Binary Input, Element _0 for data index 0 to 7

For Binary Input and Binary Output type data, you can configure Online information of the object flag in the Configuration file. If this bit is set, the Online bit(bit 0) in the object flag for each point is set when you read Status type objects. You can set this information using ladder logic.

Related Configuration File:

- Binary Input Online Config File Number (In Series B and Series C)
- Binary Output Online Config File Number

Binary Input and Binary Output Type Configuration Data File

Bit Offset	15	14	13	12	11	10	9	8	7	6	5	4	3	2	1	0
Element 0	0	0	0	0	0	0	0	0	0	0	0	0	0	0	0	0
Element 1	0	0	0	0	0	0	0	0	0	0	0	0	0	0	0	0
Element 2	0	0	0	0	0	0	0	0	0	0	0	0	0	0	0	0
Element 3	0	0	0	0	0	0	0	0	0	0	0	0	0	0	0	0
Element 4	0	0	0	0	0	0	0	0	0	0	0	0	0	0	0	0
Element 5	0	0	0	0	0	0	0	0	0	0	0	0	0	0	0	0
...																

0: offline
 1: online
 For Binary Output, Element_0 for data index 0 to 15

For other Input type data, you can configure Class information and the object flag information in the Configuration file. The lower 2 bits in the elements of the Configuration files are the configuration of Class information to the relevant objects. The upper byte of the configuration file of these objects is used to configure the object flag. Other bits are reserved.

Two new bits are defined in MicroLogix 1400 Series B and Series C controllers. The bit TE is used to generate an event by setting it regardless of the change of

state. This bit can be used to generate the timed events. Once this bit is set by the ladder logic or communications, the MicroLogix 1400 clears it automatically after generating an event at the end of scan. The bit DCE is used to suppress the events by the change of state.

For example, if you want to trigger an event for an analog point every 15 minutes, you should set the TE bit every 15 minutes by the ladder logic. But, in this case, you may not want the state change events to be generated. Then, set the bit DCE. You can get the timed events every 15 minutes.

Related Configuration File Number:

- 16-bit Counter Config File Number
- 32-bit Counter Config File Number
- 16-bit Frozen Counter Config File Number
- 32-bit Frozen Counter Config File Number
- 16-bit Analog Input Config File Number
- 32-bit Analog Input Config File Number
- Short Floating Point Analog Input Config File Number

Class and Object Configuration for Other Input Data Type

Bit Offset	15	14	13	12	11	10	9	8	7	6	5	4	3	2	1	0
Element 0	F7	F6	F5	F4	F3	F2	F1	F0	r	r	DCE	TE	r	r	C1	C0
Element 1	F7	F6	F5	F4	F3	F2	F1	F0	r	r	DCE	TE	r	r	C1	C0
Element 2	F7	F6	F5	F4	F3	F2	F1	F0	r	r	DCE	TE	r	r	C1	C0
Element 3	F7	F6	F5	F4	F3	F2	F1	F0	r	r	DCE	TE	r	r	C1	C0
Element 4	F7	F6	F5	F4	F3	F2	F1	F0	r	r	DCE	TE	r	r	C1	C0
Element 5	F7	F6	F5	F4	F3	F2	F1	F0	r	r	DCE	TE	r	r	C1	C0
...																

r: reserved
 C1/C0: Class level, 0 to 3
 TE: Trigger Event for the point (In Series B and Series C)
 DCE: Disable Change of state Event for the point (In Series B and Series C)
 For other Inputs, Element_0 for data index 0
 F7-F0: Object Flags, FLAG7/FLAG6/FLAG5/LOCAL_FORCED/REMOTE_FORCED/COMM_LOST/RESTART/ONLINE

For Counter type data, you can configure Threshold information in the Configuration file. Each element can be configured to the threshold value for each point. A counter event is generated if the absolute value of the difference between the present value of a counter point and the value that was most recently queued as an event for that point exceeds the threshold value that was configured in this file.

Related Configuration File Numbers:

- 16-bit Counter Threshold Config File Number (In Series B and Series C)

- 32-bit Counter Threshold Config File Number (In Series B and Series C)

Word Offset	Description
Element 0	Threshold for point 0
Element 1	Threshold for point 1
Element 2	Threshold for point 2
Element 3	Threshold for point 3
Element 4	Threshold for point 4
Element 5	Threshold for point 5
...	

For Analog Input type data, you can configure Deadband information in the Configuration file. Each element can be configured to the deadband value for each point. An analog input event is generated if the absolute value of the difference between the present value of an analog input point and the value that was most recently queued as an event for that point exceeds the deadband value that was configured in this file.

Related Configuration File Numbers:

- 16-bit Analog Input Deadband Config File Number (In Series B and Series C)
- 32-bit Analog Input Deadband Config File Number (In Series B and Series C)
- Short Floating Point Analog Input Deadband Config File Number (In Series B and Series C)

Word Offset	Description
Element 0	Deadband for point 0
Element 1	Deadband for point 1
Element 2	Deadband for point 2
Element 3	Deadband for point 3
Element 4	Deadband for point 4
Element 5	Deadband for point 5
...	

For Analog Output type data, you can configure the object flag information in the Configuration file. The upper byte of the configuration file of these objects is used to configure the object flag. Other bits are reserved.

Related Configuration File Numbers:

- 16-bit Analog Input Deadband Config File Number (In Series B and Series C)
- 32-bit Analog Input Deadband Config File Number (In Series B and Series C)

- Short Floating Point Analog Input Deadband Config File Number (In Series B and Series C)

Analog Output Configuration Data File

Bit Offset	15	14	13	12	11	10	9	8	7	6	5	4	3	2	1	0
Element 0	F7	F6	F5	F4	F3	F2	F1	F0	r	r	r	r	r	r	r	r
Element 1	F7	F6	F5	F4	F3	F2	F1	F0	r	r	r	r	r	r	r	r
Element 2	F7	F6	F5	F4	F3	F2	F1	F0	r	r	r	r	r	r	r	r
Element 3	F7	F6	F5	F4	F3	F2	F1	F0	r	r	r	r	r	r	r	r
Element 4	F7	F6	F5	F4	F3	F2	F1	F0	r	r	r	r	r	r	r	r
Element 5	F7	F6	F5	F4	F3	F2	F1	F0	r	r	r	r	r	r	r	r
...																

r: reserved
 F7-F0: Object Flags, FLAG7/FLAG6/FLAG5/LOCAL_FORCED/REMOTE_FORCED/COMM_LOST/RESTART/ONLINE

For Small BCD type data, you can configure Class information in the Configuration file. The lower 2 bits in each element of the Configuration files are the configuration of Class information to the relevant objects. P0 bit in the first element is for excluding Small BCD Data from Class 0 poll responses. Other bits are reserved.

Related Configuration File Numbers:

- Small BCD Config File Number

Small BCD Configuration File Data

Bit Offset	15	14	13	12	11	10	9	8	7	6	5	4	3	2	1	0
Element 0	r	r	r	r	r	r	r	r	PO	r	r	r	r	r	C1	C0
Element 1	r	r	r	r	r	r	r	r	r	r	r	r	r	r	C1	C0
Element 2	r	r	r	r	r	r	r	r	r	r	r	r	r	r	C1	C0
Element 3	r	r	r	r	r	r	r	r	r	r	r	r	r	r	C1	C0
Element 4	r	r	r	r	r	r	r	r	r	r	r	r	r	r	C1	C0
Element 5	r	r	r	r	r	r	r	r	r	r	r	r	r	r	C1	C0
...															C1	C0

r: reserved
 C1/C0 : Class level, 0 to 3
 For Small BCD, Element_0 for data index 0
 PO: 0 for including Small BCD Data to Class 0 poll response

DNP3 Binary Input Object

The supported object group and variations are listed in this section. The MicroLogix 1400 responds with the default group and variation when the DNP3 Master requests to read the object with all variations.

Binary Input Static Objects:

- g1v0 - Binary Input - All Variations
- g1v1 - Binary Input - Packed format (default)
- g1v2 - Binary Input - With flags

Binary Input Event Objects:

- g2v0 - Binary Input Event - All Variations
- g2v1 - Binary Input Event - Without time
- g2v2 - Binary Input Event - With absolute time
- g2v3 - Binary Input Event - With relative time (default)

Related Object File Number:

- Binary Input Object File Number

Related Configuration File Number:

- Binary Input Config File Number

To generate a Binary Input Object from the DNP3 Subsystem in the controller, you should configure Binary Input Object File Number in the DNP3 Slave Application Layer Configuration file.

When the Binary Input Object File is configured, Index number starts from 0. 1 bit is used for 1 Index.

As an example, a Binary Input Object File is configured as shown below. This file has 10 elements and 160 Binary Input points. Index 0 of the Binary Input Object is B10:0/0, Index 1 is B10:0/1 and Index 159 is B10:9/15.

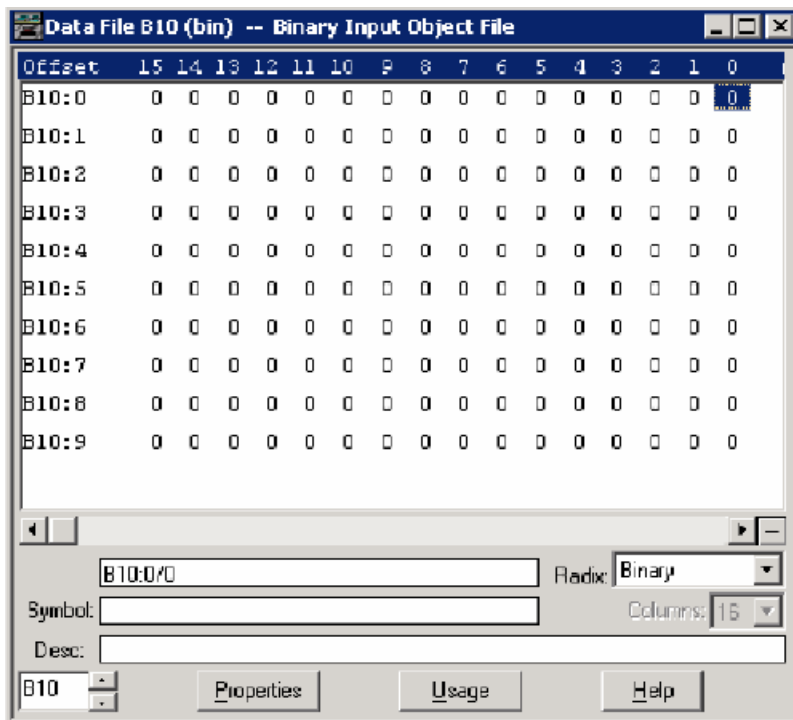

As an example, a Binary Input Config File shown below has 10 elements. B30:0/0 and B30:0/1 can be configured for Class Level 0, 1, 2 or 3 for DNP3 Index 0 to 15 of the Binary Input Object File. B30:1/0 and B30:1/1 can be configured for Class Level for DNP3 Index 16 to 31 of the Binary Input Object File. Default Class Level is 0. Any other bits are reserved.

Class Level of Index 0 to 15 is 1(B30:0/0 and B30:0/1), Class Level of Index 16 to 31 is 2(B30:1/0 and B30:1/1), Class Level of Index 32 to 47 is 3(B30:2/0 and B30:2/1), and Class Level of other Indexes are 0.

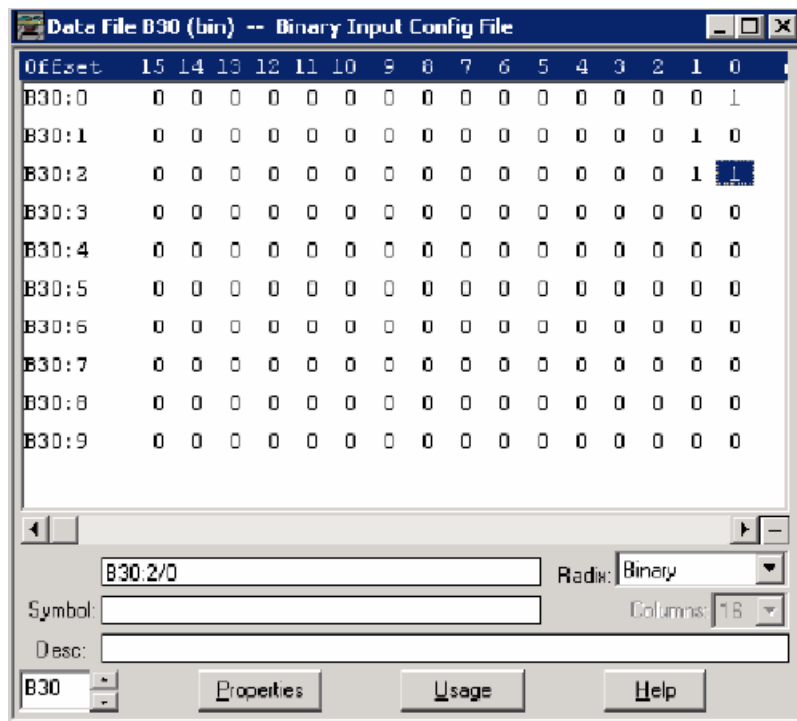

DNP3 Binary Output Object

The supported object group and variations are listed in this section. The MicroLogix 1400 responds with the default group and variation when the DNP3 Master requests to read the object with Any Variation.

Binary Output Static Objects:

- g10v0 - Binary Output - All Variations
- g10v2 - Binary Output - Output status with flags (default)

Binary Output Command Objects:

- g12v1 - Binary Command - Control relay output block (CROB)

Related Object File Number:

- Binary Output Object File Number

Related Configuration File Number:

- Binary Output Config File Number

To generate a Binary Output Object from the DNP3 Subsystem in the controller, you should configure Binary Output Object File Number in the DNP3 Slave Application Layer Configuration file.

When the Binary Output Object File is configured, Index number starts from 0. 1 bit is used for 1 Index.

As an example, a Binary Output Object File is configured as shown below. This file has 10 elements and 160 Binary Output points. Index 0 of the Binary Output Object is B11:0/0, Index 1 is B11:0/1 and Index 159 is B11:9/15.

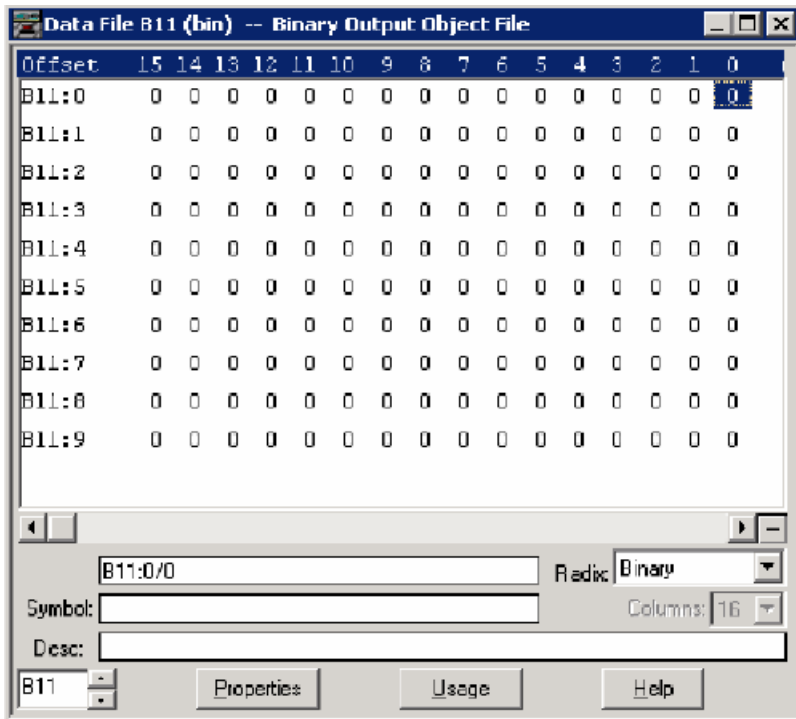

As an example, a Binary Output Config File shown below has 10 elements. Each bit can be configured for Online information (if the corresponding point is active or not, 0=offline, 1=online) of the Binary Output points. B31:0/0 is for Index 0, B31:0/1 is for Index 1 and B31:9/15 is for Index 159. In the example below, all bits are cleared and all of the points are in offline state.

If this bit is set, the Online bit in the status flag of each Binary Output points is set when you read Binary Output Status objects.

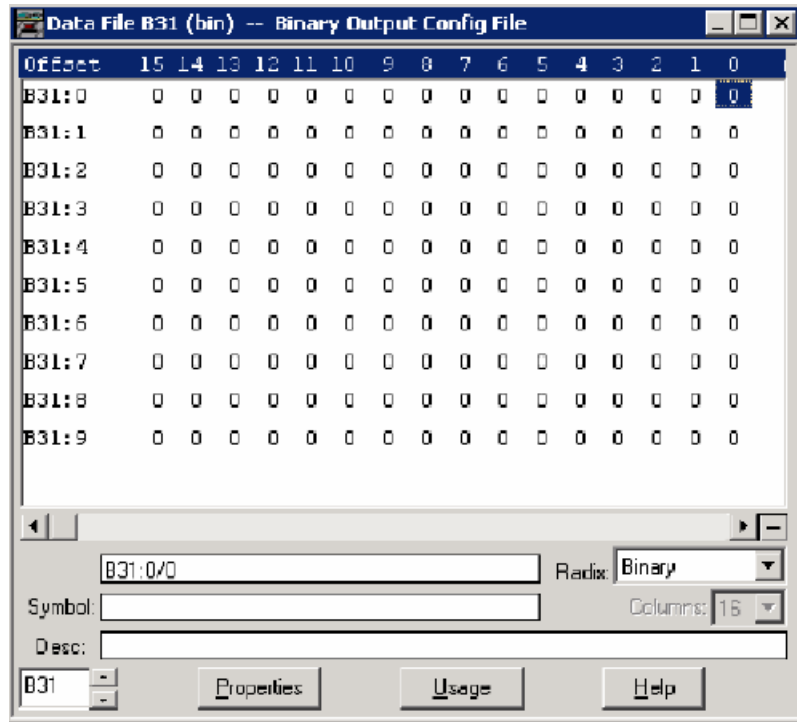

Binary Command - Control relay output block (CROB)

The MicroLogix 1400 has three control models for Binary Output Control. They are Activation model, Complementary latch model and Complementary two-output model.

For the Complementary two-output model, two bits are required to control this model in the Binary output object. The point index is different than in the Activation or Complementary latch model. The point index varies as shown in the table below. The maximum number of Binary Output index for Complementary two-output model is 2048.

Binary Output Database Index	Activation model or Complementary latch model	Complementary two-output model
0	BO Index 0	BO Close Index 0
1	BO Index 1	BO Trip Index 0
2	BO Index 2	BO Close Index 1
3	BO Index 3	BO Trip Index 1
4	BO Index 4	BO Close Index 2
5	BO Index 5	BO Trip Index 2
...
4094	BO Index 4094	BO Close Index 2047
4095	BO Index 4095	BO Trip Index 2047

These control codes and point models are implemented in the MicroLogix 1400 controller:

- 0x00 (NUL/NUL): Clear field Off
- 0x20 (NUL/NUL): Clear field On
- 0x01 (Pulse On/NUL): Clear field Off, Activation Model
- 0x21 (Pulse On/NUL): Clear field On, Activation Model
- 0x03 (Latch On/NUL): Clear field Off, Complementary latch model
- 0x23 (Latch On/NUL): Clear field On, Complementary latch model
- 0x04 (Latch Off/NUL): Clear field Off, Complementary latch model
- 0x24 (Latch Off/NUL): Clear field On, Complementary latch model
- 0x41 (Pulse On/Close): Clear field Off, Complementary two-output model
- 0x61 (Pulse On/Close): Clear field On, Complementary two-output model
- 0x81 (Pulse On/Trip): Clear field Off, Complementary two-output model
- 0xA1 (Pulse On/Trip): Clear field On, Complementary two-output model

When the MicroLogix 1400 is in Non-Executing mode, the controller will not accept a Binary Command. The MicroLogix 1400 returns a Control Status Code 7 in response. To access objects 12(CROB), the controller should be in Executing mode.

Note that Executing mode includes Run, Remote Run, Test Continuous Scan, and Test Single Scan modes. Any others are Non-Executing modes.

DNP3 Double Bit Binary Input Object

The supported object group and variations are listed in this section. The MicroLogix 1400 responds with the default group and variation when the DNP3 Master requests to read an object with Any variation.

Double-bit Binary Input Static Objects:

- g3v0 - Double-bit Binary Input - All Variations
- g3v1 - Double-bit Binary Input - Packed format (default)
- g3v2 - Double-bit Binary Input - With flags

Double-bit Binary Input Event Objects:

- g4v0 - Double-bit Binary Input Event - All Variations
- g4v1 - Double-bit Binary Input Event - Without time
- g4v2 - Double-bit Binary Input Event - With absolute time
- g4v3 - Double-bit Binary Input Event - With relative time (default)

Related Object File Number:

- Double Bit Binary Input Object File Number

Related Configuration File Number:

- Double Bit Binary Input Config File Number

To generate a Double Bit Binary Input Object from the DNP3 Subsystem in the controller, you should configure Double Bit Binary Input Object File Number in the DNP3 Slave Application Layer Configuration file.

When the Double Bit Binary Input Object File is configured, the Index number starts from 0.

2 bits are used for one Index.

As an example, a Double Bit Binary Input Object File is shown below. This file has 10 elements and 80 Double Bit Binary Input points. Index 0 of the Double Bit Binary Input Object is B20:0/0 and B20:0/1, Index 1 is B20:0/2 and B20:0/3, and Index 79 is B20:9/14 and B20:9/15.

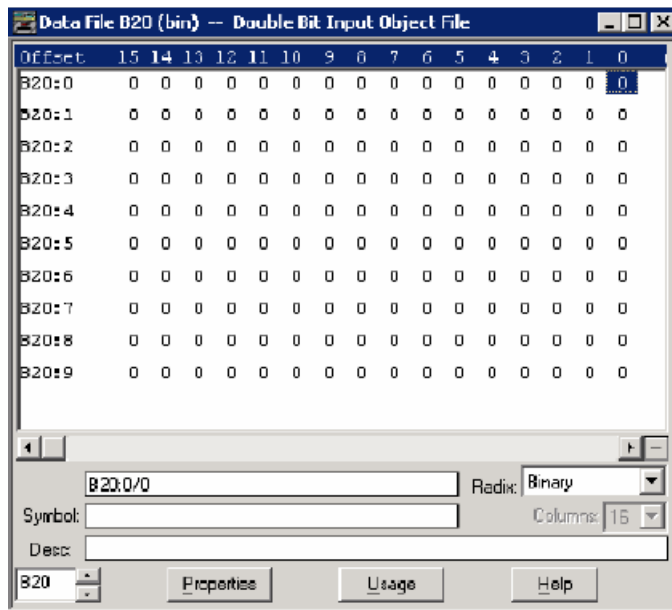

As an example, a Double Bit Binary Input Config File is shown below. This file has 10 elements. B39:0/0 and B39:0/1 can be configured for Class Level 0, 1, 2 or 3 for DNP3 Index 0 to 7 of the Double Bit Binary Input Object File. B39:1/0 and B39:1/1 can be configured for Class Level for DNP3 Index 8 to 15 of the Double Bit Binary Input Object File. Default Class Level is 0. Any other bits are reserved. So, in the example below, Class Level of Index 0 to 7 is 1(B39:0/0 and

B39:0/1), Class Level of Index 8 to 15 is 2(B39:1/0 and B39:1/1), Class Level of Index 16 to 23 is 3(B39:2/0 and B39:2/1), and Class Level of other Indexes are 0.

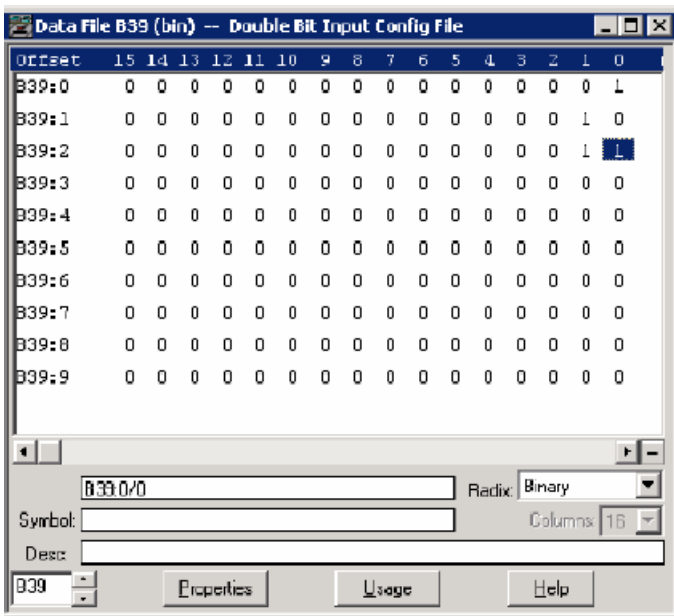

DNP3 Counter Object

The supported object group and variations are listed in this section. The MicroLogix 1400 responds with the default group and variation when the DNP3 Master requests to read an object with Any variation.

Counter Static Objects:

- g20v0 - Counter - Any Variation
- g20v1 - Counter - 32-bit with flag
- g20v2 - Counter - 16-bit with flag
- g20v5 - Counter - 32-bit without flag (default)
- g20v6 - Counter - 16-bit without flag (default)

Counter Event Objects:

- g22v0 - Counter Event - Any Variation
- g22v1 - Counter Event - 32-bit with flag (default)
- g22v2 - Counter Event - 16-bit with flag (default)

Related Object File Number:

- 16-bit Counter Object File Number
- 32-bit Counter Object File Number

Related Configuration File Number:

- 16-bit Counter Config File Number

- 32-bit Counter Config File Number

To generate a Counter Object from the DNP3 Subsystem in the controller, you should configure Counter Object File Numbers in the DNP3 Slave Application Layer Configuration file.

When only one Counter Object File is configured, the Index number starts from 0 for the configured object. One word is used for one Index of a 16-bit Counter Object and one double word is used for one Index of a 32-bit Counter Object.

If both the 16-bit Counter Object File Number and 32-bit Counter Object File Number were configured in the DNP3 Slave Application Layer Configuration file, the starting index number of 16-bit Counter Object is 0 and the starting index number of 32-bit Counter Object starts from the ending index number of the 16-bit Counter Object. For example, if 10 elements of a 16-bit Counter Object were configured and 10 elements of a 32-bit Counter Object were configured, the index number will be as below:

- 16-bit Counter Object: From 0 to 9
- 32-bit Counter Object: From 10 to 19

Let's suppose you configured both 16-bit and 32-bit Counter Object Files as below. Data File N12 has 10 elements and L13 has 10 elements accordingly. In total, 20 Counter Object indexes are configured. Index 0 of the Counter Object is N12:0, Index 1 is N12:1, Index 10 is L13:0 and Index 19 is L13:9.

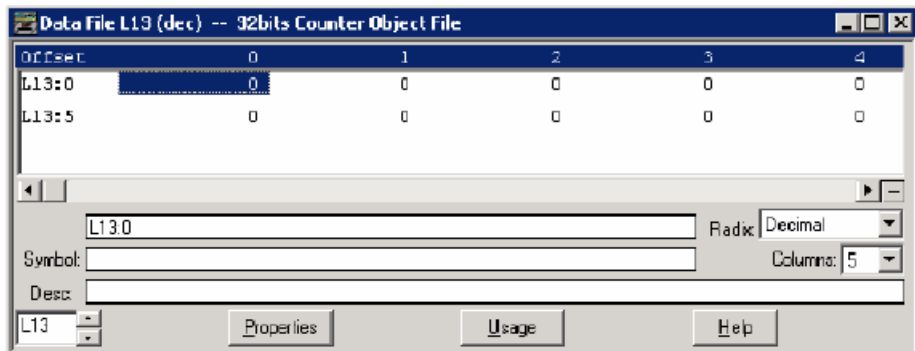
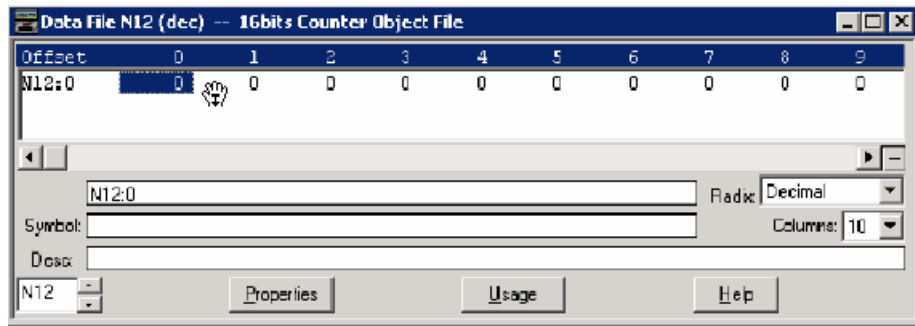

As an example, a Counter Config File is shown below. These files have 10 elements for each. B32:0/0 and B32:0/1 can be configured for Class Level 0, 1, 2 or 3 for DNP3 Index 0 of the 16 bits Counter Object File. B32:1/0 and B32:1/1

can be configured for Class Level for DNP3 Index 1 of the Counter Object File. Default Class Level is 0. Any other bits are reserved. So, in the example below, for 16-bit Counter Config File, Class Level of Index 0 is 1(B32:0/0 and B32:0/1), Class Level of Index 1 is 2(B32:1/0 and B32:1/1), Class Level of Index 2 is 3(B32:2/0 and B32:2/1), and Class Level of other Indexes are 0.

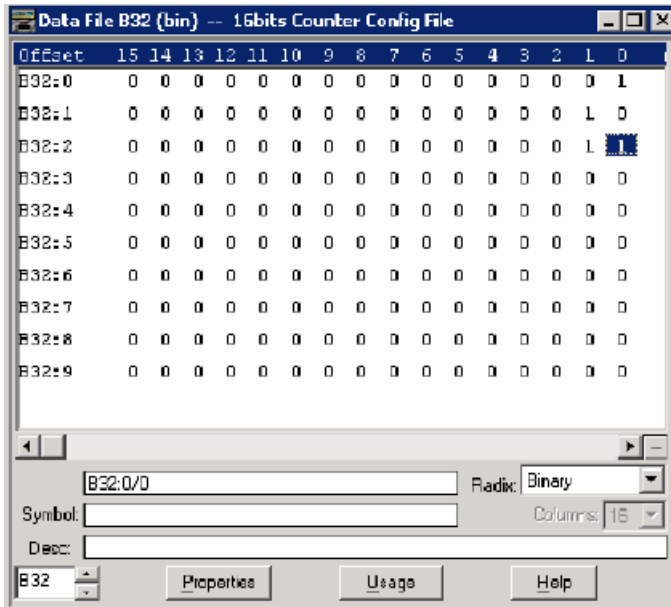

For a 32-bit Counter Config File, Class Level of Index 10 is 1(B33:0/0 and B33:0/1), Class Level of Index 11 is 2(B33:1/0 and B33:1/1), Class Level of Index 12 is 3(B33:2/0 and B33:2/1), and Class Level of other Indexes are 0.

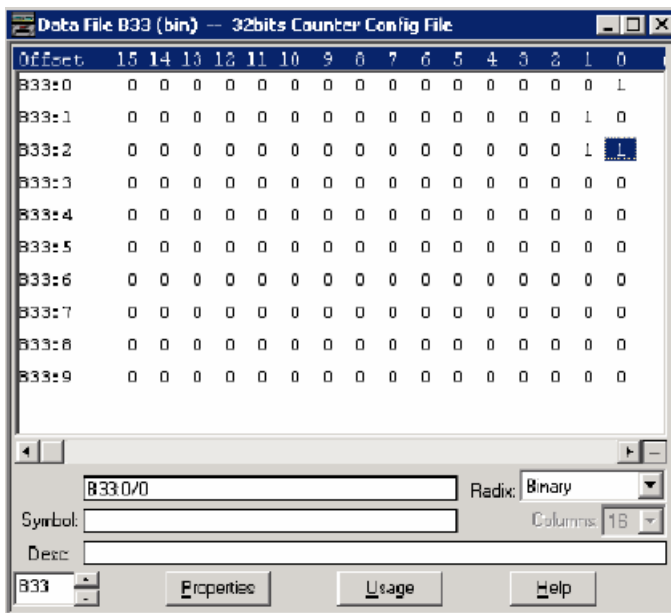

DNP3 Frozen Counter Object

The supported object group and variations are listed in this section. The MicroLogix 1400 responds with the default group and variation when the DNP3 Master requests to read the object with all variations.

Frozen Counter Static Objects:

- g21v0 - Frozen Counter - All Variations
- g21v1 - Frozen Counter - 32-bit with flag
- g21v2 - Frozen Counter - 16 bit with flag
- g21v5 - Frozen Counter - 32-bit with flag and time
- g21v6 - Frozen Counter - 16-bit with flag and time
- g21v9 - Frozen Counter - 32-bit without flag (default)
- g21v10 - Frozen Counter - 16-bit without flag (default)

Frozen Change Event Objects:

- g23v0 - Frozen Counter Event - All Variations
- g23v1 - Frozen Counter Event - 32-bit with flag (default)
- g23v2 - Frozen Counter Event - 16-bit with flag (default)
- g23v5 - Frozen Counter Event - 32-bit with flag and time
- g23v6 - Frozen Counter Event - 16-bit with flag and time

Related Object File Number:

- 16-bit Counter Object File Number
- 32-bit Counter Object File Number

Related Configuration File Number:

- 16-bit Frozen Counter Config File Number
- 32-bit Frozen Counter Config File Number

To generate a Frozen Counter Object from the DNP3 Subsystem in the controller, you should configure Counter Object File Number in the DNP3 Slave Application Layer Configuration file.

The number of elements for Frozen Counter Object is the same as the number of Counter Objects. For example, if 10 Counter elements were configured, 10 Frozen Counter elements will be generated in the MicroLogix 1400 controllers internally. You cannot access the Frozen Counter database directly.

There is one buffer for Frozen Counter Object. Read the Frozen Counter Object before you send another request with Freeze function codes. If two consecutive Freeze function codes are received without Read operation into them for Frozen Counter Object, the values of Frozen Counter Objects are overwritten by the second Freeze operation.

If both 16-bit Counter Object File Number and 32-bit Counter Object File Number were configured in the DNP3 Slave Application Layer Configuration file, the 16-bit Frozen Counter Object starting index number is 0 and the 32-bit Frozen Counter Object starting index number starts after the last index number for 16-bit Frozen Counter Object. For example, if 10 elements of 16-bit Counter Object were configured and 10 elements of 32-bit Counter Object were configured, the index numbers will be:

- 16-bit Frozen Counter Object: From 0 to 9
- 32-bit Frozen Counter Object: From 10 to 19

When only one of the Counter Object File was configured, Index number starts from 0 for the configured object.

As an example, a Frozen Counter Config File is shown below. These files have 10 elements for each. B34:0/0 and B34:0/1 can be configured for Class Level 0, 1, 2 or 3 for DNP3 Index 0 of the 16 bits Frozen Counter Object File. B34:1/0 and B34:1/1 can be configured for Class Level for DNP3 Index 1 of the Counter Object File. Default Class Level is 0. Any other bits are reserved. So, in the example below, for 16-bit Frozen Counter Config File, Class Level of Index 0 is 1 (B34:0/0 and B34:0/1), Class Level of Index 1 is 2 (B34:1/0 and B34:1/1), Class Level of Index 2 is 3 (B34:2/0 and B34:2/1), and Class Level of other Indexes are 0.

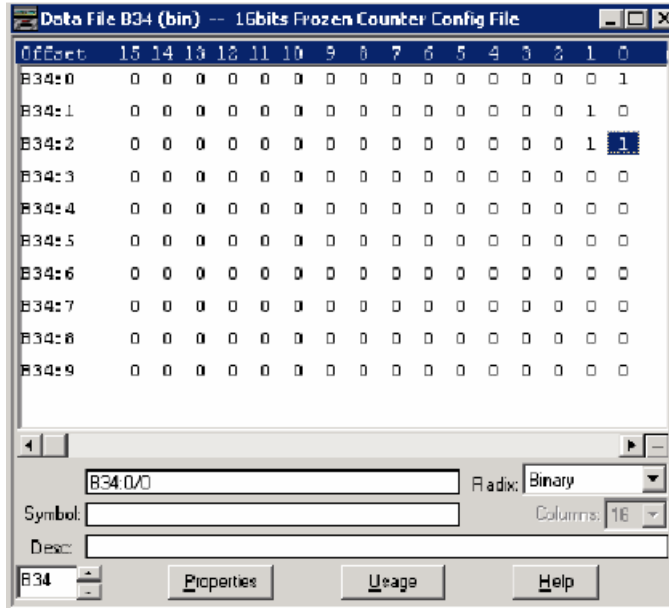

For 32-bit Frozen Counter Config File, Class Level of Index 10 is 1(B35:0/0 and B35:0/1), Class Level of Index 11 is 2(B35:1/0 and B35:1/1), Class Level of Index 12 is 3(B35:2/0 and B35:2/1), and Class Level of other Indexes are 0.

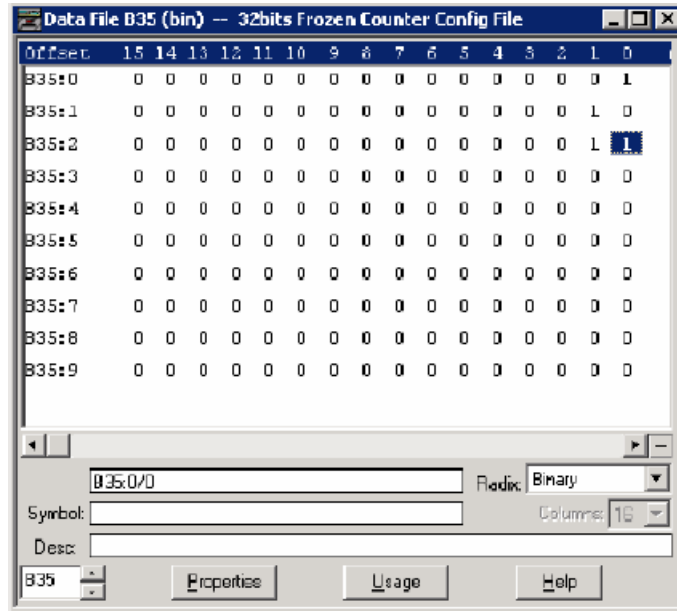

DNP3 Analog Input Object

The supported object group and variations are listed in this section. The MicroLogix 1400 responds with the default group and variation when the DNP3 Master requests to read the object with Any variation.

Analog Input Static Objects:

- g30v0 - Analog Input - Any Variations
- g30v1 - Analog Input - 32-bit with flag
- g30v2 - Analog Input - 16-bit with flag
- g30v3 - Analog Input - 32-bit without flag (default)
- g30v4 - Analog Input - 16-bit without flag (default)
- g30v5 - Analog Input - Single-prec flt-pt with flag (default)

Analog Input Event Objects:

- g32v0 - Analog Input Event - Any Variation
- g32v1 - Analog Input Event - 32-bit without time (default)
- g32v2 - Analog Input Event - 16-bit without time (default)
- g32v3 - Analog Input Event - 32-bit with time
- g32v4 - Analog Input Event - 16-bit with time
- g32v5 - Analog Input Event - Single-prec flt-pt without time (default)
- g32v7 - Analog Input Event - Single-prec flt-pt with time

Related Object File Number:

- 16-bit Analog Input Object File Number
- 32-bit Analog Input Object File Number
- Short Floating Point Analog Input Object File Number

Related Configuration File Number:

- 16-bit Analog Input Config File Number
- 32-bit Analog Input Config File Number
- Short Floating Point Analog Input Config File Number

To generate an Analog Input Object from the DNP3 Subsystem in the controller, you should configure Analog Input Object File Number in the DNP3 Slave Application Layer Configuration file.

When only one Analog Input Object File is configured, the Index number starts from 0 for the configured object. 1 word is used for 1 Index of 16-bit Analog Input Object, 1 double word is used for 1 Index of 32-bit Analog Input Object, and 1 short float is used for 1 Index of Short Floating Point Analog Input Object.

If 16-bit Analog Input Object File Number, 32-bit Analog Input Object File Number, and Short Floating Point Analog Input Object File Number were configured in the DNP3 Slave Application Layer Configuration file, the starting index number of 16-bit Analog Input Object is 0 and the starting index number of 32-bit Analog Input Object starts from the ending index number of 16-bit Analog Input Object.

For example, if 10 elements of 16-bit Analog Input Object were configured, 10 elements of 32-bit Analog Input Object, and 10 elements of Short Floating Point Analog Input Object were configured, the index numbers will be:

- 16-bit Analog Input Object: From 0 to 9
- 32-bit Analog Input Object: From 10 to 19
- Short Floating Point Analog Input Object: From 20 to 29

As an example, a configuration of 16-bit, 32-bit and Short Floating Point Analog Input Object Files is shown below. Data File N14 has 10 elements, L15 has 10 elements and F16 has 10 elements accordingly. A total of 30 Analog Input Object

indexes are configured. Index 0 of the Analog Input Object is N14:0, Index 10 is L15:0, Index 20 is F16:0 and Index 29 is F16:9.

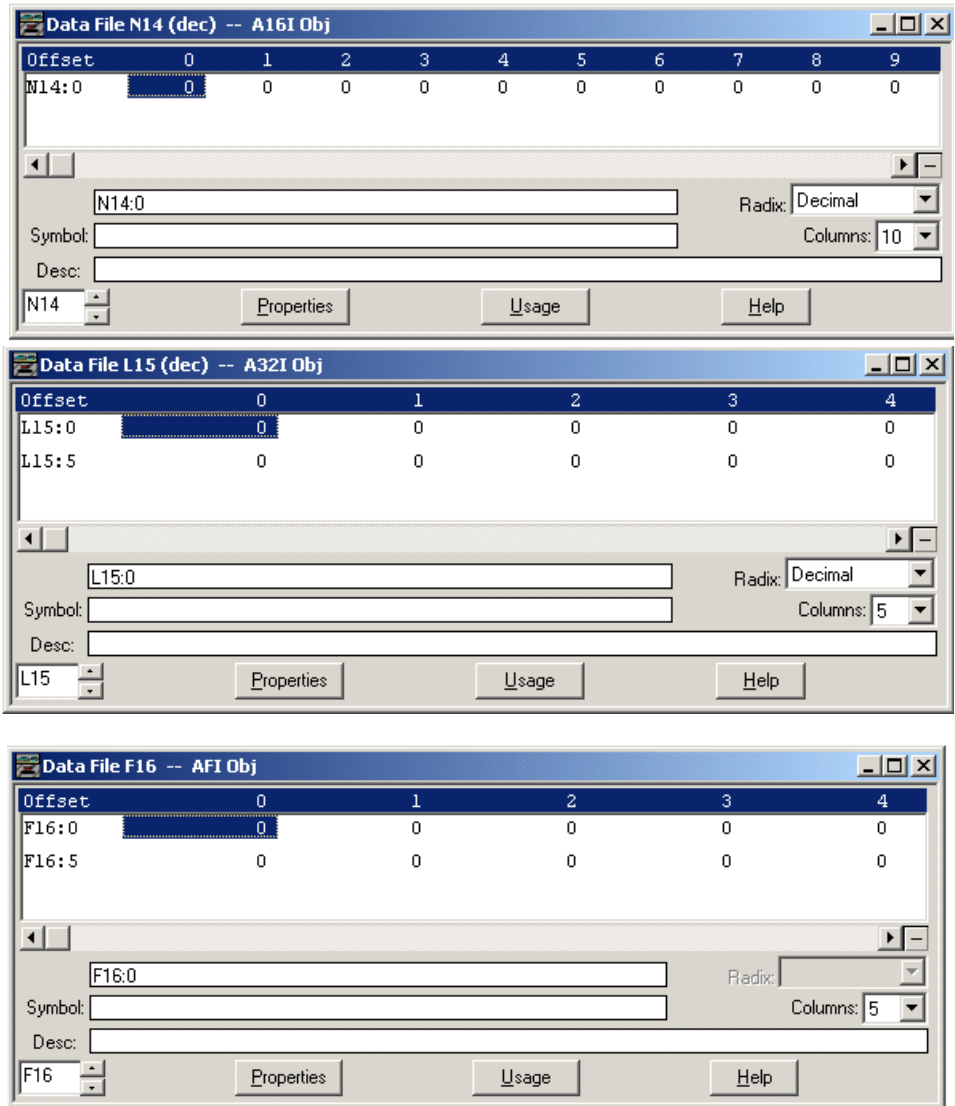

As an example, an Analog Input Config File is shown below. These files have 10 elements each.

B36:0/0 and B36:0/1 can be configured for Class Level 0, 1, 2 or 3 for DNP3 Index 0 of the 16 bits Analog Input Object File.
 B36:1/0 and B36:1/1 can be configured for Class Level for DNP3 Index 1 of the Analog Input Object File. Default Class Level is 0. Any other bits are reserved.
 In the example below, for 16-bit Analog Input Config File, Class Level of Index 0 is 1(B36:0/0 and B36:0/1), Class Level of Index 1 is 2(B36:1/0 and B36:1/1),

Class Level of Index 2 is 3(B36:2/0 and B36:2/1), and Class Level of other Indexes are 0.

Offset	15	14	13	12	11	10	9	8	7	6	5	4	3	2	1	0
B36:0	0	0	0	0	0	0	0	0	0	0	0	0	0	0	0	1
B36:1	0	0	0	0	0	0	0	0	0	0	0	0	0	0	1	0
B36:2	0	0	0	0	0	0	0	0	0	0	0	0	0	1	1	0
B36:3	0	0	0	0	0	0	0	0	0	0	0	0	0	0	0	0
B36:4	0	0	0	0	0	0	0	0	0	0	0	0	0	0	0	0
B36:5	0	0	0	0	0	0	0	0	0	0	0	0	0	0	0	0
B36:6	0	0	0	0	0	0	0	0	0	0	0	0	0	0	0	0
B36:7	0	0	0	0	0	0	0	0	0	0	0	0	0	0	0	0
B36:8	0	0	0	0	0	0	0	0	0	0	0	0	0	0	0	0
B36:9	0	0	0	0	0	0	0	0	0	0	0	0	0	0	0	0

For a 32-bit Analog Input Config File, Class Level of Index 10 is 1(B37:0/0 and B37:0/1), Class Level of Index 11 is 2(B37:1/0 and B37:1/1), Class Level of Index 12 is 3(B37:2/0 and B37:2/1), and Class Level of other Indexes are 0.

Offset	15	14	13	12	11	10	9	8	7	6	5	4	3	2	1	0
B37:0	0	0	0	0	0	0	0	0	0	0	0	0	0	0	0	1
B37:1	0	0	0	0	0	0	0	0	0	0	0	0	0	0	1	0
B37:2	0	0	0	0	0	0	0	0	0	0	0	0	0	1	1	0
B37:3	0	0	0	0	0	0	0	0	0	0	0	0	0	0	0	0
B37:4	0	0	0	0	0	0	0	0	0	0	0	0	0	0	0	0
B37:5	0	0	0	0	0	0	0	0	0	0	0	0	0	0	0	0
B37:6	0	0	0	0	0	0	0	0	0	0	0	0	0	0	0	0
B37:7	0	0	0	0	0	0	0	0	0	0	0	0	0	0	0	0
B37:8	0	0	0	0	0	0	0	0	0	0	0	0	0	0	0	0
B37:9	0	0	0	0	0	0	0	0	0	0	0	0	0	0	0	0

For Short Floating Point Analog Input Config File, Class Level of Index 20 is 1(B38:0/0 and B38:0/1), Class Level of Index 21 is 2(B38:1/0 and B38:1/1),

Class Level of Index 22 is 3(B38:2/0 and B38:2/1), and Class Level of other Indexes are 0.

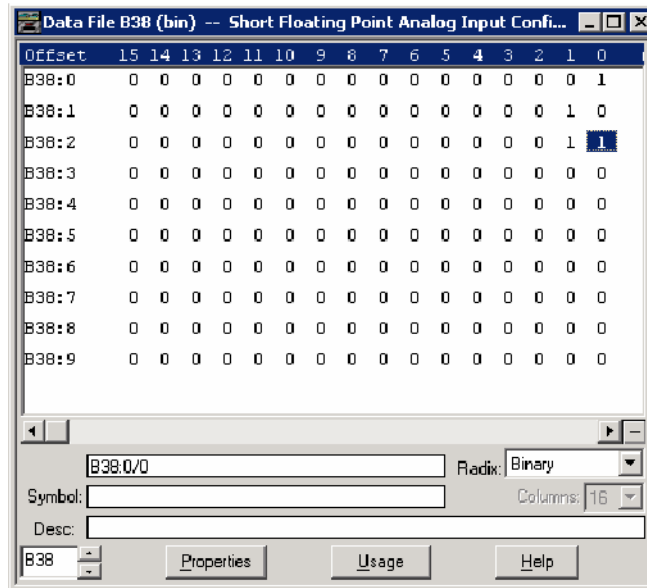

DNP3 Analog Output Object

The supported object group and variations are listed in this section. The MicroLogix 1400 responds with the default group and variation when the DNP3 Master requests to read an object with Any variation.

Analog Output Status Objects:

- g40v0 - Analog Output Status - Any Variations
- g40v1 - Analog Output Status - 32-bit with flag (default)
- g40v2 - Analog Output Status - 16-bit with flag (default)
- g40v3 - Analog Output Status - Single-prec flt-pt with flag (default)

Analog Output Command Objects:

- g41v1 - Analog Output - 32-bit
- g41v2 - Analog Output - 16-bit
- g41v3 - Analog Output - Single-prec flt-pt

Related Object File Number:

- 16-bit Analog Output Object File Number
- 32-bit Analog Output Object File Number
- Short Floating Point Analog Output Object File Number

Related Configuration File Number:

- None

To generate Analog Output Object from the DNP3 Subsystem in the controller, you should configure the Analog Output Object File Number in the DNP3 Slave Application Layer Configuration file.

When only one of the Analog Output Object File is configured, Index number starts from 0 for the configured object. 1 word is used for 1 Index of 16-bit Analog Output Object, 1 double word is used for 1 Index of 32-bit Analog Output Object, and 1 short float is used for 1 Index of Short Floating Point Analog Output Object.

If the 16-bit Analog Output Object File Number, 32-bit Analog Output Object File Number, and Short Floating Point Analog Output Object File Number are configured in the DNP3 Slave Application Layer Configuration file, the starting index number of 16-bit Analog Output Object is 0 and the starting index number of 32-bit Analog Output Object starts from the last index number of 16-bit Analog Output Object.

For example, if 10 elements of 16-bit Analog Output Object are configured, 10 elements of 32-bit Analog Output Object, and 10 elements of Short Floating Point Analog Output Object are configured, the index numbers will be:

- 16-bit Analog Output Object: From 0 to 9
- 32-bit Analog Output Object: From 10 to 19
- Short Floating Point Analog Output Object: From 20 to 29

As an example, 16-bit, 32-bit and Short Floating Point Analog Output Object Files are configured as below. Data File N17 has 10 elements, L18 has 10 elements and F19 has 10 elements accordingly. A total of 30 Analog Output Object index are configured. Index 0 of the Analog Output Object is N17:0, Index 10 is L18:0, Index 20 is F19:0 and Index 29 is F19:9.

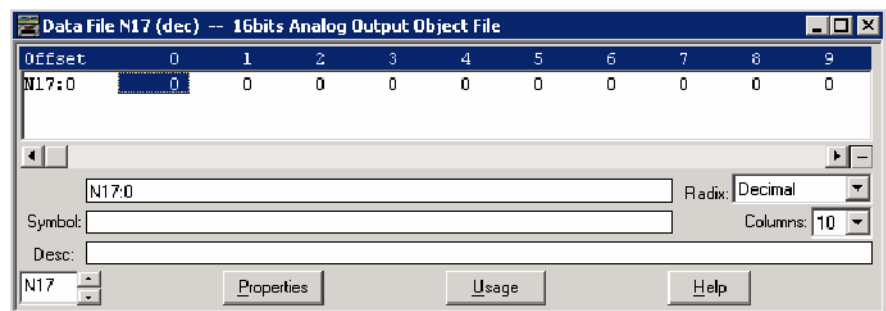

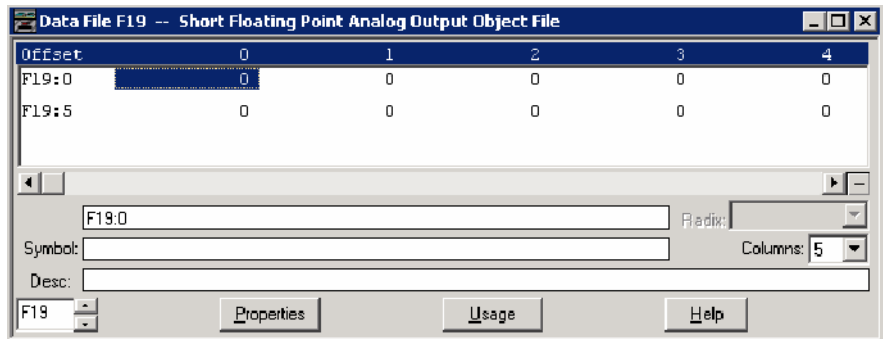
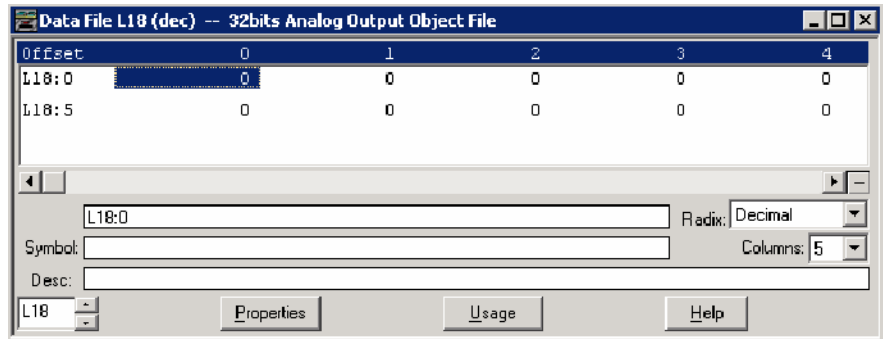

Analog Output Command - Control analog output block (AOB)

When the controller is in Non-Executing mode, the MicroLogix 1400 will not accept an Analog Output Command. The MicroLogix 1400 returns a Control Status Code 7 in the response. To access the objects 41(AOB), the controller mode should be in Executing mode.

Note that Executing mode includes Run, Remote Run, Test Continuous Scan, and Test Single Scan modes. Any other modes are Non-Executing modes.

DNP3 BCD Object

The supported object group and variations are as below.

Numeric Static Objects:

- g101v1 - Binary-Coded Decimal Integer - Small

Related Object File Number:

- Small BCD Object File Number

Related Configuration File Number:

- Small BCD Config File Number

To generate a Small BCD Object from the DNP3 Subsystem in the controller, you should configure the Small BCD Object File Number in the DNP3 Slave Application Layer Configuration file.

When a Small BCD Object File is configured, the Index number starts from 0. 1 word is used for 1 Index of Small BCD Object.

As an example, a Small BCD Object File is configured as shown below. Data File N21 has 10 elements. Index 0 of the Small BCD Object is N21:0, Index 1 is N21:1 and Index 9 is N21:9.

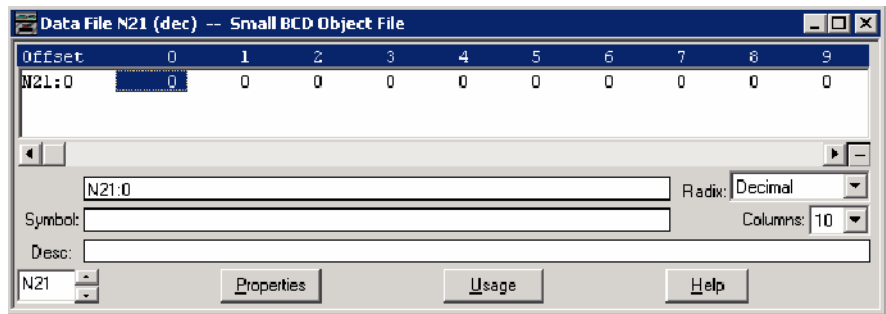

As an example, a Small BCD Config File is configured as shown below. The file has 10 elements. B40:0/0 and B40:0/1 can be configured for Class Level 0, 1, 2 or 3 for DNP3 Index 0 of the Small BCD Object File. B40:1/0 and B40:1/1 can be configured for Class Level for DNP3 Index 1 of the Small BCD Object File. Default Class Level is 0. Any other bits are reserved.

In the example below, for Small BCD Config File, Class Level of Index 0 is 1 (B40:0/0 and B40:0/1), Class Level of Index 1 is 2 (B40:1/0 and B40:1/1), Class Level of Index 2 is 3 (B40:2/0 and B40:2/1), and Class Level of other Indexes are 0.

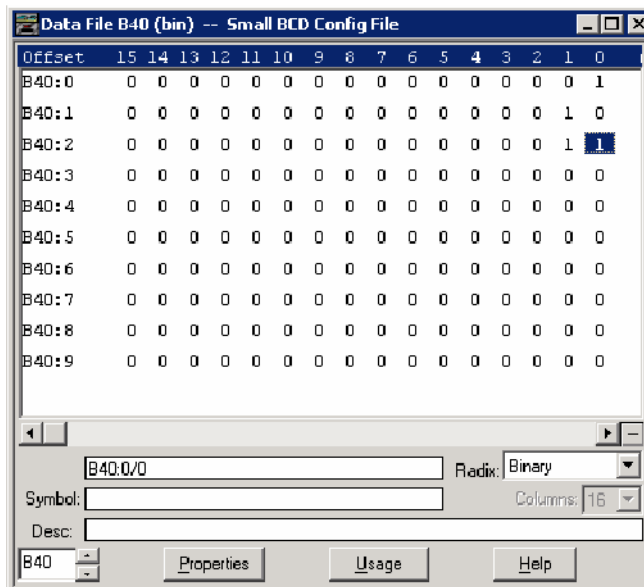

DNP3 Data Set Object

This feature is supported only in MicroLogix 1400 Series B and Series C controllers.

These object groups and variations are supported.

Data Set Objects:

- g85v0 - Data Set Prototype - Any Variation
- g85v1 - Data Set Prototype - With UUID
- g86v1 - Data Set Descriptor - Data set contents
- g86v2 - Data Set Descriptor - Characteristics
- g87v0 - Static Data Set - Any Variation
- g87v1 - Static Data Set - Present value
- g88v0 - Event Data Set - Any Variation
- g88v1 - Event Data Set - Snapshot

Related Object/Configuration File Number:

- Data Set Prototypes Object File Number
- Data Set Descriptors Object File Number

To generate a Data Set Object from the DNP3 Subsystem in the controller, configure Data Set Prototypes/Descriptors Object File Number in the DNP3 Slave Application Layer Configuration file and also the Maximum Number of Data Set Prototypes/Descriptors Files.

Each Data Set Prototypes Object file (N data file) can have up to 10 elements of Data Set Prototypes, and each Data Set Descriptors Object file (N data file) can have up to 10 elements of Data Set Descriptors.

As an example, with Data Set Prototypes files, if you configure "Data Set Prototypes Object File Numbers" to 50 and "Maximum Number of Data Set

Prototypes Files" to 9, N Data files 50 to 58 are reserved to store the structure of the Data Set Prototypes configuration.

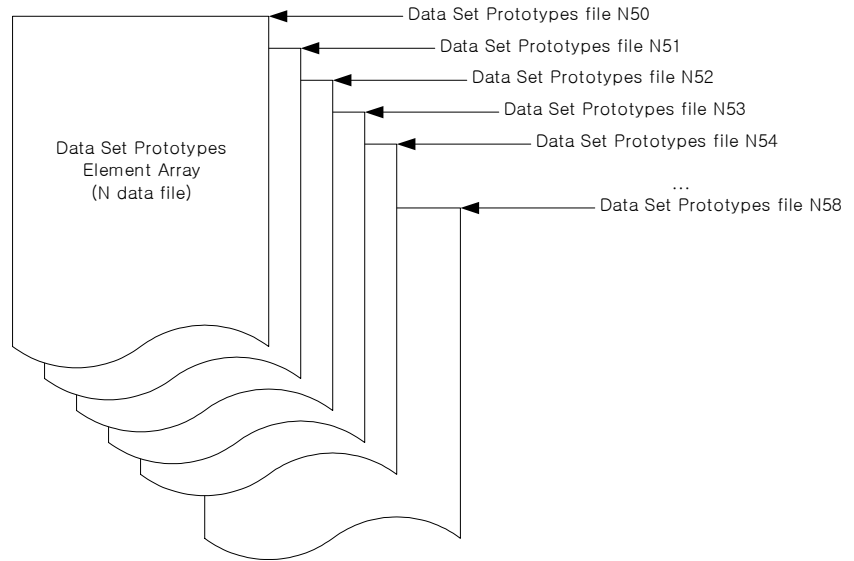

As an example, with Data Set Descriptors files, if you configure "Data Set Descriptors Object File Number" to 60 and "Maximum Number of Data Set Descriptors File" to 9, N Data files 60 to 68 are reserved to store the structure of the Data Set Descriptors configuration.

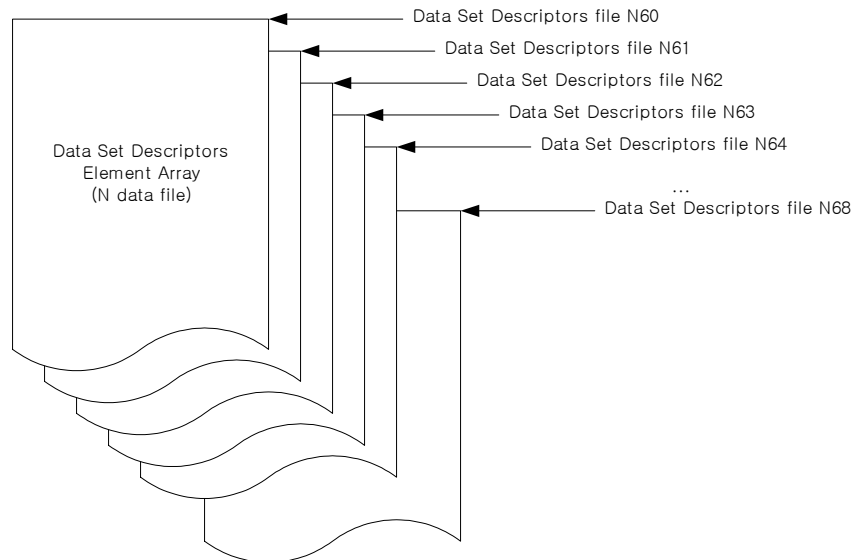

Once the Data Set Prototypes and Descriptors are configured in the DNP3 Slave Application Layer Configuration of RSLogix500/RSLogix Micro software, you can see the DNP3 DS Prototype X and DNP3 DS Descriptor X trees under the

Channel Configuration of RSLogix 500/RSLogix Micro software, where "X" is the element numbers of each Prototype or Descriptor.

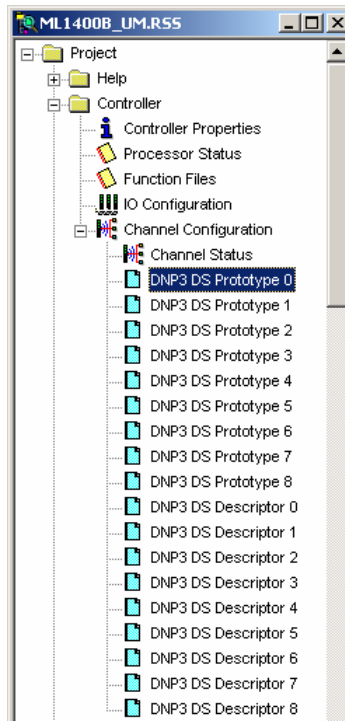

For DNP3 DS Prototype X, you can configure the MicroLogix 1400 to construct the Data Set Prototype objects.

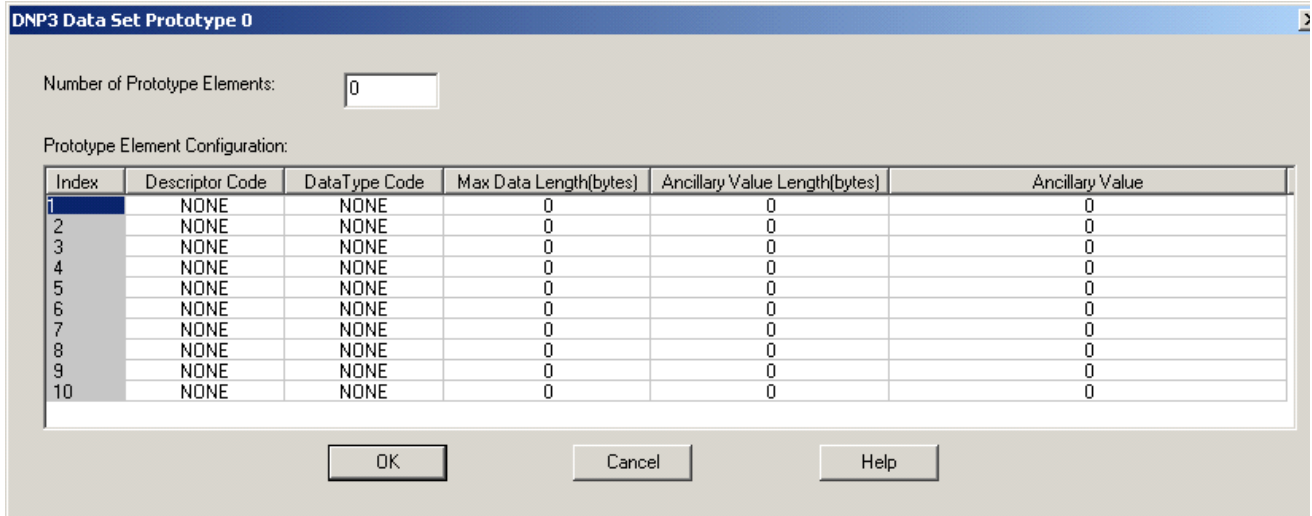

For DNP3 DS Descriptor X, you can configure the MicroLogix 1400 to construct the Data Set Descriptor objects.

DNP3 Data Set Descriptor 0

General

Number of Descriptor Elements: Event Occurrence Condition:

Characteristics:
 RD
 ST
 EV

Event Class:
 Event Class:
 Trigger Event Disable Change of State Event

Case	Point Address Type	PT/FN	PI	FE
0	Standard DNP3 Point	NONE	0	0
1	Standard DNP3 Point	NONE	0	0
2	Standard DNP3 Point	NONE	0	0
3	Standard DNP3 Point	NONE	0	0

PT : Point Type PI : Point Index
 FN : File Number FE : File Element FSE : File Sub Element

Descriptor Element Configuration:

Index	Descriptor Code	DataType Code	Max Data Length(bytes)	Ancillary Value Length(bytes)	Ancillary Value
1	NONE	NONE	0	0	0
2	NONE	NONE	0	0	0
3	NONE	NONE	0	0	0
4	NONE	NONE	0	0	0
5	NONE	NONE	0	0	0
6	NONE	NONE	0	0	0
7	NONE	NONE	0	0	0
8	NONE	NONE	0	0	0
9	NONE	NONE	0	0	0
10	NONE	NONE	0	0	0

OK Cancel

Data Set Prototypes Configuration Parameters

These parameters are used to construct Data Set Prototypes object.

DNP3 Data Set Prototype 0

Number of Prototype Elements:

Prototype Element Configuration:

Index	Descriptor Code	DataType Code	Max Data Length(bytes)	Ancillary Value Length(bytes)	Ancillary Value
1	NONE	NONE	0	0	0
2	NONE	NONE	0	0	0
3	NONE	NONE	0	0	0
4	NONE	NONE	0	0	0
5	NONE	NONE	0	0	0
6	NONE	NONE	0	0	0
7	NONE	NONE	0	0	0
8	NONE	NONE	0	0	0
9	NONE	NONE	0	0	0
10	NONE	NONE	0	0	0

OK Cancel Help

Number of Prototypes Elements: 0...10. This must be the same as the number of the Prototype elements that are configured.

Prototype Element Configuration: Each Prototypes element is configured in this configuration. Double-click an element to edit it.

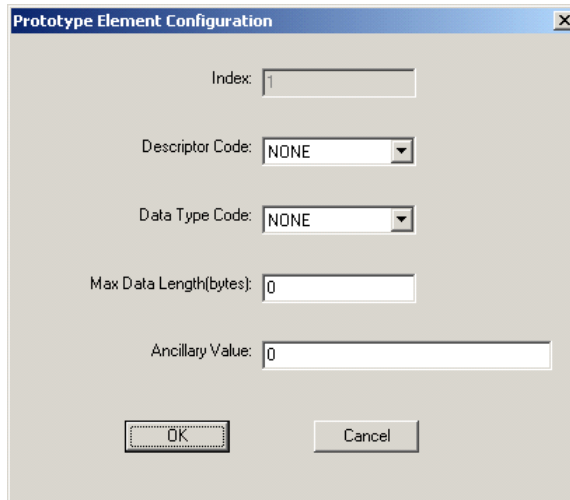

Descriptor Code: UUID for element 1. NSPC/NAME/DAEL for element 2 or higher.

Data Type Code: NONE for element 1.
NONE/VSTR/UINT/INT/FLT/OSTR/BSTR/TIME for element 2 or higher.

Max Data Length (bytes): 0 for element 1. 0...255 for element 2 or higher.

Ancillary Value: Binary Array in hexadecimal for element 1. ASCII strings for element 2 or higher. Maximum 32 bytes.

Data Set Descriptors Configuration Parameters

These parameters are used to construct Data Set Descriptors objects.

DNP3 Data Set Descriptor 0

General

Number of Descriptor Elements:

Event Occurrence Condition:

Case	Point Address Type	PT/FN	PI	FE
0	Standard DNP3 Point	NONE	0	0
1	Standard DNP3 Point	NONE	0	0
2	Standard DNP3 Point	NONE	0	0
3	Standard DNP3 Point	NONE	0	0

PT : Point Type PI : Point Index
FN : File Number FE : File Element FSE : File Sub Element

Characteristics

RD ST EV

Event Class

Event Class:

Trigger Event Disable Change of State Event

Descriptor Element Configuration:

Index	Descriptor Code	Data Type Code	Max Data Length(bytes)	Ancillary Value Length(bytes)	Ancillary Value
1	NONE	NONE	0	0	0
2	NONE	NONE	0	0	0
3	NONE	NONE	0	0	0
4	NONE	NONE	0	0	0
5	NONE	NONE	0	0	0
6	NONE	NONE	0	0	0
7	NONE	NONE	0	0	0
8	NONE	NONE	0	0	0
9	NONE	NONE	0	0	0
10	NONE	NONE	0	0	0

OK Cancel

Number of Descriptor Elements: 0...10. This must be the same as the number of the Descriptor elements that are configured.

Characteristics: Used to assign characteristics to this Descriptor.

- RD - set if data set is readable.
- ST - set if outstation maintains a static data set.
- EV - set if outstation generates a data set event.

Event Class - Used to assign Event Class to this Descriptor.

- 0 - None
- 1 - Class 1
- 2 - Class 2
- 3 - Class 3

Trigger Event: Set this parameter to generate an event unconditionally. This bit can also be set by the ladder logic to generate timed events. Once this parameter is set by the ladder logic or communications, the MicroLogix 1400 clears it automatically after generating an event at the end of scan. This parameter is stored as a bit in the relevant Data Set Descriptor Config file and the bit can be accessed by Nx:2/4 where x is the relevant Data Set Descriptor Config file number.

Disable Change of State Event: Setting this parameter suppresses the events generated by any Event Occurrence Condition.

Event Occurrence Condition: The conditions of Data Set Event for each Data Set Descriptor can be configured by Data Set Event Occurrence Condition 0/1/2/3 in the DNP3 Data Set Descriptors Object File. When one of the values that are pointing to the Event Occurrence Condition 0/1/2/3 are changed or the criteria are met, the MicroLogix 1400 generates a Data Set Event, retrievable using the object g88v1.

This table shows the supported conditions for Point Addressing. Double-click each case element to edit it.

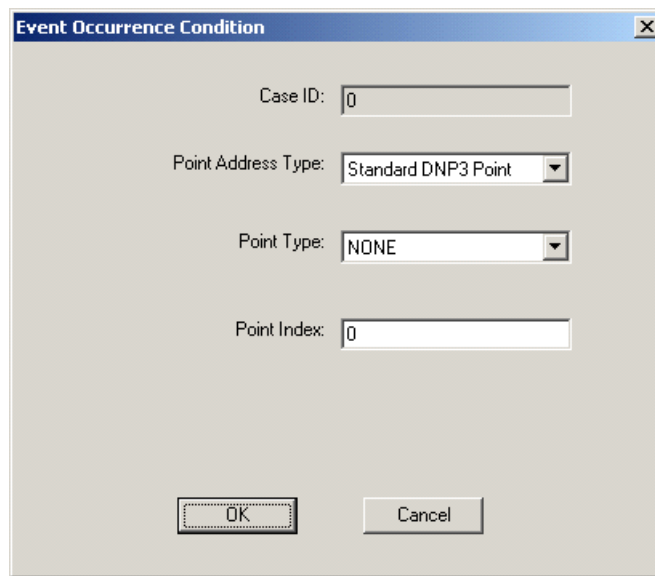

Point Addressing under Event Occurrence Conditions: Valid selections are shown below.

Point Address Type	Point Type	Point Index	Event Occurrence Condition
Standard DNP3 Point	NONE : No point type is associated.	0	No Event is generated.
	BI : Binary input	0 to 4095	When the Point Type and Point Index are pointing a specific point, if the value of the point is changed, an event is generated.
	B2I : Double-bit input	0 to 2047	
	CI : Counter	0 to 511	
	AI : Analog input	0 to 767	
	BCD : BCD point	0 to 255	
	Reserved for others.	Reserved for others.	No Event is generated.

Note that a Data Set event can consume any number of event buffers, depending on the Data Set configuration. This is only applicable to Data Set events. The event for other objects consumes a single event buffer. When using Data Set events, increase the number of events in the DNP3 Slave configuration.

Descriptor Element Configuration: Each Descriptors element is configured in this here. Double-click each element to edit it.

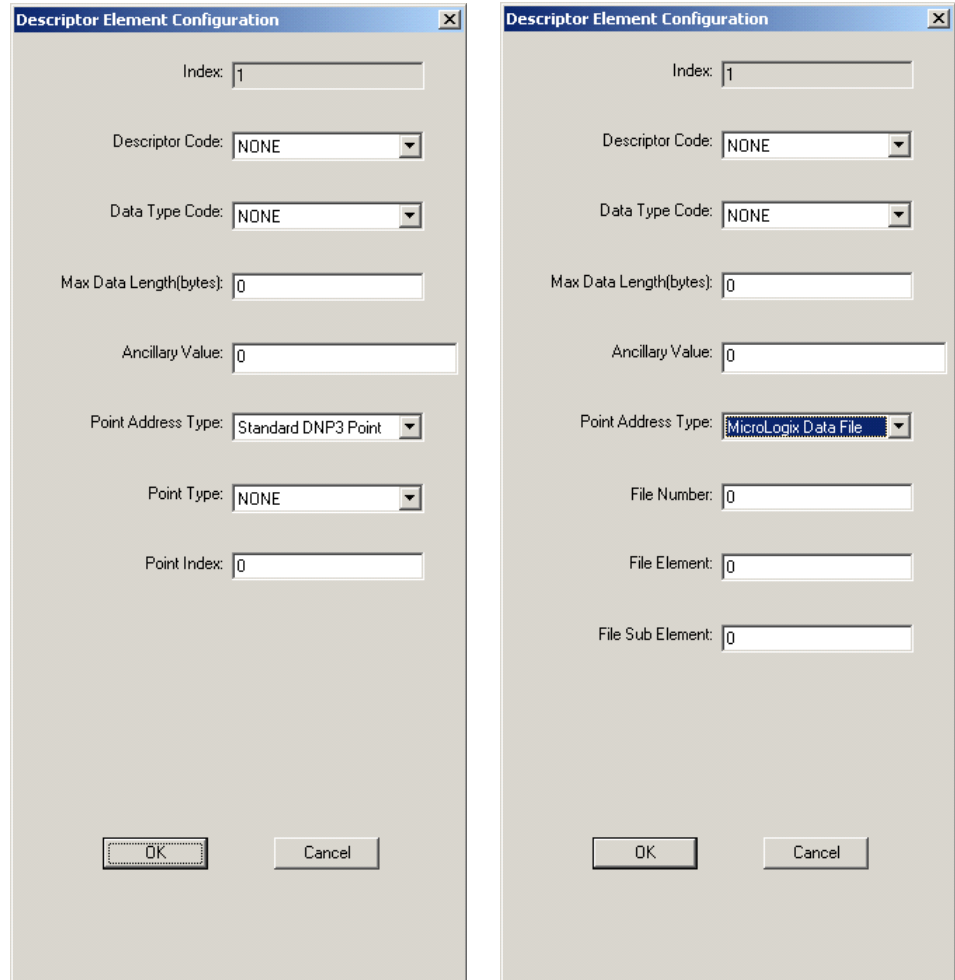

Descriptor Code: NONE, NAME, DAEL, PITYP

Data Type Code: NONE, VSTR, UINT, INT, FLT, OSTR, BSTR, TIME

Max Data Length (bytes): 0...255

Ancillary Value: Any string. This can be a binary array or ASCII string, up to 16 words.

Point Addressing under Descriptor Element Configuration: Data Set value for each Data Set element is configured by:

- Point Address Type
- Point Type
- Point Index

- File Number
- File Element
- File Sub Element.

When these values are configured properly according to the supported data files, the MicroLogix 1400 responds with a g87v1 object filled with the value in the data file. The following table shows the supported data files for the Point Addressing.

Table 2.2 Point Address Type — Standard DNP3 Point

Point Address Type	Data Type Code	Maximum Data Length (bytes)	Point Type	Point Index Low Byte	Point Index High Byte
Standard DNP3 Point	NONE = 0	0	NONE = 0: No point type is associated.	0	
	NONE = 0 UINT = 2 INT = 3 OSTR = 5 BSTR = 6 TIME = 7	0 0, 1, 2 or 4 0, 1, 2 or 4 0 to 255 0 to 255 0 or 6	BI = 1: Binary input	0 to Maximum 4095	When the Data Types other than OSTR and BSTR are used, the Point Index must be set to a point offset that is divisible by 16.
			B2I = 3: Double-bit input	0 to Maximum 2047	When the Data Types other than OSTR and BSTR are used, the Point Index must be set to a point offset that is divisible by 8.
			CI = 20: Counter	0 to Maximum 511	
			AI = 30: Analog input	0 to Maximum 767	
			BCD = 101: BCD point	0 to Maximum 255	

Table 2.3 Point Address Type — MicroLogix Data File

Point Address Type	Data Type Code	Maximum Data Length (bytes)	File Number	File Element	File Sub-Element
MicroLogix Data File	NONE = 0	0	0	0	0
	VSTR = 1	0...82	9...255 (ST)	9...255	0...40
	UINT = 2	0, 1, 2 or 4	2(S) 3, 9...255 (B) 7, 9...255 (N) 9...255 (L)	0...65 for S 0...255 for B, N, L	0 for S, N, L 0...15 for B
	INT = 3	0, 1, 2 or 4	2(S) 3, 9...255 (B) 7, 9...255 (N) 9...255 (L)	0...65 for S 0...255 for B, N, L	0 for S, N, L 0...15 for B
	FLT = 4	0 or 4	8, 9...255 (F)	0...255	0
	OSTR = 5	0...255	2(S) 3, 9...255 (B) 7, 9...255 (N)	0...65 for S 0...255 for B, N,	0 for S, N 0...15 for B
	BSTR = 6	0...255	2(S) 3, 9...255 (B) 7, 9...255 (N)	0...65 for S 0...255 for B, N,	0 for S, N 0...15 for B
TIME = 7	0...6	2(S) 3, 9...255 (B) 7, 9...255 (N) 9...255 (L)	0...65 for S 0...255 for B, N, L	0 for S, N, L 0...15 for B	

When the Descriptor Code is selected as PTYP, the Point Addressing parameters for the Descriptor element are replaced by 10 Point Addressing parameters. These should be configured in the same order of the DAEL elements in the relevant Prototypes.

The screenshot shows the 'Descriptor Element Configuration' dialog box. On the left, there are fields for:

- Index: 1
- Descriptor Code: PTYP
- Data Type Code: NONE
- Max Data Length(bytes): 0
- Ancillary Value: 00000000000000000000000000000000

 The main area contains 10 sub-panels, each for a Point Address (1 through 10). Each sub-panel includes:

- Point Address Type: Standard DNP3 Point
- Point Type: NONE
- Point Index: 0

 At the bottom left, there are 'OK' and 'Cancel' buttons.

For instance, if Prototype 0 includes a Namespace at Index 2 and Name at Index 3, then the first DAEL in the Prototype 0 is at Index 4. The Prototype DAEL at Index 4 matches Point Address 4 in the PTYP element configuration. Because of

this, Point Address 4 in the PTYP element configuration of the Descriptor should be configured properly.

DNP3 Data Set Prototype 0

Number of Prototype Elements:

Prototype Element Configuration:

Index	Descriptor C...	Data Type Code	Max Data Length(...)	Ancillary Value Leng...	Ancillary Value
1	UUID	NONE	0	16	????????????????????????????????
2	NSPC	NONE	0	16	Application Name
3	NAME	NONE	0	10	Fault Name
4	DAEL	UINT	2	27	Fault Code in System Status
5	NONE	NONE	0	0	0
6	NONE	NONE	0	0	0
7	NONE	NONE	0	0	0
8	NONE	NONE	0	0	0
9	NONE	NONE	0	0	0
10	NONE	NONE	0	0	0

OK Cancel Help

Descriptor Element Configuration

Index:

Descriptor Code:

Data Type Code:

Max Data Length(bytes):

Ancillary Value:

Point Address 1

Point Address Type:

Point Type:

Point Index:

Point Address 2

Point Address Type:

Point Type:

Point Index:

Point Address 3

Point Address Type:

Point Type:

Point Index:

Point Address 4

Point Address Type:

File Number:

File Element:

File Sub Element:

Point Address 5

Point Address Type:

Point Type:

Point Index:

OK Cancel

DAEL configuration for relevant Prototype 0 Index 4

Object Quality Flags

The object flag is composed of an 8 bit string for some DNP3 objects. The tables below show Flag Descriptions for each object. The ONLINE, RESTART, COMM_LOST, REMOTE_FORCED and LOCAL_FORCED flags are common to all object group types that contain flags.

There are some rules for the Object flag set or clear for each bit by the controller. The rules below are also applied to Event data.

- When the controller is in Non-Executing mode, the object flag is always all 0.
- When the controller is in Executing mode and there is no configuration file, only the Online flag in the object flag is set.
- When the controller is in Executing mode and there is a configuration file, the flags in the object flag are set according to the upper byte of the configuration files.

Object Flags for Binary Input

Bit Offset	Name	Description
0	ONLINE	In Series A controllers: 0 when the controller is or was in Non-Executing mode. 1 when the controller is or was in Executing mode. In Series B and Series C controllers: 0 when the controller is or was in Non-Executing mode. 1 when the controller is or was in Executing mode and the configuration file does not exist. May be 1 when the controller is or was in Executing mode and the configuration file exists.
1	RESTART	Always 0. Not used.
2	COMM_LOST	Always 0. Not used.
3	REMOTE_FORCED	Always 0. Not used.
4	LOCAL_FORCED	Always 0. Not used.
5	CHATTER_FILTER	Always 0. Not used.
6	reserved	Always 0. Not used.
7	STATE	Reflects point state of Binary Input point.

Object Flags for Double Binary Input

Bit Offset	Name	Description
0	ONLINE	In Series A controllers: 0 when the controller is or was in Non-Executing mode. 1 when the controller is or was in Executing mode. In Series B and Series C controllers: 0 when the controller is or was in Non-Executing mode. 1 when the controller is or was in Executing mode and the configuration file does not exist. May be 1 when the controller is or was in Executing mode and the configuration file exists.
1	RESTART	Always 0. Not used.
2	COMM_LOST	Always 0. Not used.
3	REMOTE_FORCED	Always 0. Not used.
4	LOCAL_FORCED	Always 0. Not used.
5	CHATTER_FILTER	Always 0. Not used.
6	STATE	Reflects point state of Double-Bit Binary Input point. Double-bit LSB.
7	STATE	Reflects point state of Double-Bit Binary Input point. Double-bit MSB

Object Flags for Binary Output

Bit Offset	Name	Description
0	ONLINE	0 when the controller is or was in Non-Executing mode. 1 when the controller is or was in Executing mode and the configuration file does not exist. May be 1 when the controller is in Executing mode and the configuration file exists.
1	RESTART	Always 0. Not used.
2	COMM_LOST	Always 0. Not used.
3	REMOTE_FORCED	Always 0. Not used.
4	LOCAL_FORCED	Always 0. Not used.
5	reserved	Always 0. Not used.
6	reserved	Always 0. Not used.
7	STATE	Reflects point state of Binary Output point.

Object Flags for Counter

Bit Offset	Name	Description
0	ONLINE	0 when the controller is or was in Non-Executing mode. 1 when the controller is or was in Executing mode and the configuration file does not exist. May be 1 when the controller is in Executing mode and the configuration file exists.
1	RESTART	0 when the controller is or was in Non-Executing mode.
2	COMM_LOST	0 when the controller is or was in Executing mode and the configuration file does not exist.
3	REMOTE_FORCED	May be 1 when the controller is in Executing mode and the configuration file exists.
4	LOCAL_FORCED	
5	ROLLOVER	
6	DISCONTINUITY	
7	reserved	

Object Flags for Analog Input

Bit Offset	Name	Description
0	ONLINE	0 when the controller is or was in Non-Executing mode. 1 when the controller is or was in Executing mode and the configuration file does not exist. May be 1 when the controller is in Executing mode and the configuration file exists.
1	RESTART	0 when the controller is or was in Non-Executing mode.
2	COMM_LOST	0 when the controller is or was in Executing mode and the configuration file does not exist.
3	REMOTE_FORCED	May be 1 when the controller is in Executing mode and the configuration file exists.
4	LOCAL_FORCED	
5	OVER_RANGE	
6	REFERENCE_ERR	
7	reserved	

Object Flags for Analog Output

Bit Offset	Name	Description
0	ONLINE	0 when the controller is or was in Non-Executing mode. 1 when the controller is or was in Executing mode.
1	RESTART	Always 0. Not used.
2	COMM_LOST	Always 0. Not used.
3	REMOTE_FORCED	Always 0. Not used.
4	LOCAL_FORCED	Always 0. Not used.
5	reserved	Always 0. Not used.
6	reserved	Always 0. Not used.
7	reserved	Always 0. Not used.

Object Flags for Analog Output for Series A controllers

Bit Offset	Name	Description
0	ONLINE	0 when the controller is or was in Non-Executing mode. 1 when the controller is or was in Executing mode.
1	RESTART	Always 0. Not used.
2	COMM_LOST	Always 0. Not used.
3	REMOTE_FORCED	Always 0. Not used.
4	LOCAL_FORCED	Always 0. Not used.
5	reserved	Always 0. Not used.
6	reserved	Always 0. Not used.
7	reserved	Always 0. Not used.

Object Flags for Analog Output for Series B and Series C controllers

Bit Offset	Name	Description
0	ONLINE	0 when the controller is or was in Non-Executing mode. 1 when the controller is or was in Executing mode and the configuration file does not exist. May be 1 when the controller is in Executing mode and the configuration file exists.
1	RESTART	0 when the controller is or was in Non-Executing mode.
2	COMM_LOST	0 when the controller is or was in Executing mode and the configuration file does not exist.
3	REMOTE_FORCED	May be 1 when the controller is in Executing mode and the configuration file exists.
4	LOCAL_FORCED	
5	reserved	
6	reserved	
7	reserved	

DNP3 Device Attribute Object

The Device Attribute object can be used to identify DNP3 Slave devices. With the MicroLogix 1400, some of the variations are written so that you can read or write your own strings in your application.

The object group of the Device Attribute object is 0. The supported range of the variation is 211...255.

The R/W property shows if the object is Read Only, Read, or Write. If the R/W property is writable, the value which was written by DNP3 master device is stored to non-volatile memory.

The object group of the Device Attribute is 0. The supported range of the variation is 211...255.

Object Group 0, Variations for Attribute Set 0

Variation	Read /Write	Attribute Data Type	Length in Bytes (Series A)	Max Length in Bytes (Series B and Series C)	Description	Value (Series A)	Value (Series B)
211	Read Only	VSTR	27	0 for DNP3	Identifier of support for user-specific attributes	Returns the identifier for user-specific attributes. "Rockwell Automation, Inc., 1"	Returns the identifier for user-specific attributes. "", NULL for DNP3.
212	Read Only	UINT	4	2	Number of master-defined data set prototypes	0	0
213	Read Only	UINT	4	2	Number of outstation-defined data set prototypes	0	The configured number in the DNP3 Slave Application Layer Configuration file. 10, max
214	Read Only	UINT	4	2	Number of master-defined data sets	0	0
215	Read Only	UINT	4	2	Number of outstation-defined data sets	0	The configured number in the DNP3 Slave Application Layer Configuration file. 10, max
216	Read Only	UINT	4	2	Max number of binary outputs per request	10	10
217	Read Only	UINT	4	2	Local timing accuracy	10,000 in microseconds	
218	Read Only	UINT	4	2	Duration of timing accuracy	0 in seconds	
219	Read Only	INT	1	1	Support for analog output events	0	0
220	Read Only	UINT	4	2	Max analog output index	256*3	
221	Read Only	UINT	4	2	Number of analog outputs	0...256*3	
222	Read Only	INT	1	1	Support for binary output events	0	
223	Read Only	UINT	4	2	Max binary output index	256*16	
224	Read Only	UINT	4	2	Number of binary outputs	0...256*16	
225	Read Only	INT	1	1	Support for frozen counter events	1	

Object Group 0, Variations for Attribute Set 0

Variation	Read /Write	Attribute Data Type	Length in Bytes (Series A)	Max Length in Bytes (Series B and Series C)	Description	Value (Series A)	Value (Series B)
226	Read Only	INT	1	1	Support for frozen counters	1	
227	Read Only	INT	1	1	Support for counter events	1	
228	Read Only	UINT	4	2	Max counter index	256*2	
229	Read Only	UINT	4	2	Number of counter points	0...256*2	
230	Read Only	INT	1	1	Support for frozen analog inputs	0	
231	Read Only	INT	1	1	Support for analog input events	1	
232	Read Only	UINT	4	2	Maximum analog input index	256*3	
233	Read Only	UINT	4	2	Number of analog input points	0...256*3	
234	Read Only	INT	1	1	Support for double-bit binary input events	1	
235	Read Only	UINT	4	2	Maximum double-bit binary input index	256*8	
236	Read Only	UINT	4	2	Number of double-bit binary input points	0...256*8	
237	Read Only	INT	1	1	Support for binary input events	1	
238	Read Only	UINT	4	2	Max binary input index	256*16	
239	Read Only	UINT	4	2	Number of binary input points	0...256*16	
240	Read Only	UINT	4	2	Max transmit fragment size	2048 (27...2048). When this value is written to the controller, the communication configuration file is changed to this value.	
241	Read Only	UINT	4	2	Max receive fragment size	2048	
242	Read Only	VSTR	length of the string value	length of the string value	Device manufacturer's software version	This variation returns firmware FRN. "FRN 1.00". Supported ranges: "FRN x.yy", "FRN x.yyy", "FRN xx.yy" or "FRN xx.yyy" where x, xx is 0 ~ 99 and yy, yyy 00 ~ 999. For example, "FRN 1.00", "FRN 1.05", "FRN 12.05", "FRN 102.27" or "FRN 103.117".	
243	Read Only	VSTR	length of the string value	length of the string value	Device manufacturer's hardware version	This variation returns hardware series and revision of the controller. "HW SER A/REV 01". Supported ranges: "HW SER x/REV yy" where x is A ~ F and yy is 00 ~ 31. For example, "HW SER A/REV 01", "HW SER B/REV 03", or "HW SER C/REV 31".	This variation returns hardware series and revision of the controller. "HW SER A/REV 03".
244	-	-	-	-	Reserved for future assignment	-	-

Object Group 0, Variations for Attribute Set 0

Variation	Read /Write	Attribute Data Type	Length in Bytes (Series A)	Max Length in Bytes (Series B and Series C)	Description	Value (Series A)	Value (Series B)
245	Read /Write	VSTR	length of the string value, max 255 bytes	length of the string value, max 255 bytes	User-assigned location name	"". Non-NULL terminated.	
246	Read /Write	VSTR	length of the string value, max 255 bytes	length of the string value, max 255 bytes	User-assigned ID code/number	"". Non-NULL terminated.	
247	Read /Write	VSTR	length of the string value, max 255 bytes	length of the string value, max 255 bytes	User-assigned device name	"". Non-NULL terminated.	
248	Read Only	VSTR	12	12	Device serial number	This variation returns Ethernet MAC ID. "0000BCxxxxx".	
249	Read Only	VSTR	6	6	DNP subset and conformance	This variation returns Subset level and Test procedure version. "2:2008".	This variation returns Subset level and Test procedure version. "2:2009".
250	Read Only	VSTR	length of the string value	length of the string value	Device manufacturer's product name and model	This variation returns Catalog Number and OS Series of the controller. "1766-L32BWA SER A".	This variation returns Catalog Number and OS Series of the controller. "1766-L32BWA SER B".
						Supported ranges: "1766-L32xxxa SER y" where xxxa is BWA, AWA, BXB, BWAA, AWAA, or BXBA and y is A ~ F. For example, "1766-L32BWA SER A", "1766-L32AWA SER B", "1766-L32BxB SER C", or "1766-L32BWAA SER A".	
251	-	-	-	-	Reserved for future assignment	-	-
252	Read Only	VSTR	13	19	Device manufacturer's name	This variation returns the Company name. "Allen-Bradley".	This variation returns the Company name. "Rockwell Automation" for DNP3.
253	Read Only	-	-	-	Reserved for future assignment	-	-
254	Read Only	-	-	-	Non-specific all attributes request	This variable returns all of the variations in this group except this variation.	
255	Read Only	-	-	-	List of attribute variations	This variation returns the R/W property for each variation. From g0v211 to g0v253. 0 for Read Only 1 for Read or Write	

Event Reporting

This section covers how to generate DNP3 events from DNP3 Data Objects and how to report the generated events by polled response or unsolicited response.

Generating Events

The MicroLogix 1400 has a separate buffer area that you can use to log DNP3 events internally.

The maximum number of the Events that can be logged is 6013 or 10000 (see [DNP3 10K Event Logging on page 338](#)), regardless of the Event data type. With Series B and Series C controllers, a Data Set event can consume multiple numbers of the event buffers.

If the number of the generated events reaches this value, the MicroLogix 1400 sets IIN2.3 [EVENT_BUFFER_OVERFLOW]. Further events are not logged until the logged events are reported to DNP3 Master and the buffer is available.

The elements CS0:67 or CS2:67 in the Communication status file show how many events are logged to the event buffer. The logged events are not removed until they are reported to DNP3 Master successfully. Logged event can also be cleared when one of the following events occur:

- New OS firmware upgrade
- New user program download.

The example below shows how to generate events for a Binary Input Object and a 16-bit Analog Input Object. In the DNP3 Slave configuration, Binary Input Object Data File Number was configured to 10 and its Configuration File Number was configured to 30. 16-bit Analog Input Object Data File Number was configured to 14 and its Configuration File Number was configured to 36.

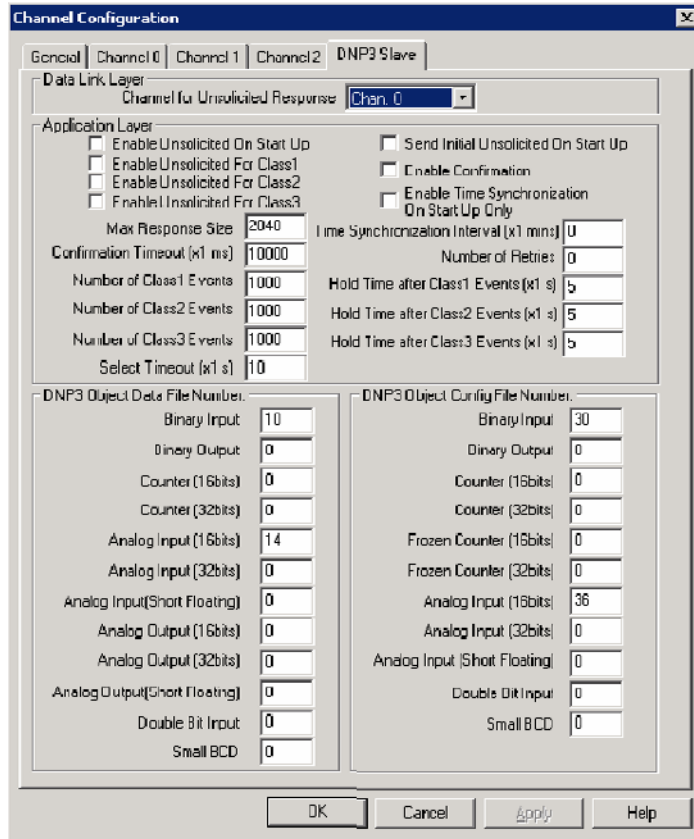

4 files will be automatically generated in the tree list of the Data Files.

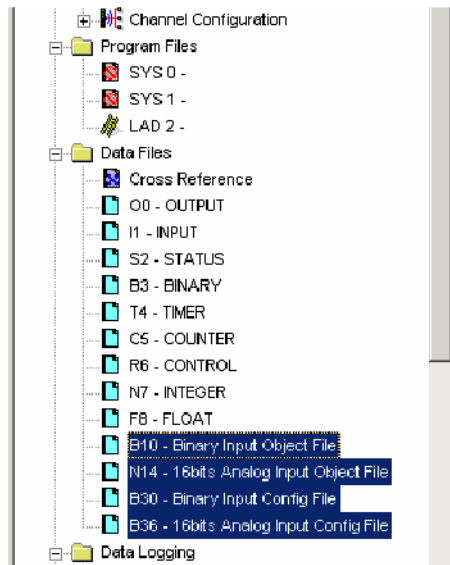

You need to adjust the number of the elements for each file according to your application. In this example, the number of the elements is 10 for Binary Input Object File and 10 for 16-bit Analog Input Object File.

In the Binary Input Config File, the bit 1/bit 0 of B30:0, B30:1 and B30:2 are configured to 0/1, 1/0 and 1/1 respectively. The event for the index 0 - 15 of Binary Input Object will be generated as a Class 1 event, the event for the index 16 - 31, as a Class 2 event and the event for the index 32 - 47, as a Class 3 event, if there are any changes for the points(B10:0, B10:1 or B10:2). For any other Binary Input points, the events will not be generated.

Offset	15	14	13	12	11	10	9	8	7	6	5	4	3	2	1	0
B30:0	0	0	0	0	0	0	0	0	0	0	0	0	0	0	0	1
B30:1	0	0	0	0	0	0	0	0	0	0	0	0	0	0	1	0
B30:2	0	0	0	0	0	0	0	0	0	0	0	0	0	0	1	1
B30:3	0	0	0	0	0	0	0	0	0	0	0	0	0	0	0	0
B30:4	0	0	0	0	0	0	0	0	0	0	0	0	0	0	0	0
B30:5	0	0	0	0	0	0	0	0	0	0	0	0	0	0	0	0
B30:6	0	0	0	0	0	0	0	0	0	0	0	0	0	0	0	0
B30:7	0	0	0	0	0	0	0	0	0	0	0	0	0	0	0	0
B30:8	0	0	0	0	0	0	0	0	0	0	0	0	0	0	0	0
B30:9	0	0	0	0	0	0	0	0	0	0	0	0	0	0	0	0

Symbol: B30:2/0 Radix: Binary Columns: 16

Offset	15	14	13	12	11	10	9	8	7	6	5	4	3	2	1	0
B10:0	0	0	0	0	0	0	0	0	0	0	0	0	0	0	0	0
B10:1	0	0	0	0	0	0	0	0	0	0	0	0	0	0	0	0
B10:2	0	0	0	0	0	0	0	0	0	0	0	0	0	0	0	0
B10:3	0	0	0	0	0	0	0	0	0	0	0	0	0	0	0	0
B10:4	0	0	0	0	0	0	0	0	0	0	0	0	0	0	0	0
B10:5	0	0	0	0	0	0	0	0	0	0	0	0	0	0	0	0
B10:6	0	0	0	0	0	0	0	0	0	0	0	0	0	0	0	0
B10:7	0	0	0	0	0	0	0	0	0	0	0	0	0	0	0	0
B10:8	0	0	0	0	0	0	0	0	0	0	0	0	0	0	0	0
B10:9	0	0	0	0	0	0	0	0	0	0	0	0	0	0	0	0

Symbol: B10:0/0 Radix: Binary Columns: 16

In the same manner, this 16-bit Analog Input Object File has bit 1/bit 0 of B36:0, B36:1 and B36:2 configured to 0/1, 1/0 and 1/1 respectively. The event for the index 0 of 16-bit Analog Input Object will be generated as a Class 1 event, the event for the index 1 as a Class 2 event, and the event for the index 2 as a Class 3

event, if there are any changes for the points(N14:0, N14:1 or N14:2). For any other 16-bit Analog Input points, the events will not be generated.

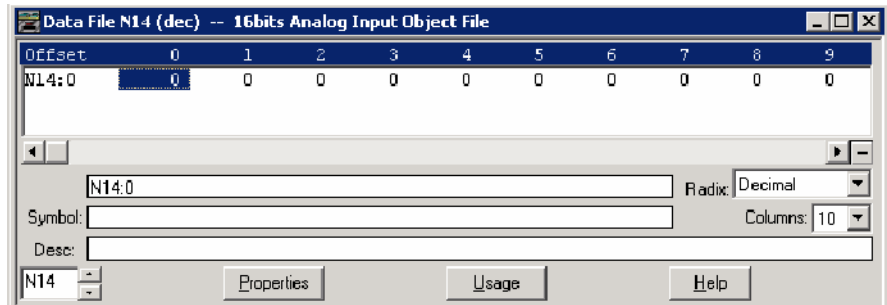
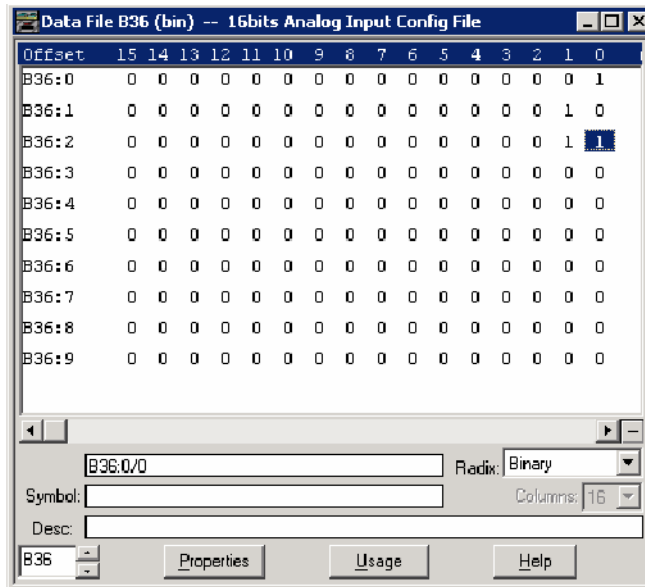

DNP3 10K Event Logging

The number of events logged can be increased from 6013 to 10000 by utilizing the memory space of Recipe and Data log. A status bit S:36/11 is used to differentiate between the two DNP3 configurations on controller power up. When the downloaded user program has S:36/11 bit set, on the next power cycle, the 10000 event configuration is loaded. Similarly, if the downloaded user

program has S:36/11 bit reset to zero, on the next power cycle, the 6013 event logging configuration is loaded.

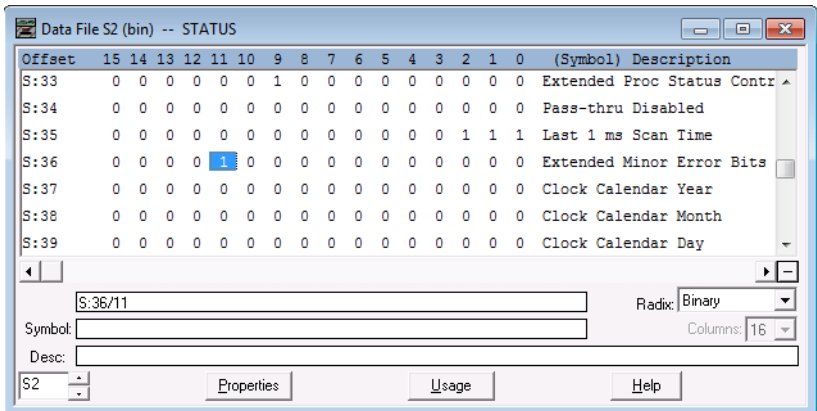

When the controller is configured for 10000 events logging, Recipe and/or Data Logging operations are not allowed. If the user program has either of the two configurations (DLG and/or RCP) when 10000 DNP3 event logging is enabled, the controller enters a fault state (0x2A) when switching from Program to Run mode.

When there is a change in configuration either from 6013 to 10000 event logs or from 10000 to 6013 event logs in the last downloaded user program, a power cycle is needed to apply the configuration, without which the controller enters a fault state (0x2B) when switched to Run mode.

S:36/11 bit has to be set to one or zero in the user program prior to downloading. This bit is read-only when the controller is in Program or Run mode.

Control Generating Event

The MicroLogix 1400 checks all elements in the Object Data file for changes at the end of a scan and generates events where needed.

The key method to turn on and off event generating by ladder logic is to assign or un-assign the Class information bits in the Object Config Files.

The example below shows how to control the event generation condition by ladder logic and implements Deadband for Analog Input Objects (which is only necessary for Series A MicroLogix 1400)

In this example, for 16-bit Analog Input point 0(N11:0), if the absolute value of the difference between the present value of N11:0 and the value that was most recently queued as an event for that point exceeds the deadband value, then an event is generated for that point.

Data File List

Name	Number	Type	Scope	Debug	Words	Elements	Last
Output	0	O	Global	No	18	6	O:5
Input	1	I	Global	No	24	8	I:7
Status	2	S	Global	No	0	66	S:65
Binary	3	B	Global	No	1	1	B3:0
Timer	4	T	Global	No	3	1	T4:0
Counter	5	C	Global	No	3	1	C5:0
Control	6	R	Global	No	3	1	R6:0
Integer	7	N	Global	No	1	1	N7:0
Float	8	F	Global	No	2	1	F8:0
16-bit Analog Input Object File	11	N	Global	No	10	10	N11:9
Binary Output Object File	12	B	Global	No	10	10	B12:0
16-bit32-bit Analog Input Config File	21	B	Global	No	10	10	B21:9
A16I OLD	30	N	Global	No	10	10	N30:9
A16I DEADB	31	N	Global	No	10	10	N31:9
A16I Temp	32	N	Global	No	10	10	N32:9

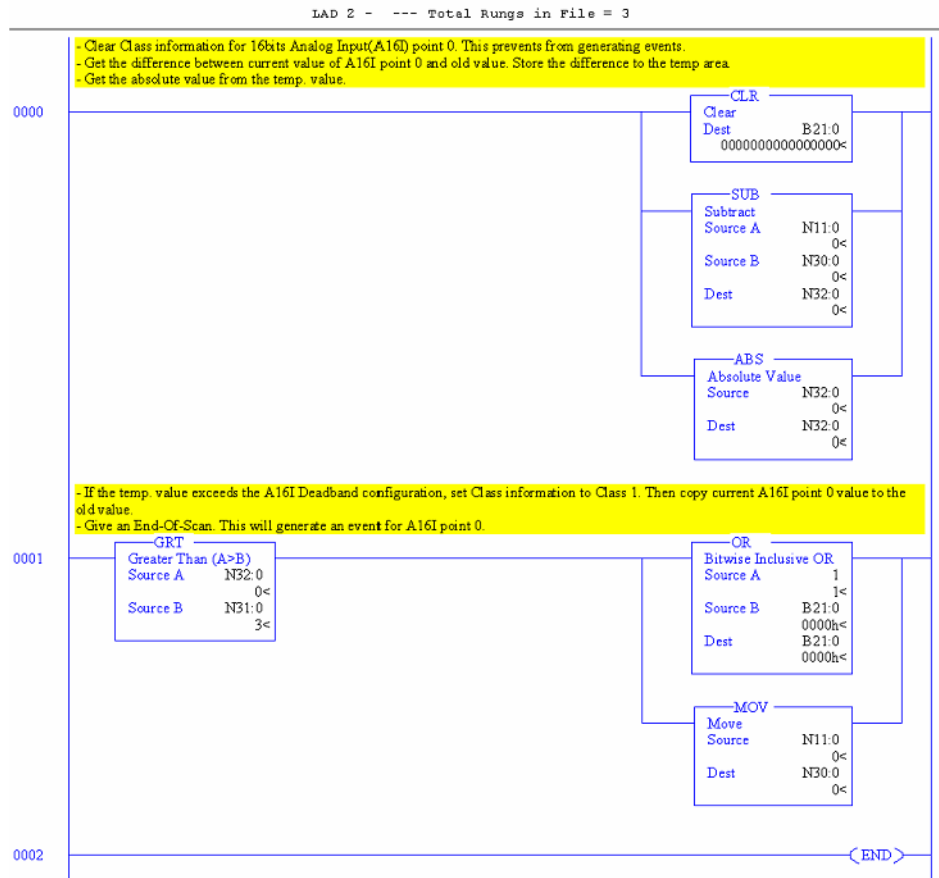

In the MicroLogix 1400 Series B and Series C controllers, new configuration files are defined for the Deadband for Analog Input Objects and the Threshold for Counter Objects. The feature of the configuration files replaces the ladder program in this section.

Reporting Event By Polled Response

When a DNP3 Master sends a poll to read Class events, any events logged to the event buffer will be reported in the polled response.

When using both Channel 0 and Channel 2 Serial ports for DNP3 communication, event polling requests should be sent to one Channel at a time. This avoids mis-reporting of events to different DNP3 Masters on different Channels. For example, Master A and Master B are connected to Channel 0 and Channel 2 respectively, and 5000 events are logged in the event buffer. Master A sends an event polling request, and only 50 events can be fit in an application layer fragment. The first 50 events are sent to Master A and the next 50 events may be sent to Master B instead.

Reporting Event By Unsolicited Response

To initiate and send Unsolicited Responses to a DNP3 Master, the parameters below should be configured correctly. For more details, see [DNP3 Slave Application Layer Configuration Parameters on page 269](#).

- Master Node0
- Channel for Unsolicited Response
- Enable Unsolicited On Start Up
- Enable Unsolicited For Class1
- Enable Unsolicited For Class2
- Enable Unsolicited For Class3
- Send Initial Unsolicited On Start Up
- Number of Class1 Events
- Hold Time after Class1 Events (x1s)
- Number of Class2 Events
- Hold Time after Class2 Events (x1s)
- Number of Class3 Events
- Hold Time after Class3 Events (x1s)
- DNP3 Object Data File Number
- DNP3 Object Config File Number
- content of the Config File

In some cases, MicroLogix 1400 may not send an Unsolicited Response even though the parameters are configured properly.

- Normally, when the parameter Enable Unsolicited On Start Up is checked, the MicroLogix 1400 initiates an Unsolicited Response with the function code ENABLE_UN SOLICITED(20), if there are any events logged into the event buffer. However, when a request with the function code DISABLE_UN SOLICITED(21) is received, an Unsolicited Response will not be sent.
- When the parameter Enable Unsolicited On Start Up is unchecked, the MicroLogix 1400 does not trigger the Unsolicited Response until a request with the function code ENABLE_UN SOLICITED(20) from the DNP3 Master is received.

The example below shows how to initiate and send the Unsolicited Response. Master Node0 in Channel 0 Configuration tab indicates that the Unsolicited Response is reported to the Master with the node address 3.

The screenshot shows the 'Channel Configuration' dialog box with the following settings:

- General:** Driver: DNP3 Slave, Node Address: 1, Baud: 19200, Parity: NONE, Stop Bits: 1.
- DNP3 Master Node Address:** Master Node0: 3, Master Node1: 0, Master Node2: 0, Master Node3: 0, Master Node4: 0.
- Protocol Control:** Control Line: No Handshaking, Confirmation Timeout (x20 ms): 1, Request LL Confirmation: , Send LL Confirmation: , Message Retries: 0, Max Random Delay (x1 ms): 0, Pre Transmit Delay (x1 ms): 0.

The parameter Channel for Unsolicited Response in the DNP3 Slave Configuration tab indicates that the Unsolicited Response is reported via Channel 0 only. In this example, Initial Unsolicited Response is sent on startup

and all events of class 1, 2 and 3 are reported. Since Hold Times are configured to 5 seconds, generated events will be reported after 5 seconds.

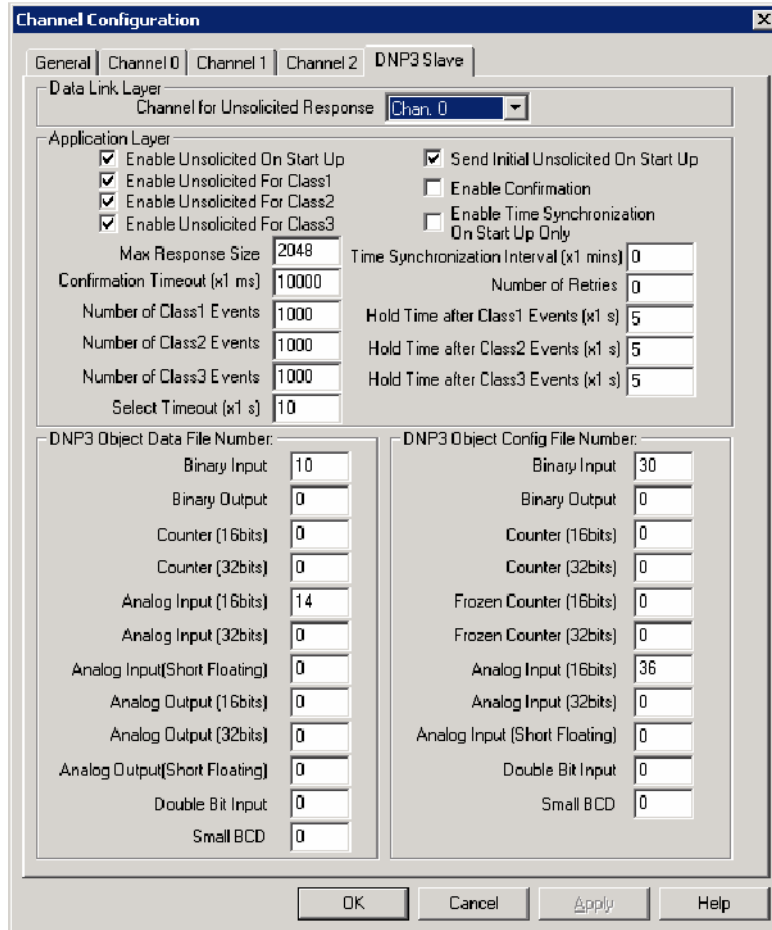

Collision Avoidance

The MicroLogix 1400 controller currently supports the first of the two methods listed below for collision avoidance.

- Detecting transmitted data (TX/RX line on RS485 communication).
- Detecting out-of-band carrier (DCD on RS232C communication).

When the MicroLogix 1400 is connected to RS485 network, it monitors all data on the link. If the MicroLogix 1400 is preparing to transmit a packet and finds the link busy, it waits for an interval defined by the Backoff_Time until it is no longer busy.

$$\text{Backoff_Time} = \text{Pre Transmit Delay (x1 ms)} + \text{Max Random Delay (x1 ms)}$$

The Pre Transmit Delay (x1 ms) in the Link Layer Channel Configuration file is a fixed delay and the Max Random Delay (x1 ms) in the Channel Configuration file is a maximum random delay for Channel 0 and Channel 2. You must specify those parameters to get the collision avoidance mechanism.

After the Backoff_Time, the MicroLogix 1400 tries again, either indefinitely, or up to a configurable maximum number of retries. If a maximum is used, the protocol considers this as a link failure.

Time Synchronization

The time value in the embedded RTC module of the MicroLogix 1400 controller is updated by an RTC Function file every 2 seconds. This resolution is insufficient to log DNP3 events in a DNP3 subsystem. Another timer, incremented by 1 millisecond in the DNP3 Slave subsystem, serves to provide appropriate resolution.

These two timers are synchronized by the following conditions:

- power up
- a request for time synchronization from DNP3 Master.

At power up, the DNP3 subsystem gets the time from an RTC function file in the MicroLogix 1400. For the RTC function file to acquire the correct time, the RTC module should be enabled before a power cycle to acquire the correct time from the RTC function file.

In this example RTC function file, the RTC module is disabled. To enable it, click "Set Date & Time" while it is online.

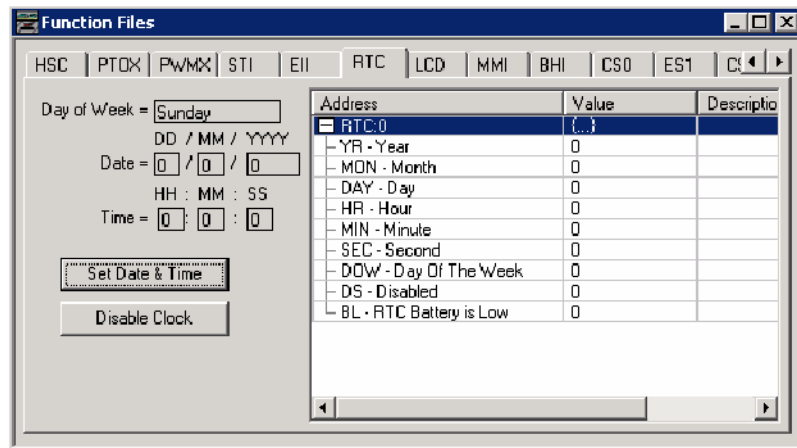

When there is a write request for time synchronization from a DNP3 Master, DNP3 subsystem synchronizes its timer with the time from DNP3 Master and the time in RTC module is synchronized with the time from DNP3 Master.

This table shows RTC Accuracy. Configure the NEED_TIME IIN bit according to this table, so that a DNP3 Master can send the time synchronization request for more accurate times in the controller.

RTC Accuracy

Ambient Temperature	RTC Accuracy ⁽¹⁾
0 °C (32 °F)	-13...-121 seconds/month
25 °C (77 °F)	54...-5 seconds/month
40 °C (104 °F)	29...-78 seconds/month
55 °C (131 °F)	-43...-150 seconds/month

⁽¹⁾ These numbers are maximum worst case values over a 31-day month.

Download a User Program via DNP3 Network

Using File-Control/Status of Requested Operation objects, a user program can be downloaded/uploaded/initialized via DNP3 communication. Also, Serial Channel 0 Status File, Ethernet Channel 1 Status File, and Serial Channel 2 Status File can be uploaded from the MicroLogix 1400.

All File-Control/Status of Requested Operation objects and supported File-Control/Status of Requested Operation objects are listed in this section. Unsolicited Response for File-Control/Status of Requested Operation objects is not supported. All the responses are sent to DNP3 Master with Function Code 129(81h).

- g70v1 File-Control - File identifier : superseded, not supported
- g70v2 File-Control - Authentication : supported
- g70v3 File-Control - File command : supported
- g70v4 File-Control - File command status : supported
- g70v5 File-Control - File transport : supported
- g70v6 File-Control - File transport status : supported
- g70v7 File-Control - File descriptor : supported
- g70v8 File-Control - File specification string : not supported by Series A controllers, supported by Series B and Series C controllers
- g91v1 Status of Requested Operation - Activate configuration : not supported by Series A controllers, supported by Series B and Series C controllers

Default Directories and Files

The MicroLogix 1400 has default directories and files for file handling in a DNP3 subsystem.

The default directories and files can be read from the controller using the function code OPEN_FILE(25), Read(1), and CLOSE_FILE(26).

Currently supported directories are "/EXE" and "/DIAG". Supported files are listed in this section. These directories/files cannot be removed and cannot be created using DNP3 requests.

Supported Files and Directories

Root Level	Directory Level	File Level	Full name string to access
"/			"/
	"EXE"		"/EXE"
		"[processorName].IMG"	"/EXE/[processorName].IMG"
	"DIAG"		"/DIAG"
		"CH0.CSF"	"/DIAG/CH0.CSF"
		"CH1.ESF"	"/DIAG/CH1.ESF"
		"CH2.CSF"	"/DIAG/CH2.CSF"

- The directory/file names must all be in capital letters.
- Root level can only be a directory marker. The directory marker is "/" for Series A, or "\" for Series B and Series C.
- Directory level can only contain directories.
- File level can only contain files.

Note that the directory marker is different in the MicroLogix 1400 Series A and Series B and Series C controllers. The directory marker is "/" for Series A and "\" for Series B and Series C controllers. In this document, "/" is used to explain File Object feature.

Generating *.IMG files using RSLogix 500/RSLogix Micro

Typically, RSLogix 500/RSLogix Micro stores the ladder program as "RSLogix Files (*.RSS)". However, to download a ladder program using a File Object via DNP3 network, you must save your ladder program in the "RSLogix IMG Files (*.IMG)" format.

After you write your ladder program, select "Save As ..." from the File menu of RSLogix 500/RSLogix Micro. Select the save type as "RSLogix IMG Files (*.IMG)"

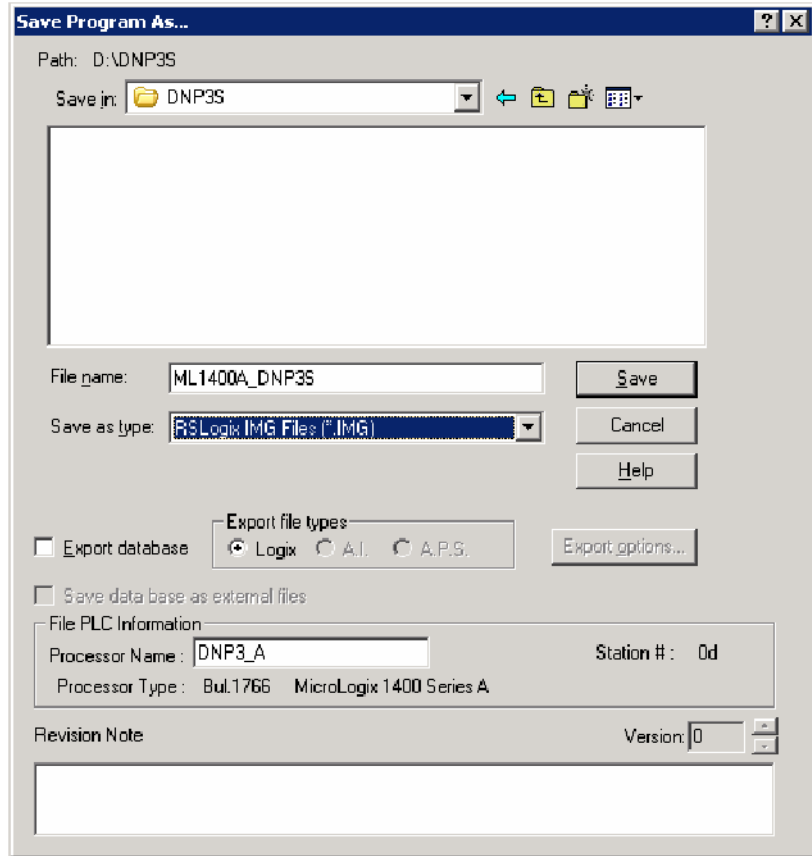

After saving the file, you can see the file "ML1400A_DNP3S.IMG". This is the file to be used for download.

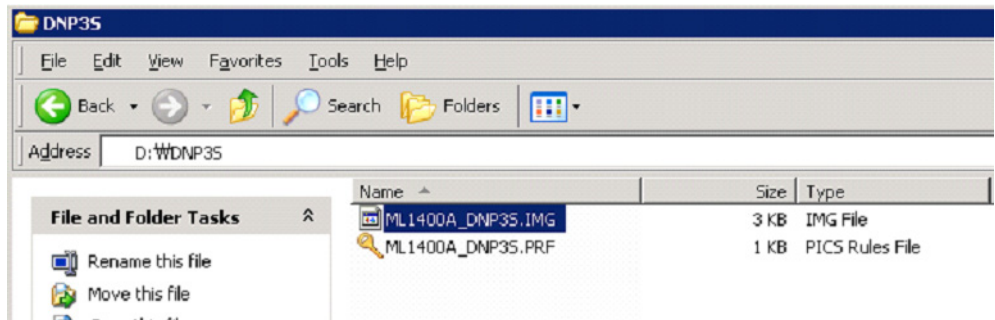

IMPORTANT RSLogix 500/RSLogix Micro v8.10.00 and the MicroLogix 1400 Series A controller do not support the opening of *.IMG files. Be sure to store your ladder program in the RSLogix Files (*.RSS) format before generating RSLogix IMG Files (*.IMG). Otherwise, you may lose the latest modifications to your ladder program.

IMPORTANT RSLogix 500/RSLogix Micro v8.30.00 and the MicroLogix 1400 Series B and Series C controller support the opening of *.IMG files. However, some information is not stored into the IMG file, for example, rung comments. Be sure to store your ladder program in the RSLogix Files (*.RSS) format before generating RSLogix IMG Files (*.IMG).

Rules for File Authentication

The File Authentication process is optional, and unnecessary when the master password of the downloaded ladder program is not configured.

Note: There is no master password for ML1400 Series B (Enhanced Password Security) program, so the file authentication process does not apply for ML1400 Series B (Enhanced Password Security). If you need file security, we recommend turning on the DNP3 authentication feature.

When the password in the ladder program is configured by RSLogix 500/RSLogix Micro, the DNP3 master sends a request with the function code AUTHENTICATE_FILE (29) to authenticate permission before file operation.

The object g70v2 is used for File Authentication, with two parameters:

- Username — from the Processor Name in the Controller Properties dialog in RSLogix 500/RSLogix Micro
- Password — from the Master Password in the Controller Properties dialog in RSLogix 500/RSLogix Micro.

In the example below, Username is "DNP3_A" and Password is "12345"("*****").

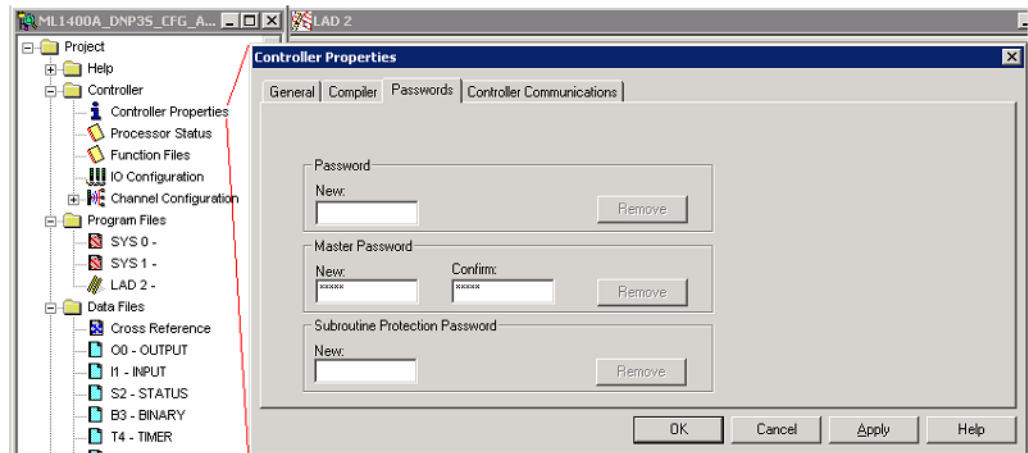
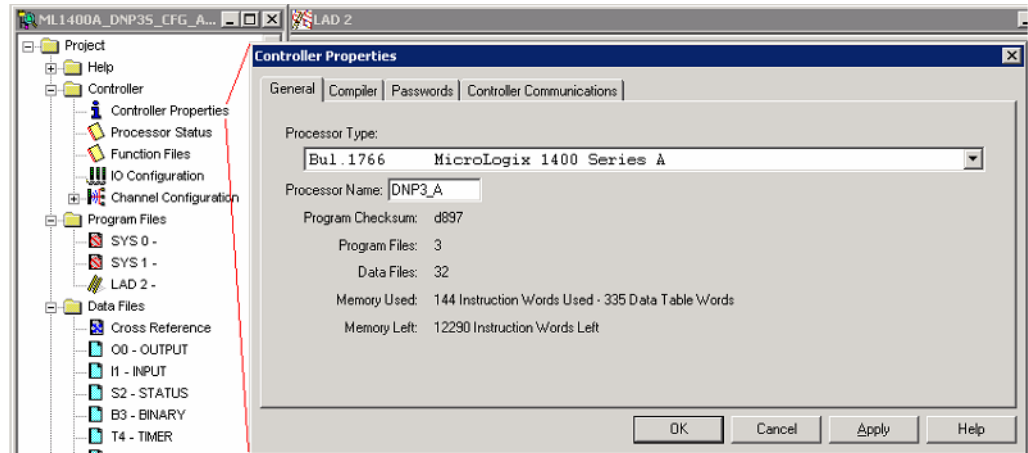

Once the DNP3 Master receives a proper Authentication Key (Non-zero value) from the MicroLogix 1400, the Authentication Key must be used for sending the request with the function code OPEN_FILE(25) or DELETE_FILE(27).

Rules for Downloading a User Program

A DNP3 master should send the function code OPEN_FILE(25), WRITE(2), and CLOSE_FILE(26) for downloading user programs.

When a master sends the function code OPEN_FILE(25) with the file command object, the file name string in File command object must be in this directory and file name format:

- /EXE/[processorName].IMG

The directory and file name extension string must all be in capital letters and the string size cannot be exceed 64 bytes. The file name [processorName] is from the Processor Name in the Controller Properties dialog in RSLogix 500/RSLogix Micro.

This ladder program [processorName].IMG is generated from RSLogix 500/RSLogix Micro. DNP3 Master should send the [processorName].IMG file without any modification.

When the MicroLogix 1400 Series A controller receives a request with the function code WRITE(2) for User Program download, the MicroLogix 1400 activates all configurations as well as channel configurations after the last application file segment is received. For the MicroLogix 1400 Series B and Series C controller, the function code Activate Configuration (0x1F) is supported.

Unlike Series A controller, the MicroLogix 1400 Series B and Series C controller does not activate all configurations as well as channel configurations after the last application file segment is received. To activate all configurations, you need to send a command with the function code, Activate Configuration (0x1F) after downloading the user program.

Maximum file size is 384 Kbytes. The MicroLogix 1400 supports downloading up to 256Kbyte size of user program when Recipe is not configured. When Recipe is configured, Maximum file size is 384 Kbytes.

The first application segment of the ladder program should be larger than or equal to the size of System Exe File structure, 64 bytes.

An application segment of the ladder program cannot be exceed 2048 bytes.

When the MicroLogix 1400 receives the first application segment, it acquires Edit Resource from the system. If the last application segment is received properly, the MicroLogix 1400 returns Edit Resource to the system. After acquiring Edit Resource, each of the application segments should be received within the Edit Resource/Owner Timeout.

The MicroLogix 1400 controller checks the integrity of the program after receiving the last application segment. If the downloaded user program fails the integrity check, MicroLogix 1400 clears the downloaded user program and restores the default user program. In this case, the configured Channel configuration is not changed from the last valid configuration.

A user program cannot be downloaded while the controller is in Executing mode. Before downloading, send a mode change request with the function code STOP_APPL(18). See [Starting and Stopping User Programs \(Mode Change\) via DNP3 Network on page 353](#) for more details.

Executing modes include Run, Remote Run, Test Continuous Scan, and Test Single Scan modes. Any others are Non-Executing modes.

Rules for Uploading a User Program

A DNP3 master should send the function code OPEN_FILE(25), READ(1), and CLOSE_FILE(26) for uploading user programs.

When a master sends the function code OPEN_FILE(25) with the file command object, the file name string in File command object must be in this directory and file name format:

- /EXE/[processorName].IMG

The directory and file name extension string must all be in capital letters and the string size cannot be exceed 64 bytes. The file name [processorName] is from the Processor Name in the Controller Properties dialog in RSLogix 500/RSLogix Micro.

The maximum file size is 384 Kbytes. The MicroLogix 1400 supports uploading of user programs up to 256Kbyte in size when Recipe is not configured. When Recipe is configured, Maximum file size is 384 Kbytes.

The first application segment of the ladder program should be larger than or equal to the size of System Exe File structure, 64 bytes.

An application segment of the ladder program cannot be exceed 2048 bytes.

Rules for Initializing a User Program

A DNP3 master should send the function code DELETE_FILE(27) for initializing user programs.

When MicroLogix 1400 receives a request with the function code DELETE_FILE(27), it clears the current user program which was downloaded into the controller, and restores the default user program.

User programs cannot be initialized while the controller is in Executing mode. Before initializing programs, a mode change request should be sent with the function code STOP_APPL(18).

Rules for uploading Communication Status Files

A DNP3 master should send the function code OPEN_FILE(25), READ(1), and CLOSE_FILE(26) for uploading Communication Status Files.

The function code WRITE(2) for downloading Communication Status Files is not supported.

The file name should be "/DIAG/CH0.CSF", "/DIAG/CH1.ESF", and "/DIAG/CH2.CSF" for Channel 0, Channel 1, and Channel 2 respectively.

Starting and Stopping User Programs (Mode Change) via DNP3 Network

This section covers how to change the controller mode via DNP3 network.

To change the controller mode, use the function codes FC_INITIALIZE_APPL (16), FC_START_APPL (17) and FC_STOP_APPL (18).

If the qualifier code is 5Bh, the Application Identifier Object should be used. The Application Identifier is a string which cannot exceed 10 bytes. The string of Application Identifier is taken from the name in the Properties of the ladder file #2 in RSLogix 500/RSLogix Micro. In this example, the Application Identifier is "DNP3_TASK".

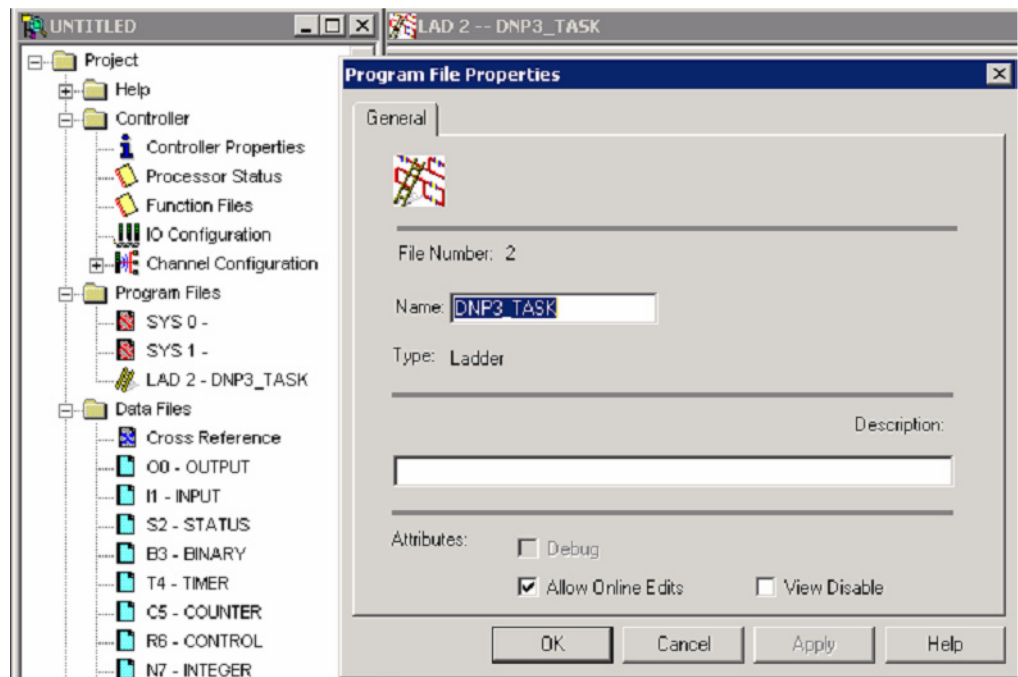

If the qualifier code is 06h, the MicroLogix 1400 controller does not check the string of the Application Identifier.

Initialize User Program

If MicroLogix 1400 receives the function code FC_INITIALIZE_APPL (16) with the object Application Identifier (g90v1), it changes mode to Remote Program. If the controller is in a fault mode, the MicroLogix 1400 clears the fault before changing the mode to Remote Program.

Start User Program

If MicroLogix 1400 receives the function code FC_START_APPL (17) with the object Application Identifier (g90v1), it changes its mode to Remote Run. If the controller is in a fault mode, it sends the command with the function code FC_INITIALIZE_APPL (16) before the command with the function code FC_START_APPL (17).

Stop User Program

If MicroLogix 1400 receives the function code FC_STOP_APPL (18) with the object Application Identifier (g90v1), it changes its mode to Remote Program. If the controller is in a fault mode, it sends the command with the function code FC_INITIALIZE_APPL (16) before sending the command with the function code FC_STOP_APPL (18).

Diagnostics

Errors in a DNP3 Slave subsystem are logged in the Communication Status File. There are 71 words for the troubleshooting.

This section shows the 71 words of the communication status file for each Channel 0 or Channel 2 port.

Communication Status File Words

Words Offset	File/Element Description for Channel 0	File/Element Description for Channel 2	Description
0	CS0:0	CS2:0	General Status Category Block ID
1	CS0:1	CS2:1	Length - 8 bytes (4 words including format code)
2	CS0:2	CS2:2	Format Code - Always 0
3	CS0:3	CS2:3	Communications Configuration Error Code
4	CS0:4	CS2:4	bit 15: Reserved - Always 0 bit 14: Modem Lost Bit bits 5...13: Reserved - Always 0 bit 4: Communications Active Bit bit 3: Selection Status Bit bit 2: Outgoing Message Command Pending bit 1: Incoming Message Reply Pending bit 0: Incoming Command Pending
5	CS0:5	CS2:5	bits 8...15: Baud Rate that the selected link layer driver is operating at out communication channel. bits 0...7: Node Address
6	CS0:6	CS2:6	Diagnostic Counters Category Identifier
7	CS0:7	CS2:7	Length
8	CS0:8	CS2:8	Format Code

Communication Status File Words

Words Offset	File/Element Description for Channel 0	File/Element Description for Channel 2	Description
9	CS0:9	CS2:9	bits 4..15: Reserved modem control line states - Always 0 bit 3: Data Carrier Detect bit 2: Reserved modem control line state - Always 0 bit 1: Request To Send bit 0: Clear To Send
10	CS0:10	CS2:10	Total Packets Sent
11	CS0:11	CS2:11	Total Packets Received for this node
12	CS0:12	CS2:12	Total Packets Observed
13	CS0:13	CS2:13	Undelivered Message Packets
14	CS0:14	CS2:14	Message Packets Retried
15	CS0:15	CS2:15	NAK Packets Received
16	CS0:16	CS2:16	Link Layer Error Count
17	CS0:17	CS2:17	Link Layer Error Codes 0: ERR_NO_ERROR 1: ERR_NO_RX_BUFFER 2: ERR_TOO_SHORT 3: ERR_TOO_LONG 4: ERR_UART_ERROR 5: ERR_BAD_CRC 6: ERR_CTS_TIMEOUT 7: ERR_CTS_DROP_MID_PKT 8: ERR_UNKNOWN_CHAR
18	CS0:18	CS2:18	Reserved - Always 0
19	CS0:19	CS2:19	Reserved - Always 0
20	CS0:20	CS2:20	Reserved - Always 0
21	CS0:21	CS2:21	Reserved - Always 0
22	CS0:22	CS2:22	Reserved - Always 0
23	CS0:23	CS2:23	Data Link Layer Active Node Table
24	CS0:24	CS2:24	Length
25	CS0:25	CS2:25	Format Code
26	CS0:26	CS2:26	Number of Nodes
27	CS0:27	CS2:27	Reserved - Always 0
28	CS0:28	CS2:28	Reserved - Always 0
29	CS0:29	CS2:29	Reserved - Always 0
30	CS0:30	CS2:30	Reserved - Always 0
31	CS0:31	CS2:31	Reserved - Always 0
32	CS0:32	CS2:32	Reserved - Always 0
33	CS0:33	CS2:33	Reserved - Always 0
34	CS0:34	CS2:34	Reserved - Always 0
35	CS0:35	CS2:35	Reserved - Always 0
36	CS0:36	CS2:36	Reserved - Always 0
37	CS0:37	CS2:37	Reserved - Always 0
38	CS0:38	CS2:38	Reserved - Always 0

Communication Status File Words

Words Offset	File/Element Description for Channel 0	File/Element Description for Channel 2	Description
39	CS0:39	CS2:39	Reserved - Always 0
40	CS0:40	CS2:40	Reserved - Always 0
41	CS0:41	CS2:41	Reserved - Always 0
42	CS0:42	CS2:42	Reserved - Always 0
43	CS0:43	CS2:43	List Category ID (10)
44	CS0:44	CS2:44	Length (14)
45	CS0:45	CS2:45	Format Code (2)
46	CS0:46	CS2:46	Pre-Send Time Delay
47	CS0:47	CS2:47	Node Address for this Slave
48	CS0:48	CS2:48	Reserved - always 0
49	CS0:49	CS2:49	RTS Send Delay
50	CS0:50	CS2:50	RTS Off Delay
51	CS0:51	CS2:51	bits 0-7: Baud Rate bits 8-9: Parity bits 10-15: Reserved - Always 0
52	CS0:52	CS2:52	List Category ID (6)
53	CS0:53	CS2:53	Length (32)
54	CS0:54	CS2:54	Format Code (2)
55	CS0:55	CS2:55	Application Layer Error Codes 0: NO_ERROR - No error found in the Application Layer. 1: FC_CANNOT_BROADCAST - Reserved 2: FC_NOT_SUPPORTED - The received packet has unsupported Function Code. 3: OBJ_NOT_SUPPORTED - The received packet has unsupported object(s). 4: BAD_REQUEST_LENGTH - Reserved 5: CONFIGURATION_ERROR - The error was caused by the invalid configuration during packet generating. E.g. invalid Data Set Configuration. 6: BAD_PARAMETER - The received packet has invalid parameters except Function Code and Object Codes. E.g. invalid Qualifier codes. 7: BAD_FILE_TYPE - The error was caused by invalid configuration in DNP3 Slave Application Layer. Invalid File Type specified. 8: BAD_FILE_NUMBER - The error was caused by invalid configuration in DNP3 Slave Application Layer. Invalid File Number specified. 9: BAD_DNP3_ADDRESS - The error was caused by invalid configuration in DNP3 Slave Application Layer. Invalid File Number specified. 10: TABLE_WRITE_PROTECTED - The specified DNP3 object data file has been locked to be written. 11: TABLE_ACCESS_DENIED - The specified DNP3 object data file has been locked to be read or written. 12: TABLE_OWNERSHIP_ERROR - The specified DNP3 object data file has been locked to be read or written. If an error code is within 6 to 12, related file number and element number are shown in word 59 and 60.
56	CS0:56	CS2:56	Application Layer Error Count
57	CS0:57	CS2:57	Function Code that caused the last error
58	CS0:58	CS2:58	Last Transmitted IIN in the response
59	CS0:59	CS2:59	Data file number of last error request
60	CS0:60	CS2:60	Data element number of last error request
61	CS0:61	CS2:61	Received Confirm Function Code Counter

Communication Status File Words

Words Offset	File/Element Description for Channel 0	File/Element Description for Channel 2	Description
62	CS0:62	CS2:62	Received Read Function Code Counter
63	CS0:63	CS2:63	Received Write Function Code Counter
64	CS0:64	CS2:64	Received Etc Function Code Counter
65	CS0:65	CS2:65	Transmitted Solicited Response Function Code Counter
66	CS0:66	CS2:66	Transmitted Unsolicited Response Function Code Counter
67	CS0:67	CS2:67	Number of events to be reported
68	CS0:68	CS2:68	Transport Function Layer Error Codes 0: NO_ERROR - No error found in the Transport Layer. 1: DISCARD_NOT_FIRST_SEG - The received packet was discarded since it was not a first segment. 2: DISCARD_DUPLICATED_AND_MORE_SEG - The received packet was discarded since it had the same sequence number as previous, more segments are expected. 3: DISCARD_DUPLICATED_AND_FINAL_SEG - The received packet was discarded since it had the same sequence number as previous, final segment received. 4: DISCARD_OUT_OF_ORDER_SEG - The received packet was discarded since the sequence number was out of order.
69	CS0:69	CS2:69	Transport Layer Error Count
70	CS0:70	CS2:70	End Of List Category ID (0)

The elements can be seen in the Function Files for each Channel.

Address	Value	Description
CS0:0	0	
CS0:1	0	
CS0:2	0	
CS0:3	0	
CS0:4	0	
CS0:5	0	
CS0:6	0	
CS0:7	0	
CS0:8	0	
CS0:9	0	
CS0:10	0	
CS0:11	0	
CS0:12	0	
CS0:13	0	
CS0:14	0	
CS0:15	0	
CS0:16	0	
CS0:17	0	
CS0:18	0	
CS0:19	0	
CS0:20	0	
CS0:21	0	
CS0:22	0	
CS0:23	0	
CS0:24	0	
CS0:25	0	

Address	Value	Description
CS2:0	0	
CS2:1	0	
CS2:2	0	
CS2:3	0	
CS2:4	0	
CS2:5	0	
CS2:6	0	
CS2:7	0	
CS2:8	0	
CS2:9	0	
CS2:10	0	
CS2:11	0	
CS2:12	0	
CS2:13	0	
CS2:14	0	
CS2:15	0	
CS2:16	0	
CS2:17	0	
CS2:18	0	
CS2:19	0	
CS2:20	0	
CS2:21	0	
CS2:22	0	
CS2:23	0	
CS2:24	0	
CS2:25	0	

For the elements of the DNP3 Slave Link Layer diagnostic counter CS0:9 to CS0:17 and CS2:9 to CS2:17, the counter values are available with the structured display in RSLogix 500/RSLogix Micro as below.

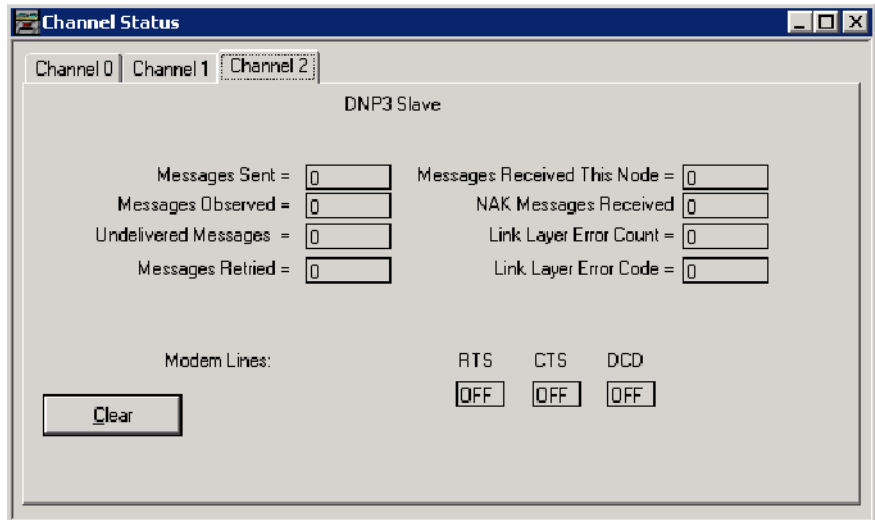
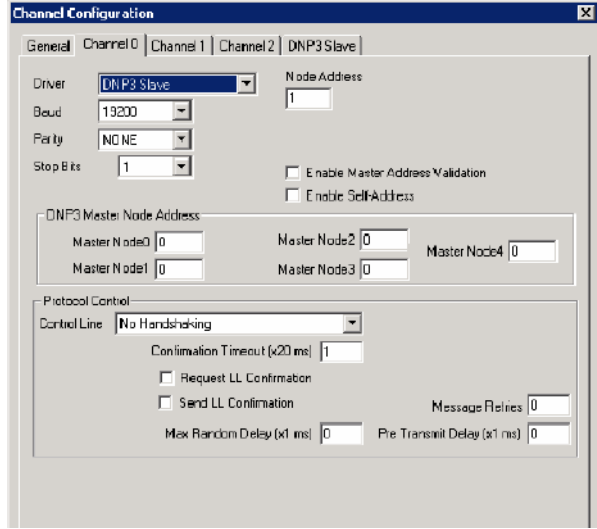

For the elements of the DNP3 Slave Application Layer diagnostic counter CS0:55 to CS0:69 and CS2:55 to CS2:69, the counter values are available with the structured display in RSLogix 500/RSLogix Micro software as below.

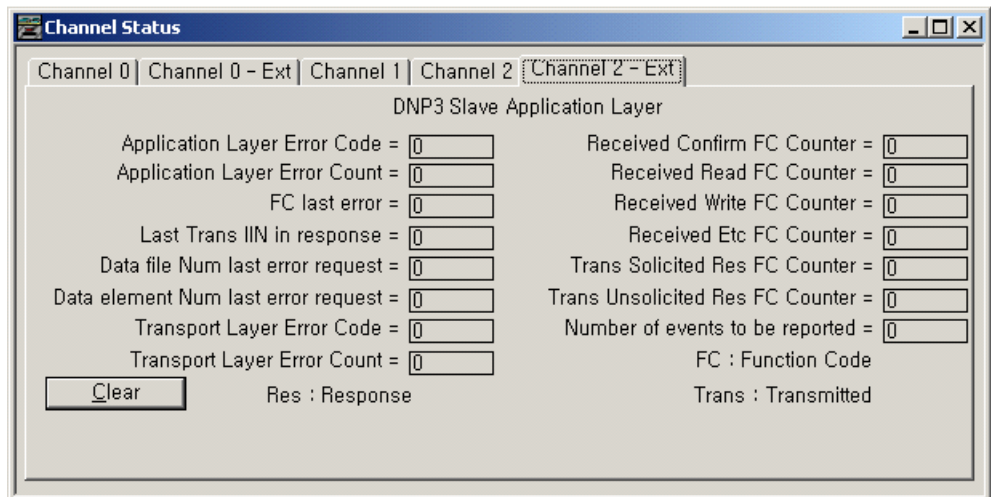
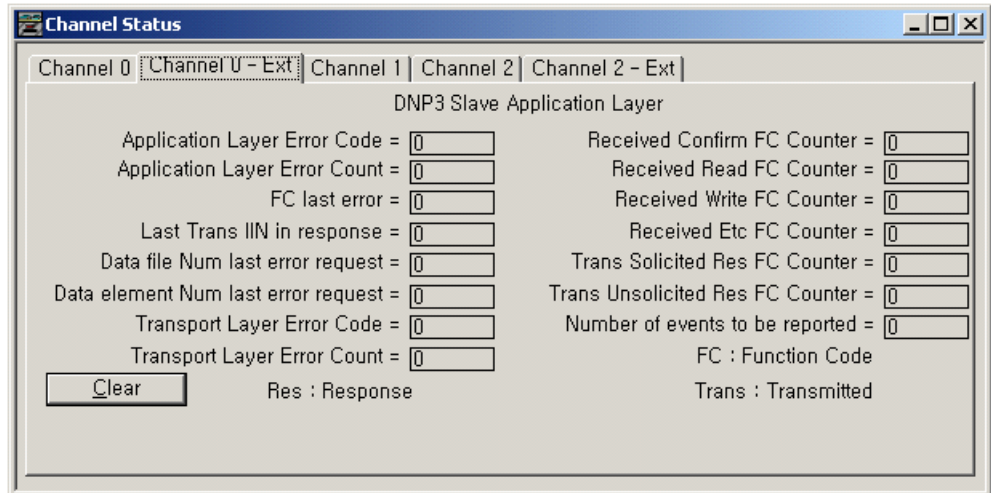

Diagnostics for Ethernet Channel (Channel 1)

This feature is supported only in MicroLogix 1400 Series B and Series C controllers.

Diagnostic Counters and Errors in DNP3 Slave subsystem for the Ethernet channel are logged in the Data File. The data file is configured in the parameter

Diagnostic File Number. This table shows the 80 words of the data file for the troubleshooting.

Data File for Troubleshooting

Word Offset	Description	Category
0	Counter for Commands Received	TCP Server - Link Layer Diagnostics for DNP3 TCP Server.
1	Counter for Commands Received with Error	
2	Counter for Replies Sent	
3	Reserved	
4	Reserved	
5	Reserved	
6	Error Count in sessions	
7	Error Code in sessions*	
8	Incoming Message Connections	
9	Maximum Connections Allowed	
10	Counter for Commands Transmitted	
11	Reserved	
12	Counter for Replies Received	
13	Reserved	
14	Reserved	
15	Reserved	
16	Reserved	
17	Reserved	
18	Reserved	
19	Reserved	

Data File for Troubleshooting

Word Offset	Description	Category
20	Counter for Commands Received	UDP Datagram - Link Layer Diagnostics for DNP3 UDP.
21	Counter for Commands Received with Error	
22	Counter for Replies Sent	
23	Reserved	
24	Reserved	
25	Reserved	
26	Error Count in sessions	
27	Error Code in sessions*	
28	Number of Sockets in use	
29	Maximum Sockets Allowed	
30	Reserved	
31	Reserved	
32	Counter for Replies Received	
33	Reserved	
34	Reserved	
35	Reserved	
36	Reserved	
37	Reserved	
38	Reserved	
39	Reserved	

Data File for Troubleshooting

Word Offset	Description	Category
40	Counter for Commands Sent	TCP Client - Link Layer Diagnostics for DNP3 TCP Client.
41	Reserved	
42	Counter for Replies Received	
43	Counter for Replies Received with Error	
44	Counter for Replies Timed Out	
45	Reserved	
46	Error Count in sessions	
47	Error Code in sessions*	
48	Outgoing Message Connections	
49	Maximum Connections Allowed	
50	Counter for Commands Received	
51	Reserved	
52	Counter for Replies Transmitted	
53	Reserved	
54	Reserved	
55	Reserved	
56	Reserved	
57	Reserved, Firmware use only	
58	Reserved, Firmware use only	
59	Reserved, Firmware use only	

Data File for Troubleshooting

Word Offset	Description	Category
60	<p>Application Layer Error Codes:</p> <p>0: NO_ERROR - No error found in the Application Layer.</p> <p>1: FC_CANNOT_BROADCAST - Reserved</p> <p>2: FC_NOT_SUPPORTED - The received packet has unsupported Function Code.</p> <p>3: OBJ_NOT_SUPPORTED - The received packet has unsupported object(s).</p> <p>4: BAD_REQUEST_LENGTH - Reserved</p> <p>5: CONFIGURATION_ERROR - The error was caused by the invalid configuration during packet generating. E.g. invalid Data Set Configuration.</p> <p>6: BAD_PARAMETER - The received packet has invalid parameters except Function Code and Object Codes. E.g. invalid Qualifier codes.</p> <p>7: BAD_FILE_TYPE - The error was caused by invalid configuration in DNP3 Slave Application Layer. Invalid File Type specified.</p> <p>8: BAD_FILE_NUMBER - The error was caused by invalid configuration in DNP3 Slave Application Layer. Invalid File Number specified.</p> <p>9: BAD_DNP3_ADDRESS - The error was caused by invalid configuration in DNP3 Slave Application Layer. Invalid File Number specified.</p> <p>10: TABLE_WRITE_PROTECTED - The specified DNP3 object data file has been locked to be written.</p> <p>11: TABLE_ACCESS_DENIED - The specified DNP3 object data file has been locked to be read or written.</p> <p>12: TABLE_OWNERSHIP_ERROR - The specified DNP3 object data file has been locked to be read or written.</p> <p>If an error code is within 6 to 12, related file number and element number are shown in word 64 and 65.</p>	DNP3 Slave - Application Layer Diagnostics for DNP3 Slave.
61	Application Layer Error Count	
62	Function Code that caused the last error	
63	Last Transmitted IIN in the response	
64	Data file number of last error request	
65	Data element number of last error request	
66	Received Confirm Function Code Counter	
67	Received Read Function Code Counter	
68	Received Write Function Code Counter	
69	Received Function Code Counter other than Confirm, Read and Write Function Codes.	
70	Transmitted Solicited Response Function Code Counter	
71	Transmitted Unsolicited Response Function Code Counter	
72	Number of events to be reported.	

Data File for Troubleshooting

Word Offset	Description	Category
73	Transport Function Layer Error Codes: 0: NO_ERROR - No error found in the Transport Layer. 1: DISCARD_NOT_FIRST_SEG - The received packet was discarded since it was not a first segment. 2: DISCARD_DUPLICATED_AND_MORE_SEG - The received packet was discarded since it had the same sequence number as previous, more segments are expected. 3: DISCARD_DUPLICATED_AND_FINAL_SEG - The received packet was discarded since it had the same sequence number as previous, final segment received. 4: DISCARD_OUT_OF_ORDER_SEG - The received packet was discarded since the sequence number was out of order.	
74	Transport Layer Error Count	
75	Reserved	
76	Reserved	
77	Reserved	
78	Reserved	
79	Reserved	
80	Reserved	

Word offset 7, 27 and 47 reflect the Error Codes that have been caused in the sessions for DNP3 TCP Server, UDP and TCP Client respectively. The following table lists the possible ranges of the Error Code. Any others are reserved.

Error Codes

Value (DEC)	Mnemonic	Description
0	NO_ERROR	No error found.
1	ERR_SOCKET_CREATE	Socket error during Create operation.
2	ERR_SOCKET_LISTEN	Socket error during Listen operation.
3	ERR_SOCKET_BIND	Socket error during Bind operation.
4	ERR_SOCKET_ACCEPT	Socket error during Accept operation.
5	ERR_SOCKET_CONNECT	Socket error during Connect operation.
6	ERR_SOCKET_SEND	Socket error during Send operation.
7	ERR_SOCKET_RECEIVE	Socket error during Receive operation.
8	ERR_SOCKET_UNLISTEN	Socket error during Unlisten operation.
9	ERR_SOCKET_UNBIND	Socket error during Unbind operation.
10	ERR_SOCKET_UNACCEPT	Socket error during Unaccept operation.
11	ERR_SOCKET_DISCONNECT	Socket error during Disconnect operation.
12	ERR_SOCKET_DELETE	Socket error during Delete operation.
13-14	Reserved	-
15	ERR_QUE_FULL	Firmware use only
16	ERR_BUFFER_ALLOC	Firmware use only
17	ERR_PACKET_ALLOC	Firmware use only

Error Codes

Value (DEC)	Mnemonic	Description
18	ERR_PACKET_RELEASE	Firmware use only
19-29	Reserved	-
30	ERR_CONN_REJECTED	Incoming Connection is rejected by the IP address validation.
31	ERR_INVALID_HEADER_CRC	Received packet header has invalid CRC.
32	ERR_INVALID_HEADER	Received packet header has invalid packet format.
33	ERR_INVALID_PACKET_CRC	Received packet has invalid CRC.
34	ERR_BAD_PACKET_RECEIVED	Received packet is unknown.
35	ERR_PACKET_REJECTED	Received packet is rejected.
36	ERR_CONNECTION_BROKEN	The connection has been broken for some reason.
37-49	Reserved	-
50	ERR_INVALID_IP_ADDRESS	Target IP Address is invalid.
51	ERR_INVALID_PORT	Target Port Number is invalid.
52-	Reserved	-

For the elements of the DNP3 Slave Application Layer diagnostic counter element offset 60 to 74, the counter values available with the structured display in RSLogix 500/RSLogix Micro software as below.

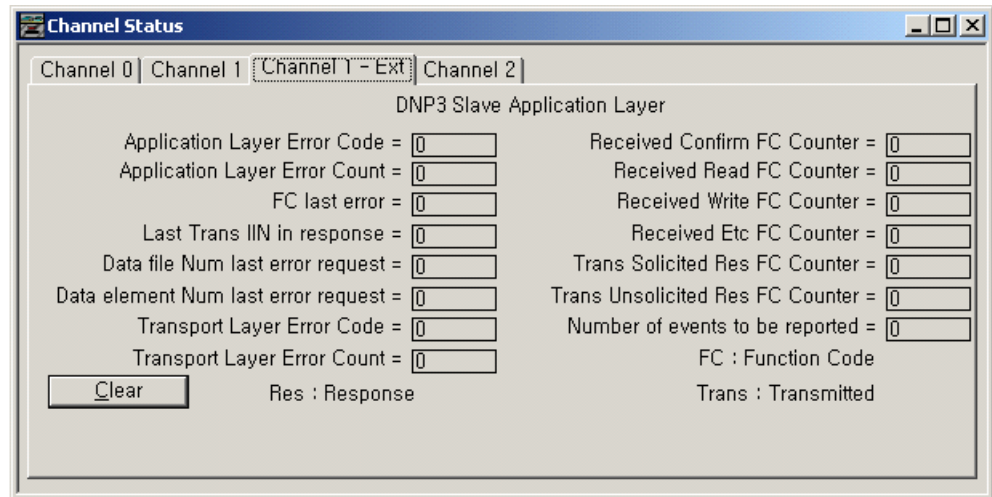

If the data file is not configured in the parameter Diagnostic File Number of the "Chan. 1 - DNP3" configuration, the "Channel 1 - Ext" dialog box will be shown as below.

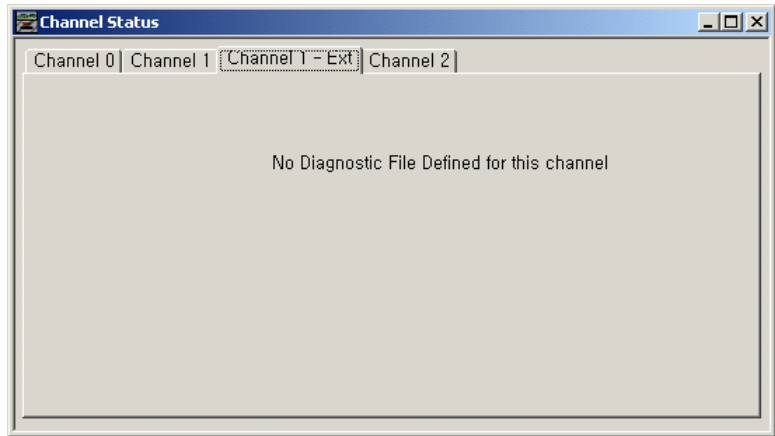

Diagnostics for Secure Authentication

This feature is supported only in MicroLogix 1400 Series B and Series C controllers.

Counters in DNP3 Slave Secure Authentication subsystem are logged in the Data File. The data file is configured in the parameter Diagnostic File Number in Secure Authentication. The following table shows the 150 words of the data file for the troubleshooting.

The 50 words are used to log the counters for each channel. Word offset 0 to 49 is for Channel 0, word offset 50 to 99 is for Channel 1 and word offset 100 to 149 is for Channel 2.

Words 6 to 49, 56 to 99, and 106 to 149 are the event counter for Challenger State Machine which is stated in the DNP3 Specification, Supplement to Volume 2, Secure Authentication, Version 2.00.

Word Offset			Current State	Description
CH0	CH1	CH2		
0	50	100	Security Idle/Wait for Reply	Authentication Error Counter
1	51	101	Security Idle/Wait for Reply	Reserved
2	52	102	Security Idle/Wait for Reply	Reserved
3	53	103	Security Idle/Wait for Reply	Reserved
4	54	104	Security Idle/Wait for Reply	Reserved
5	55	105	Security Idle/Wait for Reply	Reserved
6	56	106	Security Idle	Event Counter for Rx Unsolicited Non-Critical ASDU
7	57	107	Security Idle	Event Counter for Rx Non-Critical ASDU

Word Offset			Current State	Description
CH0	CH1	CH2		
8	58	108	Security Idle	Event Counter for Rx Critical ASDU
9	59	109	Security Idle	Event Counter for Rx Critical ASDU
10	60	110	Security Idle	Event Counter for Rx Valid Reply
11	61	111	Security Idle	Event Counter for Rx Invalid Reply
12	62	112	Security Idle	Event Counter for Reply Timeout
13	63	113	Security Idle	Event Counter for Max Invalid Replies Or Comm Failure Detected
14	64	114	Security Idle	Event Counter for Max Invalid Replies Or Comm Failure Detected
15	65	115	Security Idle	Event Counter for Rx Error Message
16	66	116	Security Idle	Event Counter for Key Change Timeout
17	67	117	Security Idle	Event Counter for Expected Key Change Timeout
18	68	118	Security Idle	Event Counter for Expected Key Change Timeout
19	69	119	Security Idle	Event Counter for Rx Key Status Request
20	70	120	Security Idle	Event Counter for Rx Valid Aggressive Mode Request
21	71	121	Security Idle	Event Counter for Rx Valid Aggressive Mode Request
22	72	122	Security Idle	Event Counter for Rx Invalid Aggressive Mode Request
23	73	123	Security Idle	Event Counter for Rx Valid Key Change
24	74	124	Security Idle	Event Counter for Rx Invalid Key Change
25	75	125	Security Idle	Event Counter for Rx Challenge
26	76	126	Security Idle	Reserved
27	77	127	Security Idle	Counter for Ignored events
28	78	128	Wait for Reply	Event Counter for Rx Unsolicited Non-Critical ASDU
29	79	129	Wait for Reply	Event Counter for Rx Non-Critical ASDU
30	80	130	Wait for Reply	Event Counter for Rx Critical ASDU
31	81	131	Wait for Reply	Event Counter for Rx Critical ASDU
32	82	132	Wait for Reply	Event Counter for Rx Valid Reply
33	83	133	Wait for Reply	Event Counter for Rx Invalid Reply
34	84	134	Wait for Reply	Event Counter for Reply Timeout
35	85	135	Wait for Reply	Event Counter for Max Invalid Replies Or Comm Failure Detected
36	86	136	Wait for Reply	Event Counter for Max Invalid Replies Or Comm Failure Detected
37	87	137	Wait for Reply	Event Counter for Rx Error Message
38	88	138	Wait for Reply	Event Counter for Key Change Timeout
39	89	139	Wait for Reply	Event Counter for Expected Key Change Timeout
40	90	140	Wait for Reply	Event Counter for Expected Key Change Timeout
41	91	141	Wait for Reply	Event Counter for Rx Key Status Request
42	92	142	Wait for Reply	Event Counter for Rx Valid Aggressive Mode Request
43	93	143	Wait for Reply	Event Counter for Rx Valid Aggressive Mode Request
44	94	144	Wait for Reply	Event Counter for Rx Invalid Aggressive Mode Request
45	95	145	Wait for Reply	Event Counter for Rx Valid Key Change

Word Offset			Current State	Description
CH0	CH1	CH2		
46	96	146	Wait for Reply	Event Counter for Rx Invalid Key Change
47	97	147	Wait for Reply	Event Counter for Rx Challenge
48	98	148	Wait for Reply	Reserved
49	99	149	Wait for Reply	Counter for Ignored events

Function Codes

These tables show the Application Layer Function codes implemented in MicroLogix 1400.

Function Codes for MicroLogix 1400 Series A Controllers

Message Type	Function Code	Name	MicroLogix 1400 Support	Description
Confirmation	0 (0x00)	FC_CONFIRM	Yes	MicroLogix 1400 parses/sends
Request	1 (0x01)	FC_READ	Yes	MicroLogix 1400 parses
Request	2 (0x02)	FC_WRITE	Yes	MicroLogix 1400 parses
Request	3 (0x03)	FC_SELECT	Yes	MicroLogix 1400 parses
Request	4 (0x04)	FC_OPERATE	Yes	MicroLogix 1400 parses
Request	5 (0x05)	FC_DIRECT_OPERATE	Yes	MicroLogix 1400 parses
Request	6 (0x06)	FC_DIRECT_OPERATE_NR	Yes	MicroLogix 1400 parses
Request	7 (0x07)	FC_IMMED_FREEZE	Yes	MicroLogix 1400 parses
Request	8 (0x08)	FC_IMMED_FREEZE_NR	Yes	MicroLogix 1400 parses
Request	9 (0x09)	FC_FREEZE_CLEAR	Yes	MicroLogix 1400 parses
Request	10 (0x0A)	FC_FREEZE_CLEAR_NR	Yes	MicroLogix 1400 parses
Request	11 (0x0B)	FC_FREEZE_AT_TIME	No	
Request	12 (0x0C)	FC_FREEZE_AT_TIME_NR	No	
Request	13 (0x0D)	FC_COLD_RESTART	Yes	MicroLogix 1400 parses. MicroLogix 1400 should not be in the executing mode and any program and files should not be in open state.
Request	14 (0x0E)	FC_WARM_RESTART	No	
Request	15 (0x0F)	FC_INITIALIZE_DATA	No	Obsolete
Request	16 (0x10)	FC_INITIALIZE_APPL	Yes	MicroLogix 1400 parses. Clears fault and changes the controller mode to Remote Program. See Starting and Stopping User Programs (Mode Change) via DNP3 Network on page 353 .
Request	17 (0x11)	FC_START_APPL	Yes	MicroLogix 1400 parses. Clears fault and changes the controller mode to Remote Run. See Starting and Stopping User Programs (Mode Change) via DNP3 Network on page 353 .
Request	18 (0x12)	FC_STOP_APPL	Yes	MicroLogix 1400 parses. Changes the controller mode to Remote Program. See Starting and Stopping User Programs (Mode Change) via DNP3 Network on page 353 .
Request	19 (0x13)	FC_SAVE_CONFIG	No	Deprecated.

Function Codes for MicroLogix 1400 Series A Controllers

Message Type	Function Code	Name	MicroLogix 1400 Support	Description
Request	20 (0x14)	FC_ENABLE_UNSOLICITED	Yes	MicroLogix 1400 parses
Request	21 (0x15)	FC_DISABLE_UNSOLICITED	Yes	MicroLogix 1400 parses
Request	22 (0x16)	FC_ASSIGN_CLASS	No	
Request	23 (0x17)	FC_DELAY_MEASURE	Yes	MicroLogix 1400 parses. Used for non-LAN
Request	24 (0x18)	FC_RECORD_CURRENT_TIME	No	Used for LAN
Request	25 (0x19)	FC_OPEN_FILE	Yes	MicroLogix 1400 parses
Request	26 (0x1A)	FC_CLOSE_FILE	Yes	MicroLogix 1400 parses
Request	27 (0x1B)	FC_DELETE_FILE	Yes	MicroLogix 1400 parses
Request	28 (0x1C)	FC_GET_FILE_INFO	No	
Request	29 (0x1D)	FC_AUTHENTICATE_FILE	Yes	MicroLogix 1400 parses
Request	30 (0x1E)	FC_ABORT_FILE	No	
Request	31 (0x1F)	FC_ACTIVATE_CONFIG	No	
Request	32 (0x20)	FC_AUTHENTICATE_REQ	No	
Request	33 (0x21)	FC_AUTHENTICATE_ERR	No	
	34 (0x22) to 128 (0x80)		No	Reserved.
Response	129 (0x81)	FC_RESPONSE	Yes	MicroLogix 1400 sends
Response	130 (0x82)	FC_UNSOLICITED_RESPONSE	Yes	MicroLogix 1400 sends
Response	131 (0x83)	FC_AUTHENTICATE_RESP	No	
	132 (0x84) to 255 (0xFF)		No	Reserved.

Function Codes for MicroLogix 1400 Series B and Series C Controllers

Message Type	Function Code	Name	MicroLogix 1400 Support	Description
Confirmation	0 (0x00)	FC_CONFIRM	Yes	MicroLogix 1400 parses/sends
Request	1 (0x01)	FC_READ	Yes	MicroLogix 1400 parses
Request	2 (0x02)	FC_WRITE	Yes	MicroLogix 1400 parses
Request	3 (0x03)	FC_SELECT	Yes	MicroLogix 1400 parses
Request	4 (0x04)	FC_OPERATE	Yes	MicroLogix 1400 parses
Request	5 (0x05)	FC_DIRECT_OPERATE	Yes	MicroLogix 1400 parses
Request	6 (0x06)	FC_DIRECT_OPERATE_NR	Yes	MicroLogix 1400 parses
Request	7 (0x07)	FC_IMMED_FREEZE	Yes	MicroLogix 1400 parses
Request	8 (0x08)	FC_IMMED_FREEZE_NR	Yes	MicroLogix 1400 parses
Request	9 (0x09)	FC_FREEZE_CLEAR	Yes	MicroLogix 1400 parses
Request	10 (0x0A)	FC_FREEZE_CLEAR_NR	Yes	MicroLogix 1400 parses
Request	11 (0x0B)	FC_FREEZE_AT_TIME	No	
Request	12 (0x0C)	FC_FREEZE_AT_TIME_NR	No	

Function Codes for MicroLogix 1400 Series B and Series C Controllers

Message Type	Function Code	Name	MicroLogix 1400 Support	Description
Request	13 (0x0D)	FC_COLD_RESTART	Yes	MicroLogix 1400 parses. MicroLogix 1400 should not be in the executing mode and any program and files should not be in open state.
Request	14 (0x0E)	FC_WARM_RESTART	No	MicroLogix 1400 parses
Request	15 (0x0F)	FC_INITIALIZE_DATA	No	Obsolete
Request	16 (0x10)	FC_INITIALIZE_APPL	Yes	MicroLogix 1400 parses. Clears fault and changes the controller mode to Remote Program. See Starting and Stopping User Programs (Mode Change) via DNP3 Network on page 353 .
Request	17 (0x11)	FC_START_APPL	Yes	MicroLogix 1400 parses. Clears fault and changes the controller mode to Remote Run. See Starting and Stopping User Programs (Mode Change) via DNP3 Network on page 353 .
Request	18 (0x12)	FC_STOP_APPL	Yes	MicroLogix 1400 parses. Changes the controller mode to Remote Program. See Starting and Stopping User Programs (Mode Change) via DNP3 Network on page 353 .
Request	19 (0x13)	FC_SAVE_CONFIG	No	Deprecated.
Request	20 (0x14)	FC_ENABLE_UNSOLICITED	Yes	MicroLogix 1400 parses
Request	21 (0x15)	FC_DISABLE_UNSOLICITED	Yes	MicroLogix 1400 parses
Request	22 (0x16)	FC_ASSIGN_CLASS	No	
Request	23 (0x17)	FC_DELAY_MEASURE	Yes	MicroLogix 1400 parses. Used for non-LAN
Request	24 (0x18)	FC_RECORD_CURRENT_TIME	No	MicroLogix 1400 parses.Used for LAN
Request	25 (0x19)	FC_OPEN_FILE	Yes	MicroLogix 1400 parses
Request	26 (0x1A)	FC_CLOSE_FILE	Yes	MicroLogix 1400 parses
Request	27 (0x1B)	FC_DELETE_FILE	Yes	MicroLogix 1400 parses
Request	28 (0x1C)	FC_GET_FILE_INFO	No	MicroLogix 1400 parses
Request	29 (0x1D)	FC_AUTHENTICATE_FILE	Yes	MicroLogix 1400 parses
Request	30 (0x1E)	FC_ABORT_FILE	No	MicroLogix 1400 parses
Request	31 (0x1F)	FC_ACTIVATE_CONFIG	No	MicroLogix 1400 parses
Request	32 (0x20)	FC_AUTHENTICATE_REQ	No	MicroLogix 1400 parses
Request	33 (0x21)	FC_AUTHENTICATE_ERR	No	MicroLogix 1400 parses
	34 (0x22) to 128 (0x80)		No	Reserved.
Response	129 (0x81)	FC_RESPONSE	Yes	MicroLogix 1400 sends
Response	130 (0x82)	FC_UNSOLICITED_RESPONSE	Yes	MicroLogix 1400 sends
Response	131 (0x83)	FC_AUTHENTICATE_RESP	No	MicroLogix 1400 sends
	132 (0x84) to 255 (0xFF)		No	Reserved.

Implementation Table

MicroLogix 1400 supports DNP3 Certification Subset Level 2.

The implementation table in this section identifies which object groups and variations, function codes and qualifiers the device supports in both requests and responses. The Request and Response columns identify all requests and responses that may be sent/parsed by a DNP3 Master, or must be parsed/sent by the MicroLogix 1400.

The implementation table lists all functionality required by either DNP3 Master or MicroLogix 1400 as defined within the DNP3 IED Conformance Test Procedures. Any functionality beyond the highest subset level supported is indicated by grayed table cells.

Implementation Table for Series A controllers

DNP Object Group & Variation			Request DNP3 Master may issue MicroLogix 1400 must parse		Response DNP3 Master must parse MicroLogix 1400 may issue	
Group Num	Var Num	Description	Function Codes (dec)	Qualifier Codes (hex)	Function Codes (dec)	Qualifier Codes (hex)
0	211-239 241-243 248-250 252	Device Attribute	1 (read)	00 (start-stop)	129 (response)	00 (start-stop)
0	240 245-247	Device Attribute	1 (read)	00 (start-stop)	129 (response)	00 (start-stop)
			2 (write)	00 (start-stop)		
0	254	Device Attribute - Non-specific all attributes request	1 (read)	00, 01 (start-stop) 06 (no range, or all)		
0	255	Device Attributes - List of attribute variations	1 (read)	00, 01 (start-stop) 06 (no range, or all)	129 (response)	00 (start-stop)
1	0	Binary Input - Any Variation	1 (read)	06 (no range, or all)		
1	1	Binary Input - Packed format	1 (read)	06 (no range, or all)	129 (response)	00, 01 (start-stop)
1	2	Binary Input - With flags	1 (read)	06 (no range, or all)	129 (response)	00, 01 (start-stop)
2	0	Binary Input Event - Any Variation	1 (read)	06 (no range, or all) 07, 08 (limited qty)		
2	1	Binary Input Event - Without time	1 (read)	06 (no range, or all) 07, 08 (limited qty)	129 (response) 130 (unsol. resp)	17, 28 (index)
2	2	Binary Input Event - With absolute time	1 (read)	06 (no range, or all) 07, 08 (limited qty)	129 (response) 130 (unsol. resp)	17, 28 (index)
2	3	Binary Input Event - With relative time	1 (read)	06 (no range, or all) 07, 08 (limited qty)	129 (response) 130 (unsol. resp)	17, 28 (index)
3	0	Double-bit Binary Input - Any Variation	1 (read)	06 (no range, or all)		
3	1	Double-bit Binary Input - Packed format	1 (read)	06 (no range, or all)	129 (response)	00, 01 (start-stop)
3	2	Double-bit Binary Input - With flags	1 (read)	06 (no range, or all)	129 (response)	00, 01 (start-stop)
4	0	Double-bit Binary Input Event - Any Variation	1 (read)	06 (no range, or all) 07, 08 (limited qty)		

Implementation Table for Series A controllers

DNP Object Group & Variation			Request DNP3 Master may issue MicroLogix 1400 must parse		Response DNP3 Master must parse MicroLogix 1400 may issue	
Group Num	Var Num	Description	Function Codes (dec)	Qualifier Codes (hex)	Function Codes (dec)	Qualifier Codes (hex)
4	1	Double-bit Binary Input Event - Without time	1 (read)	06 (no range, or all) 07, 08 (limited qty)	129 (response) 130 (unsol. resp)	17, 28 (index)
4	2	Double-bit Binary Input Event - With absolute time	1 (read)	06 (no range, or all) 07, 08 (limited qty)	129 (response) 130 (unsol. resp)	17, 28 (index)
4	3	Double-bit Binary Input Event - With relative time	1 (read)	06 (no range, or all) 07, 08 (limited qty)	129 (response) 130 (unsol. resp)	17, 28 (index)
10	0	Binary Output - Any Variation	1 (read)	06 (no range, or all)		
10	2	Binary Output - Output status with flags	1 (read)	06 (no range, or all)	129 (response)	00, 01 (start-stop)
12	1	Binary Command - Control relay output block (CROB)	3 (select) 4 (operate) 5 (direct op) 6 (dir. op, no ack)	17, 28 (index)	129 (response)	echo of request
20	0	Counter - Any Variation	1 (read) 7 (freeze) 8 (freeze noack) 9 (freeze clear) 10 (frz. cl. noack)	06 (no range, or all)		
20	1	Counter - 32-bit with flag	1 (read) 7 (freeze) 8 (freeze noack) 9 (freeze clear) 10 (frz. cl. noack)	06 (no range, or all)	129 (response)	00, 01 (start-stop)
20	2	Counter - 16-bit with flag	1 (read) 7 (freeze) 8 (freeze noack) 9 (freeze clear) 10 (frz. cl. noack)	06 (no range, or all)	129 (response)	00, 01 (start-stop)
20	5	Counter - 32-bit without flag	1 (read) 7 (freeze) 8 (freeze noack) 9 (freeze clear) 10 (frz. cl. noack)	06 (no range, or all)	129 (response)	00, 01 (start-stop)
20	6	Counter - 16-bit without flag	1 (read) 7 (freeze) 8 (freeze noack) 9 (freeze clear) 10 (frz. cl. noack)	06 (no range, or all)	129 (response)	00, 01 (start-stop)
21	0	Frozen Counter - Any Variation	1 (read)	06 (no range, or all)		
21	1	Frozen Counter - 32-bit with flag	1 (read)	06 (no range, or all)	129 (response)	00, 01 (start-stop)
21	2	Frozen Counter - 16-bit with flag	1 (read)	06 (no range, or all)	129 (response)	00, 01 (start-stop)
21	5	Frozen Counter - 32-bit with flag and time	1 (read)	06 (no range, or all)	129 (response)	00, 01 (start-stop)
21	6	Frozen Counter - 16-bit with flag and time	1 (read)	06 (no range, or all)	129 (response)	00, 01 (start-stop)

Implementation Table for Series A controllers

DNP Object Group & Variation			Request DNP3 Master may issue MicroLogix 1400 must parse		Response DNP3 Master must parse MicroLogix 1400 may issue	
Group Num	Var Num	Description	Function Codes (dec)	Qualifier Codes (hex)	Function Codes (dec)	Qualifier Codes (hex)
21	9	Frozen Counter - 32-bit without flag	1 (read)	06 (no range, or all)	129 (response)	00, 01 (start-stop)
21	10	Frozen Counter - 16-bit without flag	1 (read)	06 (no range, or all)	129 (response)	00, 01 (start-stop)
22	0	Counter Event - Any Variation	1 (read)	06 (no range, or all) 07, 08 (limited qty)		
22	1	Counter Event - 32-bit with flag	1 (read)	06 (no range, or all) 07, 08 (limited qty)	129 (response) 130 (unsol. resp)	17, 28 (index)
22	2	Counter Event - 16-bit with flag	1 (read)	06 (no range, or all) 07, 08 (limited qty)	129 (response) 130 (unsol. resp)	17, 28 (index)
23	0	Frozen Counter Event - Any Variation	1 (read)	06 (no range, or all) 07, 08 (limited qty)		
23	1	Frozen Counter Event - 32-bit with flag	1 (read)	06 (no range, or all) 07, 08 (limited qty)	129 (response) 130 (unsol. resp)	17, 28 (index)
23	2	Frozen Counter Event - 16-bit with flag	1 (read)	06 (no range, or all) 07, 08 (limited qty)	129 (response) 130 (unsol. resp)	17, 28 (index)
23	5	Frozen Counter Event - 32-bit with flag and time	1 (read)	06 (no range, or all) 07, 08 (limited qty)	129 (response) 130 (unsol. resp)	17, 28 (index)
23	6	Frozen Counter Event - 16-bit with flag and time	1 (read)	06 (no range, or all) 07, 08 (limited qty)	129 (response) 130 (unsol. resp)	17, 28 (index)
30	0	Analog Input - Any Variation	1 (read)	06 (no range, or all)		
30	1	Analog Input - 32-bit with flag	1 (read)	06 (no range, or all)	129 (response)	00, 01 (start-stop)
30	2	Analog Input - 16-bit with flag	1 (read)	06 (no range, or all)	129 (response)	00, 01 (start-stop)
30	3	Analog Input - 32-bit without flag	1 (read)	06 (no range, or all)	129 (response)	00, 01 (start-stop)
30	4	Analog Input - 16-bit without flag	1 (read)	06 (no range, or all)	129 (response)	00, 01 (start-stop)
30	5	Analog Input - Single-prec flt-pt with flag	1 (read)	06 (no range, or all)	129 (response)	00, 01 (start-stop)
32	0	Analog Input Event - Any Variation	1 (read)	06 (no range, or all) 07, 08 (limited qty)		
32	1	Analog Input Event - 32-bit without time	1 (read)	06 (no range, or all) 07, 08 (limited qty)	129 (response) 130 (unsol. resp)	17, 28 (index)
32	2	Analog Input Event - 16-bit without time	1 (read)	06 (no range, or all) 07, 08 (limited qty)	129 (response) 130 (unsol. resp)	17, 28 (index)
32	3	Analog Input Event - 32-bit with time	1 (read)	06 (no range, or all) 07, 08 (limited qty)	129 (response) 130 (unsol. resp)	17, 28 (index)
32	4	Analog Input Event - 16-bit with time	1 (read)	06 (no range, or all) 07, 08 (limited qty)	129 (response) 130 (unsol. resp)	17, 28 (index)
32	5	Analog Input Event - Single-prec flt-pt without time	1 (read)	06 (no range, or all) 07, 08 (limited qty)	129 (response) 130 (unsol. resp)	17, 28 (index)

Implementation Table for Series A controllers

DNP Object Group & Variation			Request DNP3 Master may issue MicroLogix 1400 must parse		Response DNP3 Master must parse MicroLogix 1400 may issue	
Group Num	Var Num	Description	Function Codes (dec)	Qualifier Codes (hex)	Function Codes (dec)	Qualifier Codes (hex)
32	7	Analog Input Event - Single-prec flt-pt with time	1 (read)	06 (no range, or all) 07, 08 (limited qty)	129 (response) 130 (unsol. resp)	17, 28 (index)
40	0	Analog Output Status - Any Variation	1 (read)	06 (no range, or all)		
40	1	Analog Output Status - 32-bit with flag	1 (read)	06 (no range, or all)	129 (response)	00, 01 (start-stop)
40	2	Analog Output Status - 16-bit with flag	1 (read)	06 (no range, or all)	129 (response)	00, 01 (start-stop)
40	3	Analog Output Status - Single-prec flt-pt with flag	1 (read)	06 (no range, or all)	129 (response)	00, 01 (start-stop)
41	1	Analog Output - 32-bit	3 (select) 4 (operate) 5 (direct op) 6 (dir. op, no ack)	17, 28 (index)	129 (response)	echo of request
41	2	Analog Output - 16-bit	3 (select) 4 (operate) 5 (direct op) 6 (dir. op, no ack)	17, 28 (index)	129 (response)	echo of request
41	3	Analog Output - Single-prec flt-pt	3 (select) 4 (operate) 5 (direct op) 6 (dir. op, no ack)	17, 28 (index)	129 (response)	echo of request
50	1	Time and Date - Absolute time	1 (read)	07 (limited qty = 1)	129 (response)	07 (limited qty) (qty = 1)
			2 (write)	07 (limited qty = 1)		
50	3	Time and Date - Absolute time at last recorded time				
51	1	Time and Date CTO - Absolute time, synchronized			129 (response) 130 (unsol. resp)	07 (limited qty) (qty = 1)
51	2	Time and Date CTO - Absolute time, unsynchronized			129 (response) 130 (unsol. resp)	07 (limited qty) (qty = 1)
52	1	Time Delay - Coarse			129 (response)	07 (limited qty) (qty = 1)
52	2	Time Delay - Fine			129 (response)	07 (limited qty) (qty = 1)
60	1	Class Objects - Class 0 data	1 (read)	06 (no range, or all)		
60	2	Class Objects - Class 1 data	1 (read)	06 (no range, or all) 07, 08 (limited qty)		
			20 (enbl. unsol.) 21 (dab. unsol.)	06 (no range, or all)		
60	3	Class Objects - Class 2 data	1 (read)	06 (no range, or all) 07, 08 (limited qty)		

Implementation Table for Series A controllers

DNP Object Group & Variation			Request DNP3 Master may issue MicroLogix 1400 must parse		Response DNP3 Master must parse MicroLogix 1400 may issue	
Group Num	Var Num	Description	Function Codes (dec)	Qualifier Codes (hex)	Function Codes (dec)	Qualifier Codes (hex)
60	4	Class Objects - Class 3 data	1 (read)	06 (no range, or all) 07, 08 (limited qty)		
			20 (enbl. unsol.) 21 (dab. unsol.)	06 (no range, or all)		
70	2	File-Control - authentication	29 (authenticate file)	5B (free format)	129 (response)	5B (free format)
70	3	File Control - file command	25 (open file)	5B (free format)		
70	3	File Control - file command	27 (delete file)	5B (free format)		
70	4	File Control - file command status	26 (close file)	5B (free format)	129 (response)	5B (free format)
70	5	File Control - file transport	1 (read file)	5B (free format)		
70	5	File Control - file transport	2 (write file)	5B (free format)		
70	6	File Control - file transport status			129 (response)	5B (free format)
70	7	File-Control - file descriptor			129 (response)	5B (free format)
80	1	Internal Indications - Packed format	1 (read file)	00, 01 (start-stop)	129 (response)	00, 01 (start-stop)
			2 (write file)	00 (start-stop) index=7		
90	1	Application - Identifier	16 (init. appl.) 17 (start appl.) 18 (stop appl.)	5B (free format) 06 (no range, or all)		
101	1	Binary Coded Decimal Integers - small	1 (read file)	06 (no range, or all)	129 (response)	00, 01 (start-stop)
					130 (unsol. resp)	17, 28 (index)
101	2	Binary Coded Decimal Integers - medium				
No Object (function code only)			13 (cold restart)			
No Object (function code only)			23 (delay meas.)			

Implementation Table for Series B and Series C controllers

DNP Object Group & Variation			Request DNP3 Master may issue MicroLogix 1400 must parse		Response DNP3 Master must parse MicroLogix 1400 may issue	
Group Num	Var Num	Description	Function Codes (dec)	Qualifier Codes (hex)	Function Codes (dec)	Qualifier Codes (hex)
0	211-239 241-243 248-250 252	Device Attribute	1 (read)	00, 01 (start-stop) 06 (no range, or all)	129 (response)	00 (start-stop)
0	240 245-247	Device Attribute	1 (read)	00, 01 (start-stop) 06 (no range, or all)	129 (response)	00 (start-stop)
			2 (write)	00, 01 (start-stop)		
0	254	Device Attribute - Non-specific all attributes request	1 (read)	00, 01 (start-stop) 06 (no range, or all)		
0	255	Device Attributes - List of attribute variations	1 (read)	00, 01 (start-stop) 06 (no range, or all)	129 (response)	00 (start-stop)
1	0	Binary Input - Any Variation	1 (read)	00, 01 (start-stop)		
				06 (no range, or all)		
1	1	Binary Input - Packed format	1 (read)	00, 01 (start-stop) 06 (no range, or all)	129 (response)	00, 01 (start-stop)
1	2	Binary Input - With flags	1 (read)	00, 01 (start-stop) 06 (no range, or all)	129 (response)	00, 01 (start-stop)
2	0	Binary Input Event - Any Variation	1 (read)	06 (no range, or all) 07, 08 (limited qty)		
2	1	Binary Input Event - Without time	1 (read)	06 (no range, or all) 07, 08 (limited qty)	129 (response) 130 (unsol. resp)	17, 28 (index)
2	2	Binary Input Event - With absolute time	1 (read)	06 (no range, or all) 07, 08 (limited qty)	129 (response) 130 (unsol. resp)	17, 28 (index)
2	3	Binary Input Event - With relative time	1 (read)	06 (no range, or all) 07, 08 (limited qty)	129 (response) 130 (unsol. resp)	17, 28 (index)
3	0	Double-bit Binary Input - Any Variation	1 (read)	00, 01 (start-stop) 06 (no range, or all)		
3	1	Double-bit Binary Input - Packed format	1 (read)	00, 01 (start-stop) 06 (no range, or all)	129 (response)	00, 01 (start-stop)
3	2	Double-bit Binary Input - With flags	1 (read)	00, 01 (start-stop) 06 (no range, or all)	129 (response)	00, 01 (start-stop)
4	0	Double-bit Binary Input Event - Any Variation	1 (read)	06 (no range, or all) 07, 08 (limited qty)		
4	1	Double-bit Binary Input Event - Without time	1 (read)	06 (no range, or all) 07, 08 (limited qty)	129 (response) 130 (unsol. resp)	17, 28 (index)
4	2	Double-bit Binary Input Event - With absolute time	1 (read)	06 (no range, or all) 07, 08 (limited qty)	129 (response) 130 (unsol. resp)	17, 28 (index)
4	3	Double-bit Binary Input Event - With relative time	1 (read)	06 (no range, or all) 07, 08 (limited qty)	129 (response) 130 (unsol. resp)	17, 28 (index)
10	0	Binary Output - Any Variation	1 (read)	00, 01 (start-stop)		
				06 (no range, or all)		
10	2	Binary Output - Output status with flags	1 (read)	00, 01 (start-stop) 06 (no range, or all)	129 (response)	00, 01 (start-stop)

Implementation Table for Series B and Series C controllers

DNP Object Group & Variation			Request DNP3 Master may issue MicroLogix 1400 must parse	Response DNP3 Master must parse MicroLogix 1400 may issue		
Group Num	Var Num	Description	Function Codes (dec)	Qualifier Codes (hex)	Function Codes (dec)	Qualifier Codes (hex)
12	1	Binary Command - Control relay output block (CROB)	3 (select) 4 (operate) 5 (direct op) 6 (dir. op, no ack)	17, 28 (index)	129 (response)	echo of request
20	0	Counter - Any Variation	1 (read)	00, 01 (start-stop)		
				06 (no range, or all)		
20	1	Counter - 32-bit with flag	1 (read)	00, 01 (start-stop) 06 (no range, or all)	129 (response)	00, 01 (start-stop)
20	1	Counter - 32-bit with flag	7 (freeze) 8 (freeze noack) 9 (freeze clear) 10 (frz. cl. noack)	06 (no range, or all)		
20	2	Counter - 16-bit with flag	1 (read)	00, 01 (start-stop) 06 (no range, or all)	129 (response)	00, 01 (start-stop)
20	2	Counter - 16-bit with flag	7 (freeze) 8 (freeze noack) 9 (freeze clear) 10 (frz. cl. noack)	06 (no range, or all)		
20	5	Counter - 32-bit without flag	1 (read)	00, 01 (start-stop) 06 (no range, or all)	129 (response)	00, 01 (start-stop)
20	5	Counter - 32-bit without flag	7 (freeze) 8 (freeze noack) 9 (freeze clear) 10 (frz. cl. noack)	06 (no range, or all)		
20	6	Counter - 16-bit without flag	1 (read)	00, 01 (start-stop) 06 (no range, or all)	129 (response)	00, 01 (start-stop)
20	6	Counter - 16-bit without flag	7 (freeze) 8 (freeze noack) 9 (freeze clear) 10 (frz. cl. noack)	06 (no range, or all)		
21	0	Frozen Counter - Any Variation	1 (read)	00, 01 (start-stop)		
				06 (no range, or all)		
21	1	Frozen Counter - 32-bit with flag	1 (read)	06 (no range, or all)	129 (response)	00, 01 (start-stop)
21	2	Frozen Counter - 16-bit with flag	1 (read)	00, 01 (start-stop) 06 (no range, or all)	129 (response)	00, 01 (start-stop)
21	5	Frozen Counter - 32-bit with flag and time	1 (read)	00, 01 (start-stop) 06 (no range, or all)	129 (response)	00, 01 (start-stop)
21	6	Frozen Counter - 16-bit with flag and time	1 (read)	00, 01 (start-stop) 06 (no range, or all)	129 (response)	00, 01 (start-stop)
21	9	Frozen Counter - 32-bit without flag	1 (read)	00, 01 (start-stop) 06 (no range, or all)	129 (response)	00, 01 (start-stop)
21	10	Frozen Counter - 16-bit without flag	1 (read)	00, 01 (start-stop) 06 (no range, or all)	129 (response)	00, 01 (start-stop)
22	0	Counter Event - Any Variation	1 (read)	06 (no range, or all) 07, 08 (limited qty)		
22	1	Counter Event - 32-bit with flag	1 (read)	06 (no range, or all) 07, 08 (limited qty)	129 (response) 130 (unsol. resp)	17, 28 (index)

Implementation Table for Series B and Series C controllers

DNP Object Group & Variation			Request DNP3 Master may issue MicroLogix 1400 must parse		Response DNP3 Master must parse MicroLogix 1400 may issue	
Group Num	Var Num	Description	Function Codes (dec)	Qualifier Codes (hex)	Function Codes (dec)	Qualifier Codes (hex)
22	2	Counter Event - 16-bit with flag	1 (read)	06 (no range, or all) 07, 08 (limited qty)	129 (response) 130 (unsol. resp)	17, 28 (index)
22	5	Counter Event - 32-bit with flag and time	1 (read)	06 (no range, or all) 07, 08 (limited qty)	129 (response) 130 (unsol. resp)	17, 28 (index)
22	6	Counter Event - 16-bit with flag and time	1 (read)	06 (no range, or all) 07, 08 (limited qty)	129 (response) 130 (unsol. resp)	17, 28 (index)
23	0	Frozen Counter Event - Any Variation	1 (read)	06 (no range, or all) 07, 08 (limited qty)		
23	1	Frozen Counter Event - 32-bit with flag	1 (read)	06 (no range, or all) 07, 08 (limited qty)	129 (response) 130 (unsol. resp)	17, 28 (index)
23	2	Frozen Counter Event - 16-bit with flag	1 (read)	06 (no range, or all) 07, 08 (limited qty)	129 (response) 130 (unsol. resp)	17, 28 (index)
23	5	Frozen Counter Event - 32-bit with flag and time	1 (read)	06 (no range, or all) 07, 08 (limited qty)	129 (response) 130 (unsol. resp)	17, 28 (index)
23	6	Frozen Counter Event - 16-bit with flag and time	1 (read)	06 (no range, or all) 07, 08 (limited qty)	129 (response) 130 (unsol. resp)	17, 28 (index)
30	0	Analog Input - Any Variation	1 (read)	00, 01 (start-stop) 06 (no range, or all)		
30	1	Analog Input - 32-bit with flag	1 (read)	00, 01 (start-stop) 06 (no range, or all)	129 (response)	00, 01 (start-stop)
30	2	Analog Input - 16-bit with flag	1 (read)	00, 01 (start-stop) 06 (no range, or all)	129 (response)	00, 01 (start-stop)
30	3	Analog Input - 32-bit without flag	1 (read)	00, 01 (start-stop) 06 (no range, or all)	129 (response)	00, 01 (start-stop)
30	4	Analog Input - 16-bit without flag	1 (read)	00, 01 (start-stop) 06 (no range, or all)	129 (response)	00, 01 (start-stop)
30	5	Analog Input - Single-prec flt-pt with flag	1 (read)	00, 01 (start-stop) 06 (no range, or all)	129 (response)	00, 01 (start-stop)
32	0	Analog Input Event - Any Variation	1 (read)	06 (no range, or all) 07, 08 (limited qty)		
32	1	Analog Input Event - 32-bit without time	1 (read)	06 (no range, or all) 07, 08 (limited qty)	129 (response) 130 (unsol. resp)	17, 28 (index)
32	2	Analog Input Event - 16-bit without time	1 (read)	06 (no range, or all) 07, 08 (limited qty)	129 (response) 130 (unsol. resp)	17, 28 (index)
32	3	Analog Input Event - 32-bit with time	1 (read)	06 (no range, or all) 07, 08 (limited qty)	129 (response) 130 (unsol. resp)	17, 28 (index)
32	4	Analog Input Event - 16-bit with time	1 (read)	06 (no range, or all) 07, 08 (limited qty)	129 (response) 130 (unsol. resp)	17, 28 (index)
32	5	Analog Input Event - Single-prec flt-pt without time	1 (read)	06 (no range, or all) 07, 08 (limited qty)	129 (response) 130 (unsol. resp)	17, 28 (index)
32	7	Analog Input Event - Single-prec flt-pt with time	1 (read)	06 (no range, or all) 07, 08 (limited qty)	129 (response) 130 (unsol. resp)	17, 28 (index)
40	0	Analog Output Status - Any Variation	1 (read)	00, 01 (start-stop) 06 (no range, or all)		

Implementation Table for Series B and Series C controllers

DNP Object Group & Variation			Request DNP3 Master may issue MicroLogix 1400 must parse		Response DNP3 Master must parse MicroLogix 1400 may issue	
Group Num	Var Num	Description	Function Codes (dec)	Qualifier Codes (hex)	Function Codes (dec)	Qualifier Codes (hex)
40	1	Analog Output Status - 32-bit with flag	1 (read)	00, 01 (start-stop) 06 (no range, or all)	129 (response)	00, 01 (start-stop)
40	2	Analog Output Status - 16-bit with flag	1 (read)	00, 01 (start-stop) 06 (no range, or all)	129 (response)	00, 01 (start-stop)
40	3	Analog Output Status - Single-prec flt-pt with flag	1 (read)	00, 01 (start-stop) 06 (no range, or all)	129 (response)	00, 01 (start-stop)
41	1	Analog Output - 32-bit	3 (select) 4 (operate) 5 (direct op) 6 (dir. op, no ack)	17, 27, 28 (index)	129 (response)	echo of request
41	2	Analog Output - 16-bit	3 (select) 4 (operate) 5 (direct op) 6 (dir. op, no ack)	17, 27, 28 (index)	129 (response)	echo of request
41	3	Analog Output - Single-prec flt-pt	3 (select) 4 (operate) 5 (direct op) 6 (dir. op, no ack)	17, 27, 28 (index)	129 (response)	echo of request
50	1	Time and Date - Absolute time	1 (read)	07 (limited qty = 1)	129 (response)	07 (limited qty) (qty = 1)
			2 (write)	07 (limited qty = 1)		
50	3	Time and Date - Absolute time at last recorded time	2 (write)	07 (limited qty = 1)		
51	1	Time and Date CTO - Absolute time, synchronized			129 (response) 130 (unsol. resp)	07 (limited qty) (qty = 1)
51	2	Time and Date CTO - Absolute time, unsynchronized			129 (response) 130 (unsol. resp)	07 (limited qty) (qty = 1)
52	2	Time Delay - Fine			129 (response)	07 (limited qty) (qty = 1)
60	1	Class Objects - Class 0 data	1 (read)	06 (no range, or all)		
60	2	Class Objects - Class 1 data	1 (read)	06 (no range, or all) 07, 08 (limited qty)		
			20 (enbl. unsol.) 21 (dab. unsol.)	06 (no range, or all)		
60	3	Class Objects - Class 2 data	1 (read)	06 (no range, or all) 07, 08 (limited qty)		
60	4	Class Objects - Class 3 data	1 (read)	06 (no range, or all) 07, 08 (limited qty)		
			20 (enbl. unsol.) 21 (dab. unsol.)	06 (no range, or all)		
70	2	File-Control - authentication	29 (authenticate file)	5B (free format)	129 (response)	5B (free format)
70	3	File Control - file command	25 (open file)	5B (free format)		
70	3	File Control - file command	27 (delete file)	5B (free format)		
70	4	File Control - file command status	26 (close file)	5B (free format)	129 (response)	5B (free format)

Implementation Table for Series B and Series C controllers

DNP Object Group & Variation			Request DNP3 Master may issue MicroLogix 1400 must parse		Response DNP3 Master must parse MicroLogix 1400 may issue	
Group Num	Var Num	Description	Function Codes (dec)	Qualifier Codes (hex)	Function Codes (dec)	Qualifier Codes (hex)
70	4	File Control - file command status	30 (abort file)	5B (free format)	129 (response)	5B (free format)
70	5	File Control - file transport	1 (read file)	5B (free format)	129 (response)	5B (free format)
70	5	File Control - file transport	2 (write file)	5B (free format)	129 (response)	5B (free format)
70	6	File Control - file transport status			129 (response)	5B (free format)
70	7	File-Control - file descriptor	28 (get file info)	5B (free format)	129 (response)	5B (free format)
70	8	File-Control - file specification string	31 (activate config)	5B (free format)		
80	1	Internal Indications - Packed format	1 (read)	00, 01 (start-stop)	129 (response)	00, 01 (start-stop)
			2 (write)	00 (start-stop) index=7		
85	0	Data Set Prototype	1 (read)	06 (no range, or all)		
85	1	Data Set Prototype	1 (read)	00, 01 (start-stop) 06 (no range, or all) 17, 28 (index)	129 (response)	5B (free format)
86	1	Data Set Descriptor - Contents	1 (read)	00, 01 (start-stop) 06 (no range, or all) 17, 28 (index)	129 (response)	5B (free format)
86	2	Data Set Descriptor - Characteristics	1 (read)	00, 01 (start-stop) 06 (no range, or all) 17, 28 (index)	129 (response)	5B (free format)
87	0	Data Set - Present Value	1 (read)	00, 01 (start-stop) 06 (no range, or all) 17, 28 (index)		
87	1	Data Set - Present Value	1 (read)	00, 01 (start-stop) 06 (no range, or all) 17, 28 (index)	129 (response)	5B (free format)
88	0	Data Set Event	1 (read)	06 (no range, or all) 07, 08 (limited qty)		
88	1	Data Set Event - Snapshot	1 (read)	06 (no range, or all) 07, 08 (limited qty)	129 (response) 130 (unsol. resp)	5B (free format)
90	1	Application - Identifier	16 (init. appl.) 17 (start appl.) 18 (stop appl.)	06 (no range, or all) 5B (free format)		
91	1	Status of Requested Operation			129 (response)	07 (limited qty) (qty = 1)
101	0	Binary Coded Decimal Integers - Any Variation	1 (read)	06 (no range, or all)		
101	1	Binary Coded Decimal Integers - small	1 (read)	06 (no range, or all)	129 (response)	00, 01 (start-stop)
					130 (unsol. resp)	17, 28 (index)
120	1	Authentication - Challenge	32 (Auth Request)	5B (free format)	131 (Auth. resp)	5B (free format)
120	2	Authentication - Reply	32 (Auth Request)	5B (free format)	131 (Auth. resp)	5B (free format)

Implementation Table for Series B and Series C controllers

DNP Object Group & Variation			Request DNP3 Master may issue MicroLogix 1400 must parse		Response DNP3 Master must parse MicroLogix 1400 may issue	
Group Num	Var Num	Description	Function Codes (dec)	Qualifier Codes (hex)	Function Codes (dec)	Qualifier Codes (hex)
120	3	Authentication - Aggressive Mode Request	Any requests	07 (limited qty)	129 (response)	07 (limited qty)
120	3	Authentication - Aggressive Mode Request			130 (unsol. resp)	07 (limited qty)
120	4	Authentication - Session Key Status Request	32 (Auth Request)	07 (limited qty)		
120	5	Authentication - Session Key Status			131 (Auth. resp)	5B (free format)
120	6	Authentication - Session Key Change	32 (Auth Request)	5B (free format)		
120	7	Authentication - Error	33 (Auth Request, no ack)	5B (free format)	131 (Auth. resp)	5B (free format)
120	7	Authentication - Error	1 (read)	06 (no range, or all)	129 (response)	5B (free format)
120	9	Authentication - HMAC	Any requests	5B (free format)	129 (response)	5B (free format)
120	9	Authentication - HMAC			130 (unsol. resp)	5B (free format)
No Object (function code only)			13 (cold restart)			
No Object (function code only)			14 (warm restart)			
No Object (function code only)			23 (delay meas.)			
No Object (function code only)			24 (record current time)			

Connecting to Networks via Ethernet Interface

This appendix:

- describes MicroLogix 1400 controllers and Ethernet communication.
- describes MicroLogix 1400 performance considerations.
- describes Ethernet network connections and media.
- explains how the MicroLogix 1400 establishes node connections.
- lists Ethernet configuration parameters and procedures.
- describes configuration for subnet masks and gateways.

MicroLogix 1400 Controllers and Ethernet Communication

Ethernet is a local area network that provides communication between various devices @ 10...100 Mbps. The physical communication media options for the MicroLogix 1400 are:

- built-in
 - twisted-pair (10/100Base-T)
- with media converters or hubs
 - fiber optic
 - broadband
 - thick-wire coaxial cable (10Base-5)
 - thin-wire coaxial cable (10Base-2)

See the following page for more information on Ethernet physical media.

The MicroLogix 1400 supports Ethernet communication via the Ethernet communication channel 1 shown in the drawing below.

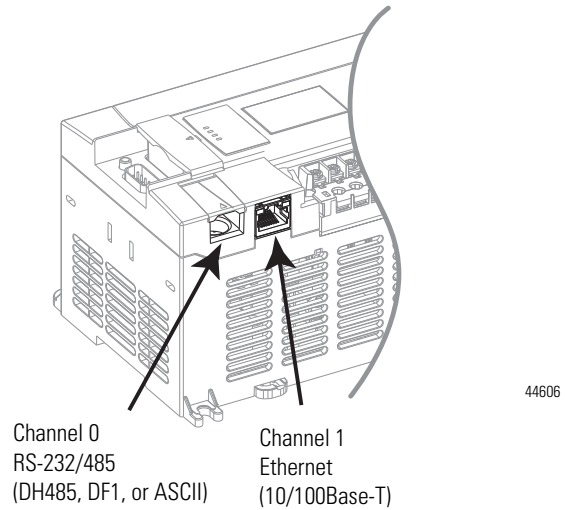

MicroLogix 1400 Performance Considerations

Actual performance of an MicroLogix 1400 controller varies according to:

- size of Ethernet messages.
- frequency of Ethernet messages.
- network loading.
- the implementation of and performance of your processor application program.

Optimal Performance: Micrologix 1400 controller to Micrologix 1100 Series B and Series C OS FRN 4 controller (2-node Ethernet network)

Operation	Words	MSG per Second	Words per Second
Single Typed Read	1	20	20
Single Typed Reads	20	20	400
Single Typed Reads	100	20	2000

Optimal Performance: MicroLogix 1400 controller to RSLinx

Operation	Words	MSG per Second	Words per Second
Single Typed Read	1	25	25
Single Typed Reads	20	25	500
Single Typed Reads	100	25	2,500

Optimal Performance: MicroLogix 1400 to MicroLogix 1400 controller

Operation	Words	MSG per Second	Words per Second
Single Typed Read	1	20	20
Single Typed Reads	20	20	400
Single Typed Reads	100	20	2,000

MicroLogix 1400 and PC Connections to the Ethernet Network

The MicroLogix 1400 Ethernet connector conforms to ISO/IEC 8802-3 STD 802.3 and utilizes 10/100Base-T media. Connections are made directly from the MicroLogix 1400 to an Ethernet hub or switch. The network setup is simple and cost effective. Typical network topology is pictured below.

Ethernet Network Topology

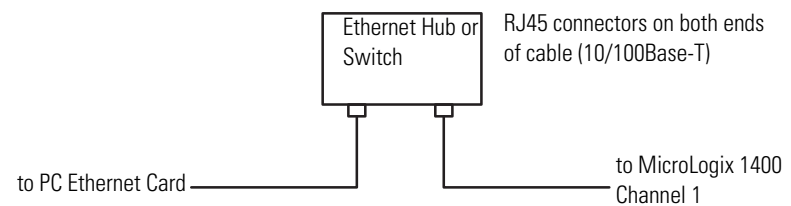
**IMPORTANT**

The MicroLogix 1400 controller contains a 10/100Base-T, RJ45 Ethernet connector which connects to standard Ethernet hubs or switches via 8-wire twisted-pair straight-through cable. To access other Ethernet mediums, use 10/100Base-T media converters or Ethernet hubs or switches that can be connected together via fiber, thin-wire, or thick-wire coaxial cables, or any other physical media commercially available with Ethernet hubs or switches.

Connecting an Ethernet switch on the Ethernet Network

The MicroLogix 1400 Ethernet port supports the following Ethernet settings:

- 10 Mbps half duplex or full duplex
- 100 Mbps half duplex or full duplex

Mode selection can be automatic, based on the IEEE 802.3 auto negotiation protocol. In most cases, using the auto negotiation function results in proper operation between a switch port and MicroLogix 1400 Ethernet port.

With RSLogix500/RSLogix Micro programming software version 8.10.00 or later, you can manually set the communication rate and duplex mode of an Ethernet port you have connected to the switch port. The settings of the Ethernet port and the switch port must match.

IMPORTANT

When connecting the MicroLogix 1400 Ethernet port to a 10/100Base-T Ethernet switch, note the following recommendations:

- Use the auto negotiation function for both the switch port and the MicroLogix 1400 Ethernet port
- If you want to force to a specific speed/duplex mode, you must force both the MicroLogix 1400 Ethernet port and the switch port to the same setting.

Cables

Shielded and non-shielded twisted-pair 10/100Base-T cables with RJ45 connectors are supported. The maximum cable length between an MicroLogix 1400 Ethernet port and a 10/100Base-T port on an Ethernet hub or switch (without repeaters or fiber) is 100 m (323 ft). However, in an industrial application, cable length should be kept to a minimum.

TIP

The Ethernet cabling with straight-through method is recommended as below. Do *not* make the incorrect connection.

Straight-through cabling

Pin	Pin Name	Cable color
1	Tx+	Orange/White
2	Tx-	Orange
3	Rx+	Green/White
4	No used by 10/100Base-T	Blue
5	No used by 10/100Base-T	Blue/White
6	Rx-	Green
7	No used by 10/100Base-T	Brown/White
8	No used by 10/100Base-T	Brown

The standard Ethernet cable is terminated in accordance with EIA/TIA 568B on both ends. The crossover cable is terminated to EIA/TIA 568B at one end and EIA/TIA 568A at the other, exactly as shown in the two color coded plugs below.

The following figures show how the TIA/EIA 568A and 568B are to be terminated. There are four pairs of wires contained in a CAT5 UTP cable. These pairs of cables are color coded white blue/blue, white orange/orange, white

green/green, white brown/brown, they are also numbered one to four in the order shown.

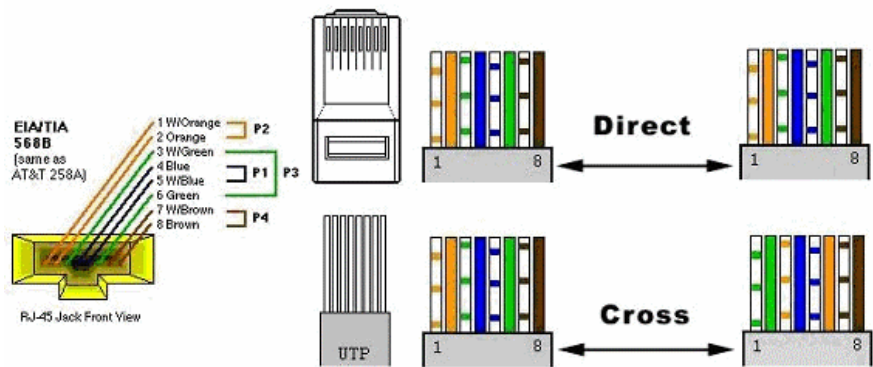
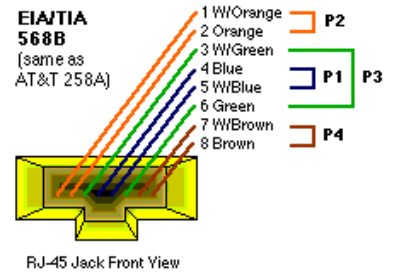
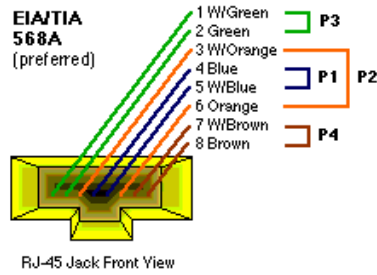

TIP

The most common wiring for RJ45 cables is the "straight through" cable which means that pin 1 of the plug on one end is connected to pin 1 of the plug on the other end. The straight through RJ45 cable is commonly used to connect network cards with hubs on 10Base-T and 100Base-Tx networks. On network cards, pair 1-2 is the transmitter, and pair 3-6 is the receiver. The other two pairs are not used. On hubs pair 1-2 is the receiver and 3-6 the transmitter. It may be best to wire your cables with the same color sequence. In this cable layout, all pins are wired one-to-one to the other side. The pins on the RJ45 connector are assigned in pairs, and every pair carries one differential signal. Each line pair has to be twisted.

In small networks where only two Ethernet devices need to be connected together point-to-point, a "cross over" RJ45 cable may be necessary, where the transmit and receive lines on both RJ45 connectors are cross connected. The color coding for the cross over RJ45 cable have been defined in the EIA/TIA 568A standard. In a cross-over cable layout, you should remember that one end is normal, and the other end has the cross-over configuration.

However, because the MicroLogix 1400 Ethernet port implements "auto-crossover" (also called Automatic MDI/MDI-X Configuration), a straight through cable may be used even for direct point-to-point connections between the MicroLogix 1400 and another Ethernet device.

Ethernet Connections

TCP/IP is the mechanism used to transport Ethernet messages. On top of TCP, Ethernet/IP and/or Modbus TCP protocol is required to establish sessions and to send the MSG commands. Connections can be initiated by either a client program (RSLinx application) or a processor.

The client program or processor must first establish a connection to the MicroLogix 1400 to enable the MicroLogix 1400 to receive solicited messages from a client program or another processor.

In order to *send* an outgoing message, the MicroLogix 1400 must first establish a connection with the destination node at a specified IP address on the Ethernet network. A connection is established when a MSG instruction executes and no previous connection exists.

When a MSG instruction executes, the MicroLogix 1400 checks to see whether a connection has been established with the destination node. If a connection has not been established, the MicroLogix 1400 attempts to establish a connection of the peer type.

In order to *receive* messages from another device on Ethernet, an "incoming" connection must be established. This incoming connection is made by the sending processor and uses one incoming connection in the receiving processor.

The MicroLogix 1400 supports a maximum of 32 EtherNet/IP connections and 32 Modbus TCP connections, allowing a maximum of 32 outgoing and a maximum of 32 incoming simultaneous connections with up to 64 other devices or applications.. The connections are dedicated as follows:

Number of Connections⁽¹⁾	Dedicated to:
16	Incoming EtherNet/IP Connections
16 (Series B and Series C only)	Incoming Modbus TCP Connections
16	Outgoing EtherNet/IP Connections
16 (Series B and Series C only)	Outgoing Modbus TCP Connections

⁽¹⁾ Connections established by an INTERCHANGE™ client, RSLinx client, and peers are all included when counting the number of connections.

IMPORTANT For outgoing connections, no more that one connection per destination node is established. If multiple MSG instructions use the same destination node, they share the same connection.

Duplicate IP address Detection

The MicroLogix 1400 firmware supports duplicate IP address detection. In Series B and Series C, duplicate IP address detection can be disabled in the Channel 1 configuration in order to eliminate this source of broadcast traffic for low bandwidth applications.

When you change the IP address or connect one of the MicroLogix to an EtherNet/IP network, the MicroLogix 1400 controller checks to make sure that the IP address assigned to this device does not match the address of any other network device. The MicroLogix 1400 will check every 2 minutes for a duplicate IP address on the network. If the MicroLogix 1400 determines that there is a conflict (another device on the network with a matching IP address), the following message gets posted on the LCD display.

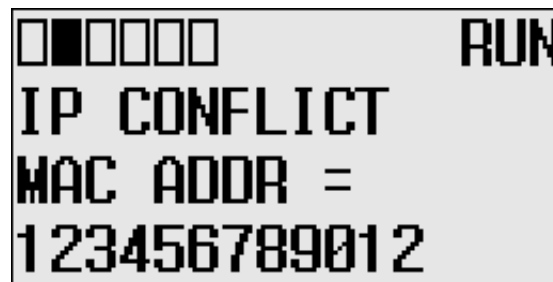

To correct this conflict, use the instructions in this chapter to change the IP address of the Ethernet/IP device. Then cycle power to the device or reset the device (such as disconnecting the ethernet cable and reconnecting the cable). There is also the possibility that two Ethernet/IP device can detect a conflict simultaneously. If this occurs, remove the device with the incorrect IP address or correct its conflict. To get the second device out of conflict mode, cycle power to the module or disconnect its ethernet cable and reconnect the cable.

The MicroLogix 1400 will check every 2 minutes for a duplicate IP address on the network.

Configuring the Ethernet Channel on the MicroLogix 1400

There are three ways to configure the MicroLogix 1400 Ethernet channel 1.

- via a BOOTP or DHCP request at controller powerup
- manually setting the configuration parameters using RSLogix 500/RSLogix Micro Programming Software
- via LCD display (see [Configuring the Ethernet Port on page 142](#) and [Configuring Ethernet Protocol Setup on page 145](#))

The configuration parameters are shown on the following page, and the configuration procedures follow.

Configuration Parameters

Parameter	Description	Default	Status
Hardware Address	The MicroLogix 1400 Ethernet hardware address.	Ethernet hardware address	read only
IP Address	The MicroLogix 1400 internet address (in network byte order). The internet address must be specified to connect to the TCP/IP network.	0 (undefined)	read/write
Subnet Mask	The MicroLogix 1400 subnet mask (in network byte order). The Subnet Mask is used to interpret IP addresses when the internet is divided into subnets. A Subnet Mask of all zeros indicates that no subnet mask has been configured. In this case, the controller assumes a Subnet Mask of 255.255.255.0.	0 (undefined)	read/write
Gateway Address	The address of a gateway (in network byte order) that provides connection to another IP network. A Gateway Address of all zeros indicates that no gateway has been configured. In this case, the controller assumes a Gateway Address of aaa.bbb.ccc.001, where aaa.bbb.ccc are the first three octets of the configured IP Address.	0 (undefined)	read/write
Default Domain Name	The default domain name can have the following formats: 'a.b.c', 'a.b' or 'a', where a, b, c must start with a letter, end with a letter or digit, and have as interior characters only letters, digits or hyphens. Maximum length is 63 characters.	NULL (undefined)	read/write
Primary Name Server	This is the IP address of the computer acting as the local Ethernet network Primary Domain Name System (DNS) server.	0 (undefined)	read/write
Secondary Name Server	This is the IP address of the computer acting as the local Ethernet network Secondary Domain Name System (DNS) server.	0 (undefined)	read/write
BOOTP Enable	The BOOTP enable switch. When BOOTP is enabled, the MicroLogix 1400 attempts to learn its network related parameters at powerup via a BOOTP request. There must be a BOOTP server on the network capable of responding to this BOOTP request. When both BOOTP and DHCP are disabled, the MicroLogix 1400 uses the locally configured network related parameters (IP Address, Subnet Mask, Broadcast Address, etc.).	1 (enabled)	read/write
DHCP Enable	The DHCP auto configuration enable switch. When DHCP is enabled, a DHCP server automatically assigns network related parameters to the MicroLogix 1400 when it logs into a TCP/IP network. There must be a DHCP server on the network capable of allocating network addresses and configuring parameters to newly attached device. When both BOOTP and DHCP are disabled, the MicroLogix 1400 uses the locally configured network related parameters (IP Address, Subnet Mask, Broadcast Address, etc.).	0 (disabled)	read/write
SNMP Server Enable	SNMP enable switch. Check this to enable SNMP (Simple Network Management Protocol).	1 (enabled)	read/write
SMTP Client Enable	The SMTP Client service enable switch. When SMTP is enabled, MicroLogix 1400 is capable of transmitting e-mail messages generated by a 485CIF write message with a string element. There must be a SMTP server on the network capable of processing e-mail service. This provides an extremely versatile mechanism to report alarms, status, and other data-related functions.	0 (disabled)	read/write
Auto Negotiate and Port Setting	When Auto Negotiate is disabled (unchecked), the Ethernet speed/duplex is forced to either 10 Mbps/Half-duplex, 10 Mbps/Full-duplex, 100 Mbps/Half-duplex, or 100 Mbps/Full-duplex, as selected in the Port Setting field. When Auto Negotiate is enabled (checked), the Port Setting Field allows you to select the range of speed/duplex settings that the MicroLogix 1400 will negotiate.	Auto Negotiate enabled and Port Setting. 10/100 Mbps Full Duplex/Half Duplex	read/write
MSG Connection Timeout	The amount of time (in ms) allowed for a MSG instruction to establish a connection with the destination node. The MSG Connection Timeout has 250 ms resolution and a range from 250 to 65,500.	15,000 ms	read/write
MSG Reply Timeout	The amount of time (in ms) that the MicroLogix 1400 will wait for a reply to a command that it has initiated via a MSG instruction. The MSG Reply Timeout has 250 ms resolution and a range from 250...65,500.	3,000 ms	read/write
Inactivity Timeout	The amount of time (in minutes) that a MSG connection may remain inactive before it is terminated. The Inactivity Timeout has a 1 minute resolution and a range from 1...65,500 minutes.	30 minutes.	read/write

Configuration Parameters

Parameter	Description	Default	Status
Contact	The Contact string which is specified by the SNMP client. The maximum length is 63 characters.		read only
Location	The Location string which is specified by the SNMP client. The maximum length is 63 characters.		read only
Network Link ID	The Link ID assigned to the MicroLogix 1400 by either an RSLinx OPC topic or by the routing table in a 1756-DHRIO or 1756-DH485 module. The range is 0...199.	0	read/write
Starting Data File Number	The first ASCII (A) file number in a contiguous block of 4-32 ASCII files (4 per User Provided Web Page). The range is 9...252 (or 0 for disable).	0	read/write
Number of Pages	The number of User Provided Web Pages, provided the Starting Data File Number is non-zero. The range is 1...8.	1	read/write
DNP3 over IP Enable	When DNP3 over IP is enabled (checked), the MicroLogix 1400 enables DNP3 over IP feature on Ethernet channel. Power cycle is required for changes to take effect.	0 (disable)	read/write
Modbus TCP Enable	When Modbus TCP is enabled (checked), the MicroLogix 1400 enables Modbus TCP feature on Ethernet channel. Power cycle is required for changes to take effect.	0 (disable)	read/write
Disable EtherNet/IP Incoming Connections	When EtherNet/IP Incoming Connections is disabled (checked), the MicroLogix 1400 does not allow the incoming EtherNet/IP connection. However, MicroLogix 1400 can send the outgoing EtherNet/IP commands to other EtherNet/IP devices. Power cycle is required for changes to take effect.	0 (disable)	read/write
Disable Duplicate IP Address Detection	When Duplicate IP Address Detection is disabled (checked), the MicroLogix 1400 does not send any packets to the network to detect Duplicate IP on the same network.	0 (disable)	read/write

Configuration Using RSLogix 500/RSLogix Micro Programming Software

Refer to the online documentation provided with your programming software.

Configuration Via BOOTP

BOOTP (bootstrap protocol) is a low-level protocol that TCP/IP nodes use to obtain start-up information. By default, the MicroLogix 1400 broadcasts BOOTP requests at powerup. The BOOTP Valid parameter remains clear until a BOOTP reply has been received. BOOTP lets you dynamically assign IP Addresses to processors on the Ethernet Link.

To use BOOTP, a BOOTP Server must exist on the local Ethernet subnet. The server is a computer that has BOOTP Server software installed and reads a text file containing network information for individual nodes on the network.

The host system's BOOTP configuration file must be updated to service requests from MicroLogix 1400 controllers. The following parameters must be configured:

Configuration Parameters

Parameter	Description
IP Address	A unique IP Address for the MicroLogix 1400 controller.
Subnet Mask	Specifies the net and local subnet mask as per the standard on subnetting RFC 950, Internet Standard Subnetting Procedure.
Gateway	Specifies the IP address of a gateway on the same subnet as the MicroLogix 1400 that provides connections to another IP network.

TIP You can use any commercially available BOOTP server. If you do not have BOOTP Server capabilities on your network, and you want to dynamically configure Channel 1, you can download the free Rockwell Automation BOOTP server from the Rockwell Automation website. Go to <http://www.ab.com/networks/ethernet/bootp.html>.

When BOOTP is enabled, the following events occur at power-up:

- The processor broadcasts a BOOTP-request message containing its hardware address over the local network or subnet.
- The BOOTP server compares the hardware address with the addresses in its look-up table.
- The BOOTP server sends a message back to the processor with the IP address and other network information that corresponds to the hardware address it received.

With all hardware and IP addresses in one location, you can easily change IP addresses in the BOOTP configuration file if your network needs to be changed.

The BOOTP request can be disabled by clearing the BOOTP Enable parameter in the channel configuration file. When both BOOTP Enable and DHCP are cleared (disabled), the MicroLogix 1400 uses the existing channel configuration data.

IMPORTANT If BOOTP is disabled, or no BOOTP server exists on the network, you must use RSLogix 500/RSLogix Micro programming software to enter/change the IP address for each processor or you must use DHCP instead of it.

Using the Rockwell Automation BOOTP/DHCP Utility

The Rockwell Automation BOOTP/DHCP server utility is a standalone program that incorporates the functionality of standard BOOTP software with a user-friendly graphical interface. It is located in the **Utils** directory on the RSLogix 500/RSLogix Micro installation CD.

The newest version of the utility can be downloaded from <http://www.ab.com/networks/ethernet/bootp.html>. The device must have BOOTP enabled (factory default) or DHCP enabled to use the utility.

To configure your device using the BOOTP utility, perform the following steps.

1. Run the BOOTP/DHCP server utility software. It will ask you to configure your network settings before using the BOOTP/DHCP server tool. Enter your Ethernet settings for Subnet Mask and Gateway. If you are not sure about it, get a help from your system administrator. Just leave Primary DNS, Secondary DNS, and Domain Name (If corresponding information is allocated to the PC where BOOTP/DHCP server utility is installed, enter the same information.)

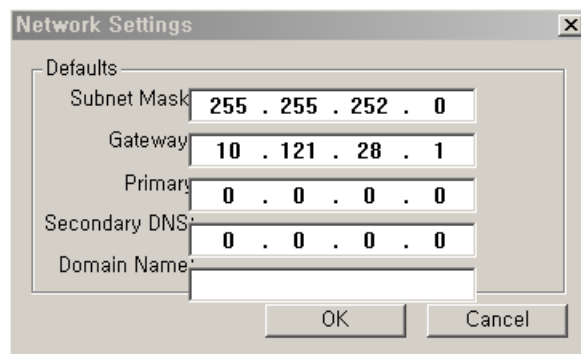

2. In the **Request History** panel you will see the hardware addresses of devices issuing BOOTP or DHCP requests.

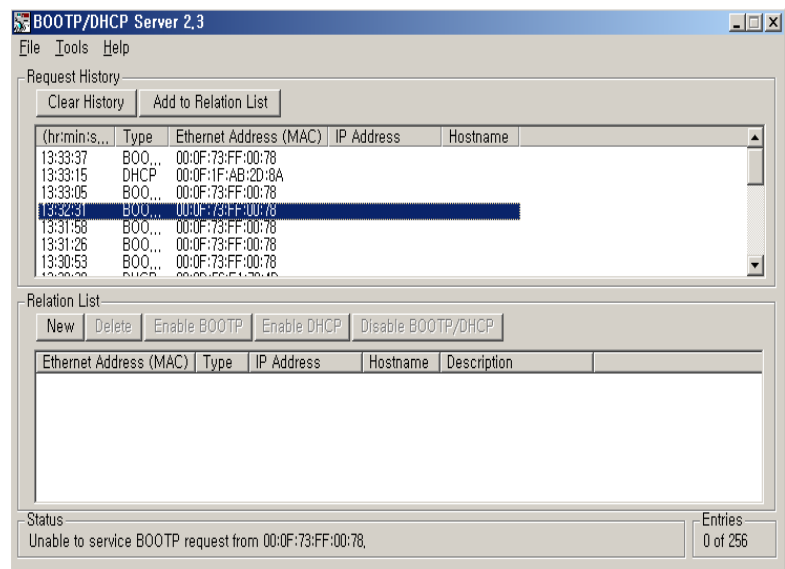

- Double-click on the hardware address of the device you want to configure. You will see the **New Entry** pop-up window with the device's Ethernet Address (MAC).

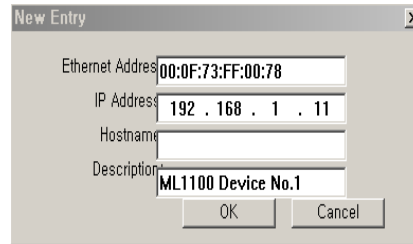

- Enter the **IP Address and Description** you want to assign to the device, and click **OK**. Leave Hostname blank.

The device will be added to the **Relation List**, displaying the Ethernet Address (MAC) and corresponding IP Address, Subnet Mask, and Gateway (if applicable).

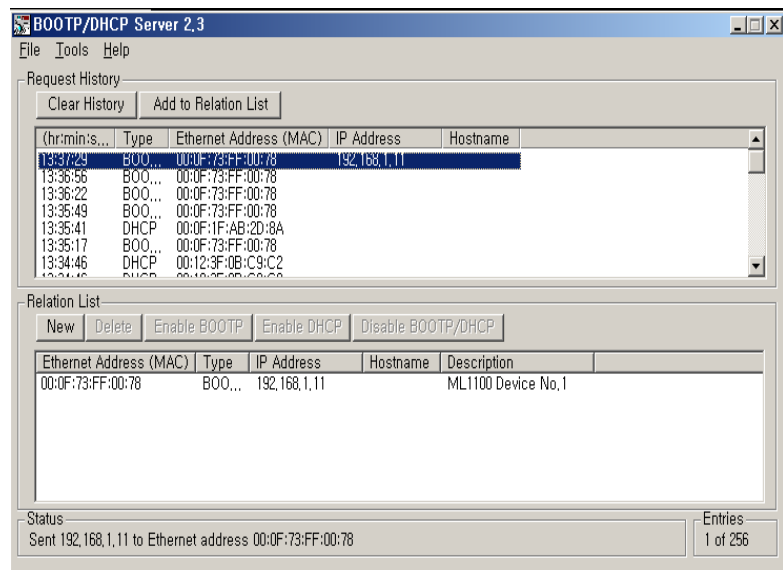

Using a DHCP Server To Configure Your Processor

A DHCP server automatically assigns IP addresses to client stations logging onto a TCP/IP network. DHCP is based on BOOTP and maintains some backward compatibility. The main difference is that BOOTP was designed for manual configuration, while DHCP allows for dynamic allocation of network addresses and configurations to newly attached devices.



ATTENTION: The processor must be assigned a fixed network address. The IP address of the processor must not be dynamically provided. *Failure to observe this precaution may result in unintended machine motion or loss of process control.*

Using Subnet Masks and Gateways

Configure subnet masks and gateways using the Ethernet channel 1 configuration screen.

IMPORTANT If BOOTP is enabled, you can't change any of the advanced Ethernet communications characteristics.

If your network is divided into subnetworks that use gateways or routers, you must indicate the following information when configuring channel 1:

- subnet mask
- gateway address

A *subnet mask* is a filter that a node applies to IP addresses to determine if an address is on the local subnet or on another subnet. If an address is located on another subnetwork, messages are routed through a local gateway to be transferred to the destination subnetwork.

If your network is not divided into subnets, then leave the subnet mask field at the default.

If you are	Then
manually configuring channel 1 and have a network with subnets	<ul style="list-style-type: none"> • be sure the BOOTP enable field is disabled • use your programming software to enter the subnet mask and gateway address.
using BOOTP to configure channel 1 and have a network with subnets	<ul style="list-style-type: none"> • be sure BOOTP is enabled • include the subnet mask(s) and gateway address(es)

Manually Configuring Channel 1 for Controllers on Subnets

If you are manually configuring channel 1 for a MicroLogix 1400 controller located on a subnet, deselect both of the “BOOTP Enable” and “DHCP Enable” options by clicking on the checked box, as shown in the figure below.

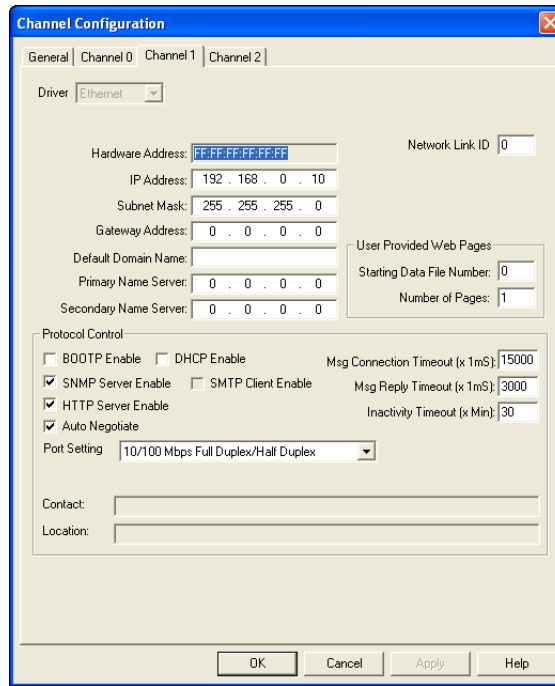

See the table below to configure the subnet mask and gateway address fields for each controller via your programming software.

This field:	Specifies:	Configure by doing the following:
Subnet Mask	The controller’s subnet mask. The subnet mask is used to interpret IP addresses when the internet is divided into subnets.	Enter an address of the following form: a.b.c.d Where: a, b, c, d are between 0..255 (decimal) If your network is not divided into subnets, then leave the subnet mask field at the default. If you change the default and need to reset it, type 0.0.0.0.
Gateway Address	The IP address of the gateway that provides a connection to another IP network. This field is required when you communicate with other devices not on a local subnet.	Enter an address of the following form: a.b.c.d Where: a, b, c, d are between 0..255 (decimal) The default address is No Gateway.

MicroLogix 1400 Embedded Web Server Capability

MicroLogix 1400 controllers include not only the embedded web server which allows viewing of module information, TCP/IP configuration, and diagnostic information, but the capabilities that also allow viewing of the data file via Ethernet using a standard web browser.

For more information on MicroLogix 1400 embedded web server capability, refer to the MicroLogix 1400 Embedded Web Server User Manual, publication [1766-UM002](#).

Disable the Ethernet Channel

Disable the Ethernet channel by performing the following steps:

1. From the status file, set the status bit S:36/0 from 0 to 1.

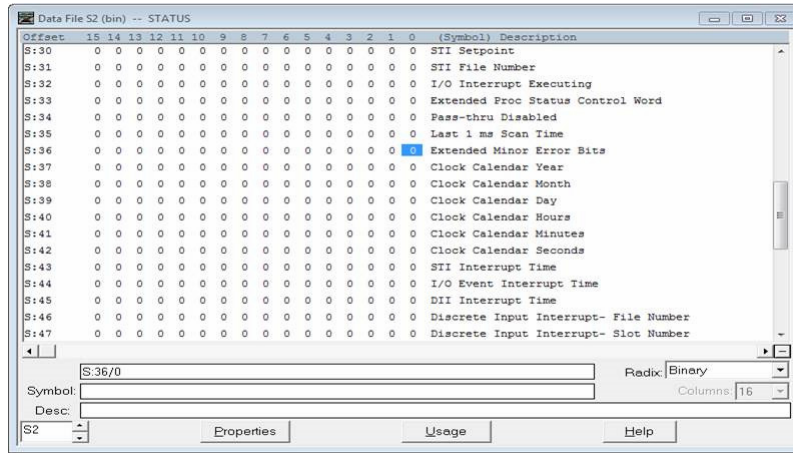

IMPORTANT You can only change the status bit S:36/0 in an offline project.

2. Download the project to the MicroLogix 1400 controller.
3. Perform a power cycle in order for the changes to take effect.

IMPORTANT Consider the following when you enable or disable the Ethernet channel using the status bit S:36/0:

- To enable or disable the Ethernet channel, a power cycle on the controller is required for the change of status to take effect.
- If the Ethernet channel is set to disable, the other Ethernet-related protocols must also be set to disable (except for BOOTP as it returns to enable mode even if you set it to disable), in order for the user project to download successfully.
- If the Ethernet channel is in disable mode (after a power cycle), you cannot set the Ethernet channel and the other Ethernet-related protocols (except for BOOTP) back to enable mode at the same time. To do this, you need to set the Ethernet channel to enable and perform a power cycle on the controller first before you can enable the other Ethernet-related protocols.
- If the Ethernet channel is disabled and you configured the MSG instruction for channel 1, the instruction indicates an error as the channel is shut down during RUN mode.

IMPORTANT At least 1 of the 3 channels must be active to enable communication with the RSLogix 500 software. You cannot disable the Ethernet channel if both serial channels are already configured as disabled. If you attempt to change the status bit S:36/0 from 0 to 1, it reverts to enable (0) after the power cycle.

See also [Appendix F](#) for information on how to disable the Incoming EtherNet/IP Connections.

System Loading and Heat Dissipation

TIP A maximum of seven 1762 I/O modules, in *any* combination, can be connected to a MicroLogix 1400 controller. You can use this appendix to determine the power supply load and heat dissipation for your system.

System Loading Calculations

The MicroLogix 1400 controller is designed to support up to any seven 1762 expansion I/O modules.

When you connect MicroLogix accessories and expansion I/O, an electrical load is placed on the controller power supply. This section shows how to calculate the load of your control system.

The following example is provided to illustrate system loading calculation. The system calculation procedure accounts for the amount of 5V DC and 24V DC current consumed by controller, expansion I/O, and user-supplied equipment. Use the [System Loading Worksheet on page 401](#) to calculate your controller configuration.

System Loading Example Calculations

Current Loading

Calculating the Current for Expansion I/O

Catalog Number ⁽¹⁾	n	A	B	n x A	n x B
	Number of Modules	Device Current Requirements (max)		Calculated Current	
		at 5V DC (mA)	at 24V DC (mA)	at 5V DC (mA)	at 24V DC (mA)
1762-IA8	2	50	0	100	0
1762-IF4		40	50		
1762-IF20F2		40	105		
1762-IQ8		50	0		
1762-IQ16		70 ⁽²⁾	0		
1762-IQ32T		170	0		
1762-IR4		40	50		
1762-IT4		40	50		
1762-OA8		115	0		
1762-OB8		115	0		
1762-OB16		175	0		
1762-OB32T		175	0		
1762-OF4		40	165		
1762-OV32T		175	0		
1762-OW8	2	80	90	160	180
1762-OW16		140 ⁽²⁾	180 ⁽²⁾		
1762-OX6I		110	110		
1762-IQ8OW6		110	80		
Total Modules (7 maximum):	4	Subtotal:		260	180

(1) Refer to your expansion I/O Installation Instructions for Current Requirements not listed in this table.

(2) Only applicable to Series B and Series C I/O modules.

Validating the System

The example systems shown in the tables below are verified to be acceptable configurations. The systems are valid because:

- *Calculated Current Values < Maximum Allowable Current Values*
- *Calculated System Loading < Maximum Allowable System Loading*

Validating Systems using 1766-L32AWA, or 1766-L32BXB

Maximum Allowable Values		Calculated Values	
Current:		Current (Subtotal from Table on page 400.):	
1225 mA @ 5V DC	1155 mA @ 24V DC	0 mA + 260 mA = 260 mA @ 5V DC	0 mA + 180 mA = 180 mA @ 24V DC
System Loading:		System Loading:	
33.845 W		$= (260 \text{ mA} \times 5\text{V}) + (180 \text{ mA} \times 24\text{V})$ $= (1,300 \text{ mW}) + (4,320 \text{ mW})$ $= 5,620 \text{ mW}$ $= 5.62 \text{ W}$	

Validating Systems using 1766-L32BWA

Maximum Allowable Values		Calculated Values	
Current for Devices Connected to the +24V DC Sensor Supply:		Sum of all sensor currents	
250 mA @ 24V DC		140 mA @ 24V DC (example sensor value)	
Current for MicroLogix Accessories and Expansion I/O:		Current Values (Subtotal from Table):	
1225 mA @ 5V DC	1155 mA @ 24V DC	0 mA + 260 mA = 260 mA @ 5V DC	0 mA + 180 mA = 180 mA @ 24V DC
System Loading:		System Loading:	
39.845 W		$= (140 \text{ mA} \times 24\text{V}) + (260 \text{ mA} \times 5\text{V}) + (180 \text{ mA} \times 24\text{V})$ $= (3,360 \text{ mW}) + (1,300 \text{ mW}) + (4,320 \text{ mW})$ $= 8,980 \text{ mW}$ $= 8.98 \text{ W}$	

System Loading Worksheet

The tables below are provided for system loading validation. See [System Loading Example Calculations on page 400](#).

Current Loading

Calculating the Current for Expansion I/O

Catalog Number ⁽¹⁾	n	A	B	n x A	n x B
	Number of Modules	Device Current Requirements		Calculated Current	
		@ 5V DC (mA)	@ 24V DC (mA)	@ 5V DC (mA)	@ 24V DC (mA)
1762-IA8		50	0		
1762-IF4		40	50		
1762-IF20F2		40	105		

Calculating the Current for Expansion I/O

1762-IQ8		50	0		
1762-IQ16		70	0		
1762-IQ32T		170	0		
1762-IR4		40	50		
1762-IT4		40	50		
1762-OA8		115	0		
1762-OB8		115	0		
1762-OB16		175	0		
1762-OB32T		175	0		
1762-OF4		40	165		
1762-OV32T		175	0		
1762-OW8		80	90		
1762-OW16		140 ⁽²⁾	180 ⁽²⁾		
1762-OX6I		110	110		
1762-IQ8OW6		110	80		
Total Modules (7 maximum):		Subtotal:			

(1) Refer to your expansion I/O Installation Instructions for Current Requirements not listed in this table.

(2) Only applicable to Series B and Series C I/O modules.

Validating Systems using 1766-L32AWA or 1766-L32BxB

Maximum Allowable Values		Calculated Values	
Current:		Current (Subtotal from Table .):	
1225 mA at 5V DC	1155 mA at 24V DC	mA @ 5V DC	mA @ 24V DC
System Loading:		System Loading:	
33.845 W		$= (\text{_____ mA} \times 5V) + (\text{_____ mA} \times 24V)$ $= \text{_____ mW} + \text{_____ mW}$ $= \text{_____ mW}$ $= \text{_____ W}$	

Validating Systems using 1766-L32BWA

Maximum Allowable Values		Calculated Values	
Current for Devices Connected to the +24V DC Sensor Supply:		Sum of all sensor currents	
250 mA @ 24V DC		mA @ 24V DC	
Current for MicroLogix Accessories and Expansion I/O:		Current (Subtotal from Table .)	
1225 mA @ 5V DC	1155 mA @ 24V DC	mA @ 5 V DC	mA @ 24V DC
System Loading:		System Loading:	
39.845 W		$= (\text{_____ mA} \times 24V) + (\text{_____ mA} \times 5V) + (\text{_____ mA} \times 24V)$ $= \text{_____ mW} + \text{_____ mW} + \text{_____ mW}$ $= \text{_____ mW}$ $= \text{_____ W}$	

Calculating Heat Dissipation

Use the following table when you need to determine the heat dissipation of your system for installation in an enclosure. For System Loading, take the value from the appropriate system loading worksheets on pages [401](#) or [403](#).

Heat Dissipation

Catalog Number	Heat Dissipation		
	Equation or Constant	Calculation	Sub-Total
1766-L32AWA	15.2 W + (0.4 x System Loading)	15.2 W + (0.4 x _____ W)	W
1766-L32BWA	15.7 W + (0.4 x System Loading)	15.7 W + (0.4 x _____ W)	W
1766-L32BxB	17.0 W + (0.3 x System Loading)	17.0 W + (0.3 x _____ W)	W
1762-IA8	2.0 W x number of modules	2.0 W x _____	W
1762-IF4	2.0 W x number of modules	2.0 W x _____	W
1762-IF20F2	2.6 W x number of modules	2.6 W x _____	W
1762-IQ8	3.7 W x number of modules	3.7 W x _____	W
1762-IQ16	5.4 W ⁽¹⁾ x number of modules	5.4 W ⁽¹⁾ x _____	W
1762-IQ32T	6.8 W x number of modules (@ 30.0V DC)	6.8 W x _____ (@ 30.0V DC)	W
	5.4 W x number of modules (@ 26.4V DC)	5.4 W x _____ (@ 26.4V DC)	W
1762-IR4	1.5 W x number of modules	1.5 W x _____	W
1762-IT4	1.5 W x number of modules	1.5 W x _____	W
1762-OA8	2.9 W x number of modules	2.9 W x _____	W

Heat Dissipation

1762-OB8	1.6 W x number of modules	1.6 W x _____	W
1762-OB16	2.9 W x number of modules	2.9 W x _____	W
1762-OB32T	3.4 W x number of modules	3.4 W x _____	W
1762-OF4	3.8 W x number of modules	3.8 W x _____	W
1762-OV32T	2.7 W x number of modules	2.7 W x _____	W
1762-OW8	2.9 W x number of modules	2.9 W x _____	W
1762-OW16	6.1 W ⁽¹⁾ x number of modules	6.1 W ⁽¹⁾ x _____	W
1762-OX6I	2.8 W x number of modules	2.8 W x _____	W
1762-IQ8OW6	4.4 W x number of modules	4.4 W x _____	W
Add Sub-Totals to determine Heat Dissipation			W

(1) Only applicable to Series B and Series C I/O modules.

The following terms are used throughout this manual. Refer to the *Allen-Bradley Industrial Automation Glossary*, publication AG-7.1, for a complete guide to Allen-Bradley technical terms.

address

A character string that uniquely identifies a memory location. For example, I:1/0 is the memory address for the data located in the Input file location word1, bit 0.

AIC+ Advanced Interface Converter

A device that provides a communication link between various networked devices. (Catalog Number 1761-NET-AIC.)

application

- 1) A machine or process monitored and controlled by a controller.
- 2) The use of computer- or processor-based routines for specific purposes.

baud rate

The speed of communication between devices. All devices must communicate at the same baud rate on a network.

bit

The smallest storage location in memory that contains either a 1 (ON) or a 0 (OFF).

block diagrams

A schematic drawing.

Boolean operators

Logical operators such as AND, OR, NAND, NOR, NOT, and Exclusive-OR that can be used singularly or in combination to form logic statements or circuits. Can have an output response of T or F.

branch

A parallel logic path within a rung of a ladder program.

communication scan

A part of the controller's operating cycle. Communication with other devices, such as software running on a personal computer, takes place.

controller

A device, such as a programmable controller, used to monitor input devices and control output devices.

controller overhead

An internal portion of the operating cycle used for housekeeping and set-up purposes.

control profile

The means by which a controller determines which outputs turn on under what conditions.

counter

- 1) An electro-mechanical relay-type device that counts the occurrence of some event. May be pulses developed from operations such as switch closures or interruptions of light beams.
- 2) In controllers, a software counter eliminates the need for hardware counters. The software counter can be given a preset count value to count up or down whenever the counted event occurs.

CPU (Central Processing Unit)

The decision-making and data storage section of a programmable controller.

data table

The part of processor memory that contains I/O values and files where data is monitored, manipulated, and changed for control purposes.

DIN rail

Manufactured according to Deutsche Industrie Normenausschuss (DIN) standards, a metal railing designed to ease installation and mounting of your controller.

download

Data is transferred from a programming or storage device to another device.

DTE (Data Terminal Equipment)

Equipment that is attached to a network to send or receive data, or both.

embedded I/O

Embedded I/O is the controller's on-board I/O.

EMI

Electromagnetic interference.

encoder

- 1) A rotary device that transmits position information.
- 2) A device that transmits a fixed number of pulses for each revolution.

executing mode

Any run or test mode.

expansion I/O

Expansion I/O is I/O that is connected to the controller via a bus or cable. MicroLogix 1400 controllers use Bulletin 1762 expansion I/O.

false

The status of an instruction that does not provide a continuous logical path on a ladder rung.

FIFO (First-In-First-Out)

The order that data is entered into and retrieved from a file.

file

A collection of information organized into one group.

full-duplex

A bidirectional mode of communication where data may be transmitted and received simultaneously (contrast with half-duplex).

half-duplex

A communication link in which data transmission is limited to one direction at a time.

hard disk

A storage area in a personal computer that may be used to save processor files and reports for future use.

high byte

Bits 8 to 15 of a word.

input device

A device, such as a push button or a switch, that supplies signals to the input circuits of the controller.

inrush current

The temporary surge current produced when a device or circuit is initially energized.

instruction

A mnemonic and data address defining an operation to be performed by the processor. A rung in a program consists of a set of input and output instructions. The input instructions are evaluated by the controller as being true or false. In turn, the controller sets the output instructions to true or false.

instruction set

The set of general purpose instructions available with a given controller.

I/O (Inputs and Outputs)

Consists of input and output devices that provide and/or receive data from the controller.

jump

Change in normal sequence of program execution, by executing an instruction that alters the program counter (sometimes called a branch). In ladder programs a JUMP (JMP) instruction causes execution to jump to a labeled rung.

ladder logic

A program written in a format resembling a ladder-like diagram. The program is used by a programmable controller to control devices.

least significant bit (LSB)

The digit (or bit) in a binary word (code) that carries the smallest value of weight.

LED (Light Emitting Diode)

Used as status indicator for processor functions and inputs and outputs.

LIFO (Last-In-First-Out)

The order that data is entered into and retrieved from a file.

low byte

Bits 0 to 7 of a word.

logic

A process of solving complex problems through the repeated use of simple functions that can be either true or false. General term for digital circuits and programmed instructions to perform required decision making and computational functions.

Master Control Relay (MCR)

A mandatory hard-wired relay that can be de-energized by any series-connected emergency stop switch. Whenever the MCR is de-energized, its contacts open to de-energize all application I/O devices.

mnemonic

A simple and easy to remember term that is used to represent a complex or lengthy set of information.

modem

Modulator/demodulator. Equipment that connects data terminal equipment to a communication line.

modes

Selected methods of operation. Example: run, test, or program.

negative logic

The use of binary logic in such a way that “0” represents the voltage level normally associated with logic 1 (for example, 0 = +5V, 1 = 0V). Positive is more conventional (for example, 1 = +5V, 0 = 0V).

network

A series of stations (nodes) connected by some type of communication medium. A network may be made up of a single link or multiple links.

nominal input current

The current at nominal input voltage.

normally closed

Contacts on a relay or switch that are closed when the relay is de-energized or the switch is deactivated; they are open when the relay is energized or the switch is activated. In ladder programming, a symbol that allows logic continuity (flow) if the referenced input is logic “0” when evaluated.

normally open

Contacts on a relay or switch that are open when the relay is de-energized or the switch is deactivated. (They are closed when the relay is energized or the switch is activated.) In ladder programming, a symbol that allows logic continuity (flow) if the referenced input is logic “1” when evaluated.

off-delay time

The OFF delay time is a measure of the time required for the controller logic to recognize that a signal has been removed from the input terminal of the controller. The time is determined by circuit component delays and by any filter adjustment applied.

offline

Describes devices not under direct communication.

offset

The steady-state deviation of a controlled variable from a fixed point.

off-state leakage current

When an ideal mechanical switch is opened (off-state) no current flows through the switch. Practical semiconductor switches, and the transient suppression components which are sometimes used to protect switches, allow a small current to flow when the switch is in the off state. This current is referred to as the off-state leakage current. To ensure reliable operation, the off-state leakage current rating of a switch should be less than the minimum operating current rating of the load that is connected to the switch.

on-delay time

The ON delay time is a measure of the time required for the controller logic to recognize that a signal has been presented at the input terminal of the controller.

one-shot

A programming technique that sets a bit for only one program scan.

online

Describes devices under direct communication. For example, when RSLogix 500/RSLogix Micro is monitoring the program file in a controller.

operating voltage

For inputs, the voltage range needed for the input to be in the On state. For outputs, the allowable range of user-supplied voltage.

output device

A device, such as a pilot light or a motor starter coil, that is controlled by the controller.

processor

A Central Processing Unit. (See CPU.)

processor file

The set of program and data files used by the controller to control output devices. Only one processor file may be stored in the controller at a time.

program file

The area within a processor file that contains the ladder logic program.

program mode

When the controller is not executing the processor file and all outputs are de-energized.

program scan

A part of the controller's operating cycle. During the scan the ladder program is executed and the output data file is updated based on the program and the input data file.

programming device

Executable programming package used to develop ladder diagrams.

protocol

The packaging of information that is transmitted across a network.

read

To acquire data from a storage place. For example, the processor READs information from the input data file to solve the ladder program.

relay

An electrically operated device that mechanically switches electrical circuits.

relay logic

A representation of the program or other logic in a form normally used for relays.

restore

To download (transfer) a program from a personal computer to a controller.

reserved bit

A status file location that the user should not read or write to.

retentive data

Information associated with data files (timers, counters, inputs, and outputs) in a program that is preserved through power cycles.

RS-232

An EIA standard that specifies electrical, mechanical, and functional characteristics for serial binary communication circuits. A single-ended serial communication interface.

run mode

This is an executing mode during which the controller scans or executes the ladder program, monitors input devices, energizes output devices, and acts on enabled I/O forces.

rung

Ladder logic is comprised of a set of rungs. A rung contains input and output instructions. During Run mode, the inputs on a rung are evaluated to be true or false. If a path of true logic exists, the outputs are made true. If all paths are false, the outputs are made false.

save

To upload (transfer) a program stored in memory from a controller to a personal computer; OR to save a program to a computer hard disk.

scan time

The time required for the controller to execute the instructions in the program. The scan time may vary depending on the instructions and each instruction's status during the scan.

sinking

A term used to describe current flow between an I/O device and controller I/O circuit — typically, a sinking device or circuit provides a path to ground, low, or negative side of power supply.

sourcing

A term used to describe current flow between an I/O device and controller I/O circuit — typically, a sourcing device or circuit provides a path to the source, high, or positive side of power supply.

status

The condition of a circuit or system, represented as logic 0 (OFF) or 1 (ON).

terminal

A point on an I/O module that external I/O devices, such as a push button or pilot light, are wired to.

throughput

The time between when an input turns on and the corresponding output turns on.

true

The status of an instruction that provides a continuous logical path on a ladder rung.

upload

Data is transferred to a programming or storage device from another device.

watchdog timer

A timer that monitors a cyclical process and is cleared at the conclusion of each cycle. If the watchdog runs past its programmed time period, it causes a fault.

workspace

The main storage available for programs and data and allocated for working storage.

write

To copy data to a storage device. For example, the processor WRITES the information from the output data file to the output modules.

Numerics

- 1747-BA battery** 33
 - 1762 expansion I/O dimensions** 39
 - 1762-24AWA wiring diagram** 53
 - 1762-IA8 wiring diagram** 59
 - 1762-IF20F2**
 - input type selection 67
 - output type selection 69
 - terminal block layout 70
 - wiring 69
 - 1762-IF4**
 - input type selection 71
 - terminal block layout 72
 - 1762-IQ16 wiring diagram** 60
 - 1762-IQ32T wiring diagram** 61
 - 1762-IQ8 wiring diagram** 60
 - 1762-IQ80W6 wiring diagram** 67
 - 1762-OA8 wiring diagram** 61
 - 1762-OB16 wiring diagram** 62
 - 1762-OB32T wiring diagram** 63
 - 1762-OB8 wiring diagram** 62
 - 1762-OV32T wiring diagram** 64
 - 1762-OW16 wiring diagram** 65
 - 1762-OW8 wiring diagram** 64
 - 1762-OX6I wiring diagram** 66
 - 5/05 processors**
 - Ethernet communications 383
- ## A
- address** 405
 - Advanced Interface Converter. See AIC+**
 - advanced LCD configuration** 133
 - agency certifications** 23
 - AIC+**
 - applying power to 98
 - attaching to the network 97
 - connecting 92
 - definition 405
 - installing 97
 - recommended user supplied components 96
 - safety consideration 97
 - selecting cable 94
 - analog cable grounding** 59
 - analog channel wiring guidelines** 57
 - analog expansion I/O** 212
 - diagnostics 212
 - module operation vs. channel operation 212
 - power-up diagnostics 212
 - system wiring guidelines 67
 - troubleshooting 212
 - analog inputs**
 - analog channel wiring guidelines 57

application 405

B

- battery** 172
 - processor battery life expectancy 201
 - processor replacement battery 201
- baud rate** 405
- before calling for assistance** 215
- bit** 405
- bit file monitoring** 112
- block diagrams** 405
- Boolean operators** 405
- BOOTP**
 - configuring SLC 5/05 392–395
 - using the Rockwell Utility 393
- branch** 405
- buttons** 107

C

- cable pinout**
 - MicroLogix controller channel 0 to modem cable 82, 92
- cables**
 - planning routes for DH485 connections 244
 - selection guide for the AIC+ 94
- calling for assistance** 215
- CE mark** 23, 24
- changing communication configuration** 77
- changing mode switch position** 129
- collision avoidance** 344
- common mode rejection ratio**
 - specification 197
- common techniques used in this manual** 14
- communication**
 - DeviceNet 99
 - Ethernet 99
- communication connections** 75
- communication options** 20
- communication protocols**
 - ASCII 249
 - DF1 Full-Duplex 237
 - DF1 Half-Duplex 238
 - DH485 241
 - DNP3 249
 - Ethernet 383
 - Modbus 249
 - supported 75
- communication scan** 405
- communications toggle push button**
 - using 76

component descriptions 16
 1762 expansion I/O 17
 communication cables 18
 memory module 16
 real-time clock 16

configuration errors 214

configure processor with DHCP server 395

configuring
 Ethernet network 136
 IP address 138

configuring the Ethernet channel 390

connecting expansion I/O 41

connecting the system
 AIC+ 92, 97
 DeviceNet network 99
 DF1 Full-Duplex protocol 79
 DF1 isolated point-to-point connection 80
 DH485 network 86

connecting to DF1 Half-Duplex network 84

connecting to networks via Ethernet interface 383

connecting to networks via RS-232/RS-485 interface
 237

connections to the Ethernet network 385

control profile 406

ControlFLASH
 error messages 232
 firmware upgrade 222
 missing or corrupt OS state 234
 using 217

controller 406
 grounding 47
 I/O wiring 55
 installation 23
 LED status error conditions 209
 LED status normal operation 209
 minimizing electrical noise 55
 mounting 36
 mounting dimensions 35
 mounting on DIN rail 37
 mounting on panel 38
 preventing excessive heat 29
 status indicators 207

controller modes 129

controller overhead 406

controller spacing 35

counter 406

CPU (Central Processing Unit) 406

cursor display 108

D

data table 406

default communication configuration 76

DeviceNet Communications 99

DeviceNet network

connecting 99

DF1 Full-Duplex protocol

connecting 79, 80

description 237

example system configuration 238

using a modem 81, 240

DF1 Half-Duplex protocol

description 238

DH485 communication protocol

configuration parameters 87, 242

DH485 network

configuration parameters 245

connecting 86

devices that use the network 242

example system configuration 247

installation 89

planning considerations 243

DIN rail 406

disable

Ethernet channel 398

EtherNet/IP Incoming Connections 283

serial channels 250

disconnecting main power 26

Distributed Network Protocol (DNP3) 249

DNP3

analog input object 310

analog output object 314

BCD object 316

binary input object 298

binary output object 300

counter object 305

device attribute object 331

diagnostics 354

double bit binary input object 303

frozen counter object 308

objects 290

slave application layer 284

slave application layer configuration parameters 269

double integer file monitoring 121

download 406

download a user program via DNP3 network 346

DTE (Data Terminal Equipment) 406

duplicate IP address detection 389

E

Electronics Industries Association (EIA) 237

EMC Directive 23, 24

EMI 407

encoder 407
error recovery model 210
errors
 configuration 214
 critical 213
 extended error information field 214
 hardware 214
 module error field 214
 non-critical 213
Ethernet
 advanced functions 396
 messaging 384
 processor performance 384
 using the SLC 5/05 processors 383
Ethernet channel
 disable 398
Ethernet communication 383
Ethernet connections 388
Ethernet network configuration 136
Ethernet protocol setup 145
EtherNet/IP Incoming Connections
 disable 283
European Union Directive compliance 23
 EMC Directive 23
 low voltage directive 24
event generation control 340
executing mode 407
expansion I/O
 1762-IF20F2 input type selection 67
 1762-IF20F2 output type selection 69
expansion I/O mounting 39, 40
 mounting on DIN rail 39
expansion I/O specifications 187
expansion I/O wiring 59
 1762-IA8 wiring diagram 59
 1762-IF20F2 wiring 69
 1762-IF4 terminal block layout 72
 1762-IQ16 wiring diagram 60
 1762-IQ32T wiring diagram 61
 1762-IQ8 wiring diagram 60
 1762-IQ80W6 wiring diagram 67
 1762-OA8 wiring diagram 61
 1762-OB16 wiring diagram 62
 1762-OB32T wiring diagram 63
 1762-OB8 wiring diagram 62
 1762-OV32T wiring diagram 64
 1762-OW16 wiring diagram 65
 1762-OW8 wiring diagram 64
 1762-OX6I wiring diagram 66
 analog wiring guidelines 67
extended error information field 214

F

false 407
FIFO (First-In-First-Out) 407
file 407
file authentication rules 349
full-duplex 80, 407

G

general considerations 24
generating DNP3 events 335
grounding the controller 47

H

half-duplex 85, 407
hard disk 407
hardware errors 214
hardware features 15
heat dissipation
 calculating 403
heat protection 29
high byte 408

I

I/O (Inputs and Outputs) 408
I/O status indicators 109
implementation table 371
initialize user program 353
input device 408
input states on power down 28
inrush current 408
installing
 battery wire connector 34
 ControlFLASH software 217
 memory module 32
 your controller 23
instruction 408
instruction set 408
isolated link coupler
 installing 89
isolation transformers
 power considerations 27

J

jump 408

L

ladder logic 408

LCD

- configuring advanced settings 133
- I/O status indicators 109, 209
- loading communication EEPROM 153
- main menu 105
- menu structure tree 102
- saving communication EEPROM 153
- setup 156
- status indicators 208
- user defined screen 131
- viewing fault code 152
- viewing system information 151

least significant bit (LSB) 408**LED (Light Emitting Diode)** 408**LIFO (Last-In-First-Out)** 409**link layer configuration parameters** 260**lithium battery (1747-BA)**

- disposing 205
- handling 203
- installing 201
- manufacturer 205
- storing 203
- transporting 203

loading communication EEPROM 153**logic** 409**low byte** 409**M****manually configuring channel 1 for controllers on subnets** 397**manuals**

- related 14

master control relay 29

- emergency-stop switches 30
- using ANSI/CSA symbols schematic 32
- using IEC symbols schematic 31

Master Control Relay (MCR) 409**master control relay circuit**

- periodic tests 27

memory module 16

- data file protection 173
- information file 174
- operation 172
- program and data download 174
- program and data upload 174
- program compare 173
- program/data/recipe backup 173
- removal/installation under power 174
- write protection 173

menu structure 102**menu structure tree** 102**minimizing electrical noise** 55**minimizing electrical noise on analog channels** 58**mnemonic** 409**Modbus communication protocol** 249**mode switch** 128**modem** 409**modem cable**

- constructing your own 82

modems

- using with MicroLogix controllers 240

modes 409**module error field** 214**monitoring user defined target files** 111**motor starters (bulletin 509)**

- surge suppressors 46

N**negative logic** 409**network** 409**nominal input current** 409**normally closed** 410**normally open** 410**null modem cable** 83**O****object quality flags** 328**oerformance considerations** 384**offline** 410**offset** 410**off-state leakage current** 410**one-shot** 410**online** 411**Online Editing**

- Terms 176

online editing 175

- edit functions in program online editing 180

- edit functions in runtime online editing 179

- types 179

operating buttons 107**operating voltage** 411**output device** 411**P****performance**

- Ethernet processor 384

planning considerations for a network 243

power considerations

- input states on power down 28
- isolation transformers 27
- loss of power source 28
- other line conditions 28
- overview 27
- power supply inrush 27

power distribution 27**power source**

- loss of 28

power supply inrush

- power considerations 27

preparing for upgrade 217**preventing excessive heat** 29**processor** 411**processor file** 411**program file** 411**program mode** 411**program scan** 411**programming** 19**programming device** 411**protocol** 411**publications**

- related 14

purpose of this manual 13**R****read** 412**real-time clock** 16

- battery operation 172
- operation 171
- removal/installation under power 171
- writing data 171

related documentation 14**related publications** 14**relay** 412**relay logic** 412**remote packet support** 246**replacement battery** 201

- disposing 205
- handling 203
- installing 201
- storing 203
- transporting 203

replacement kits 201**replacement parts** 201**reporting event by polled response** 341**reporting event by unsolicited response** 342**reserved bit** 412**restore** 412**retentive data** 412**RS-232** 412**RS-232 communication interface** 237**RS-485 communication interface** 237**rules for downloading a user program** 350**rules for file authentication** 349**rules for initializing a user program** 352**rules for uploading a user program** 352**rules for uploading communication status files** 352**run mode** 412**rung** 412**S****safety circuits** 26**safety considerations** 25

- disconnecting main power 26
- hazardous location 25
- master control relay circuit
 - periodic tests 27
- periodic tests of master control relay circuit 27
- power distribution 27
- safety circuits 26

save 412**saving communication EEPROM** 153**scan time** 413**serial channels**

- disable 250

sinking 413**sinking and sourcing wiring diagrams** 53**sinking wiring diagram**

- 1762-24BWA 53

sourcing 413**sourcing wiring diagram**

- 1762-24BWA 54, 55
- 1766-L32BWA 54

specifications 181**starting and stopping user programs (mode change) via DNP3 network** 353**status** 413**status indicators** 207**supported communication protocols** 75**surge suppressors**

- for motor starters 46
- recommended 46
- using 45

system configuration

- DF1 Full-Duplex examples 238
- DH485 connection examples 247

system loading

- example calculations 400
- limitations 399
- worksheet 401

system loading and heat dissipation 399**T****target user defined file number** 111**terminal** 413**terminal block layouts**

- 1762-IF20F2 70
- 1762-IF4 72
- controllers 49
- terminal groupings 52

terminal groupings 52**throughput** 413**time synchronization** 345**trim pot information function file** 149**trim pot operation** 148**trim pots** 148

- changing values 149
- configuring in LCD function file 150
- error conditions 150
- location 148
- using 148

troubleshooting 207**true** 413**TUF** 111**U****unsupported connections** 18, 80**upload** 413**user defined LCD screen** 131**using communications toggle functionality** 76**using communications toggle push button** 76**using emergency-stop switches** 30**using memory modules** 171**using real-time clock** 171**using the battery** 33**using trim pots** 148**V****viewing fault code** 152**viewing system information** 151**W****wiring analog channels** 56**wiring diagram**

- 1762-IA8 59
- 1762-IF20F2 differential sensor 70
- 1762-IF20F2 single-ended sensor 71
- 1762-IQ16 60
- 1762-IQ32T 61
- 1762-IQ8 60
- 1762-IQ80W6 67
- 1762-OA8 61
- 1762-OB16 62
- 1762-OB32T 63
- 1762-OB8 62
- 1762-OV32T 64
- 1762-OW16 65
- 1762-OW8 64
- 1762-OX6I 66
- 1766-L32AWA input 53
- 1766-L32AWA output 55
- 1766-L32BWA output 55
- 1766-L32BWA sinking 54
- 1766-L32BWA sourcing 54
- 1766-L32BWB output 55
- 1766-L32BWB sinking 54
- 1766-L32BWB sourcing 55
- terminal block layouts 49, 70, 72

wiring diagrams 48**wiring recommendation** 43**wiring with spade lugs** 44**wiring without spade lugs** 44**wiring your controller** 43**working voltage** 186**workspace** 414**write** 414

Rockwell Automation Support

Rockwell Automation provides technical information on the Web to assist you in using its products.

At <http://www.rockwellautomation.com/support/>, you can find technical manuals, a knowledge base of FAQs, technical and application notes, sample code and links to software service packs, and a MySupport feature that you can customize to make the best use of these tools.

For an additional level of technical phone support for installation, configuration, and troubleshooting, we offer TechConnect support programs. For more information, contact your local distributor or Rockwell Automation representative, or visit <http://www.rockwellautomation.com/support/>.

Installation Assistance

If you experience a problem within the first 24 hours of installation, review the information that is contained in this manual.

You can contact Customer Support for initial help in getting your product up and running.

United States or Canada	1.440.646.3434
Outside United States or Canada	Use the Worldwide Locator at http://www.rockwellautomation.com/support/americas/phone_en.html , or contact your local Rockwell Automation representative.

New Product Satisfaction Return

Rockwell Automation tests all of its products to ensure that they are fully operational when shipped from the manufacturing facility. However, if your product is not functioning and needs to be returned, follow these procedures.

United States	Contact your distributor. You must provide a Customer Support case number (call the phone number above to obtain one) to your distributor to complete the return process.
Outside United States	Please contact your local Rockwell Automation representative for the return procedure.

Documentation Feedback

Your comments will help us serve your documentation needs better. If you have any suggestions on how to improve this document, complete this form, publication [RA-DU002](#), available at <http://www.rockwellautomation.com/literature/>.

Rockwell Automation maintains current product environmental information on its website at <http://www.rockwellautomation.com/rockwellautomation/about-us/sustainability-ethics/product-environmental-compliance.page>.

Rockwell Otomasyon Ticaret A.Ş., Kar Plaza İş Merkezi E Blok Kat:6 34752 İçerenköy, İstanbul, Tel: +90 (216) 5698400

www.rockwellautomation.com

Power, Control and Information Solutions Headquarters

Americas: Rockwell Automation, 1201 South Second Street, Milwaukee, WI 53204-2496 USA, Tel: (1) 414.382.2000, Fax: (1) 414.382.4444

Europe/Middle East/Africa: Rockwell Automation NV, Pegasus Park, De Kleetlaan 12a, 1831 Diegem, Belgium, Tel: (32) 2 663 0600, Fax: (32) 2 663 0640

Asia Pacific: Rockwell Automation, Level 14, Core F, Cyberport 3, 100 Cyberport Road, Hong Kong, Tel: (852) 2887 4788, Fax: (852) 2508 1846

Publication 1766-UM001N-EN-P - June 2019

Supersedes Publication 1766-UM001M-EN-P - July 2018

Copyright © 2019 Rockwell Automation, Inc. All rights reserved.