

DIGITALES THERMOSTAT

DIGITAL THERMOSTAT  
THERMOSTAT NUMÉRIQUE  
THERMOSTATO DIGITALE

DE EN FR IT

BERNSTEIN 



MONTAGEANLEITUNG - IV / 2019

ASSEMBLY INSTRUCTIONS / NOTICE DE MONTAGE / ISTRUZIONI DI MONTAGGIO

**DE** LCD-Bildschirmbeschreibungen**Grundlegende technische Eigenschaften:**

Stromversorgung: AC230V ± 10% / 50Hz

Max Heizelement: 2000W

Isolationsklasse: Klasse II

Wasserschutzklasse: IPX4

Schalter: ON / OF

Temperaturbereich:

Analog mit Taste 0°C ~ 55°C

Temperatureinstellbereich: 7°C ~ 30°C

Zeitmodell: 24 Stunden

Wochenmodell: Nummernanzeige 1 ~ 7

Timer-Modell: Mehrstufige Einstellung, Stunden

Programm-Modus: Komfortmodus, Komfortmodus-1, Komfortmodus-2, Eco-Modus, Frostschutz, Abschaltung

**EN** LCD screen descriptions**Basic Technical Characteristics:**

Power supply: AC230V ± 10% / 50HZ

Max heating element: 2000W

Insulation class: Class II

Water protection class: IPX4

Regulation: ON/OFF

Temperature range:

Analogic with knob 0°C ~ 55°C

Temperature setting range: 7°C ~ 30°C

Time model: 24 hours

Week model: number display 1 ~ 7

Timer model: multi-step setting, 1 hour up

Program mode: comfortable, comfortable-1, comfortable-2, economic model, Thaw model, shutdown mode

**FR** Descriptions d'écran LCD**Caractéristiques techniques de base:**

Alimentation: AC230V ± 10% / 50HZ

Élément de chauffage Max: 2000W

Classe d'isolation: Classe II

Classe de protection de l'eau: IPX4

Réglementation: ON / OF

Plage de température:

Analogique avec le bouton 0°C ~ 55°C

Plage de réglage de la température: 7°C ~ 30°C

Modèle de temps: 24 heures

Modèle de la semaine: affichage du nombre 1 ~ 7

Modèle de minuterie:

réglage en plusieurs étapes, 1 heure

Mode programme: Mode Confort, Mode Confort-1,

Mode Confort-2, mode Eco, protection contre le gel, arrêt

**IT** Descrizioni dello schermo LCD**Caratteristiche tecniche di base:**

Alimentazione: AC230V ± 10% / 50HZ

Elemento riscaldante massimo: 2000W

Classe di isolamento: Classe II

Classe di protezione delle acque: IPX4

Regolamento: ON / OF

Intervallo di temperatura:

Analogico con manopola 0°C ~ 55°C

Campo di regolazione della temperatura: 7°C ~ 30°C

Modello temporale: 24 ore

Modello settimanale: display numerico 1 ~ 7

Modello timer:

impostazione multi-step, 1 ora in su

Modalità Programma: Comfort, Comfort-1, Comfort-2,

modalità Eco, protezione antigelo, spegnimento

Einschalter, power button, bouton d'alimentation, pulsante di accensione

Plustaste, plus button, bouton plus, pulsante più

Minustaste, minus button, bouton moins, pulsante meno

Funktionstaste, function key, touche de fonction, tasto funzione

Hauptschalter, Main switch, interrupteur principal, interruttore principale

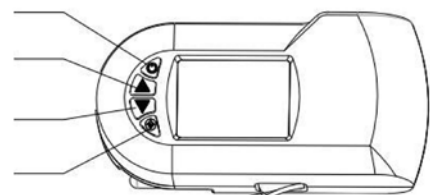

## Bildschirmanzeige:

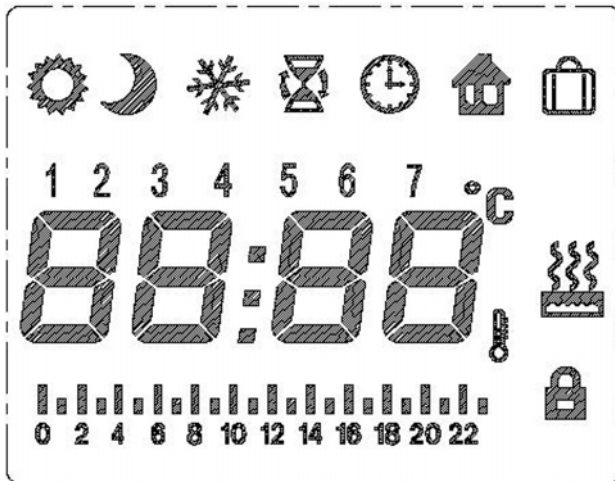

## Icon Display Anweisungen:

Komfortmodus: Um die Tagestemperatur separat einzustellen,  Temperatureinstellbereich 7°C ~ 30°C.

Eco Modus: Um die Nachttemperatur separat einzustellen,  Temperatureinstellbereich 7°C ~ 30°C.  
Die maximale Temperatur darf die Tagestemperatur im Komfortmodus nicht übersteigen.

Frostschutz: Die Temperatur ist auf 7°C festgelegt,  die Temperatur kann nicht geändert werden.

BOOST-Modell: schnelle Aufheizphase, die Zeitspanne kann bis zu 2 Stunden betragen. 

Timer-Modell: Timer-Funktion. 

Programmeinstellungen: 6 Modelle   
1) Komfortmodus, 2) Komfortmodus-1, 3) Komfortmodus-2,  
4) ökonomisches Modell, 5) Frostschutz, 6) Abschaltmodus

Urlaubsmodus: Sie können die Tage und die Temperatur für ihre Abwesenheit einstellen. 

Kabellose Verbindung: Eine kabellose Verbindung ist bei diesem Modell nicht möglich. 

Zeit- und Temperaturanzeige 

Heizfunktion: Heizzustand wird angezeigt 

Kindersicherung: In diesem Status kann keine Operation ausgeführt werden. (Außer zum Ein- und Ausschalten) 

Zeitachse: Einstellzeit, Einstellbereich von 0 ~ 23 Uhr 

Panel display picture:

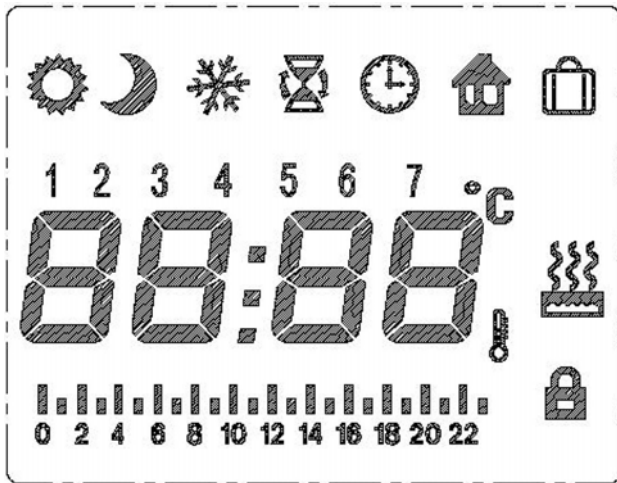

Icon Display instructions:

Comfortable model: To set the daytime temperature separately,  temperature setting range 7°C ~ 30°C.

Economic model: To set the night temperature separately,  temperature setting range 7°C ~ 30°C.  
The maximum temperature can not exceed the comfortable temperature in comfort mode.

Thaw model: The temperature is set to 7°C,  the temperature can not be changed.

BOOST model: continuously heating up, the time span can be up to 2 hours. 

Timer model: Timer function. 

Wire control model: 6 models   
1) comfortable model, 2) comfortable model-1, 3) comfortable model-2,  
4) Economic model, 5) Thaw model, 6) Shutdown mode

Travel model: You can set the days and the temperature for your absence. 

Wireless connection: A wireless connection is not possible with this model. 

Time and temperature display 

Heating function: when in heating status is displayed 

Children lock function: No operation can be performed in this state. (Except for power off and on) 



Timeline: Setting time, setting range from 0 ~ 23 o'clock 

Image d'affichage de panneau:

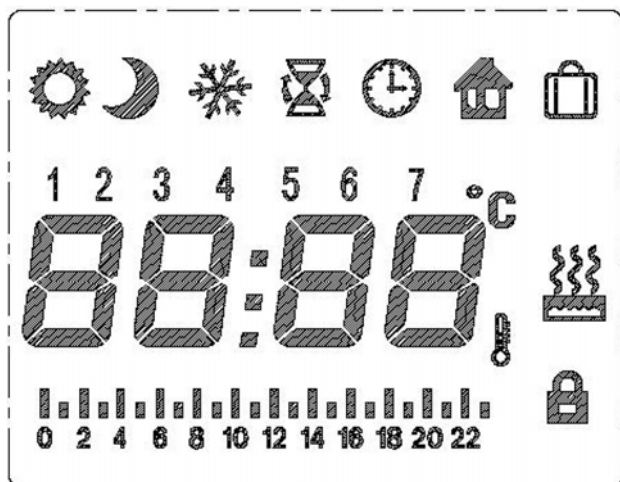

Icônes Afficher les instructions:

Modèle confortable: Pour régler la température diurne séparément,  plage de réglage de température 7°C ~ 30°C.

Mode Eco: Pour régler la température nocturne séparément,  plage de réglage de la température 7°C ~ 30°C.  
La température maximale ne peut pas dépasser la température confortable en mode confort.

Modèle de dégel: La température est réglée à 7°C,  la température ne peut pas être changée.

Modèle BOOST: chauffant continuellement, la durée peut aller jusqu'à 2 heures. 

Modèle de minuterie: Fonction minuterie. 

Modèle de contrôle de fil: 6 modèles 

1) modèle confortable, 2) confortable modèle-1, 3) confortable modèle-2,  
4) Modèle économique, 5) Modèle de dégel, 6) Mode d'arrêt

Modèle de voyage: Vous pouvez définir les jours et la température pour votre absence. 

Connexion sans fil: Une connexion sans fil n'est pas possible avec ce modèle. 

Affichage du temps et de la température. 

Fonction de chauffage: quand en état de chauffage est affiché. 

Verrouillage parental: Aucune opération ne peut être effectuée dans cet état.  (Sauf pour allumer et éteindre)



Chronologie: Réglage de l'heure, plage de réglage de 0 ~ 23 heures. 

Immagine del display del pannello:

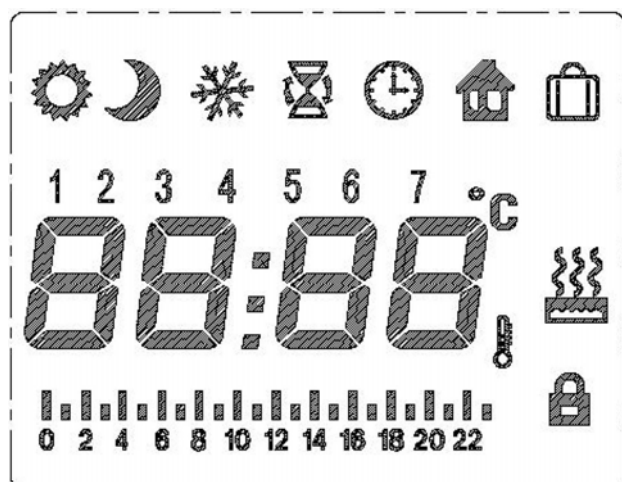

Istruzioni di visualizzazione delle icone:

Modalità comfort: per impostare separatamente la temperatura diurna,  temperatura 7°C ~ 30°C.

Modalità Eco: per impostare separatamente la temperatura notturna,  temperatura 7°C ~ 30°C.  
La temperatura massima non deve superare la temperatura diurna in modalità comfort.

Protezione antigelo: la temperatura è impostata su 7°C,  la temperatura non può essere modificata.

Modello BOOST: riscaldamento rapido, l'intervallo di tempo può essere fino a 2 ore. 

Modello timer: funzione timer. 

Impostazioni del programma: 6 modelli 

1) modalità comfort, 2) modalità comfort-1, 3) modalità comfort-2,  
4) Modello economico, 5) Antigelo, 6) Modalità spegnimento

Modalità vacanze: puoi impostare i giorni e la temperatura per la tua assenza. 

Connessione wireless: una connessione wireless non è possibile con questo modello. 

Visualizzazione di tempo e temperatura. 

Funzione di riscaldamento: viene visualizzato lo stato di riscaldamento. 

Funzione di blocco bambini: nessuna operazione può essere eseguita in questo stato. 

Timeline: tempo di impostazione, intervallo di impostazione da 0 ~ 23 in punto 



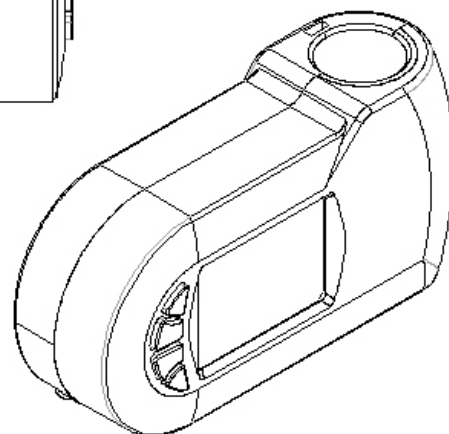
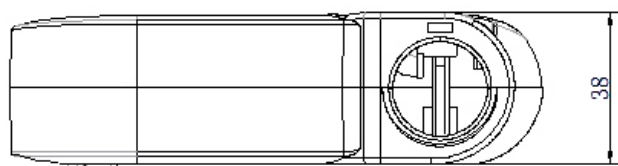
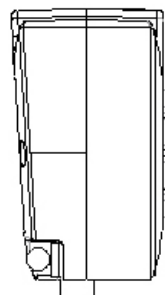
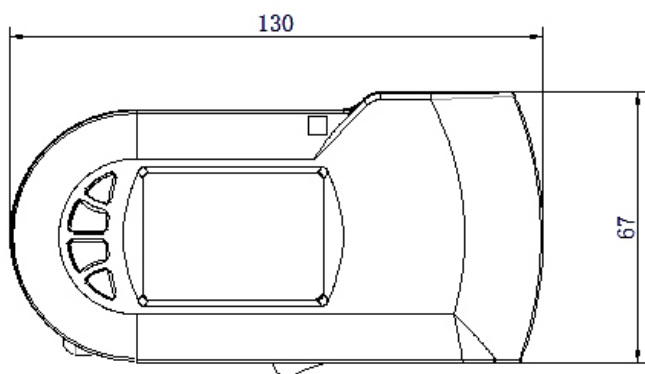

## DE ERKLÄRUNG

Die Bedienungsanleitung dient nur als Referenz. Diese Anleitung kann abweichende Angaben enthalten. Die beschriebenen Produkte können jederzeit aktualisiert werden. Die Zeichnungen in dieser Anleitung dienen nur zur Darstellung und haben keinen Anspruch auf Aktualität.

## EN STATEMENT

This instructions should only be considered as a standard manual. Modifications applied to updated version of the product might not be mentioned inside this document. In this case, please just use the manual as a reference. The company reserves modification rights.

## FR EXPLICATIONS

Les renseignements figurant dans cette notice de montage ne sont communiqués qu'à titre d'information et peuvent être mis à jour sans préavis. Toutes les figures et dessins présents dans ces instructions sont uniquement à titre d'illustration et n'ont aucune valeur d'actualité.

## IT DICHIARAZIONE

Il seguente manuale è solo una guida standard. Nel caso in cui dovessero essere presenti errori, dovuti a eventuali modifiche postume del prodotto, si prega di considerare il manuale unicamente come riferimento per il montaggio. L'azienda si riserva il diritto di modifica.