

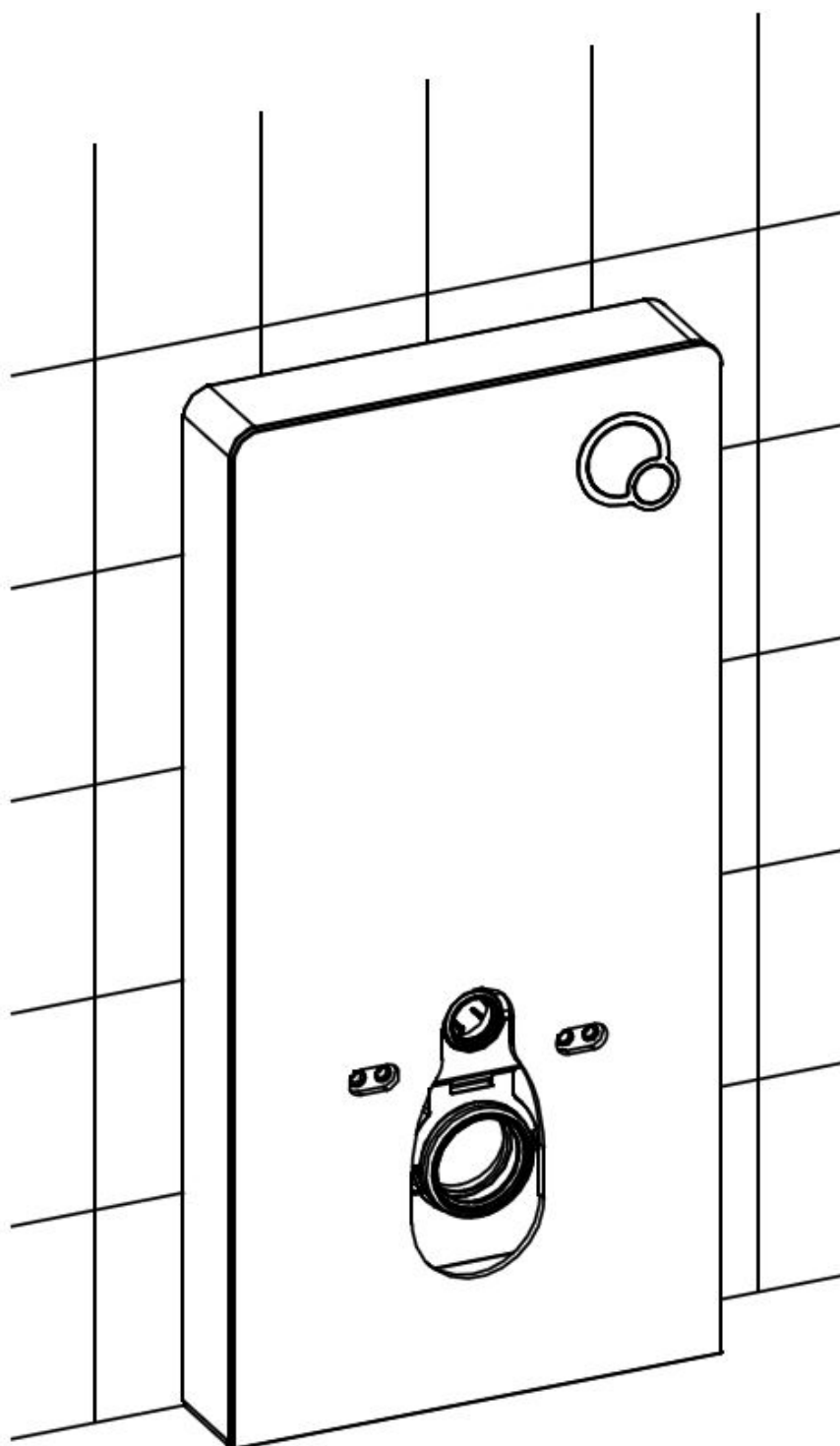























IN-WALL SYSTEM 805  
for wall-wc with flushplate

**BERNSTEIN**  
Living with Style



## CONTENT OF DELIVERY:

Item	Description	Indication	Quantity	Item	Description	Indication	Quantity
	Rubber seal	ø 110	1		Rawl plug	SX10 ø 6-8	2
	Straight flush pipe		1		Screw	ST6,8 x 67	2
	Waste seal		1		Washer	ø 22 x 2,0	2
	Eccentric pipe		1		M12 Bolt		2
	Rubber seal		1		Screw cover		2
	Full flush air hose	transparent	1		M12 Nut		2
	Half flush air hose	blue	1		big Washer	ø 32,5 x 2,5	2
	Absorbing panel		1		Rubber bolt		2
	Flush pipe		1		Screw cover		2
	Rubber seal for the flush pipe	ø 60	1		Stainless steel bolt		2
	Rawl plug	8 x 40	2		Washer	ø 11 x 1,2	2
	Screw	ST4,8 x 45	2				

ITEMS INCLUDED IN DELIVERY:

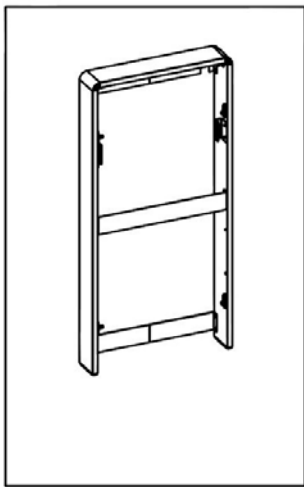

Aluminium frame

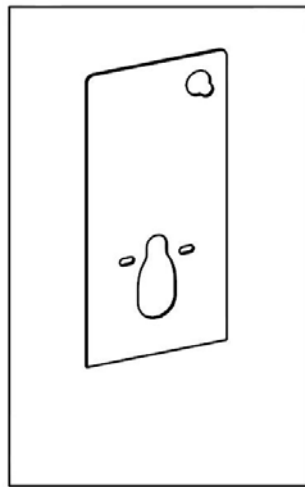

Glass panel

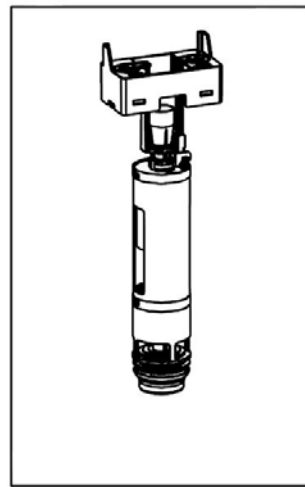

Flush valve

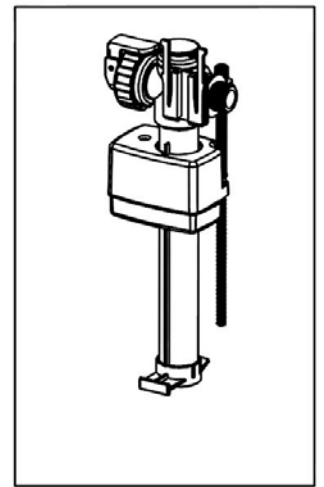

Inlet valve

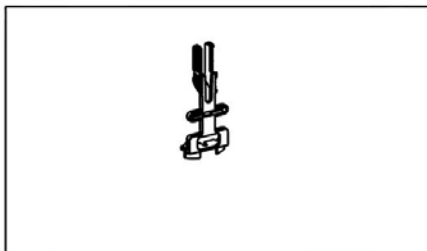

Lever

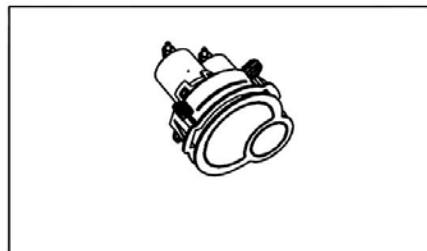

Flush plate

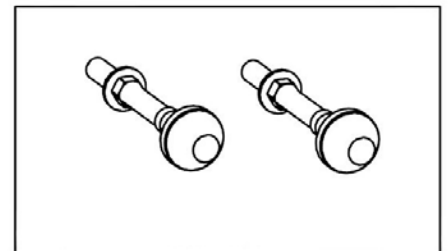

Screw set

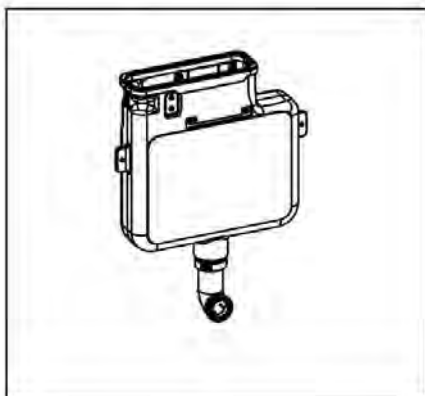

Water cistern

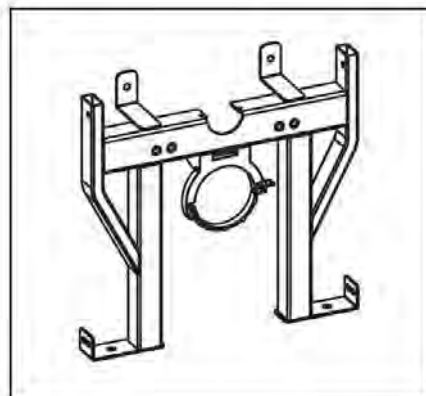

Lower half frame



Drainage pipe

**TECHNICAL SPECIFICATIONS:**

Product type: Wall-hung toilet installation system

Model: 20981 (black) and 20982 (white)

Required room temperature: 3 – 40° C

Water supply pressure: 0,07 – 0,75 MPa

Water temperature: 4 – 35° C

Protection class: IPX4

Dimension: 1003,5 x 483 x 108 mm

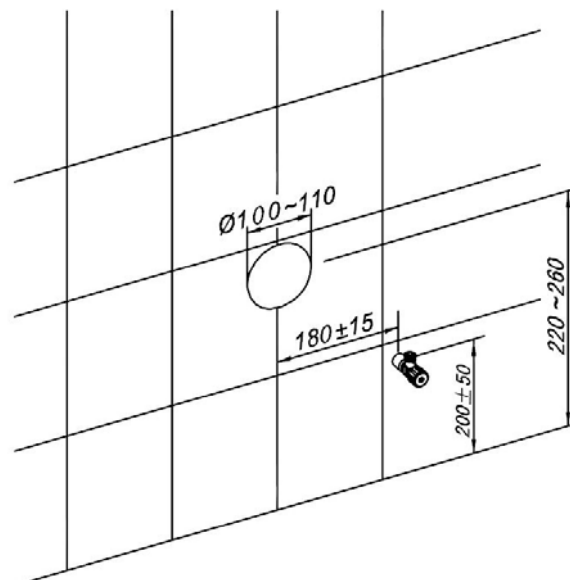
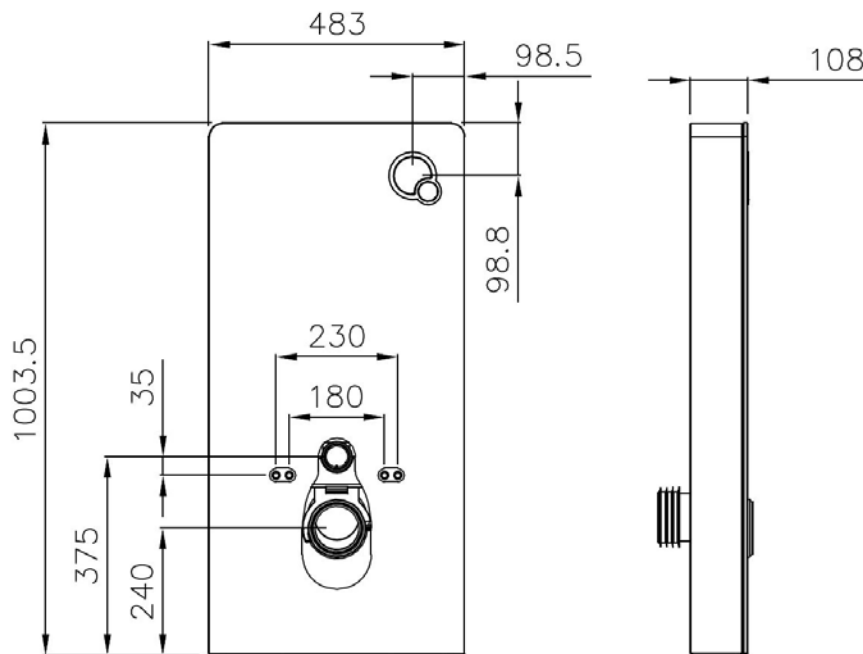
**TECHNICAL DRAWINGS - Water inlet and waste system:**

**INSTALLATION OF THE SANITARY MODULE:**

**1**

Insert the drainage pipe into the pre-drilled drainage hole on the wall.

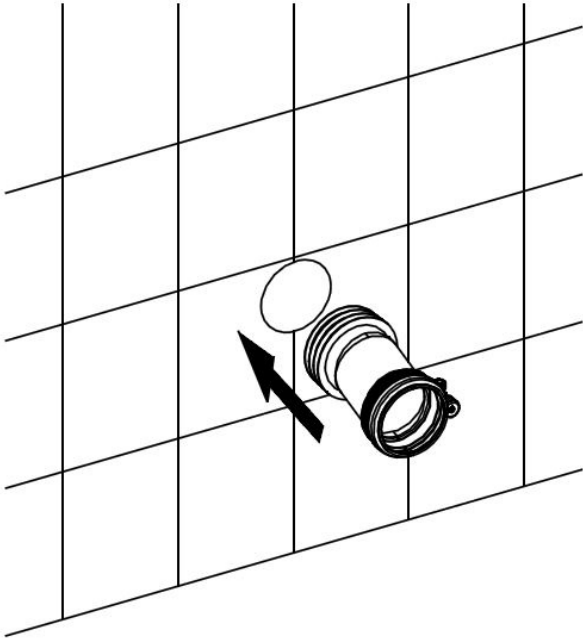

**2a**

Remove the upper cover (1) and the support and the support tube (2).

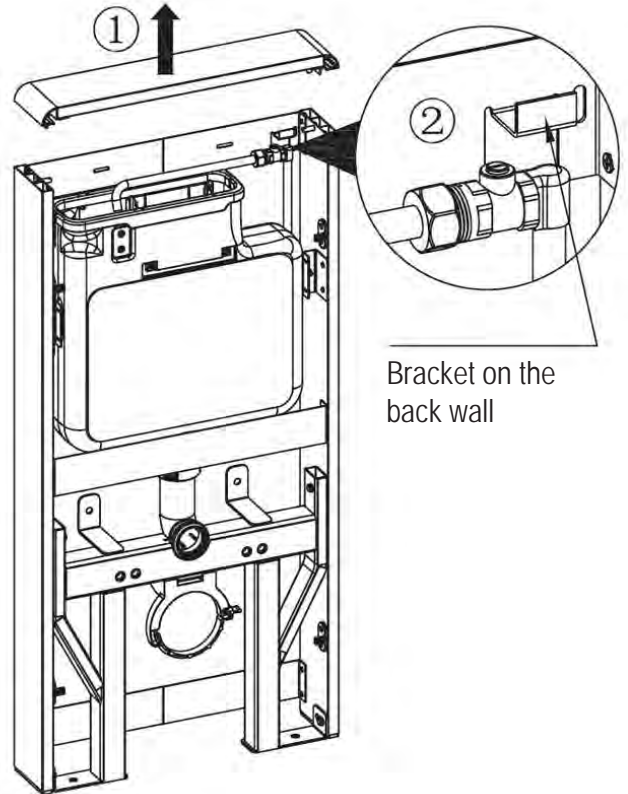

**2b**

Place the sanitary module on the wall and fasten the drainage pipe (1) with the clamp (2).

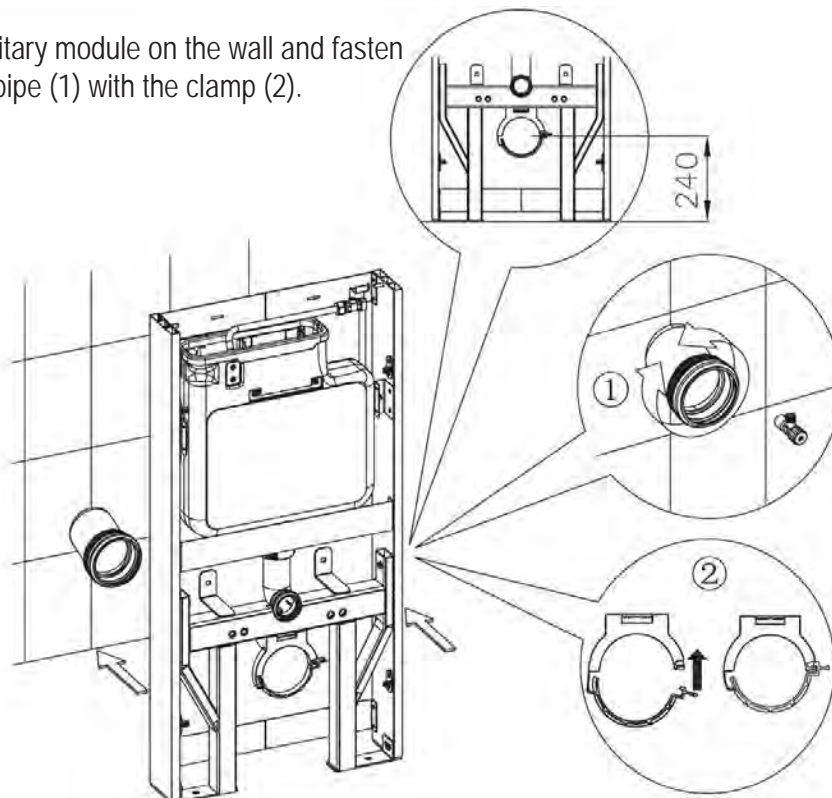

3

Using the given openings - four on the wall, two on the floor - mark the drill holes with a pin (3).

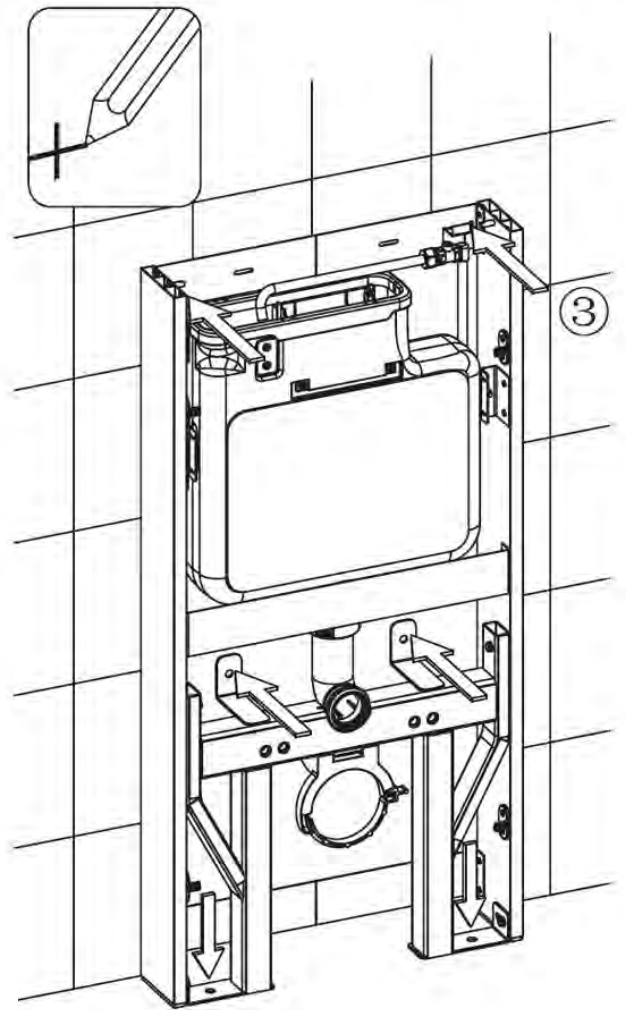

4

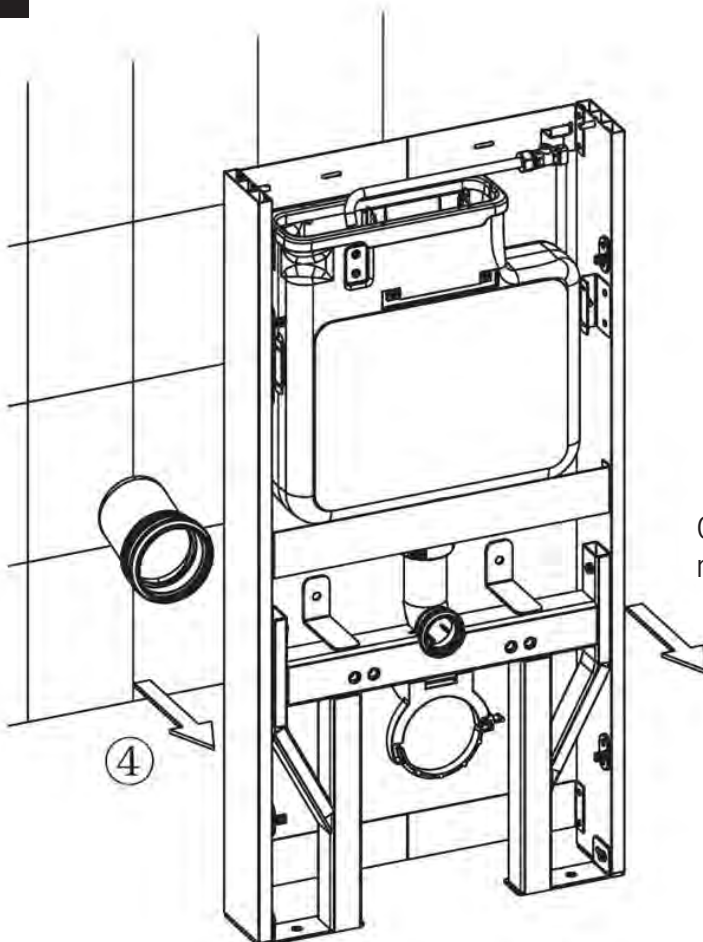

Open the clamp and remove the sanitary module from the wall (4).

5

Drill the holes using the markers.

The depth of the drill holes must be greater than the length of the dowels (see the diameter in the drawing (5)).

Insert the rawl plugs into the corresponding holes (6).

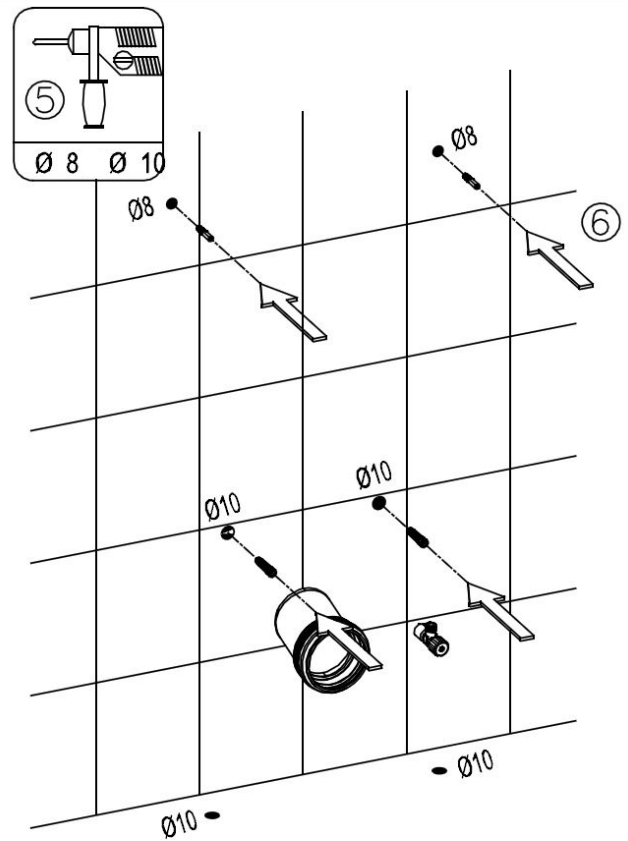

6

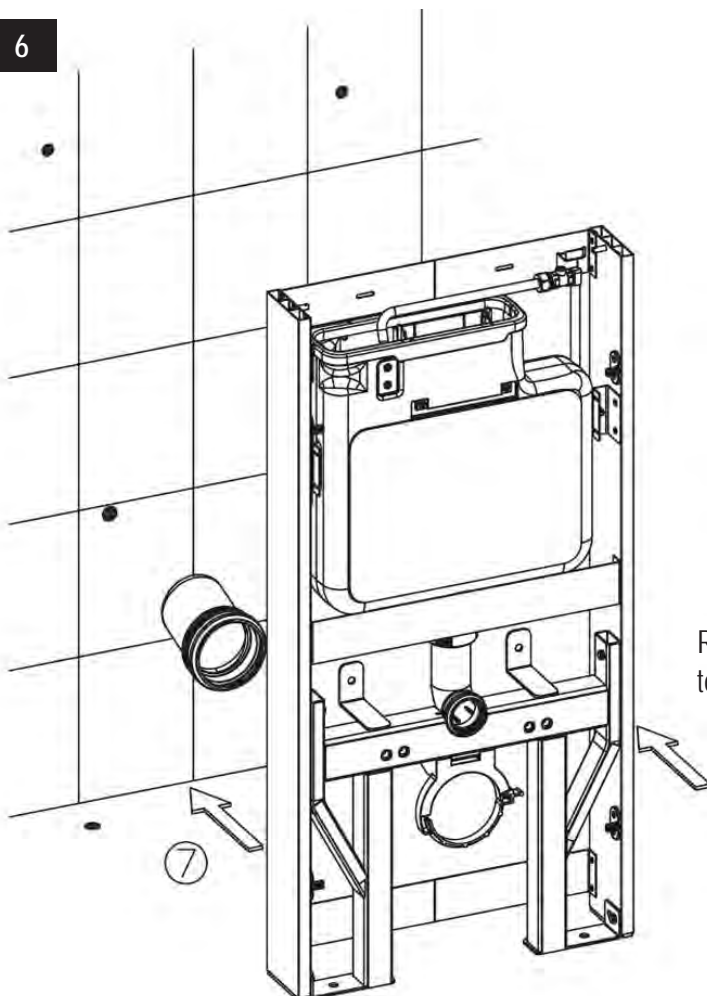

Return the sanitary module to the correct wall position (7).



7

Now fix the unit to the wall tightening the screws in the corresponding rawl plugs (8) and use the bolts to secure the feet on the floor.

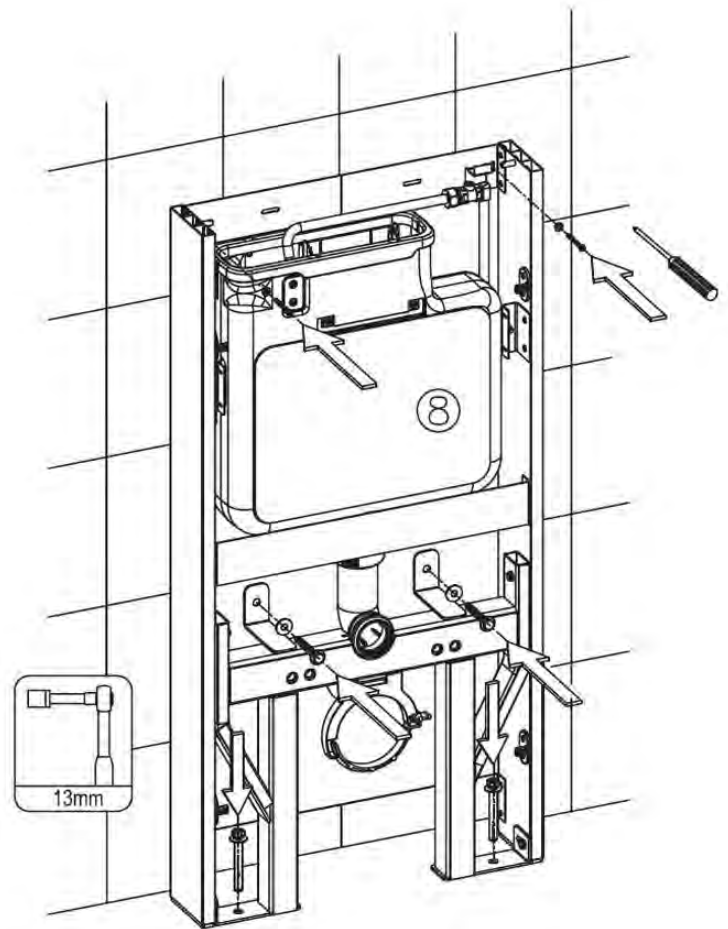

8

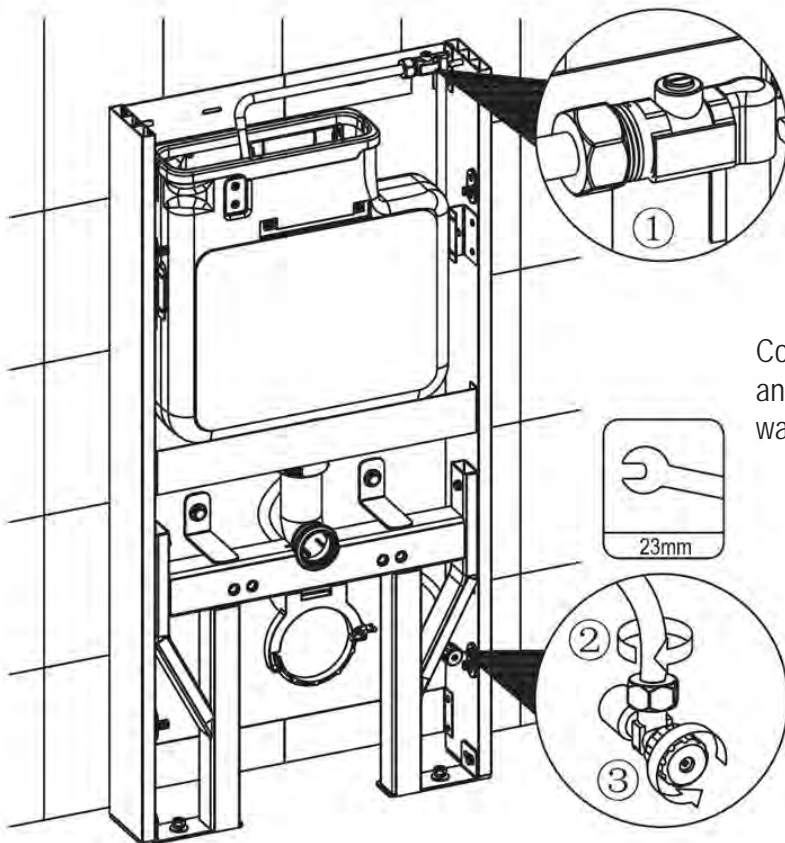

Connect the tube with the support (1) and the corresponding valve on the wall (2 + 3).



9

Open the shut-off valve on the inlet water pipe (4) to check the function.

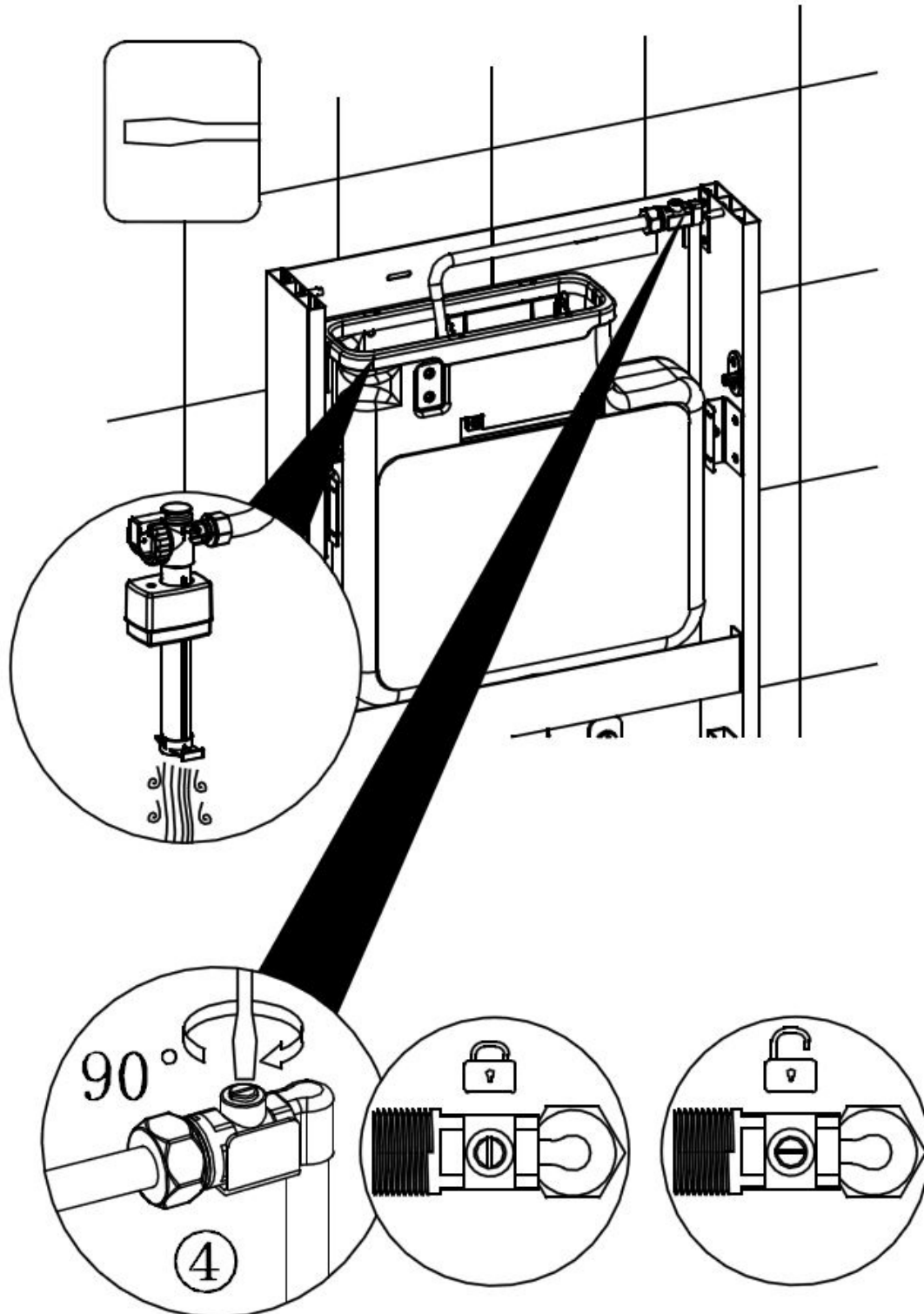

10

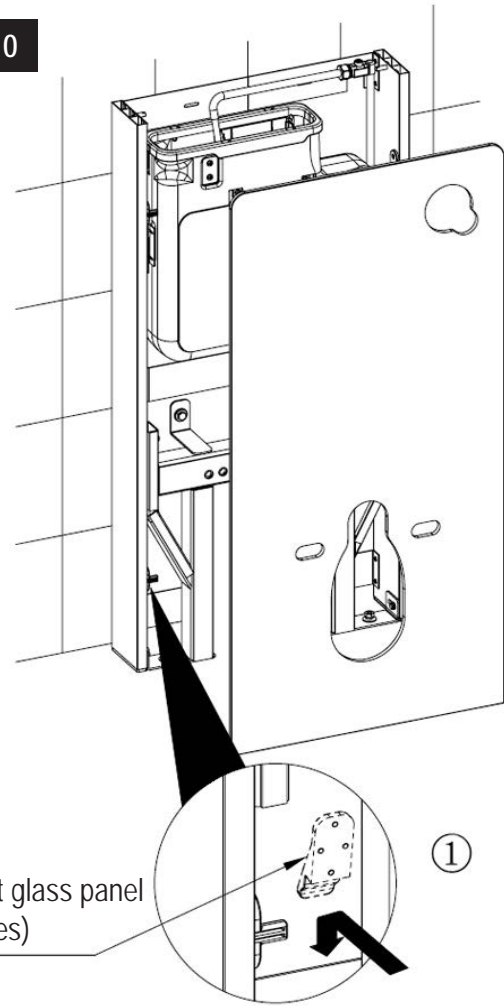

11

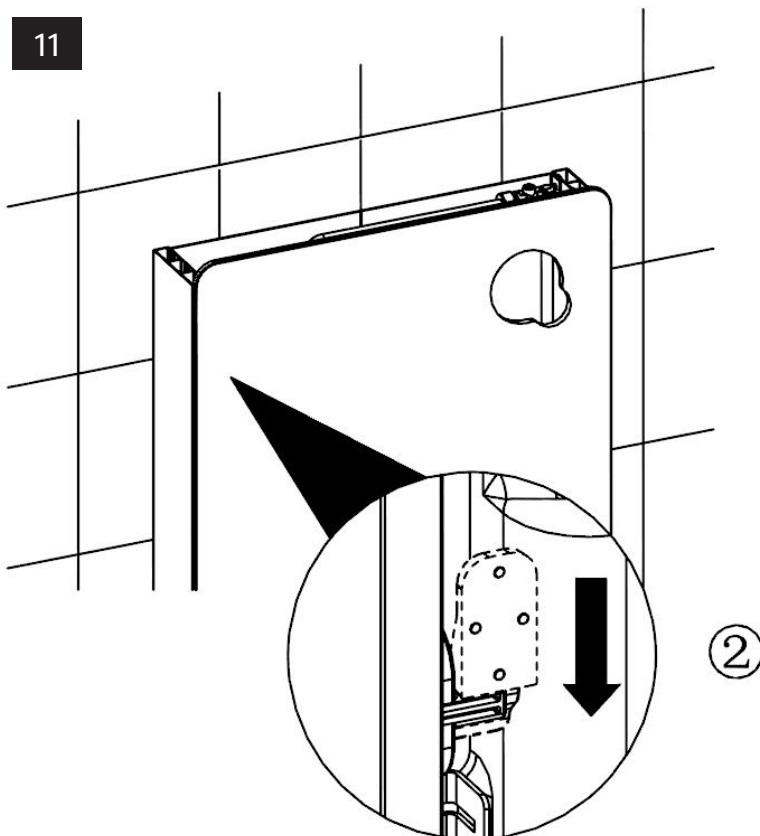

Attach the glass panel to the aluminum frame of the sanitary module (1).

Push it down (2) so the glass panel mounts snap into the frame mounts.

12

Mount the retaining frame (1) from the inside and the pusher plate (2) from the front into the glass panel.

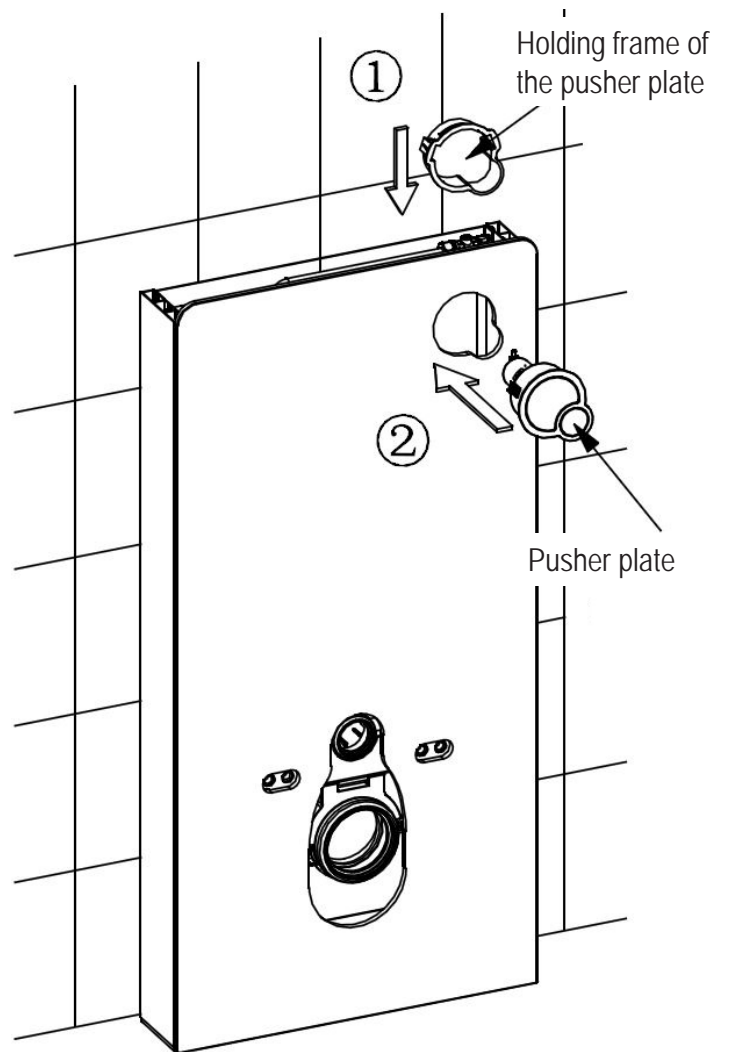

13

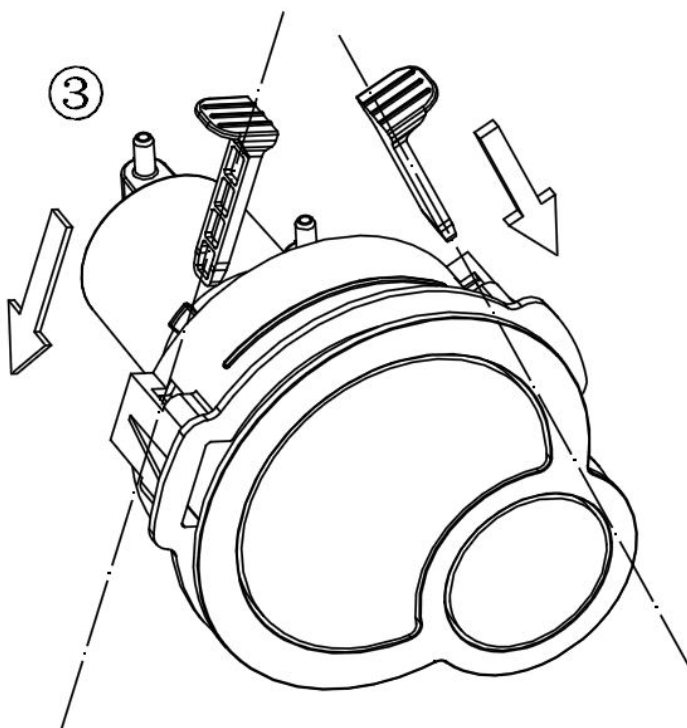

Now push the locks into the holding frame (3) to fix the pusher plate.

14

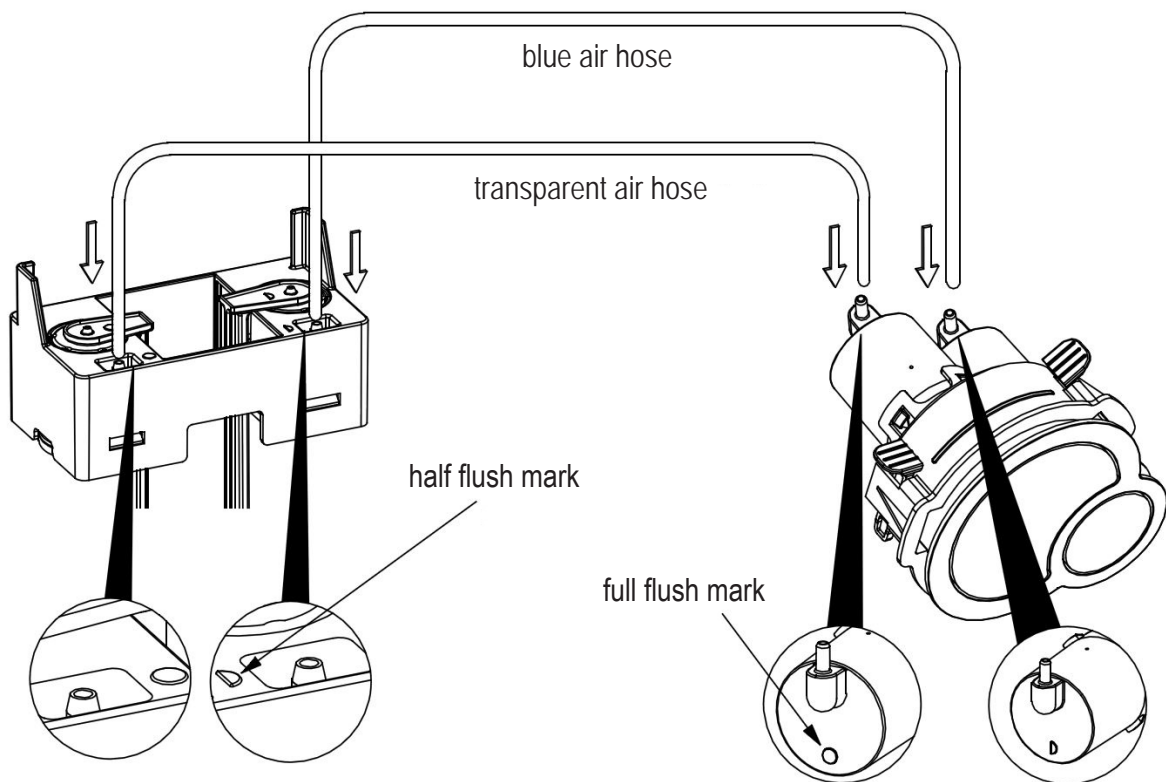

Fix the air hoses as indicated in the above drawing.

15

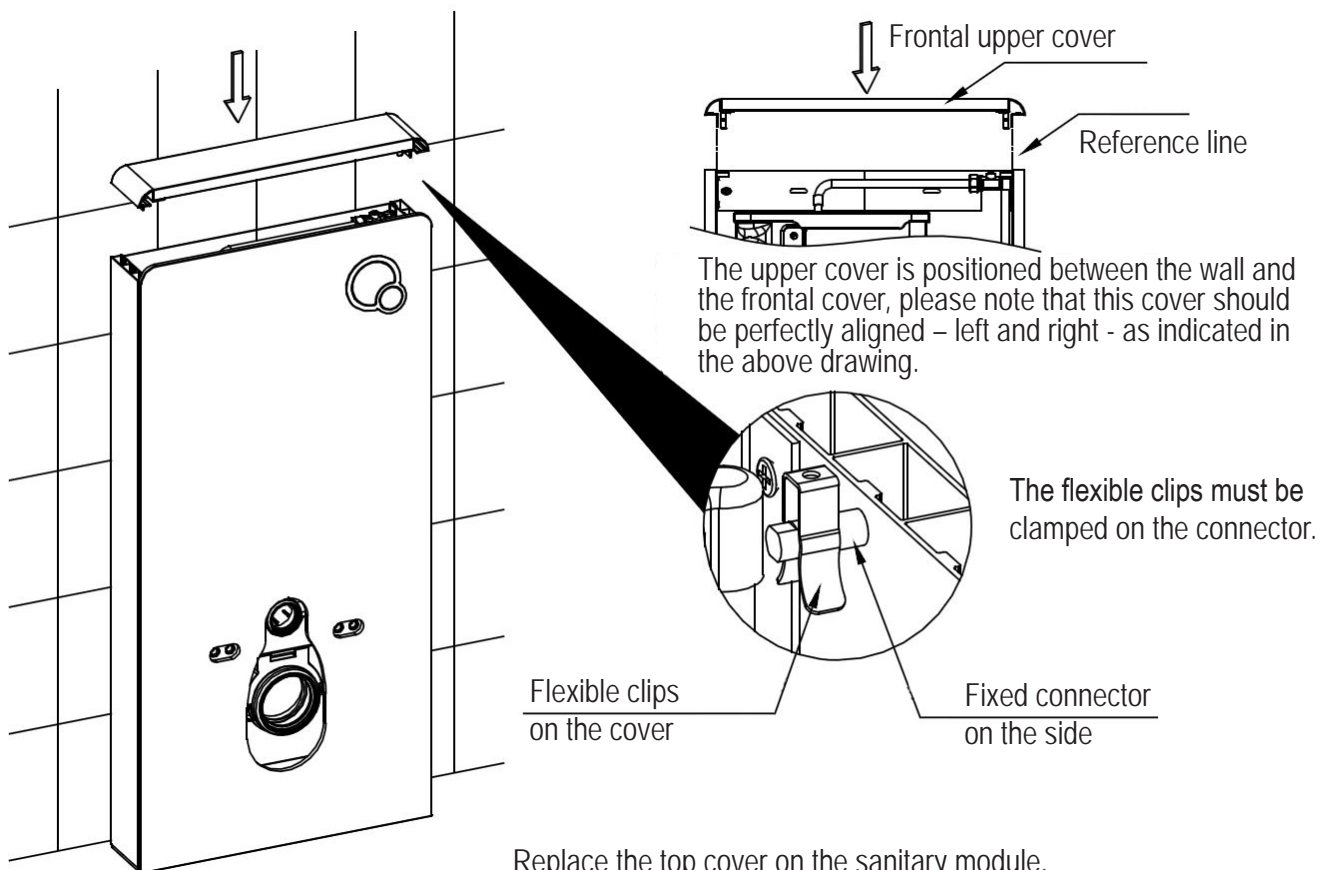

Please follow the following steps (16-18) after installing your wall-hung toilet

16

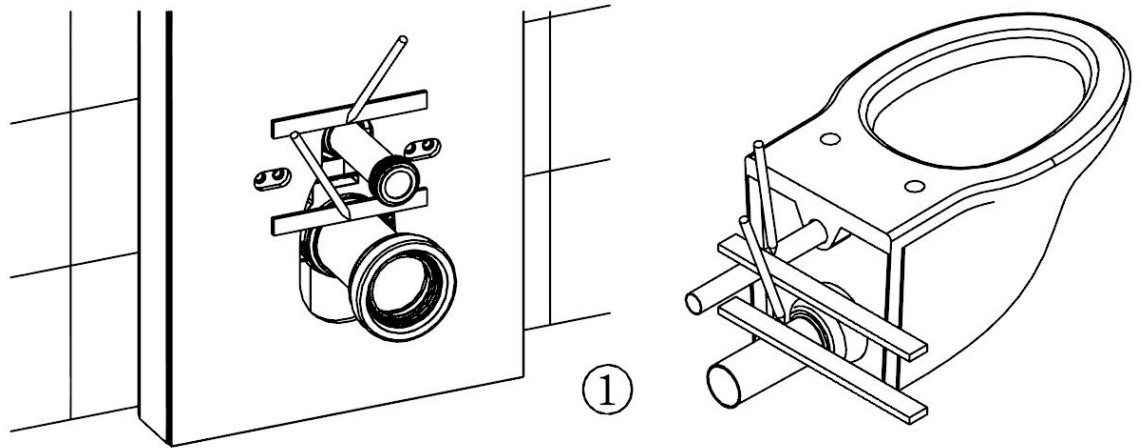
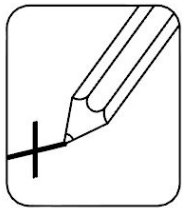
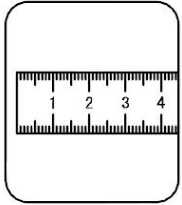

Draw a mark on the straight flush pipe and on the waste pipe (1).

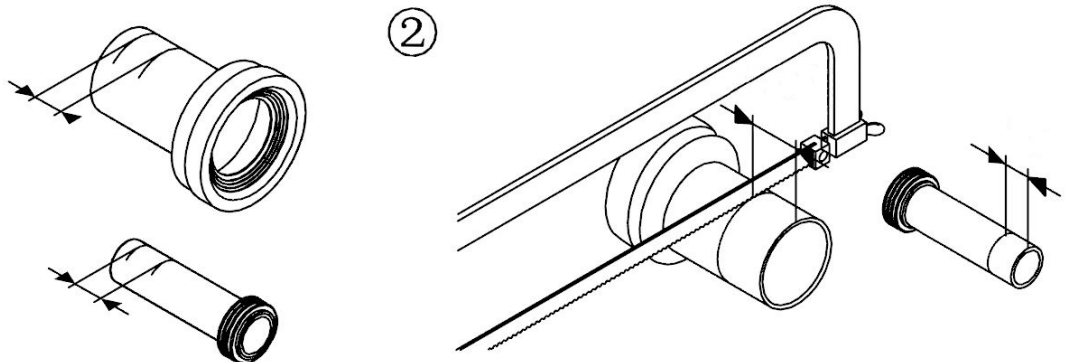
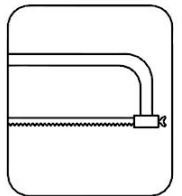

Cut the flush pipe and the waste pipe (2).

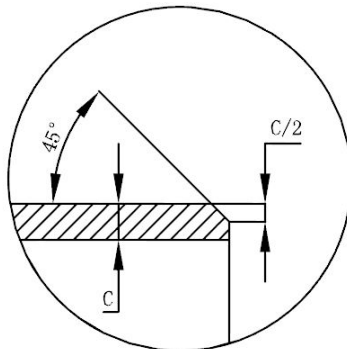
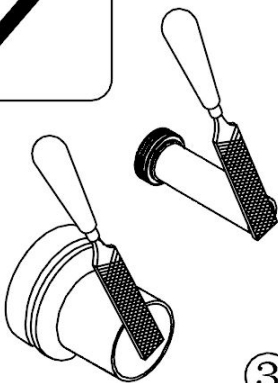

File the edge of the pipes (3).

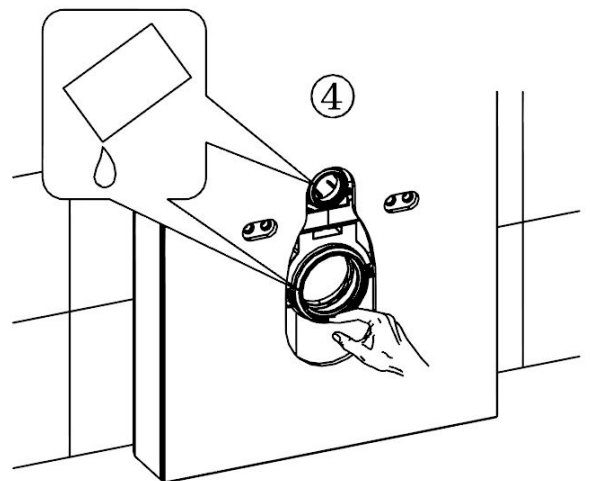

Add silicon oil (4).

17

Fix the bolts on the unit (1)  
and the absorbing panel (2).

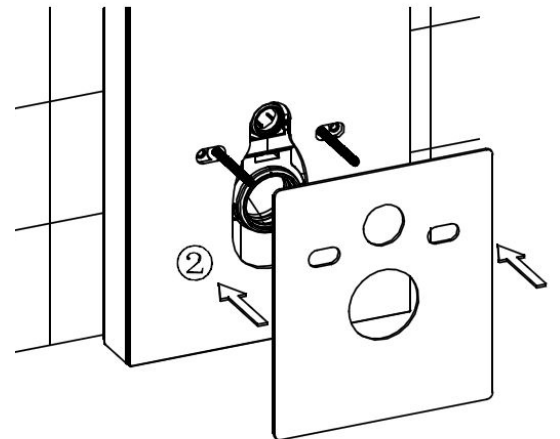
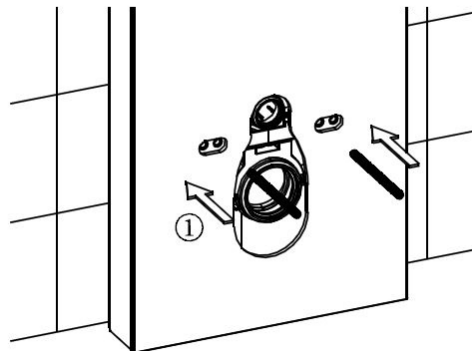
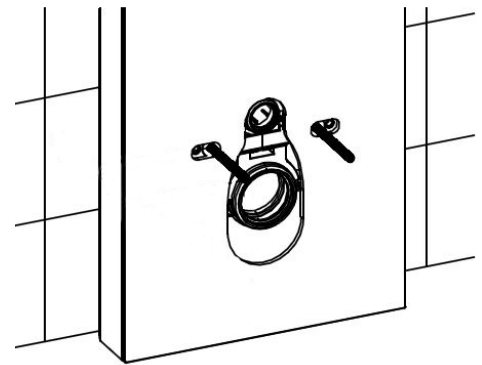
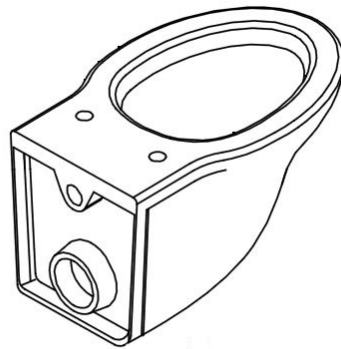

18

Fix the waste pipe  
to the unit (3).

Fix the flush pipe  
to the wall-hung toilet (4).

Install the toilet  
to the sanitary module (5).

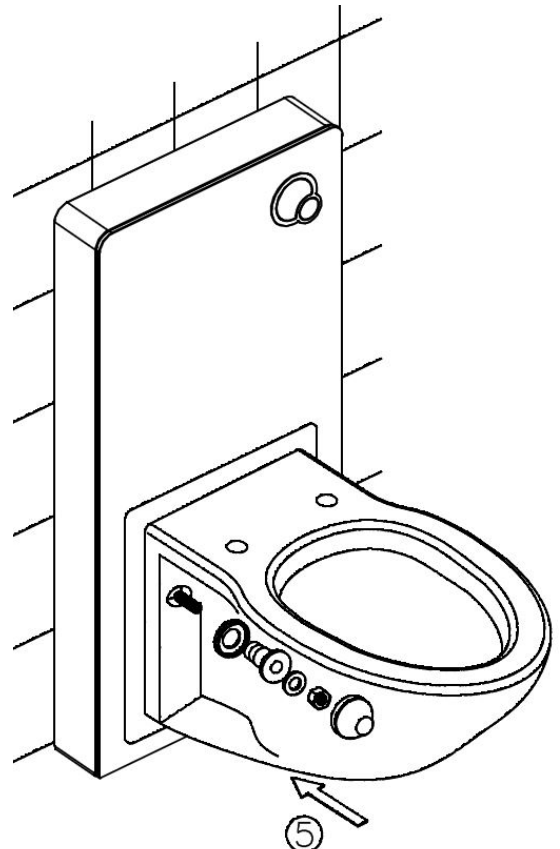
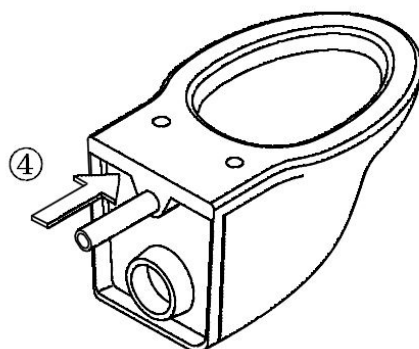
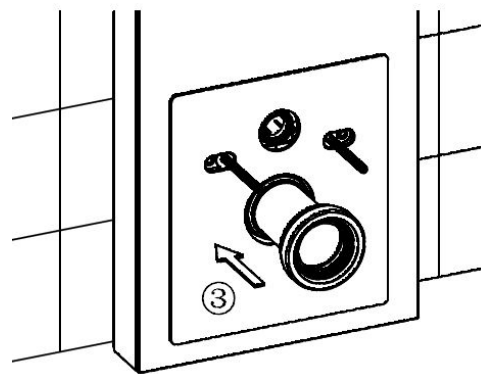



19

Cut off the protruding surfaces (6) of the absorber plate.

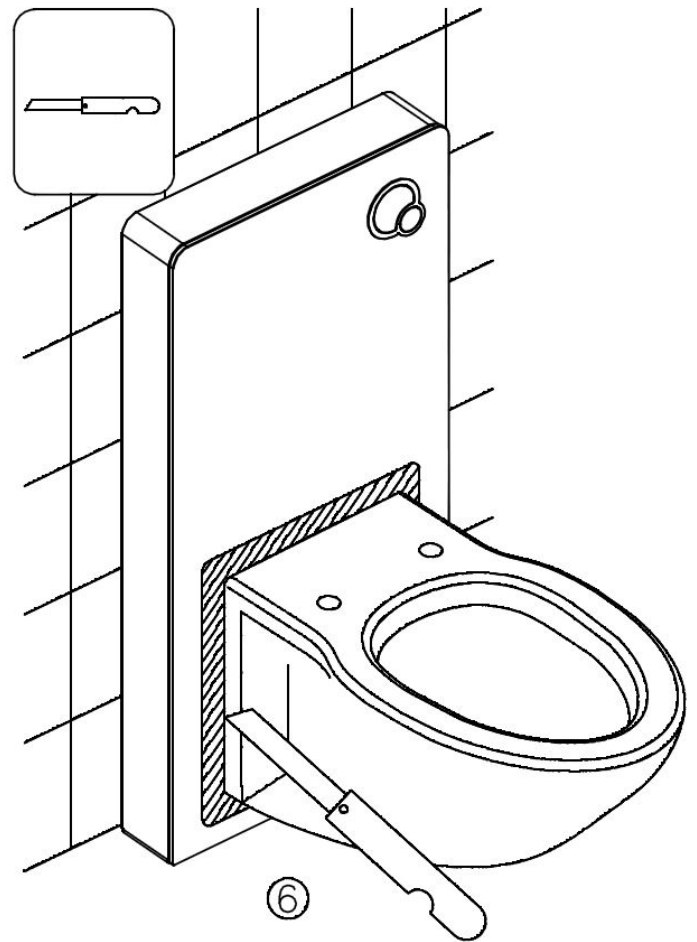

20

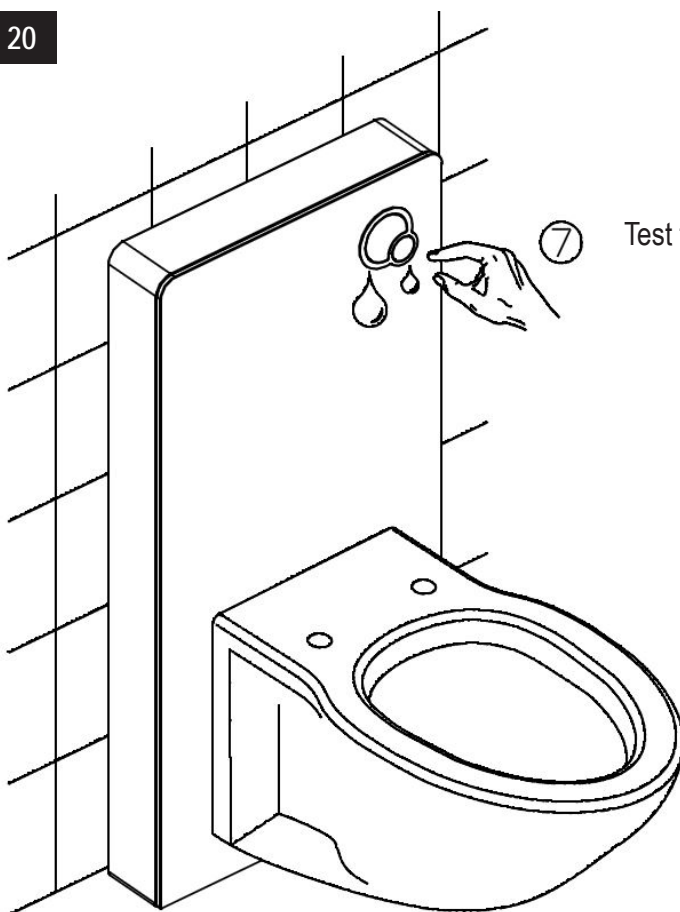

Test the half and full flush functions (7).

**MAINTENANCE:****1.1 How to remove the inlet valve**

Lift the upper cover (1).

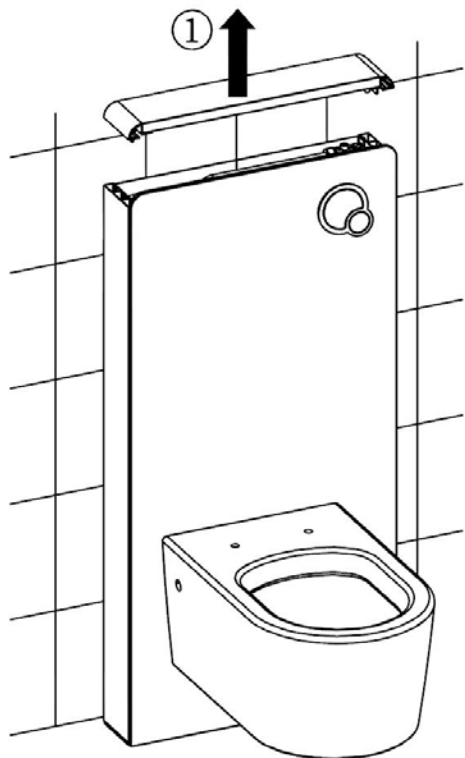

Turn off the stop valve (2) on the flexible hose.

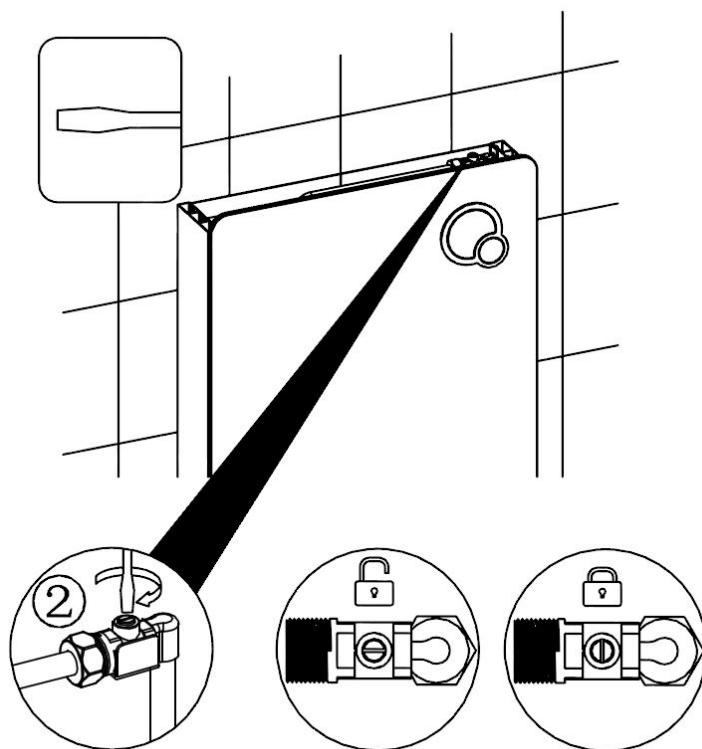

Disconnect the hose and the valve (3).

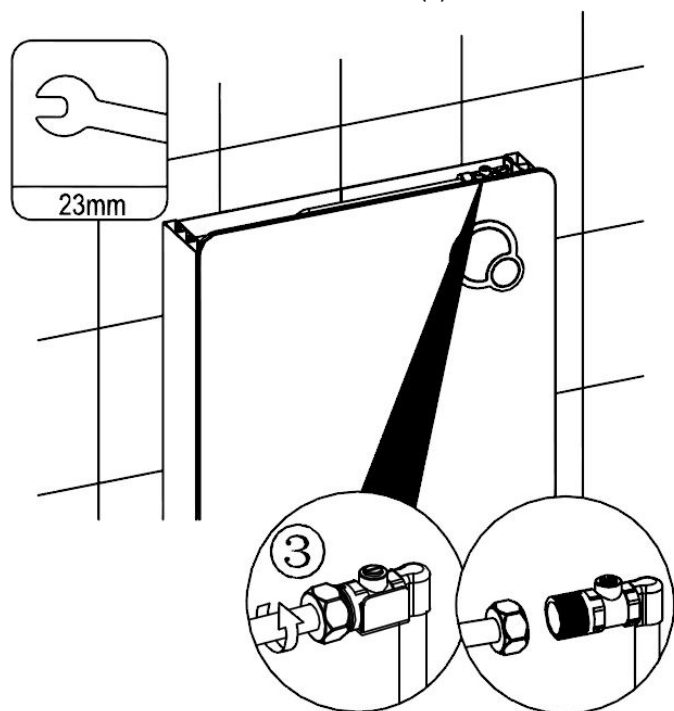

Remove the inlet valve pulling it upwards (4).

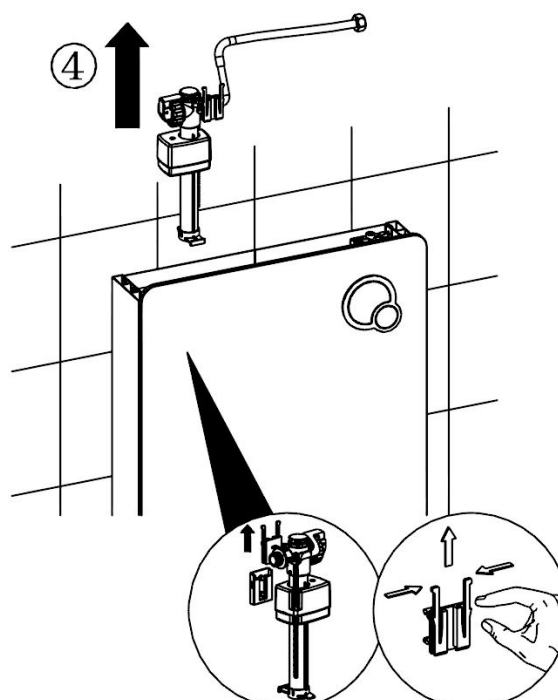

## 1.2 Adjustment and cleaning of the inlet valve

Lift the float (1) upwards to increase the waterflow or downwards to reduce it.

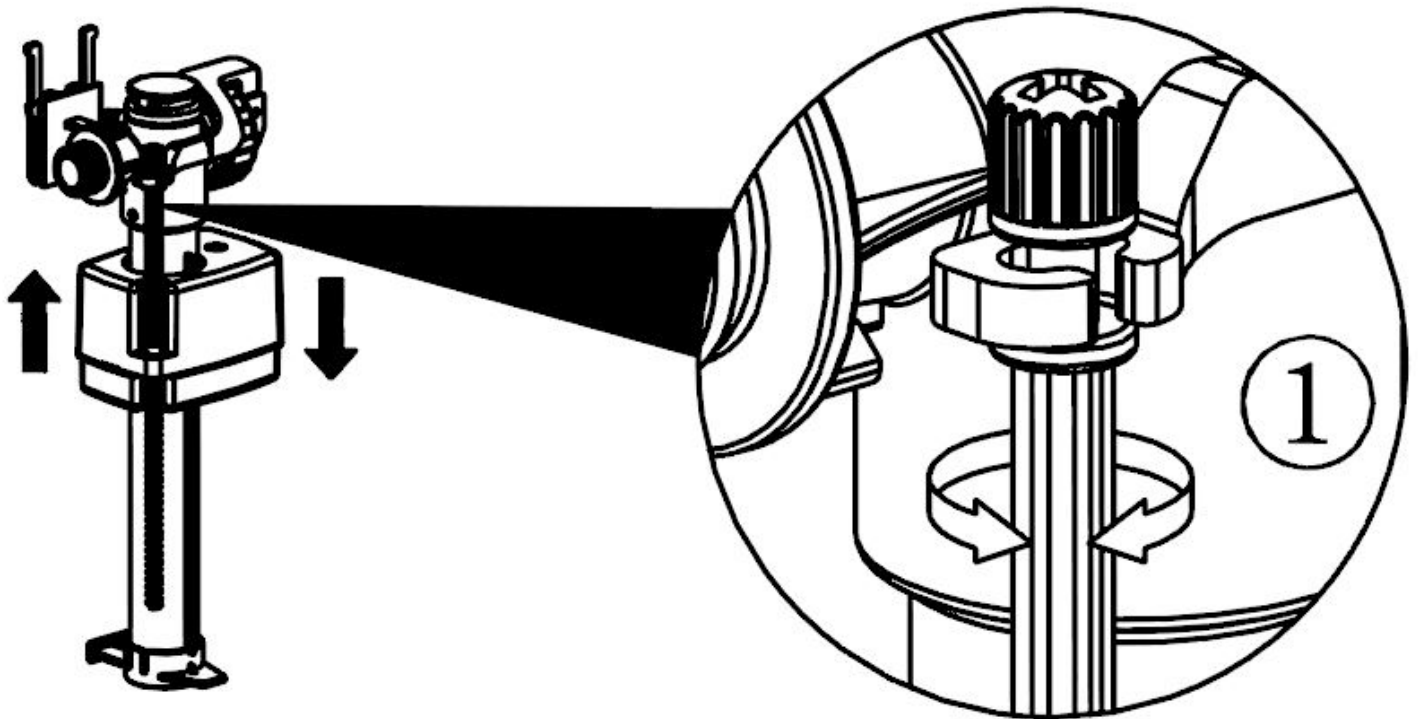

Remove the stop valve (2+3) and clean it et nettoyez-la (4).

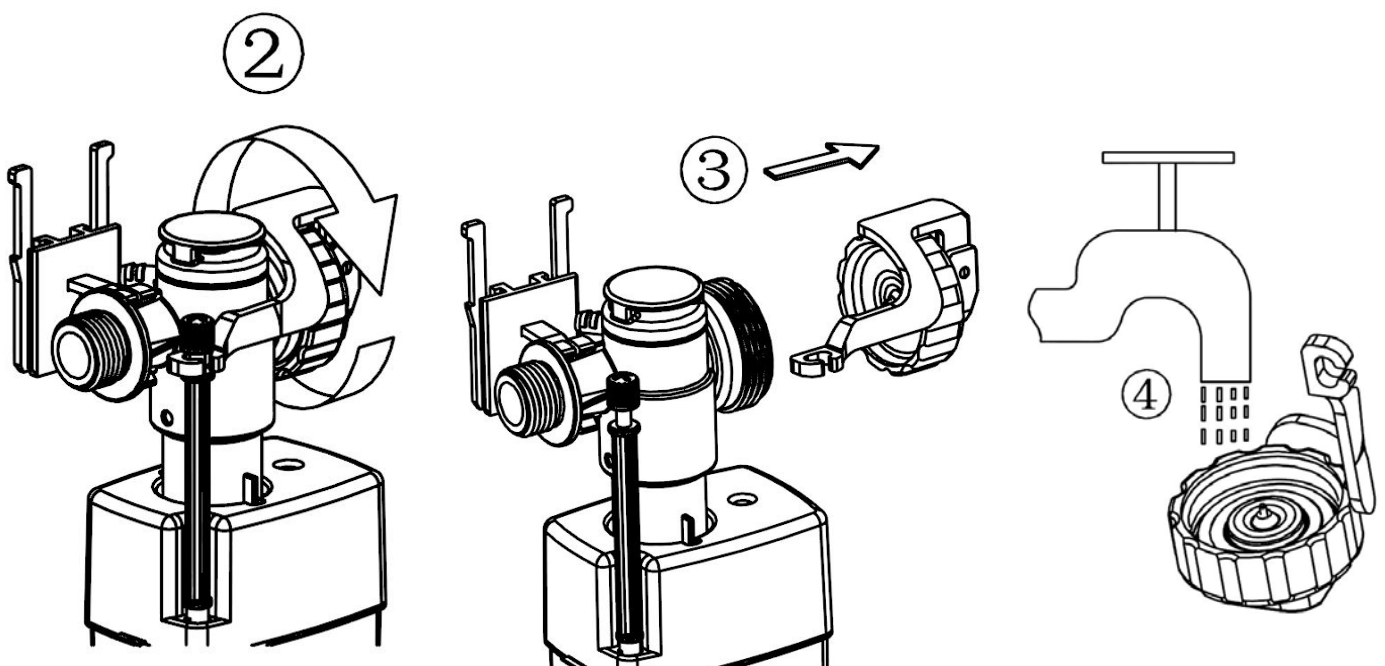

### 1.3 Installing the inlet valve

Follow the 1-3 steps on the drawings.

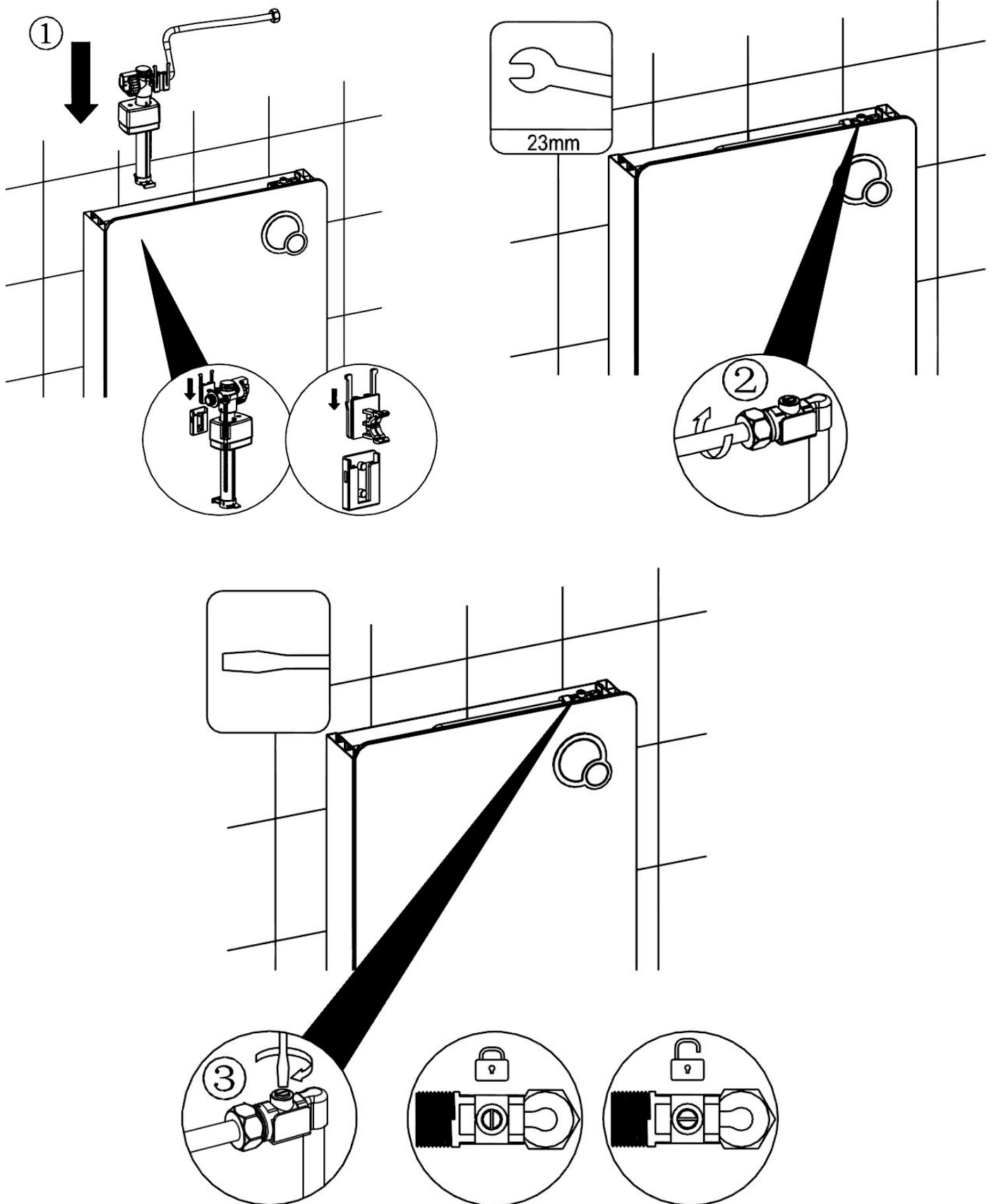

## 2.1 Removing the flush valve

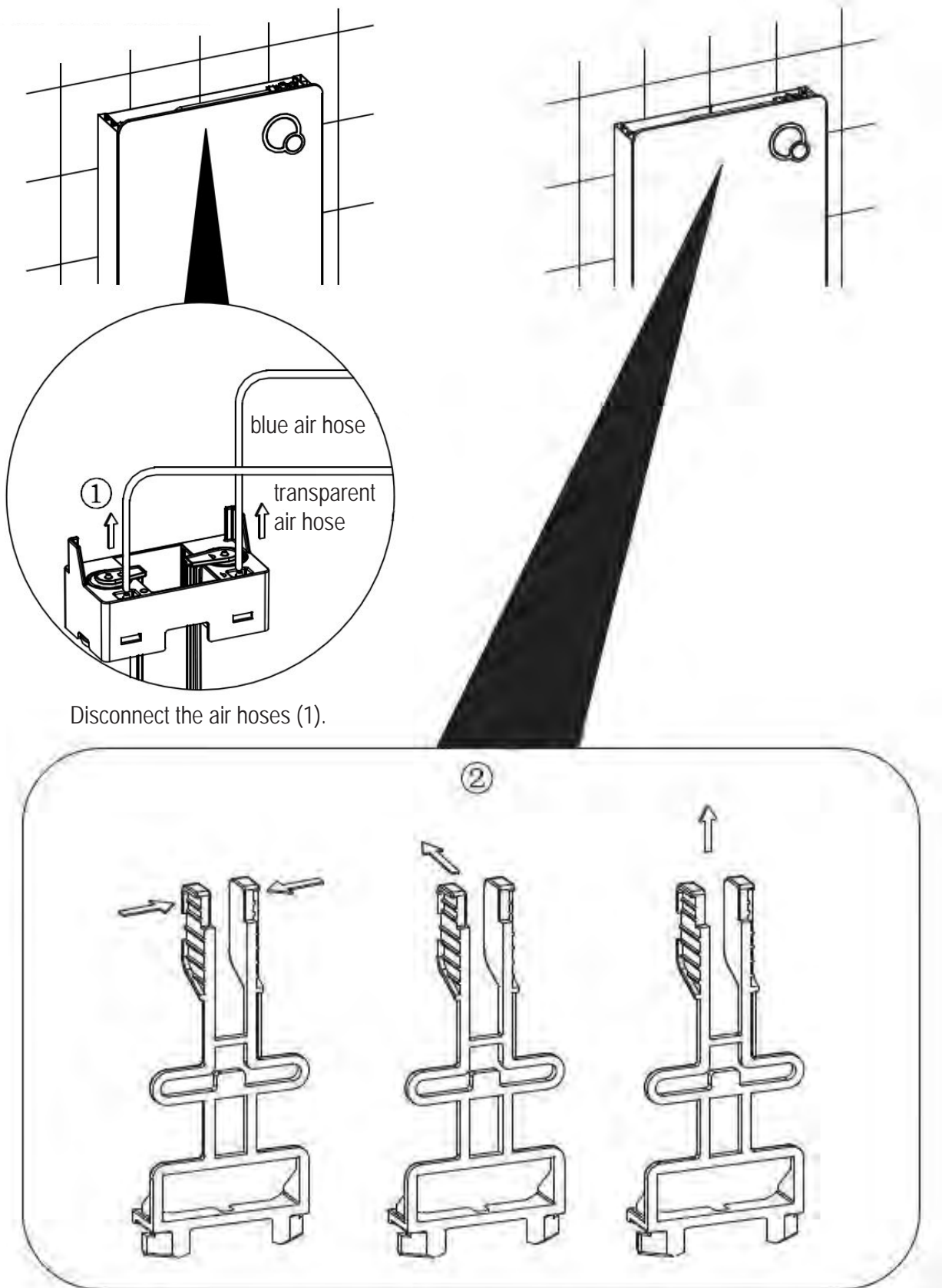

Disconnect the air hoses (1).

Remove the lever (2).

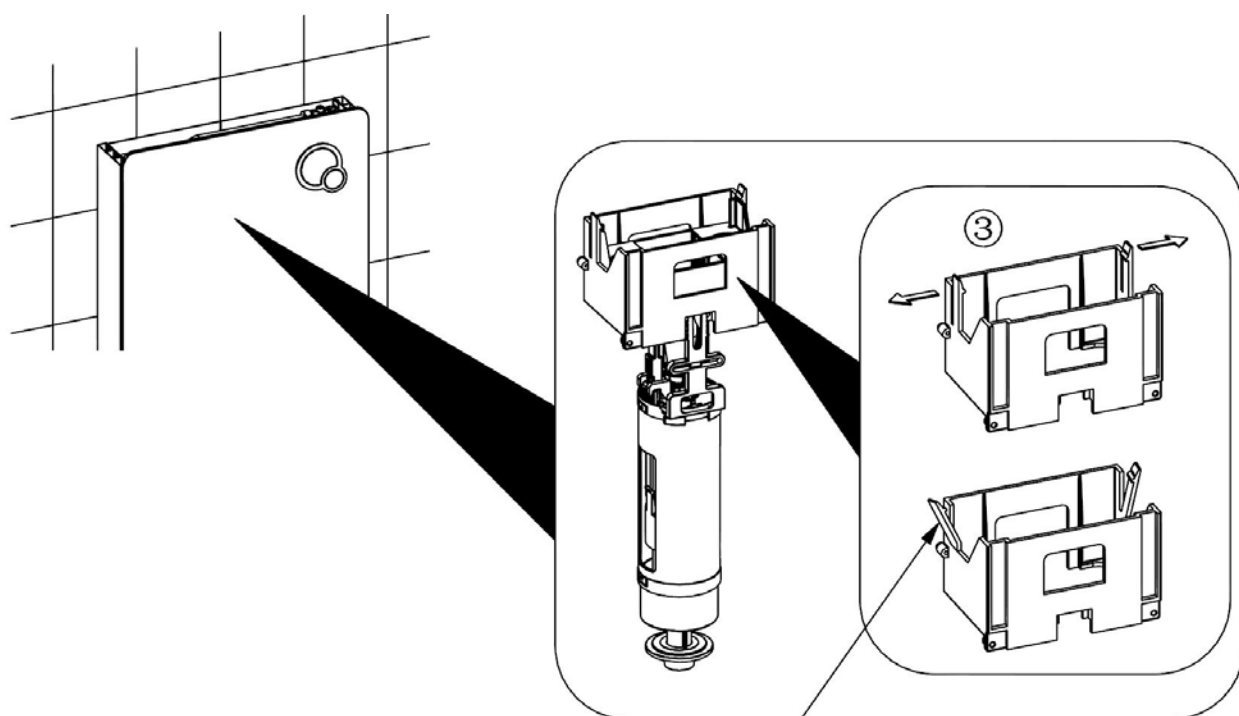

Clamps of the suspension device.

After having opened the hanger locks (3), lift the flush valve upwards (4).

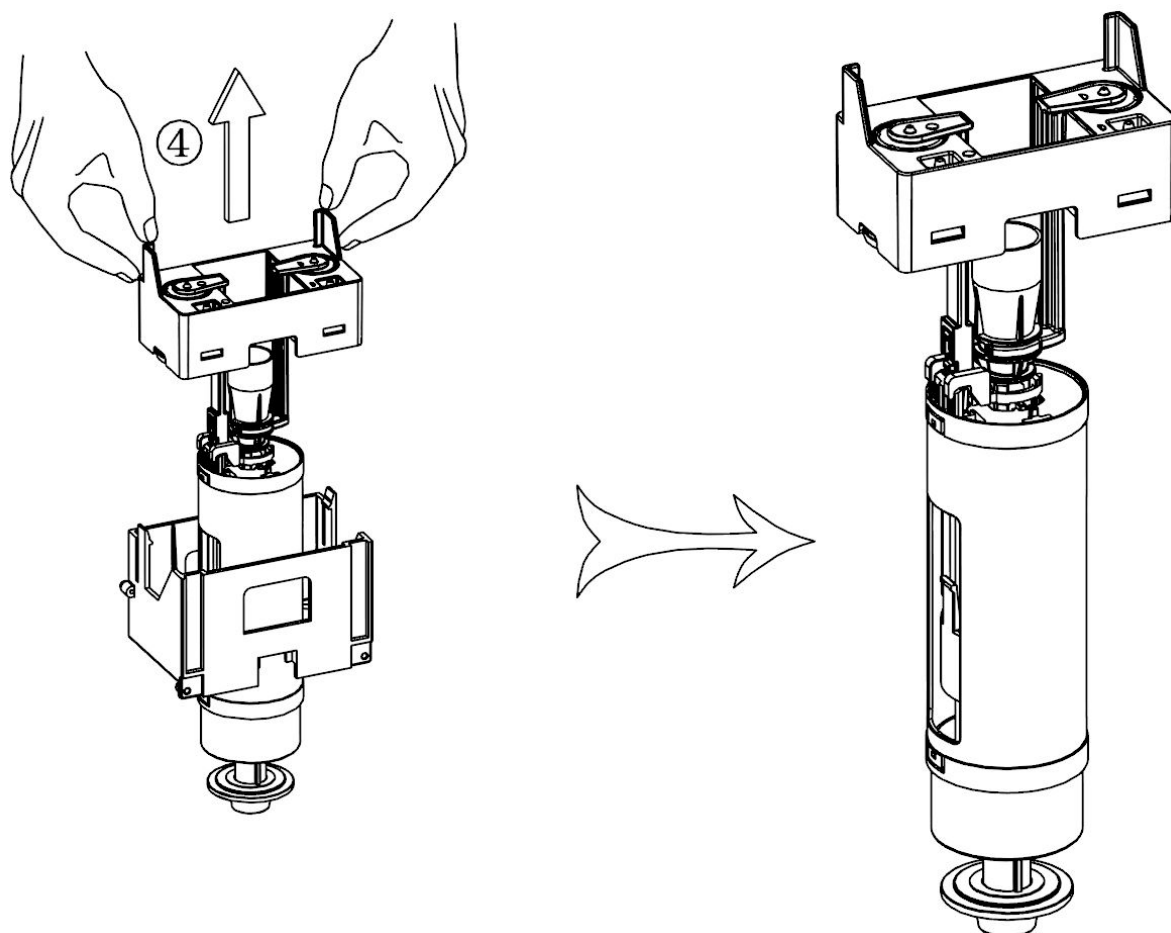



## 2.2 Setting and cleaning the flush valve

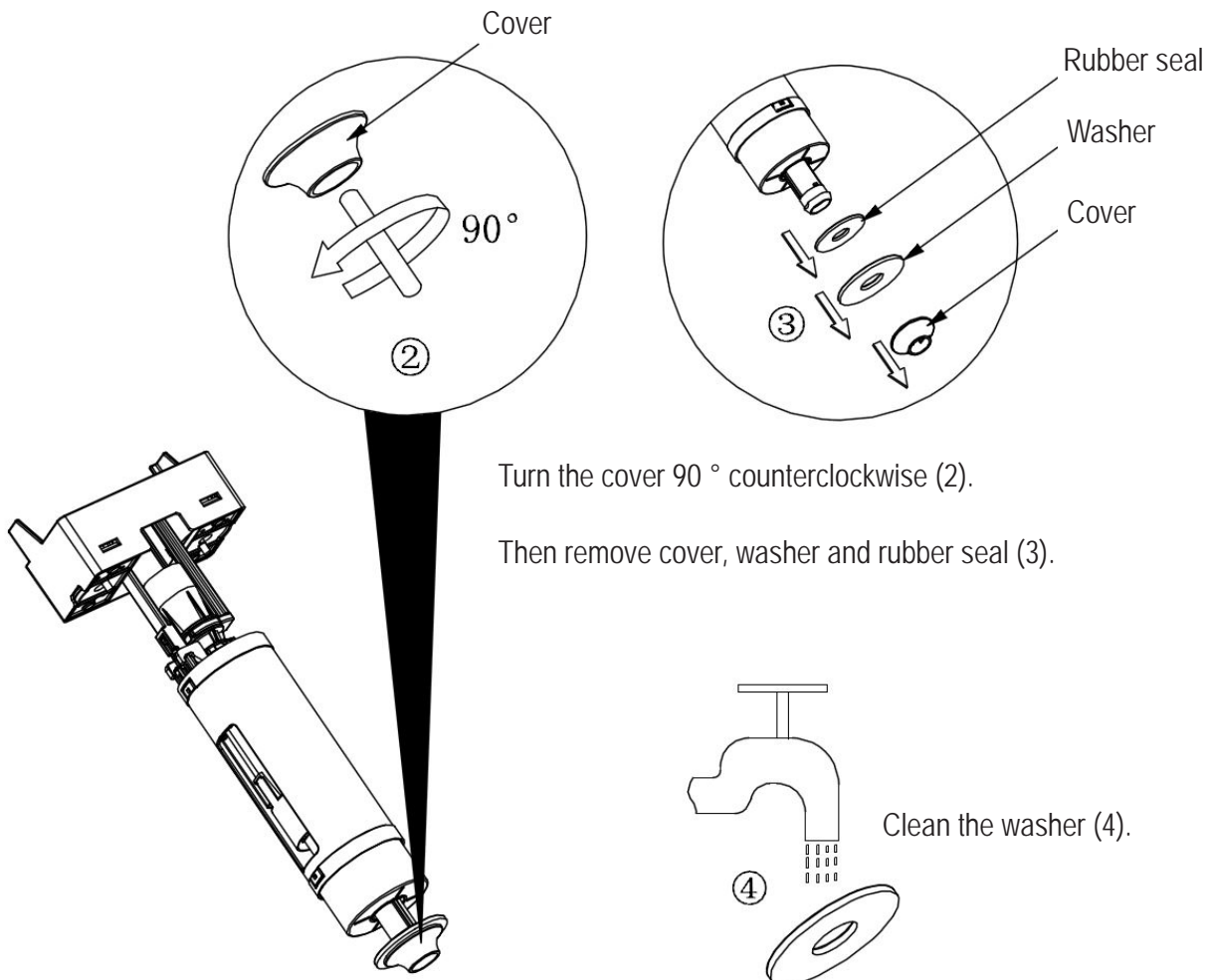
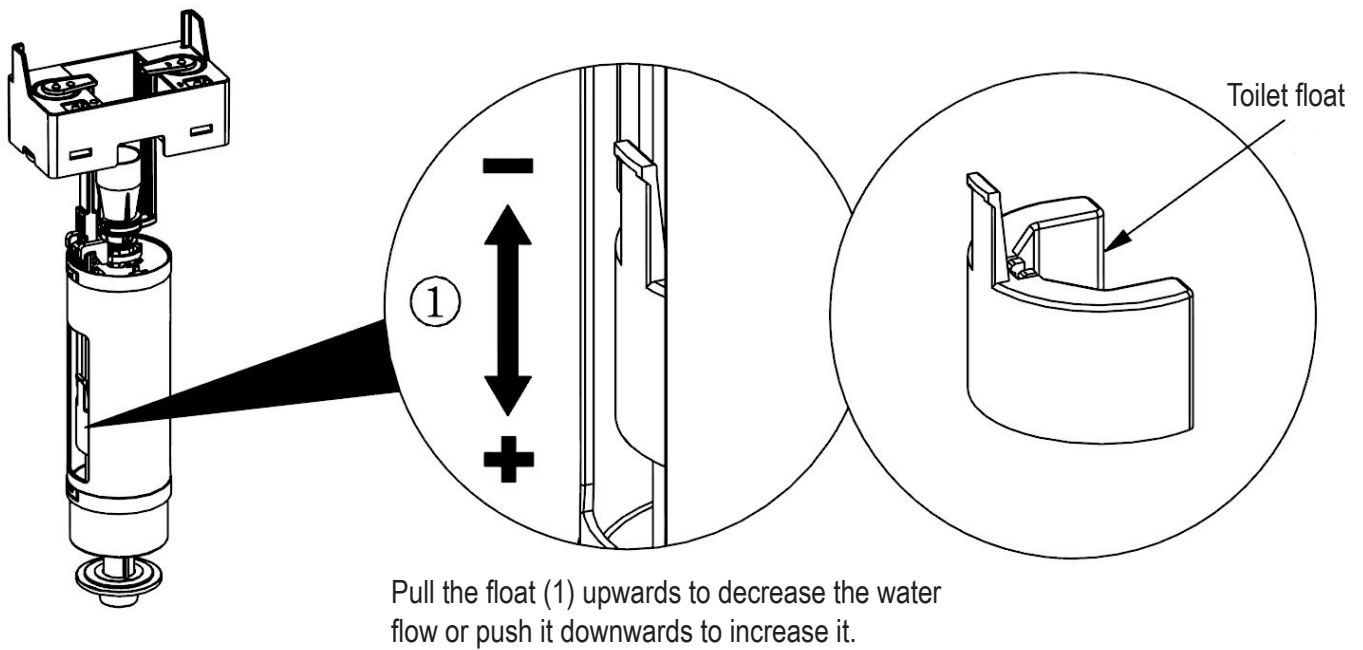

## 2.3 Installing the purge valve

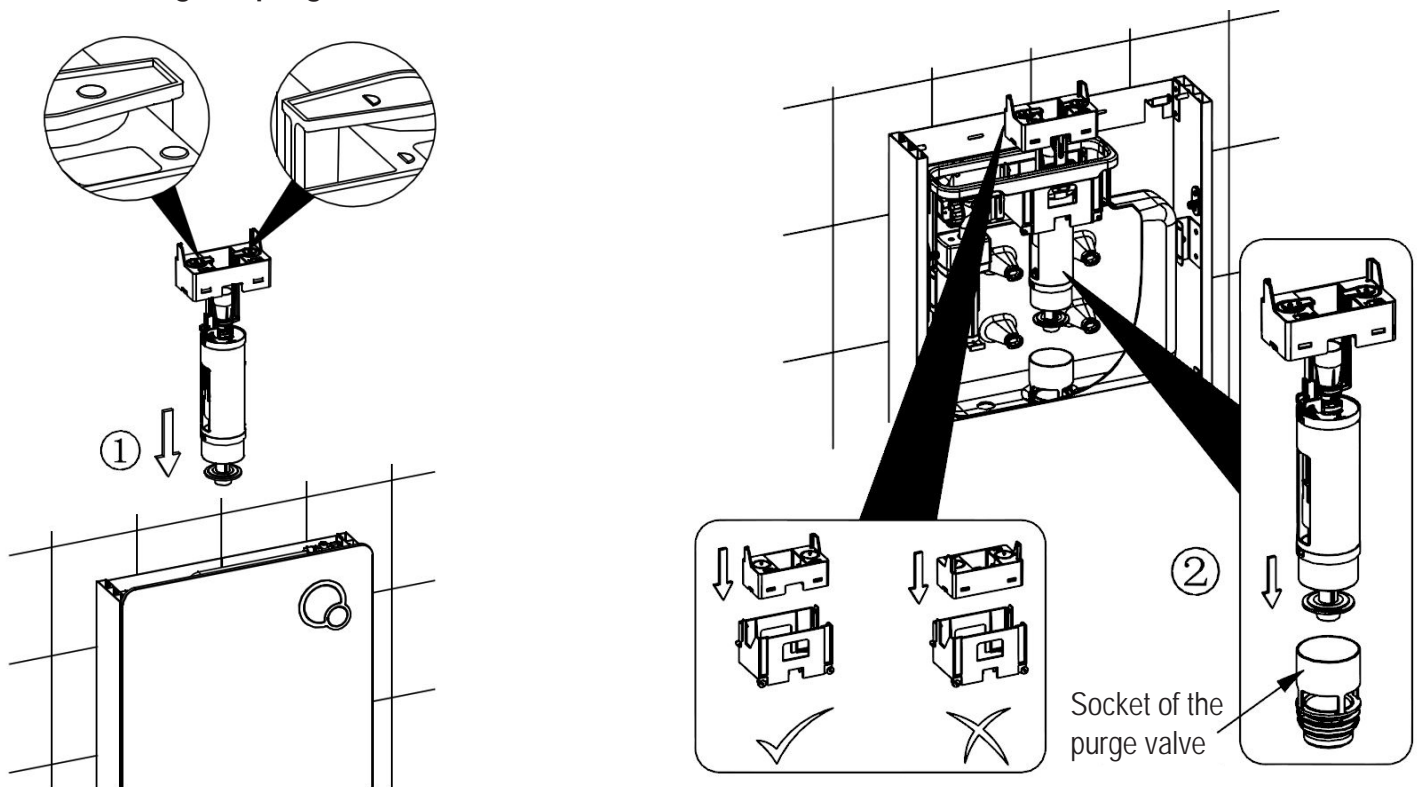

Mount the flushing valve from top to bottom in the sanitary module (1).  
**Attention:** The bottom of the purge valve must be fitted in its base (2).  
 Make sure that the purge valve is mounted as shown in the direction shown.

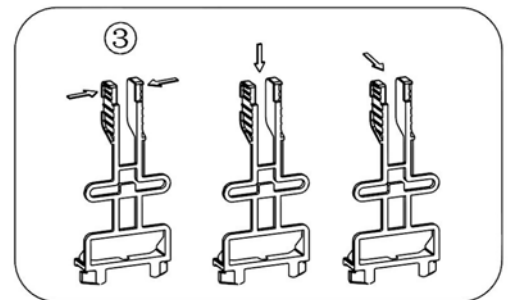
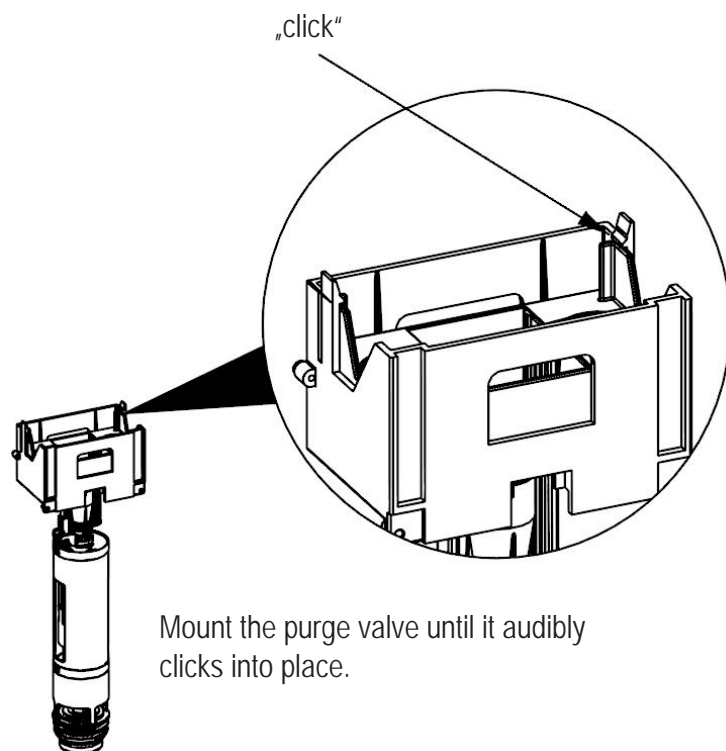

Mount the lever (3).

Attach the glass cover (4).

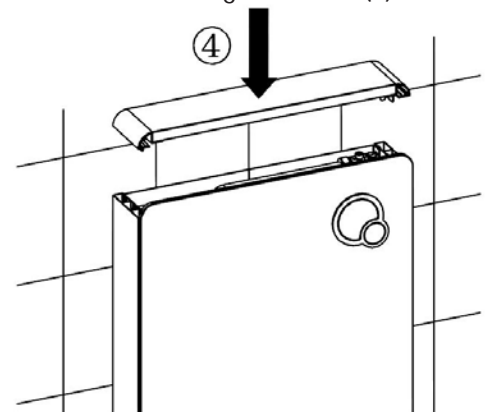

**DE** WARTUNG:

1. Nutzen Sie ausschließlich weiche Tücher und klares Wasser, um das Profil und die Glasfront des Sanitärmoduls zu reinigen.
2. Bitte nutzen Sie keine ätzenden Chemikalien oder Mittel, zur Reinigung.
3. Vermeiden Sie die Reinigung mit scharbenden Gegenständen. Hartnäckige Flecken können Sie mit niedrigkonzentriertem Essig reinigen, spülen Sie im Anschluss mit viel Wasser nach.
4. Wischen Sie regelmäßig mit einem feuchtem Baumwolltuch über das Glaspaneel.
5. Bitte säubern Sie das Sanitärmodul nicht mit Toilettenreiniger. Falls versehentlich Toilettenreiniger auf das Modul spritzen sollte, spülen Sie umgehend die Stellen mit klarem Wasser ab.

**EN** MAINTENANCE:

1. Use only soft cloths and clear water to clean the profile and glass front of the sanitary module.
2. Please do not use caustic chemicals or agents for cleaning.
3. Avoid cleaning with abrasive objects. Stubborn stains can be cleaned with low-concentrated vinegar, then rinse with plenty of water.
4. Wipe regularly with a damp cotton cloth over the glass panel.
5. Please do not clean the sanitary module with toilet cleaner. If toilet cleaner should accidentally splash on the module, immediately rinse the area with clean water.

**FR** ENTRETIEN:

1. Utilisez uniquement des chiffons doux et de l'eau claire pour nettoyer le profilé et la façade en verre du module sanitaire.
2. Veuillez ne pas utiliser de produits chimiques caustiques ni d'agents de nettoyage.
3. Évitez de nettoyer avec des objets abrasifs. Les taches rebelles peuvent être nettoyées avec du vinaigre faiblement concentré, puis rincées à grande eau.
4. Essuyez régulièrement avec un chiffon de coton humide sur le panneau de verre.
5. Veuillez ne pas nettoyer le module sanitaire avec un nettoyant pour toilettes. Si le nettoyant pour toilettes éclabousse accidentellement le module, rincez immédiatement la zone à l'eau claire.

**IT** MANUTENZIONE:

1. Usare solo panni morbidi e acqua pulita per pulire il profilo e la parte anteriore in vetro del modulo sanitario.
2. Si prega di non utilizzare prodotti chimici caustici o agenti per la pulizia.
3. Evitare di pulire con oggetti abrasivi. Le macchie ostinate possono essere pulite con aceto a bassa concentrazione, quindi risciacquare con abbondante acqua.
4. Pulisci regolarmente con un panno di cotone umido sul pannello di vetro.
5. Se il detergente si rovescia accidentalmente sul modulo, sciacquare immediatamente l'area con acqua pulita.



## DE ERKLÄRUNG

Die Bedienungsanleitung dient nur als Referenz. Diese Anleitung kann abweichende Angaben enthalten. Die beschriebenen Produkte können jederzeit aktualisiert werden. Die Zeichnungen in dieser Anleitung dienen nur zur Darstellung und haben keinen Anspruch auf Aktualität.

## EN STATEMENT

This instructions should only be considered as a standard manual. Modifications applied to updated version of the product might not be mentioned inside this document. In this case, please just use the manual as a reference. The company reserves modification rights.

## FR EXPLICATIONS

Les renseignements figurant dans cette notice de montage ne sont communiqués qu'à titre d'information et peuvent être mis à jour sans préavis. Toutes les figures et dessins présents dans ces instructions sont uniquement à titre d'illustration et n'ont aucune valeur d'actualité.

## IT DICHIARAZIONE

Il seguente manuale è solo una guida standard. Nel caso in cui dovessero essere presenti errori, dovuti a eventuali modifiche postume del prodotto, si prega di considerare il manuale unicamente come riferimento per il montaggio. L'azienda si riserva il diritto di modifica.