

Duscharmatur NT7306/ NT7306B ○

Shower Mixer NT7306/ NT7306B ○

Mitigeur NT7306/ NT7306B ○

Miscelatore NT7306/ NT7306B ○

DE EN FR IT

BERNSTEIN 



MONTAGEANLEITUNG - IV / 2019

ASSEMBLY INSTRUCTIONS / NOTICE DE MONTAGE / ISTRUZIONI DI MONTAGGIO

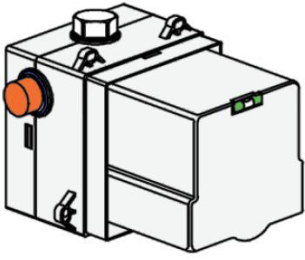

1

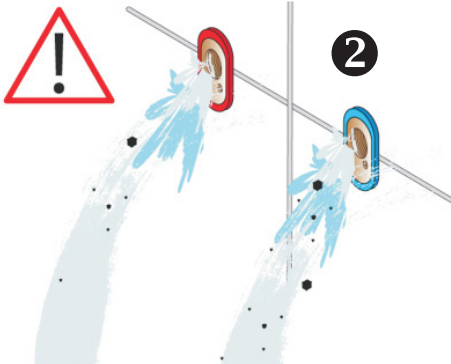
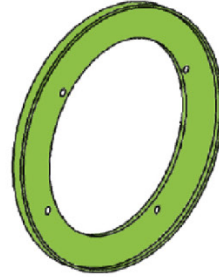
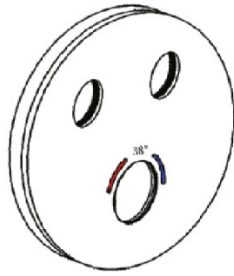

2

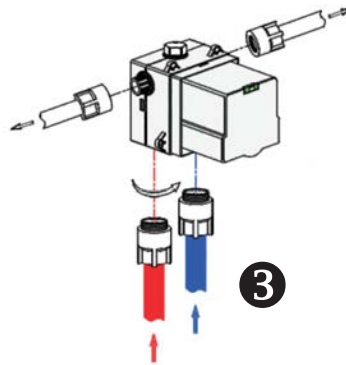

3

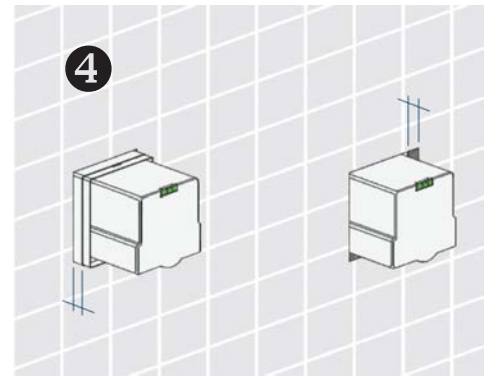

4

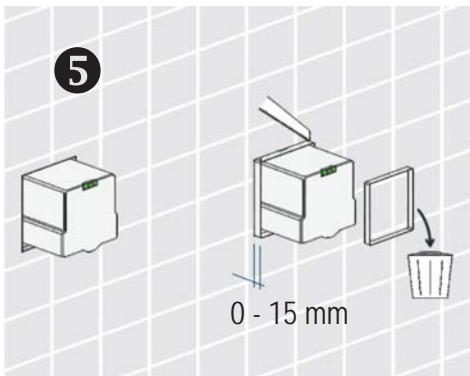

5

0 - 15 mm

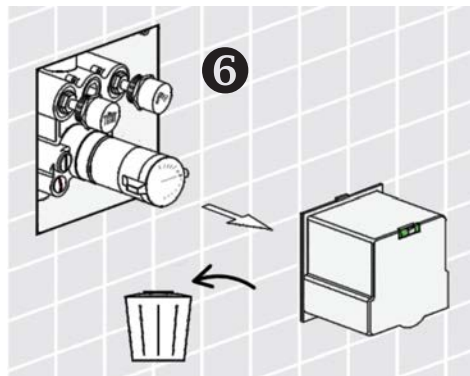

6

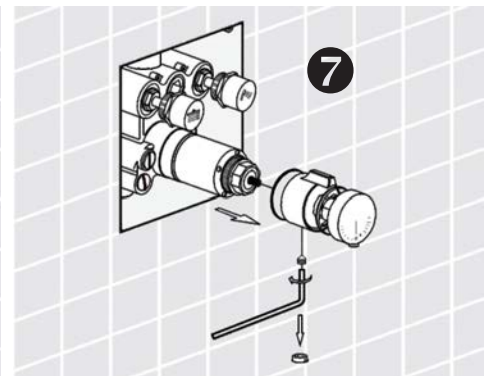

7

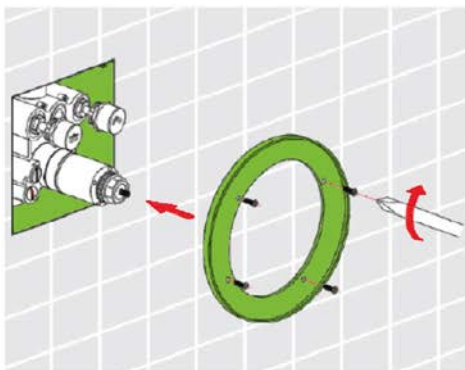

8

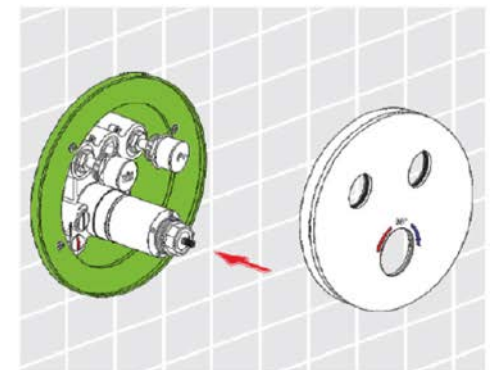
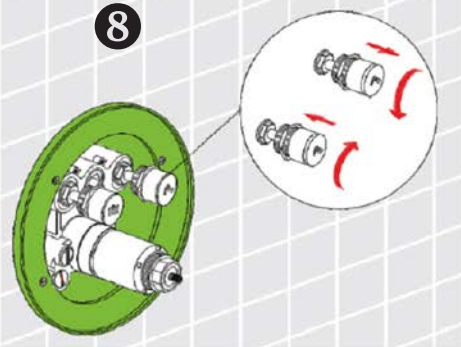

DE HINWEISE:

1. Achten Sie auf waagerechten Einbau. Wasserwaage integriert.
2. Spülen Sie die Wasserleitungen vor der Installation, um Fremdkörper auszuschwemmen.
3. Der Anschluss für heißes Wasser erfolgt links und der für kaltes Wasser rechts.
4. Der Spielraum für die Montage darf weder über- noch unterschritten werden.
5. Der Montagespielraum beträgt 0 - 15 mm.
6. Entfernen Sie die Schutzabdeckung.
7. Demontieren Sie den Armaturengriff in der dargestellten Position.
8. Befestigen Sie den Halterahmen und die Glasblende wie abgebildet.

EN NOTE:

1. Pay attention to horizontal installation.
2. Rinse the water pipes prior to installation to flush out foreign objects.
3. The connection for hot water is on the left and for cold water on the right.
4. The scope for assembly must not be exceeded or fallen short of.
5. The mounting range is 0 - 15 mm.
6. Remove the protective cover.
7. Disassemble the fitting handle in the position shown.
8. Attach the mounting frame and the glass panel as shown.

FR REMARQUES:

1. Faites attention à l'installation horizontale.
2. Rincez les conduites d'eau avant l'installation pour éliminer les corps étrangers.
3. La connexion pour l'eau chaude est à gauche et pour l'eau froide à droite.
4. Une limite inférieure et une limite supérieure de marge pour le montage ne doit pas être dépassée.
5. La marge de montage est de 0 à 15 mm.
6. Retirez le couvercle de protection.
7. Démontez la poignée de montage dans la position indiquée.
8. Fixez le cadre de montage et le panneau de verre comme indiqué.

IT NOTA:

1. Prestare attenzione all'installazione orizzontale.
2. Risciacquare i tubi dell'acqua prima dell'installazione per rimuovere corpi.
3. La connessione per l'acqua calda è a sinistra e per l'acqua fredda a destra.
4. Il campo di applicazione per il montaggio non deve essere superato o ridotto.
5. La distanza di montaggio è compresa tra 0 e 15 mm.
6. Rimuovere il coperchio protettivo.
7. Smontare la maniglia del raccordo nella posizione mostrata.
8. Fissare il telaio di montaggio e il pannello di vetro come mostrato.

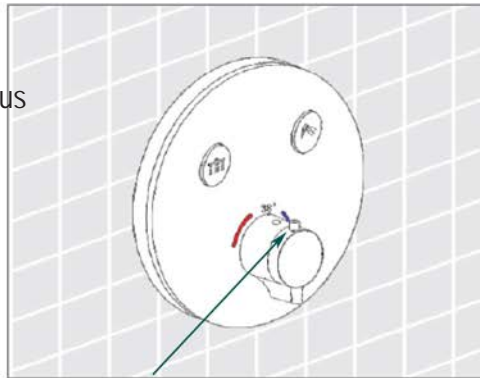
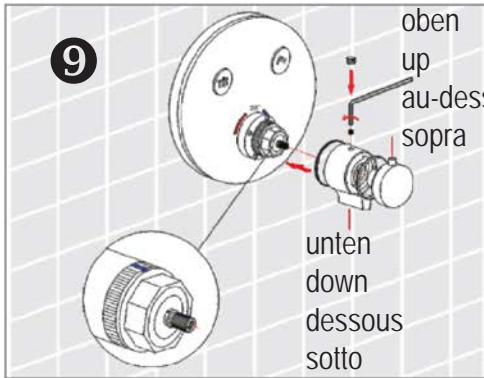

Sicherheitsentriegelung
Safety release
Fermeture de sécurité
Chiusura di sicurezza

Verbraucher wechseln
Change consumers
Changez les fonctions
Cambia le funzioni

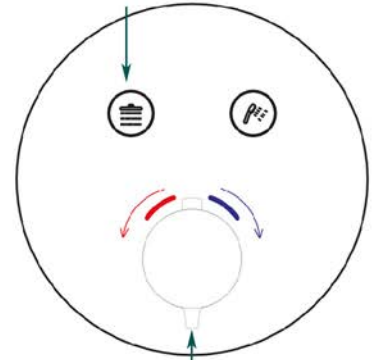

Durchflussmenge Steuerung, Flow rate control,
Contrôle du débit, Controllo della portata.

10

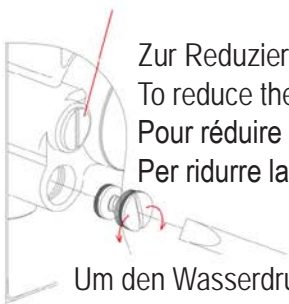

Zur Reduzierung des Wasserdrucks bis zum Absperrren im Uhrzeigersinn drehen.

To reduce the water pressure, turn it clockwise until it shuts off.

Pour réduire la pression de l'eau, tournez-le dans le sens des aiguilles d'une montre jusqu'à ce qu'il s'éteigne.

Per ridurre la pressione dell'acqua, ruotarla in senso orario fino allo spegnimento.

Um den Wasserdruck zu erhöhen, gegen den Uhrzeigersinn drehen.

To increase the water pressure turn counterclockwise.

Pour augmenter la pression de l'eau, tornez dans le sens inverse des aiguilles d'aiguille d'une montre.

Per aumentare la pressione dell'acqua, ruotare in senso antiorario.



DE HINWEISE:

9. Montieren Sie den Armaturengriff in der abgebildeten Position.
10. Im Filter sammeln sich Verunreinigungen wie Sand und Kies.

EN NOTE:

9. Mount the fitting handle in the position as shown.
10. The filter collects impurities such as sand and gravel.

FR REMARQUES:

9. Montez la poignée de montage dans la position indiquée.
10. Dans le filtre s'accumulent des impuretés telles que sable ou gravier.

IT NOTA:

9. Montare la maniglia di montaggio nella posizione mostrata.
10. Nel filtro si accumulano impurità come sabbia o ghiaia.