

STÜTZKLAPPGRIFF NT600

FOLDING SAFETY RAIL NT600

EMBAYAGE SUPPORT NT600

AUSILIO DI SICUREZZA RIBALTABILE NT600

DE EN FR IT

BERNSTEIN 

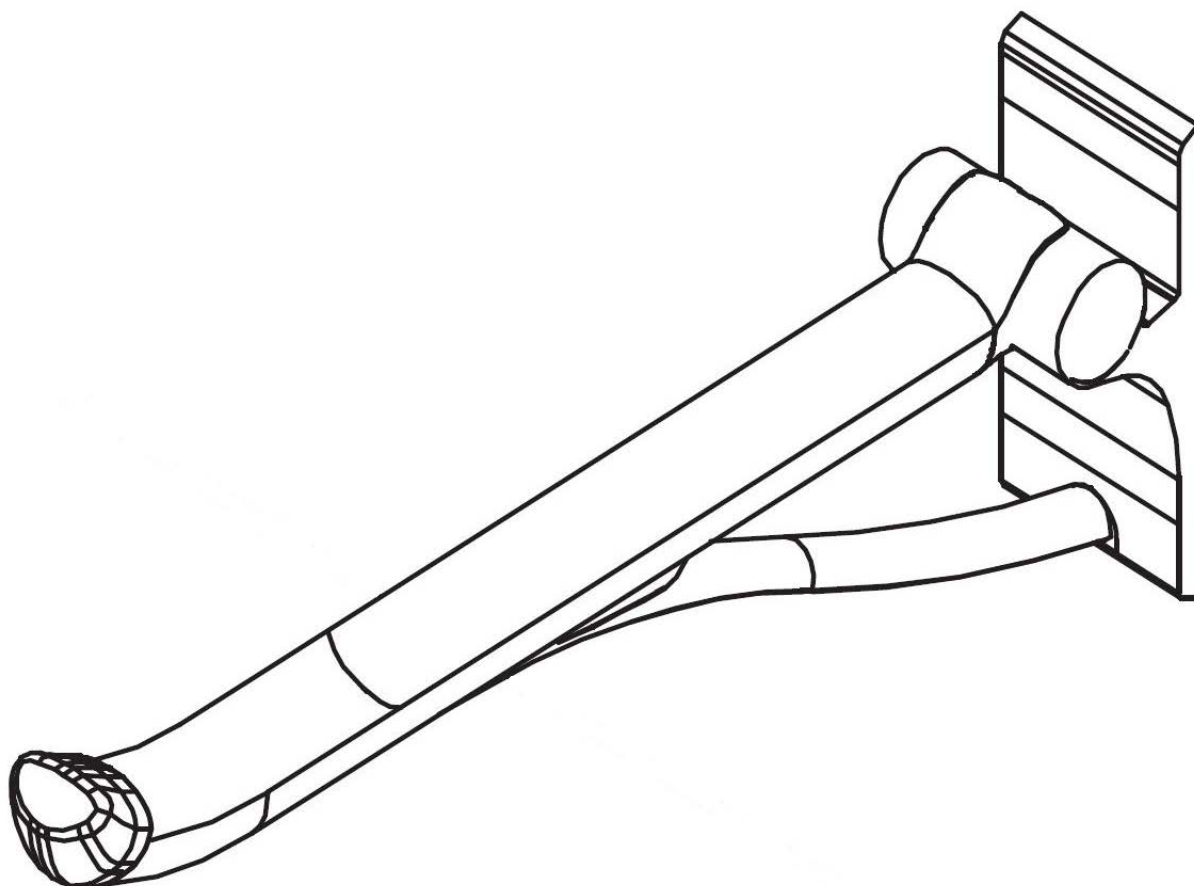

MONTAGEANLEITUNG - II / 2018

ASSEMBLY INSTRUCTIONS / NOTICE DE MONTAGE / ISTRUZIONI DI MONTAGGIO

## LIEFERUMFANG

DELIVERY / CONTENU DE LA LIVRAISON / CONTENUTO DELLA CONSEGNA

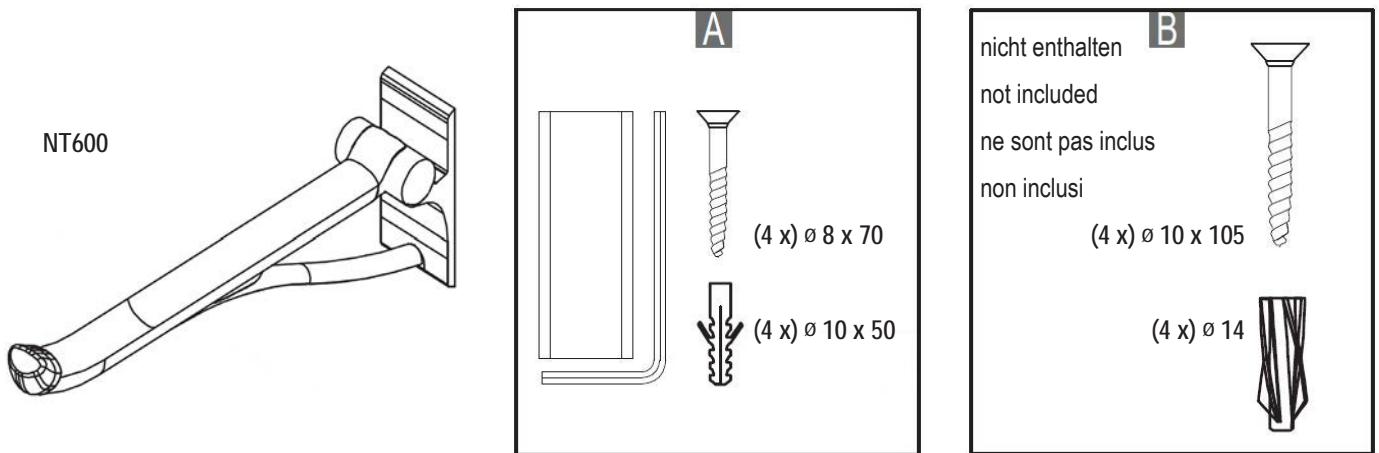
**DE** HINWEIS:

Vor Montage des Produkts prüfen Sie die Tragfähigkeit der Wände. Schrauben und Dübel für Gasbetonwände wie in Zeichnung B angegeben sind nicht im Lieferumfang enthalten.

**EN** NOTE:

Before installing the product, make sure to double check the wall's load capacity. Screws and finshers for aerated autoclaved concrete walls are not included in the delivery as indicated in the above B drawing.

**FR** REMARQUES:

Avant de monter le produit, vérifiez la capacité de charge des murs. Les vis et les chevilles pour les murs en béton cellulaire, comme indiqué sur le dessin B, ne sont pas inclus.

**IT** NOTA:

Prima di montare il prodotto, verificare la capacità di carico delle pareti. Viti e tasselli per pareti in calcestruzzo aerato autoclavato, come indicato nel disegno B, non sono inclusi in consegna.

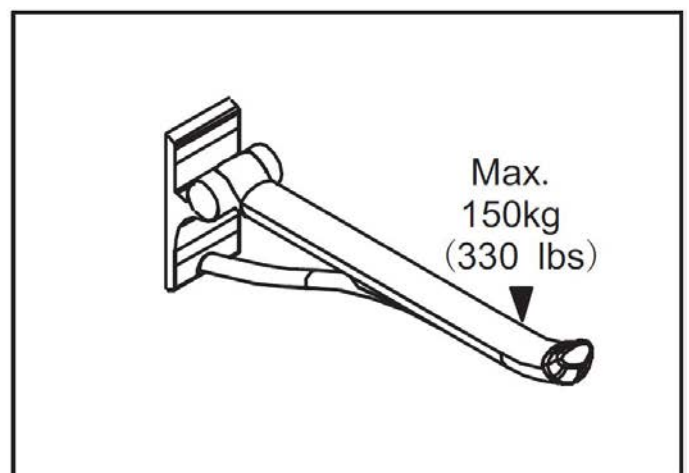
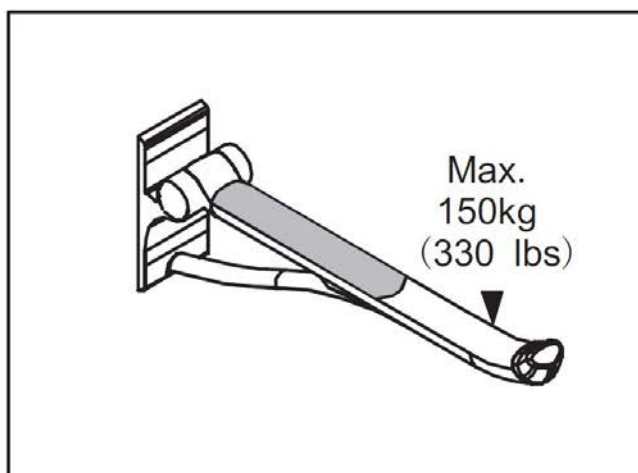

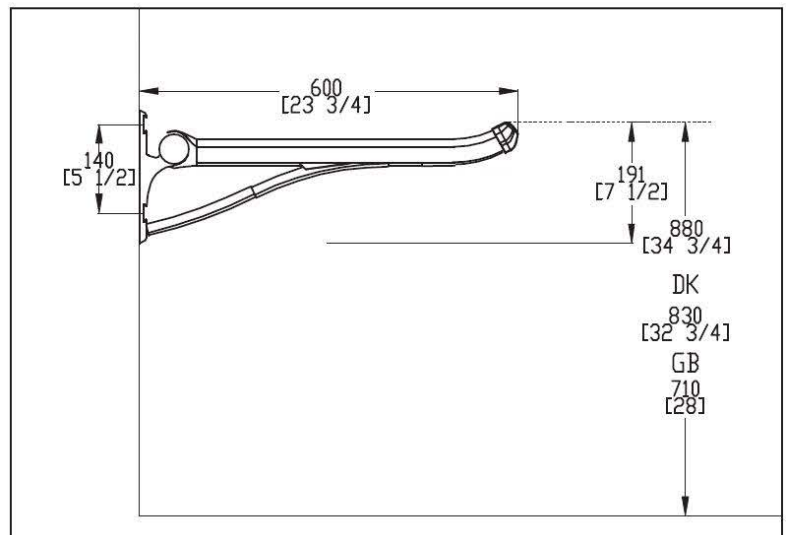
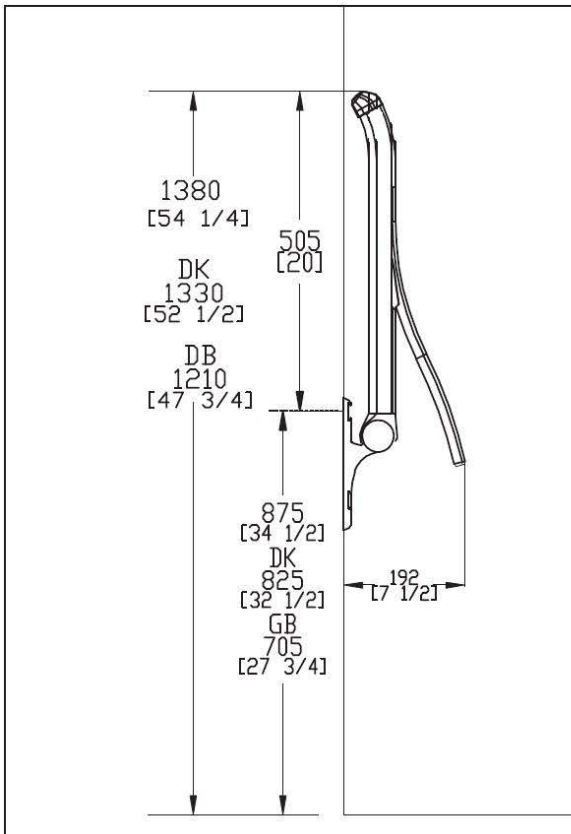
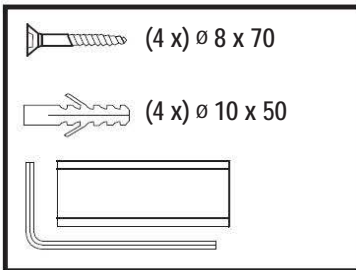
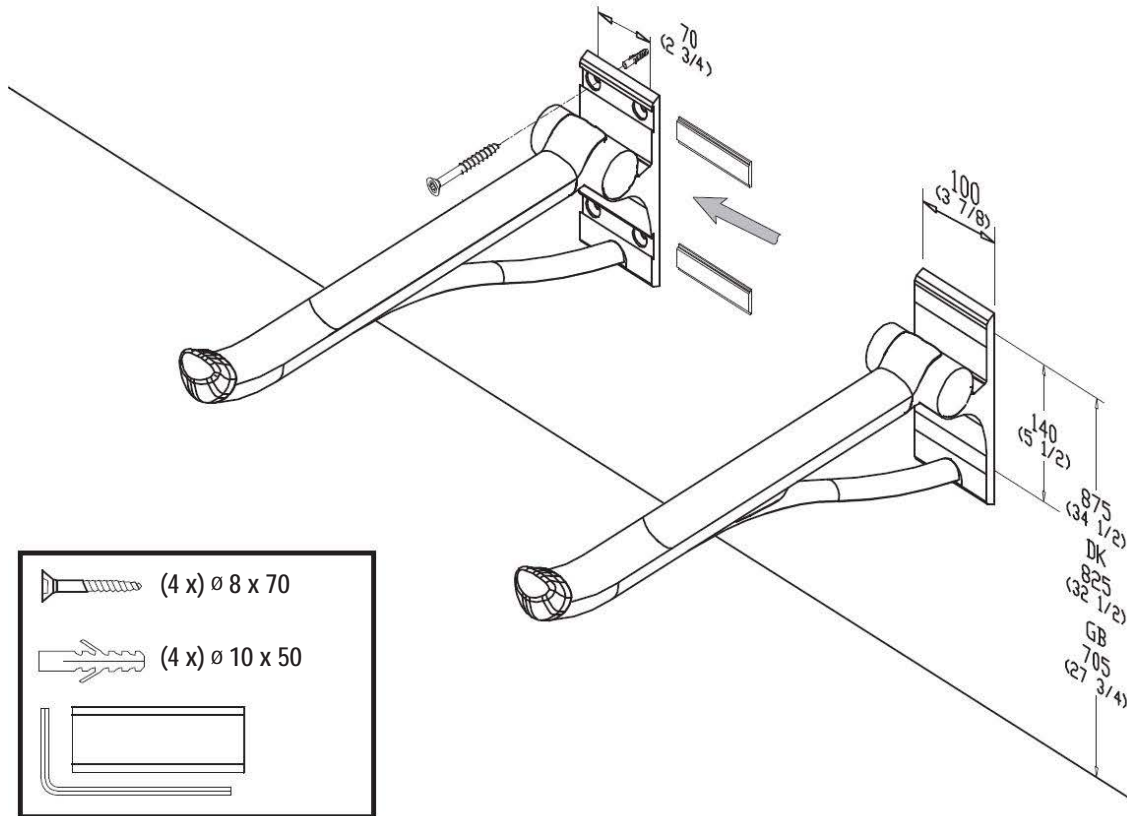



## DE ERKLÄRUNG

Die Bedienungsanleitung dient nur als Referenz. Diese Anleitung kann abweichende Angaben enthalten. Die beschriebenen Produkte können jederzeit aktualisiert werden. Die Zeichnungen in dieser Anleitung dienen nur zur Darstellung und haben keinen Anspruch auf Aktualität.

## EN STATEMENT

This instructions should only be considered as a standard manual. Modifications applied to updated version of the product might not be mentioned inside this document. In this case, please just use the manual as a reference. The company reserves modification rights.

## FR EXPLICATIONS

Les renseignements figurant dans cette notice de montage ne sont communiqués qu'à titre d'information et peuvent être mis à jour sans préavis. Toutes les figures et dessins présents dans ces instructions sont uniquement à titre d'illustration et n'ont aucune valeur d'actualité.

## IT DICHIARAZIONE

Il seguente manuale è solo una guida standard. Nel caso in cui dovessero essere presenti errori, dovuti a eventuali modifiche postume del prodotto, si prega di considerare il manuale unicamente come riferimento per il montaggio. L'azienda si riserva il diritto di modifica.