



# Duschsystem NT6185C

Vielen Dank für den Erwerb dieses Produktes.

Lesen Sie vor Montage und Inbetriebnahme der Standarmatur diese Anleitung bitte sorgfältig.

## Lieferumfang

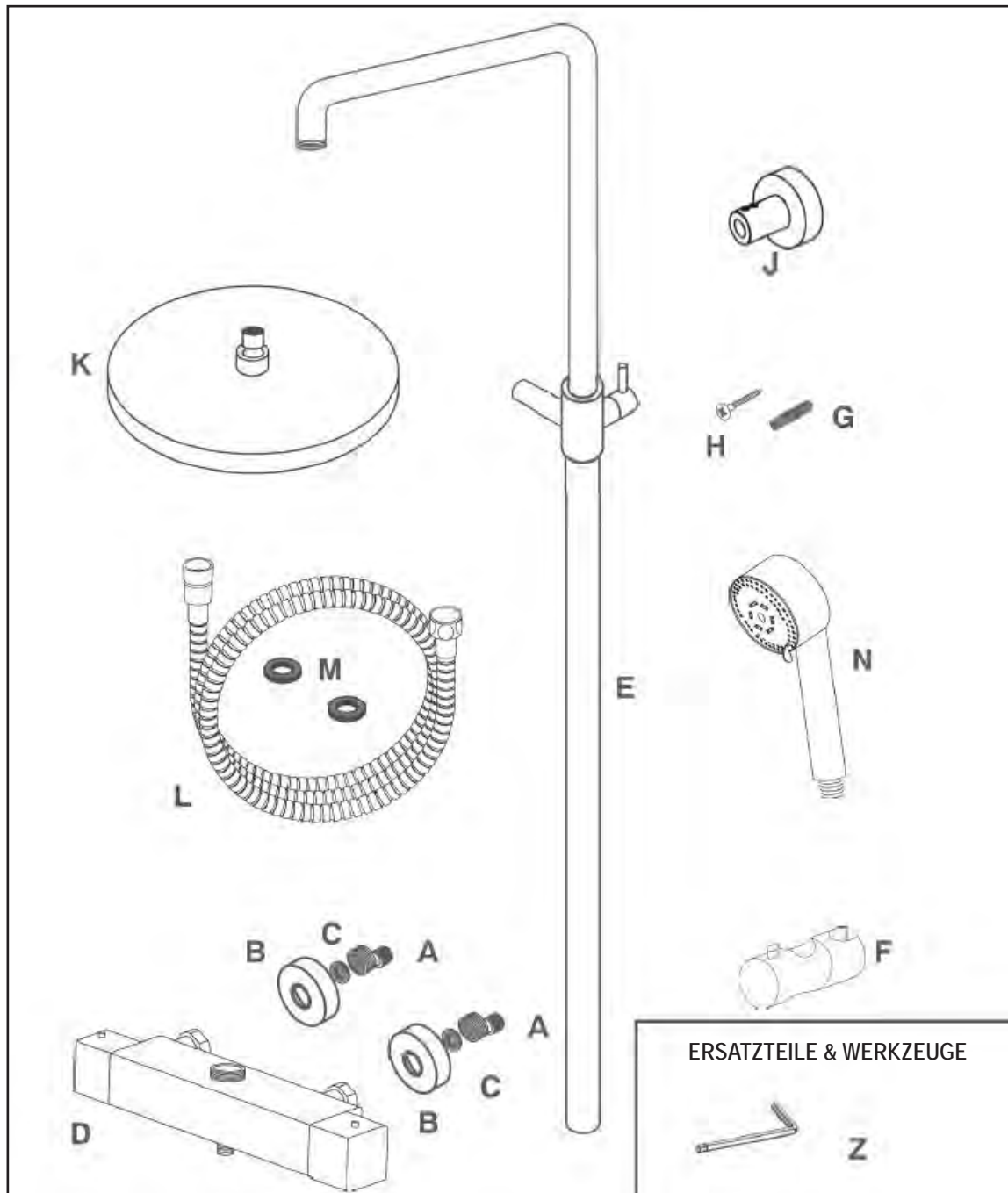

38°C standard

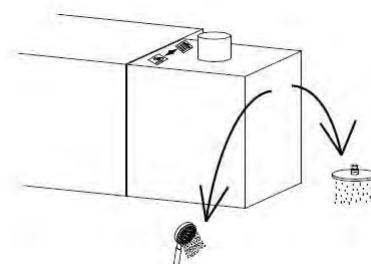
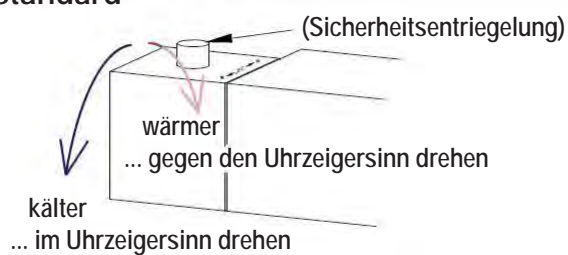

## Montageanleitung I



Spülen Sie die Rohre auch in neuen Anlagen.

In 90 % der Fälle sind Schmutz und Verunreinigungen die Ursache für Probleme bei Armaturen.



1



2

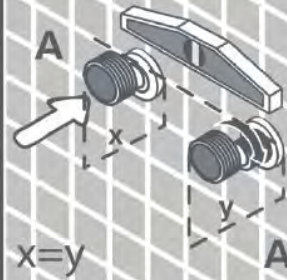

3

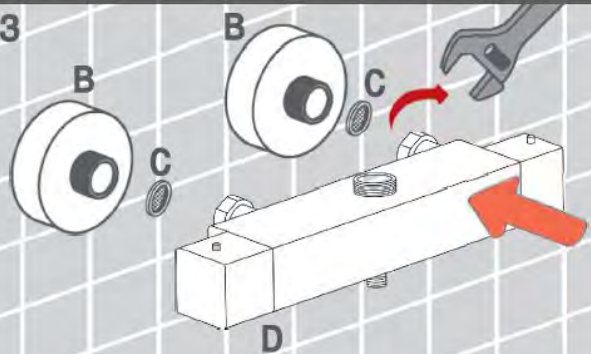

4

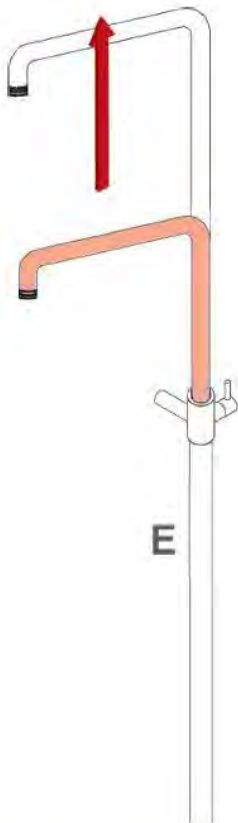

5



6

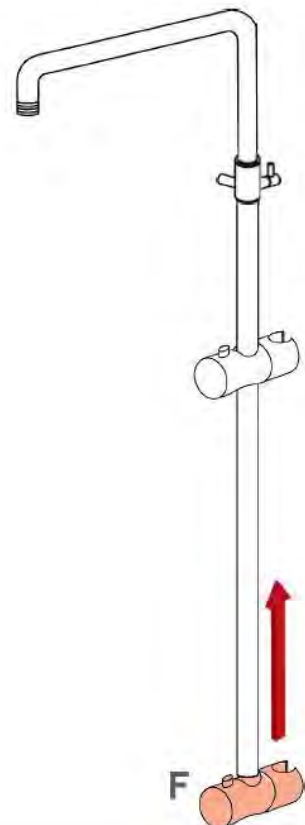

## Montageanleitung II

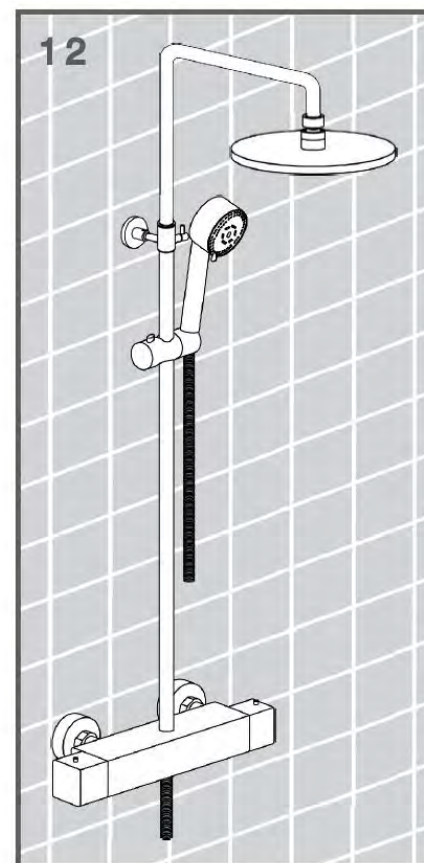
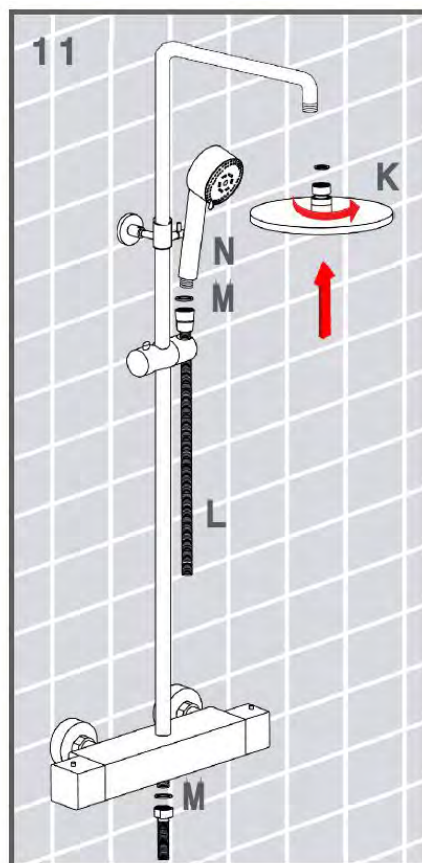
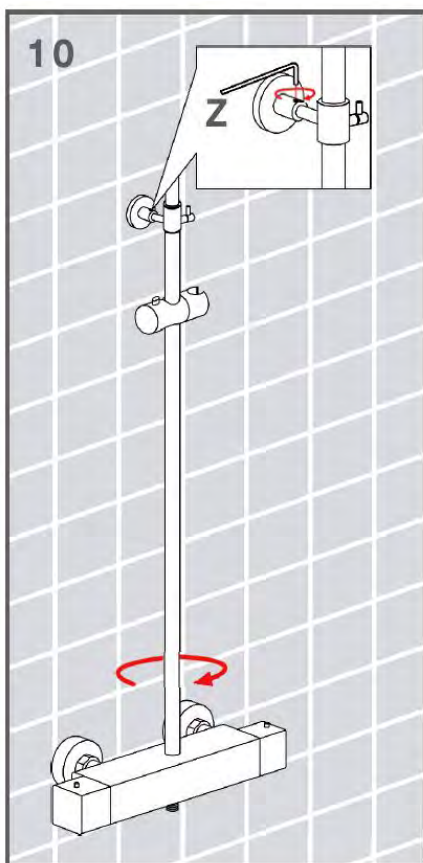
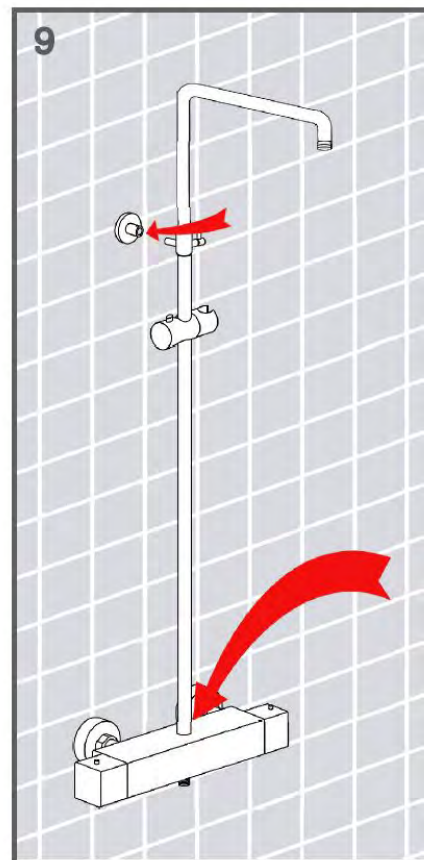
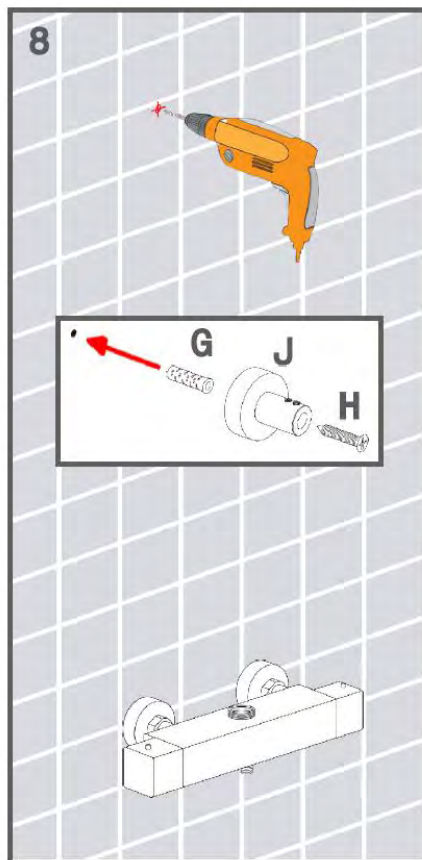
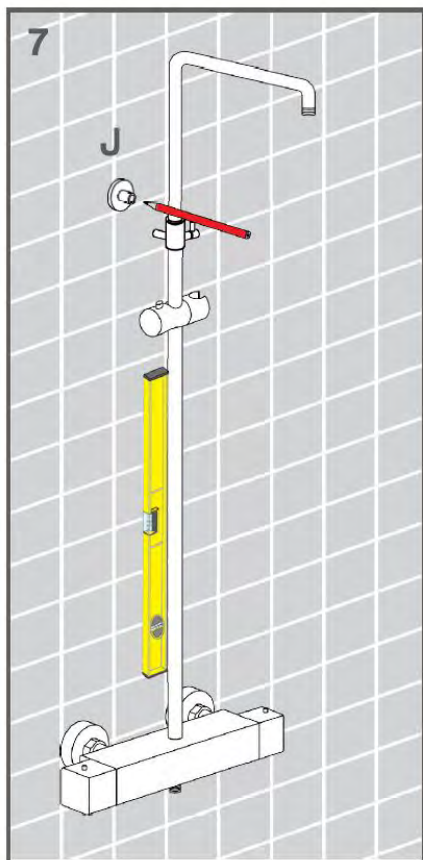



Diese Montageanleitung ist lediglich eine Empfehlung. Bei einer Diskrepanz zwischen Anleitung und dem tatsächlichen Produkt, ist letzteres maßgeblich. Das Recht auf Änderung ist vorbehalten.

## Pflegehinweise

1. Fließt das Wasser aus der Armatur nur schwach, prüfen Sie, ob die Mischdüse oder der Flexschlauch verschmutzt sind. In einem solchen Fall zerlegen Sie dann die entsprechenden Teile und reinigen Sie sie.
2. Benutzen Sie ein weiches Tuch oder Wasser, um die Armatur-Oberfläche zu reinigen. Reinigen Sie die verchromte Oberfläche nicht mit Scheuer- oder scharfen Reinigungsmitteln, andernfalls kann die Oberfläche zerkratzt werden oder korrodieren.
3. Trocknen und polieren Sie die Oberfläche nach jeder Reinigung und nach jeder Benutzung mit einem trockenen, weichen Tuch.

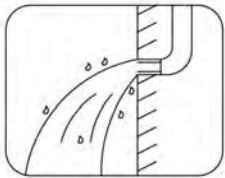

## Von der Garantie sind ausgeschlossen:

- Schäden durch
  - a) eine nicht auf den privaten, häuslichen Nutzung beschränkte Verwendung,
  - b) absichtliche Vernachlässigung,
  - c) eine durch falschen Nutzung entstandene Fehlfunktion,
  - d) fehlerhafte Montage.
- Die Reparaturkosten für durch Fremdkörper oder fremde Substanzen verursachte Schäden.
- Ein Totalverlust des Produkts aufgrund nicht mehr lieferbarer Ersatzteile.
- Entschädigung für einen Nutzungsausfall des Produkts oder Folgeschäden jeglicher Art.
- Anfahrtskosten, wenn kein Fehler am Produkt festgestellt werden konnte.
- Gleichzeitig entstandene Kosten für Reparaturen oder den Austausch von Zubehör.
- Die Kosten für regelmäßige Wartung, Einstellung, Reparatur, Umbau, Verlust oder Beschädigung, die sich daraus ergebenden Kosten, einschließlich der Reparatur von Schäden, Fehlern, Ausfällen durch falschen Gebrauch, Montage oder Wartungskosten.

# SHOWER SYSTEM NT6185C

**BERNSTEIN**  
Living with Style



# INSTRUCTION MANUAL

JUNE 2017

# Shower system NT6185C

Thank you for your purchase!  
Read carefully the following manual before installing or using the mixer.

## Included in the delivery

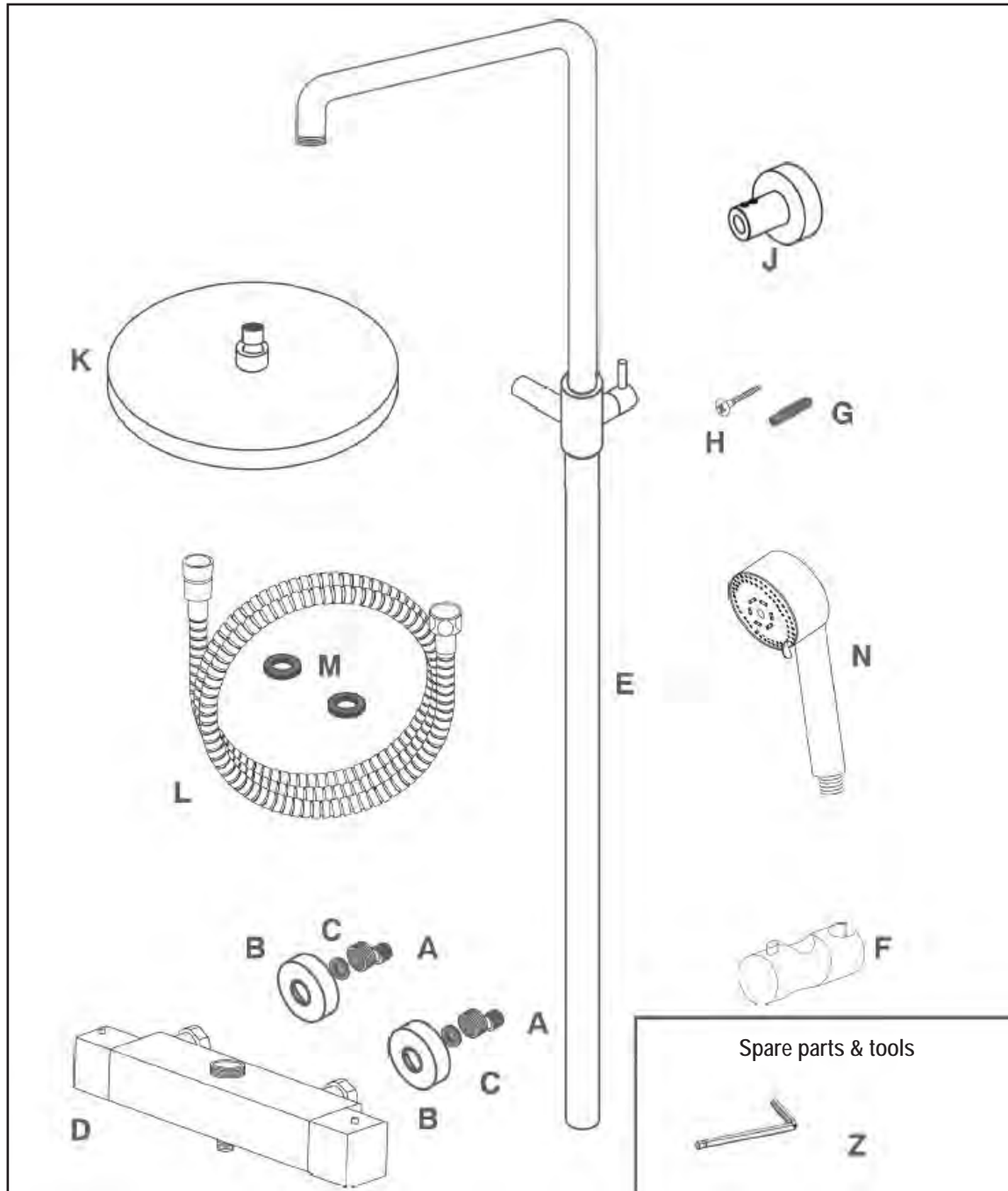

## 38°C standard

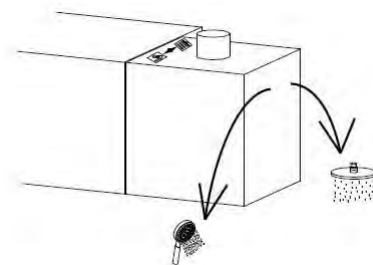
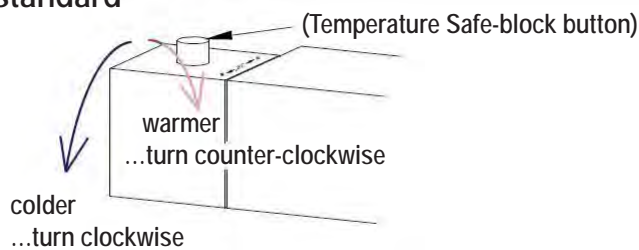

## Assembly instructions I



Wash accurately the pipes even for newly built installation.

Taps problems are 90 % due to dirt and contamination.



1

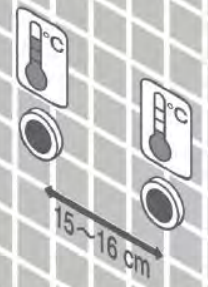

2

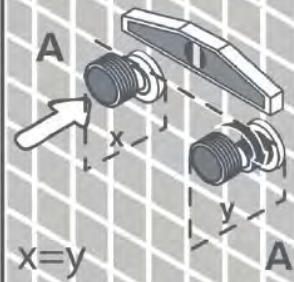

3

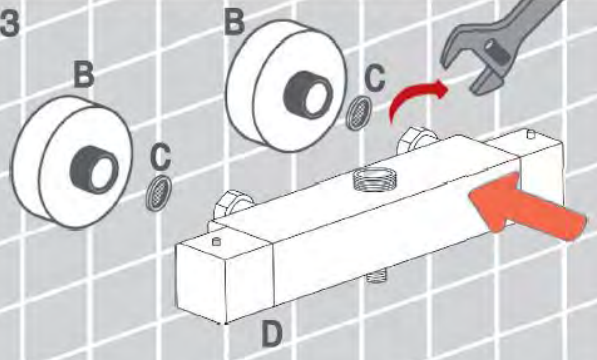

4

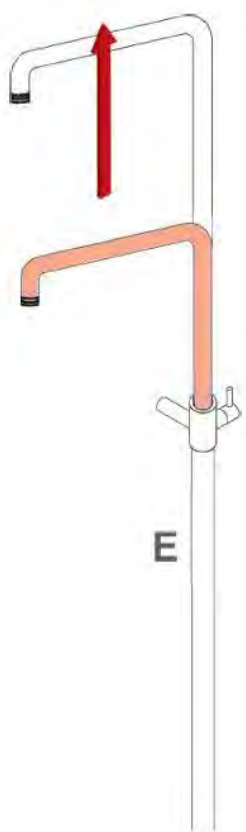

5



6

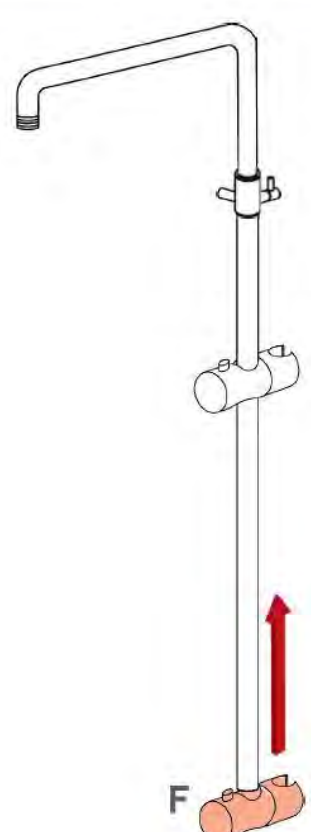



## Assembly instructions II

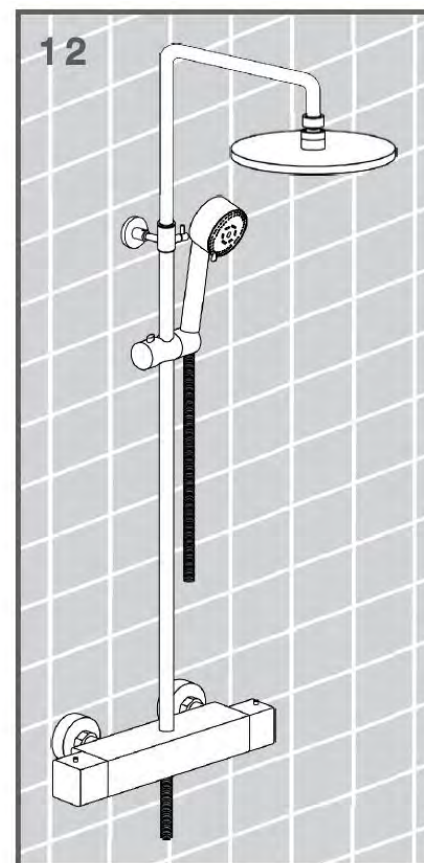
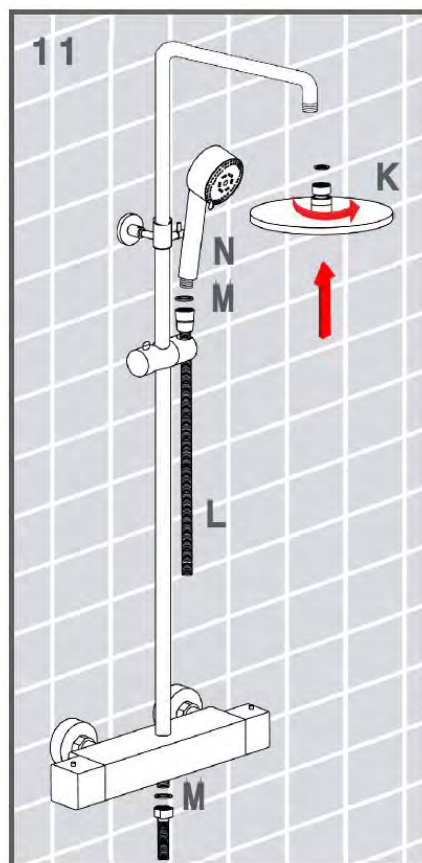
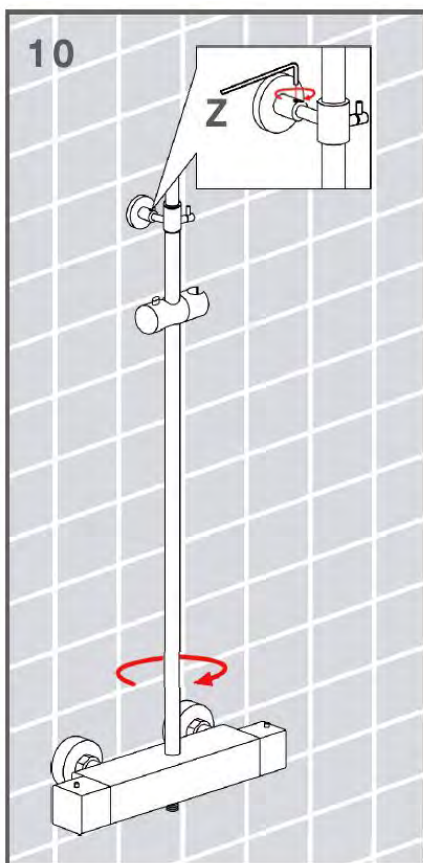
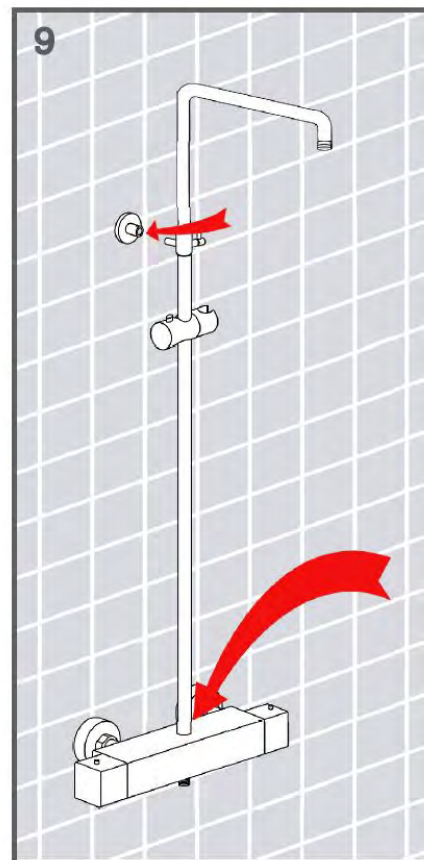
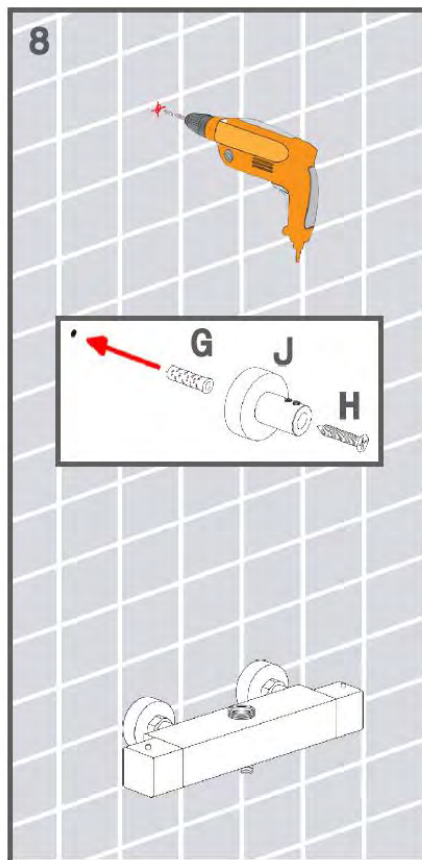
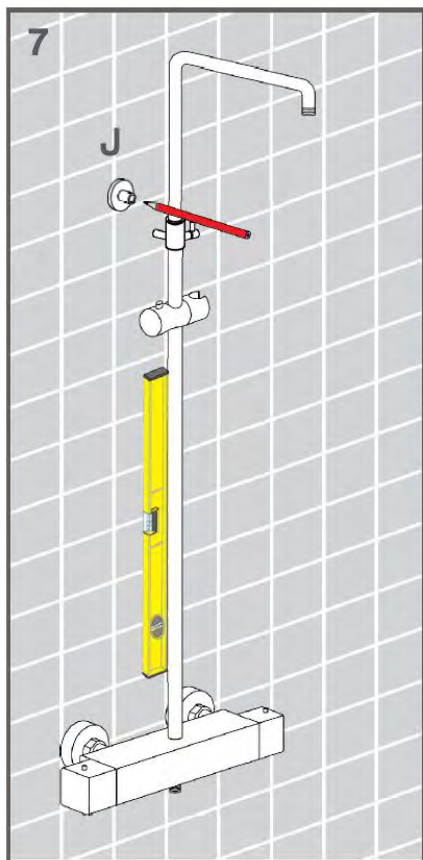

Showed below are the recommended assembly and employ instructions. For any discrepancy between instructions and article features, please refer to the item. We reserve the right to modify the manual.

### Advice on maintenance and use of the product

1. If the water pressure seems to be low or you notice a decrease in the water quantity, please check if the nozzle or the hose are clogged. In this case please disassemble the tap and clean the elements.
2. Please use a soft cloth and clear water to clean the surface of the tap. Don't use abrasive sponge or harsh cleansers in order not to damage or to scratch the chromed surface.
3. Please dry and polish the chromed surface with a soft dry cloth after each usage and cleaning.

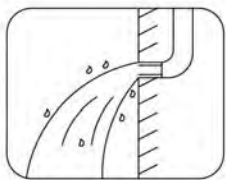

### Are excluded from guarantee:

- All damages:
  - a) Due to the use of the product in a non-domestic and non-private environment;
  - b) Due to accidental causes or negligence of the purchaser;
  - c) Due to provocati da carelessness, improper use or installation, manipulation, changes of the item or its serial number;
  - d) Due to usage, for every part which doesn't show manufacturing defects.
- Reparation costs associated with foreign body or substances.
- The total loss of the item due to the lack of spare parts taken off the market.
- Total or partial loss of the item for damages due to its use, whatever they may be.
- Transportation costs for the repair or the substitution of spare parts.
- Maintenance, regulation, repairs, loss, manipulation, and damages due to improper use or installation.







## Instructions de montage I



Rincer les tuyaux même pour les nouvelles installations.

Dans 90% des cas, saleté et impuretés sont la cause des problèmes dans les robinets.



1

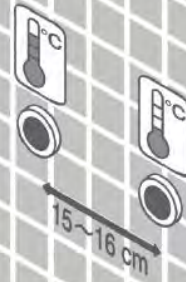

2

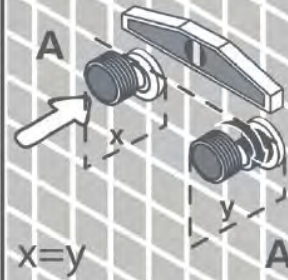

3

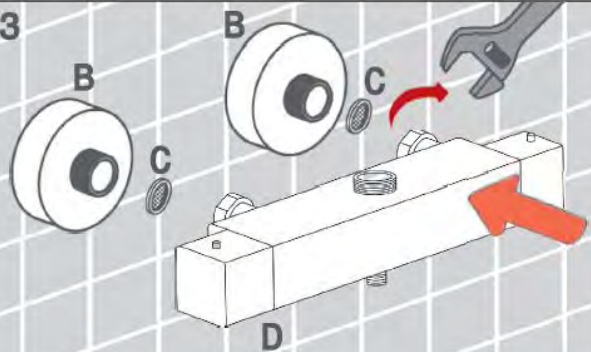

4

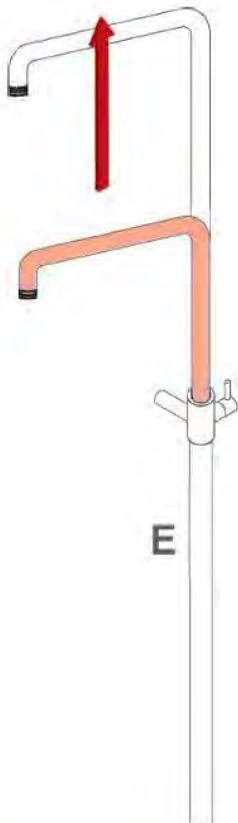

5



6

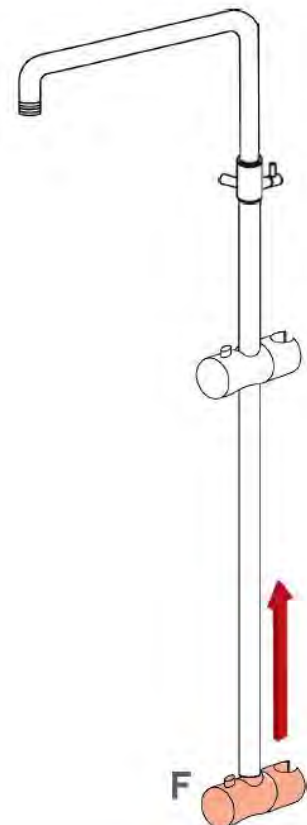

## Instructions de montage II

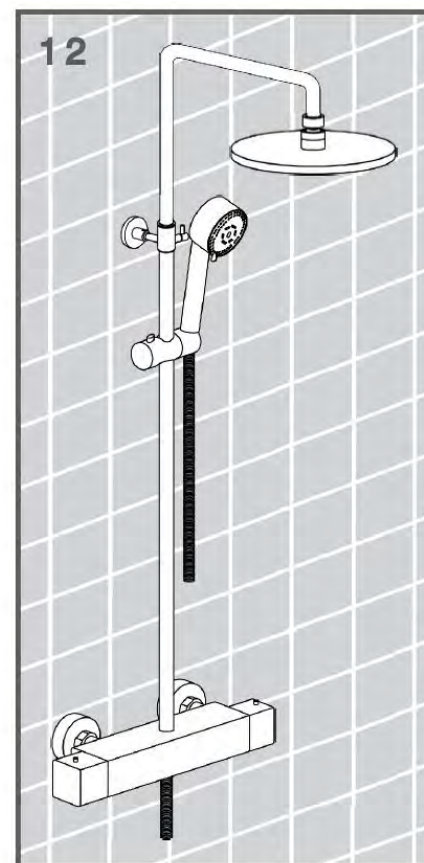
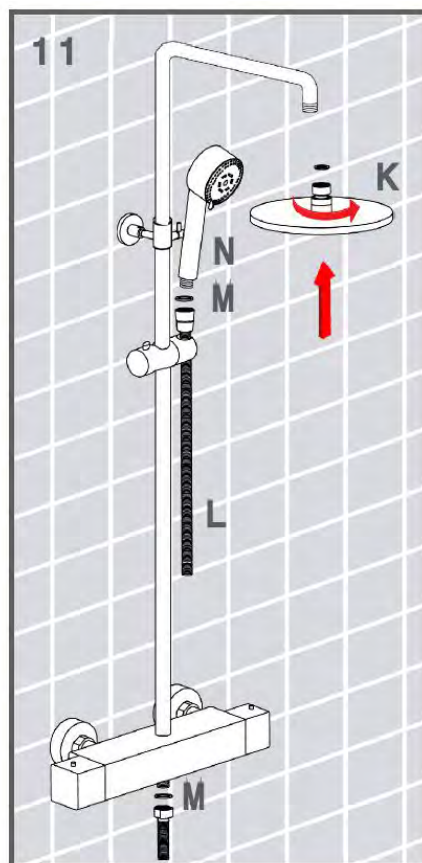
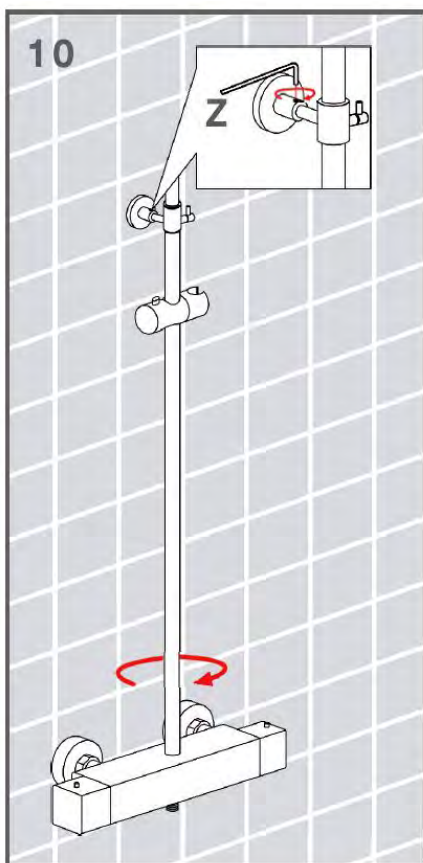
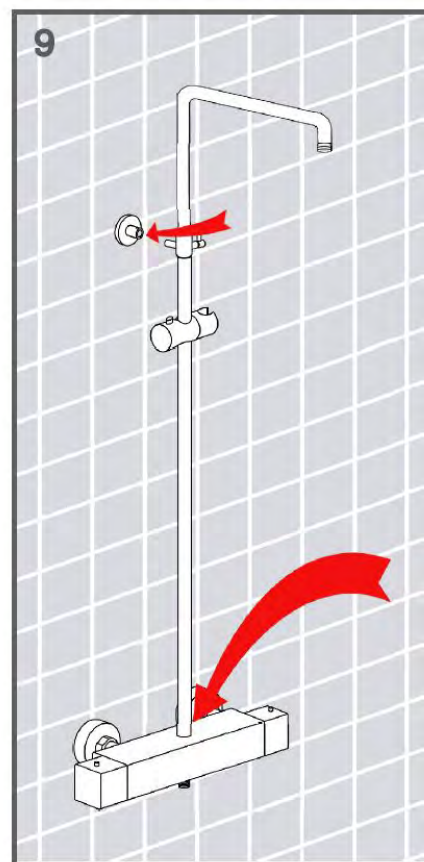
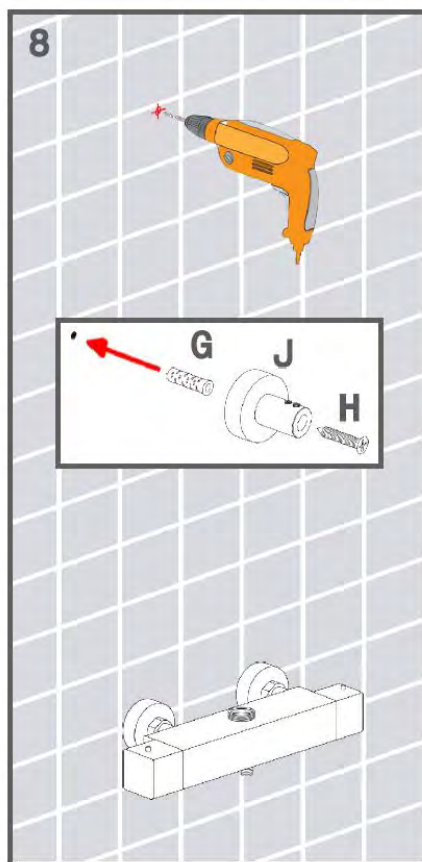
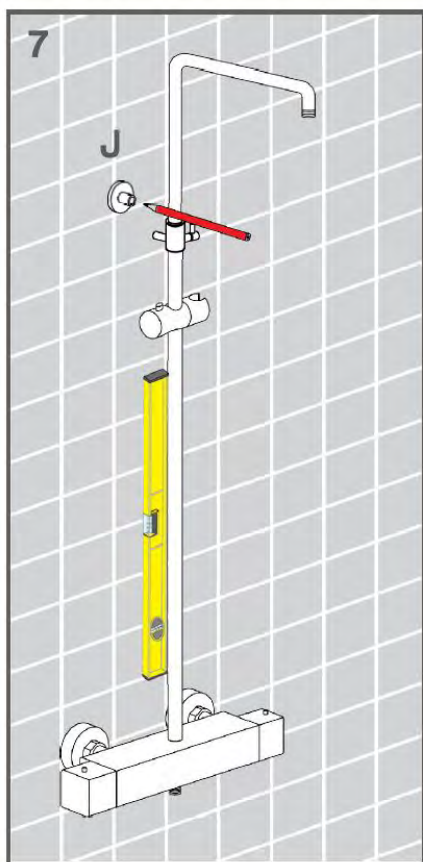

Les présentes instructions de montage ne sont qu'une recommandation. Lors de divergences entre le manuel et le produit réel, ce dernier fera foi. Nous nous réservons le droit de les modifier.

## Conseils d'entretien

1. Si l'eau du robinet circule mal, la buse ou le flexible du mélangeur peuvent être encrassés par du calcaire ou des impuretés. Dans ce cas, dévissez et nettoyez.
2. Pour nettoyer la robinetterie, utilisez un chiffon doux ou une éponge avec uniquement de l'eau froide. Ne jamais utiliser des produits détergents abrasifs, des substances corrosives ou trop agressifs qui pourraient endommager et rayer votre robinet.
3. Appliquez le produit sur un chiffon humide, enlevez les salissures, rincez abondamment avec de l'eau propre et froide puis séchez avec un tissu ou un chiffon doux.

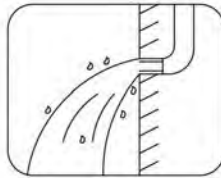

## Sont exclus de la garantie:

- tous les dommages qui sont dus à
  - a) une utilisation qui ne se limite pas à un usage privé
  - b) une négligence délibérée,
  - c) une détérioration causée par une mauvaise installation ou une utilisation non conforme, une mauvaise utilisation.
  - d) à une usure et une dégradation normale
  - e) un montage incorrect.
- Coûts de réparation liés à des dommages causés par des corps étrangers ou des substances étrangères .
- Une perte totale du produit en raison des pièces de rechange qui ne sont plus disponibles.
- Une indemnité de perte d'usage du produit ou des dommages Directs, indirects ou consécutifs de quelque nature ce soit.
- Frais encourus pour la réparation et/ou le remplacement des pièces de rechange.
- Les coûts liés à la maintenance, réglage, réparation, perte, modification, transformation, dégâts, y compris les frais de réparation des dommages résultant d'un mauvais montage, utilisation, maintenance.

RUBINETTO NT6185C

**BERNSTEIN**  
Vivere con Stile



**ISTRUZIONI DI MONTAGGIO**

GIUGNO 2017



# Rubinetto NT6185C

Grazie per il Suo acquisto.

Si prega di leggere attentamente il manuale di istruzioni prima dell'installazione e dell'utilizzo del prodotto.

## Contenuto della consegna

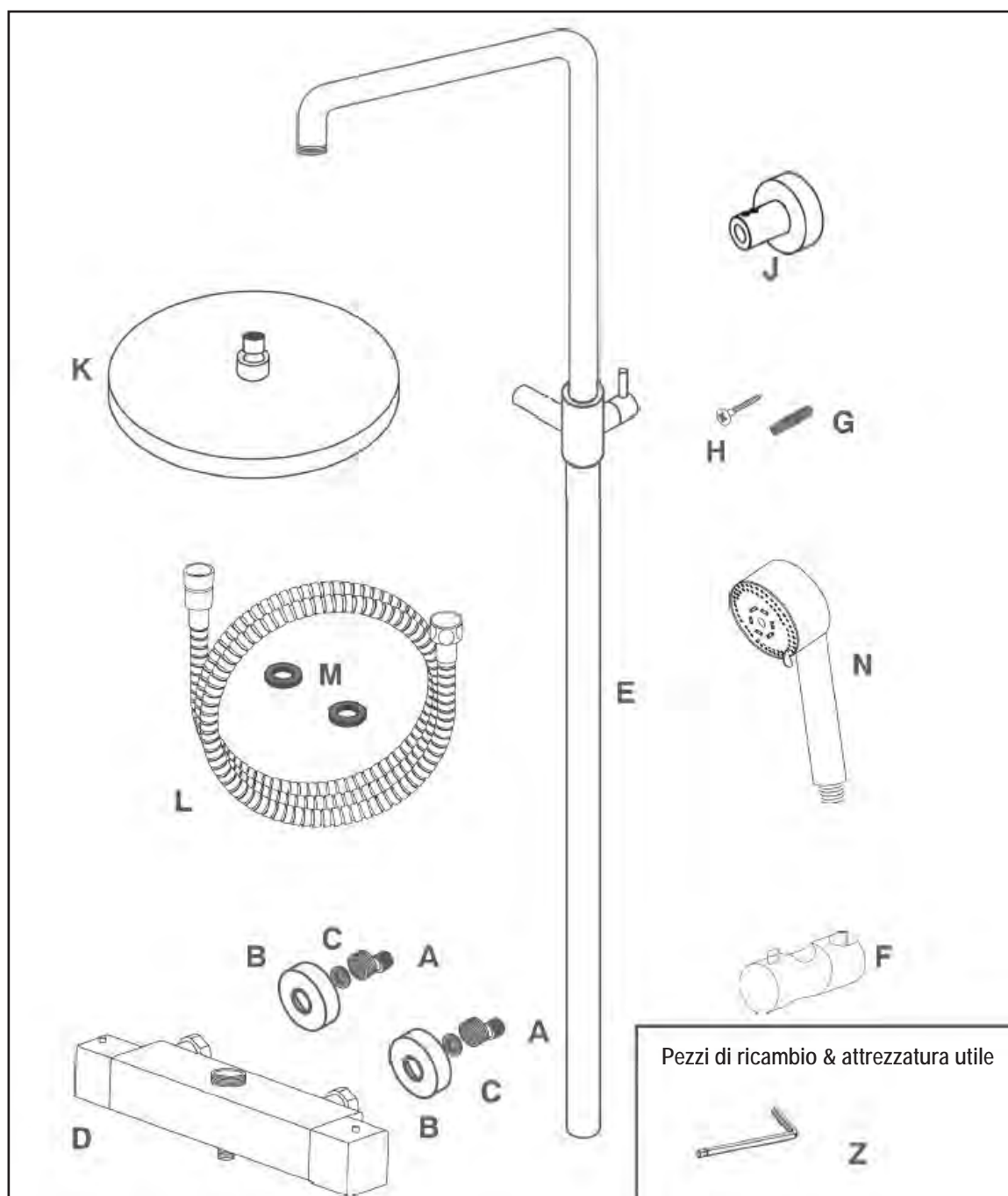

38°C standard

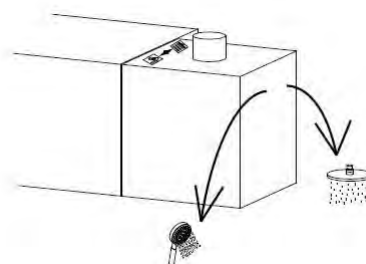
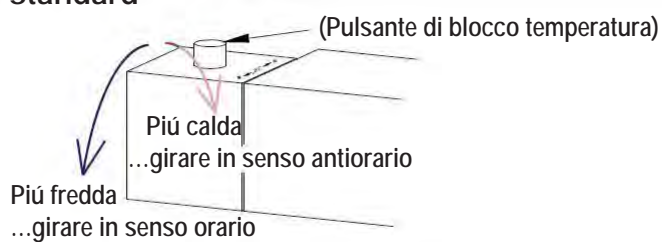

## Istruzioni di montaggio I



Sciacquare accuratamente le tubature anche nel caso di impianti nuovi.

Nek 90 % die casi sporco e contaminazione sono la causa die problemi die rubinetti.

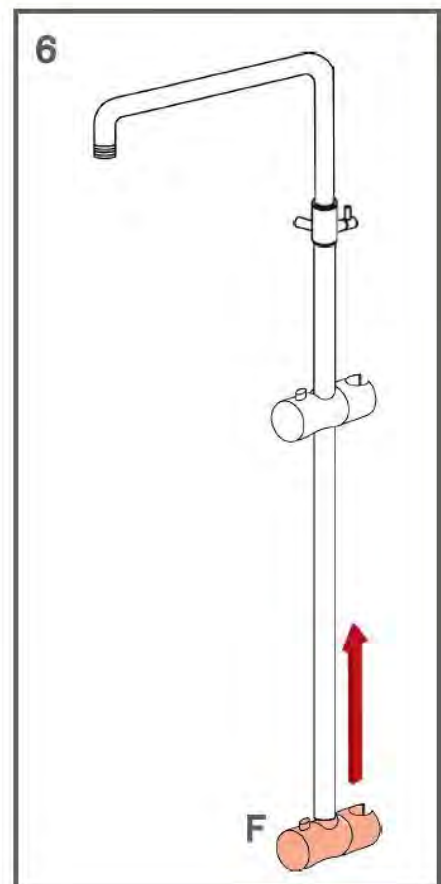
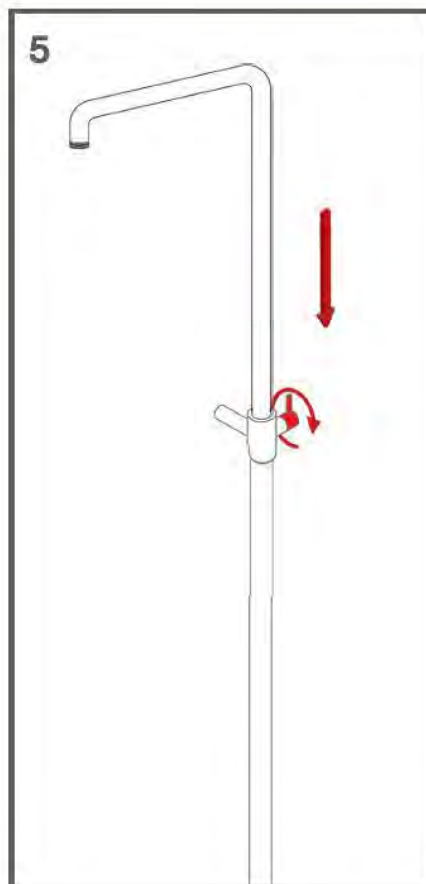
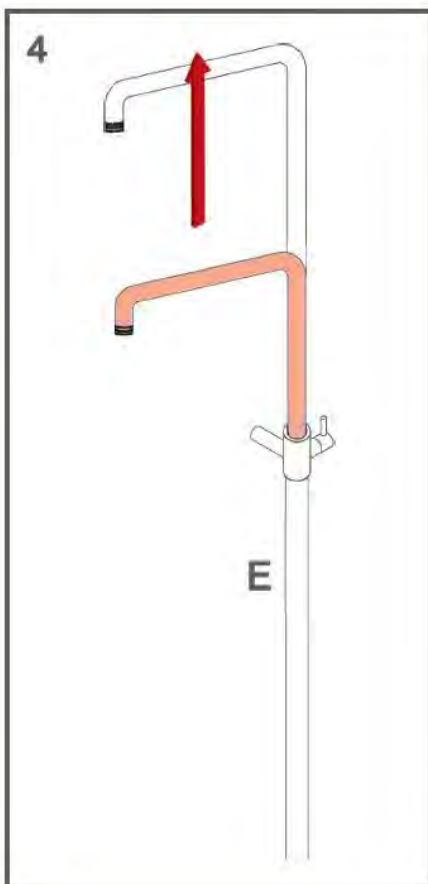
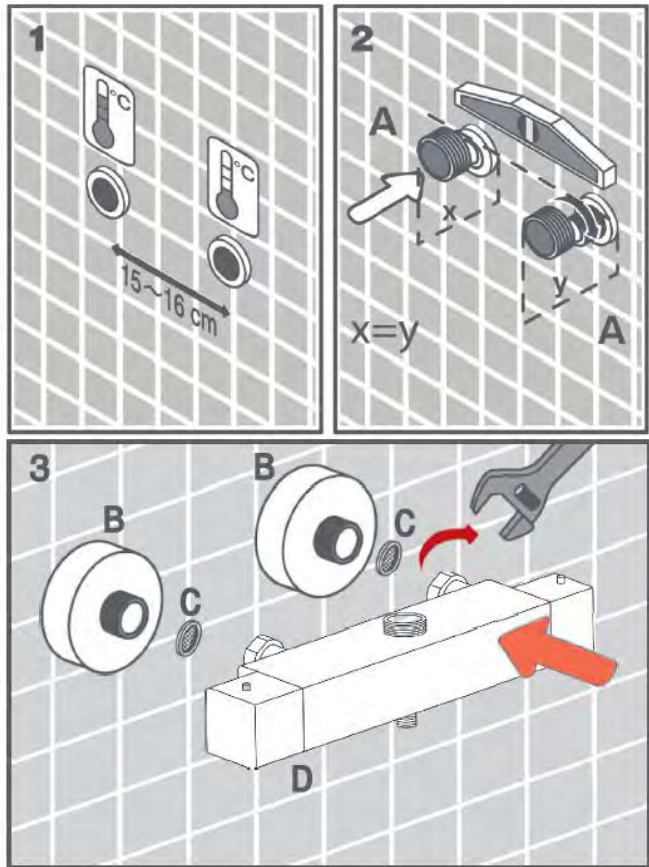

## Istruzioni di montaggio II

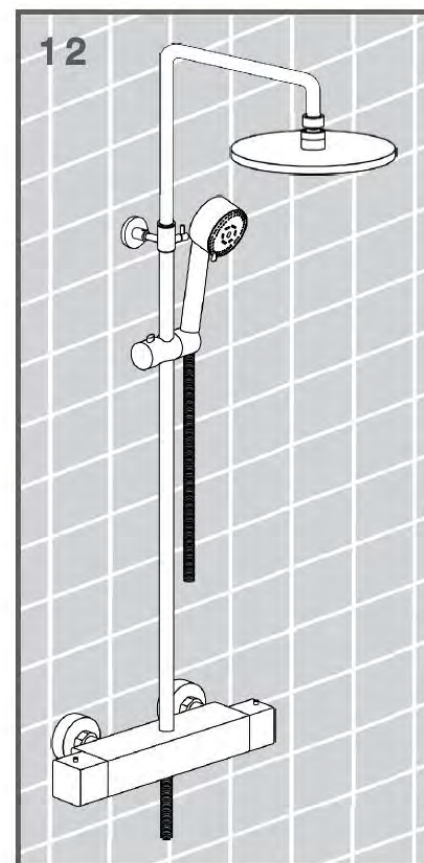
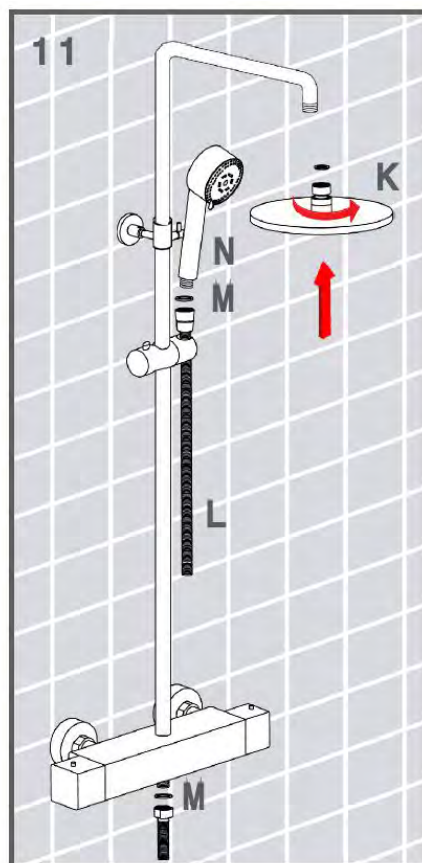
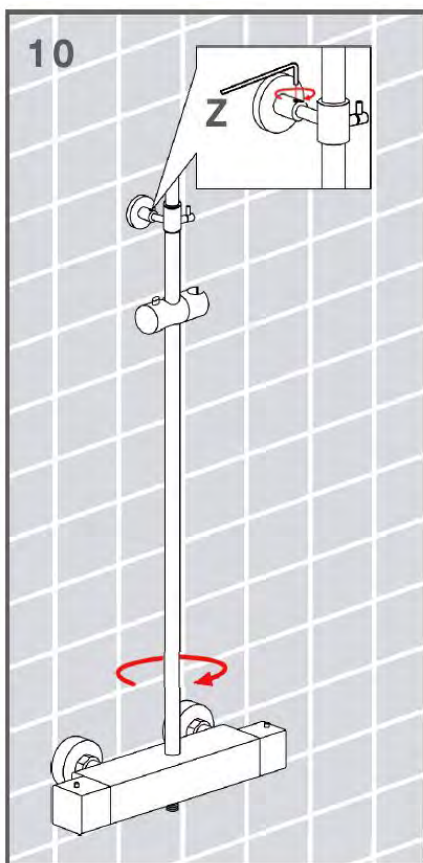
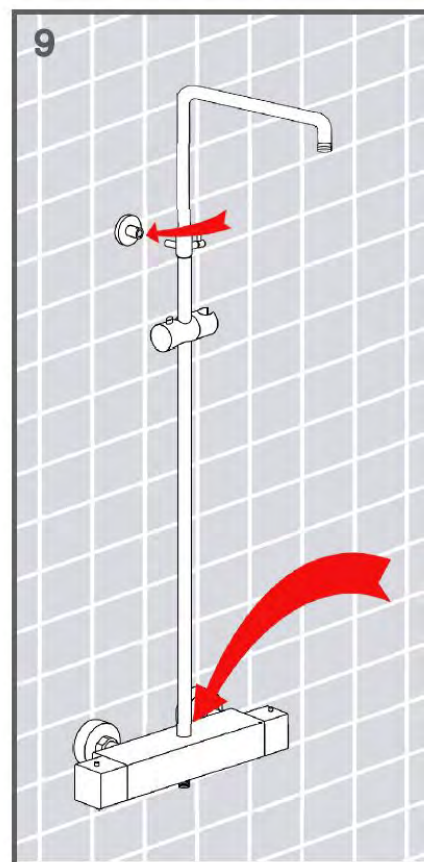
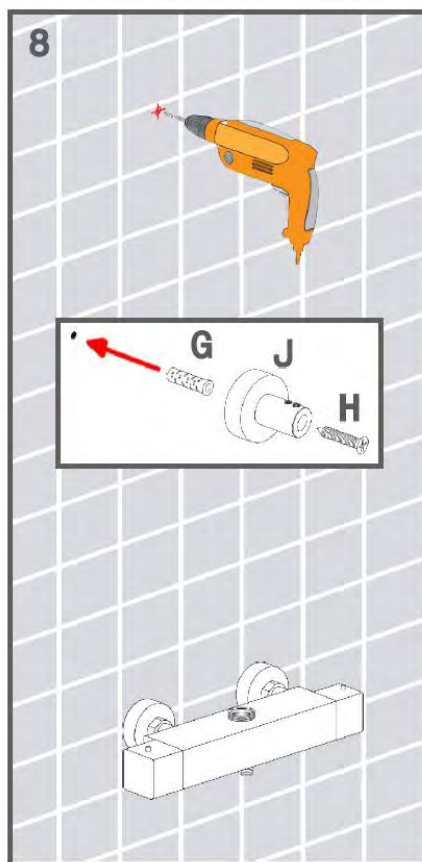
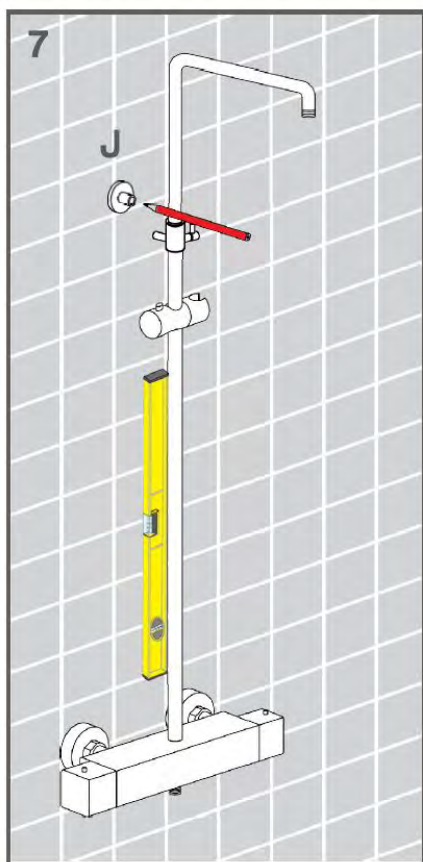



Di seguito troverete elencate le istruzioni di montaggio e utilizzo raccomandate. Se sussistessero delle discrepanze tra le istruzioni e le caratteristiche del prodotto, fare riferimento a queste ultime. Ci riserviamo il diritto di effettuare delle modifiche.

## Consigli per la manutenzione

1. Se la pressione dell'acqua sembra troppo bassa o si verifica una diminuzione, controllare che l'ugello o il flessibile non siano intasati. In questo caso smontare e pulire gli elementi.
2. Si prega di utilizzare un panno soffice o acqua pulita per detergere la superficie del rubinetto. Non utilizzare spugne abrasive o detergenti aggressivi per non corrodere o graffiare la superficie cromata.
3. Asciugare e lucidare la superficie cromata dopo ogni utilizzo e ogni pulizia, con un panno morbido e asciutto.

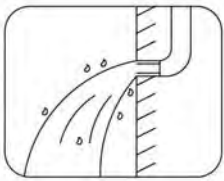

## Sono esclusi dalla garanzia:

- Tutti i danni:
  - a) conseguenti all'utilizzo non privato e domestico del miscelatore
  - b) dovuti a cause accidentali o a negligenza dell'acquirente
  - c) provocati da incuria, uso o installazione non conformi alle istruzioni fornite, manomissione, modifiche del prodotto o del numero di matricola
  - d) da usura in seguito all'utilizzo, le batterie quando fornite in dotazione, cavi e cordoni di connessione, connettori, parti esterne e supporti in plastica, che non presentino difetti di fabbricazione
- I costi di riparazione legati a danni causati da corpi o sostanze estranei.
- La perdita totale del prodotto dovuta alla mancanza di pezzi di ricambio non più in commercio.
- Indennità per perdita parziale o totale del prodotto dovuta a danni consecutivi al suo utilizzo qualunque essi siano.
- Costi di trasporto e di spostamento per la riparazione o la sostituzione dei pezzi di ricambio.
- Costi di manutenzione, regolazione, riparazione, perdita, modifica, trasformazione, danni causati da un'installazione o un uso improprio del prodotto.